

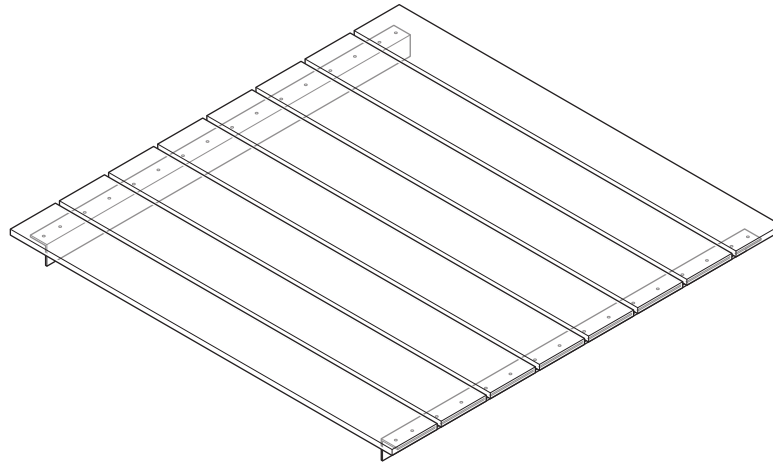

Tommy Docks  
 8608 Progress Way, Weston, WI 54476  
 Phone: 715-842-3804  
 Toll Free: 866-675-1880  
 Fax: 715-842-3420

# Drop-In Panel Kit for Composite Boards

## Assembly Instructions



### Components

**Composite Boards**  
 (Qty 8)

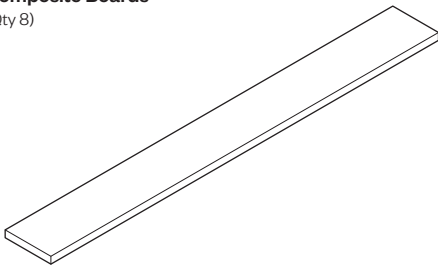

**Aluminum Brackets**  
 (Qty 2)

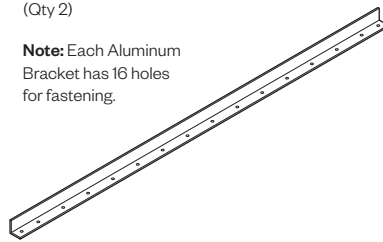

**Note:** Each Aluminum Bracket has 16 holes for fastening.

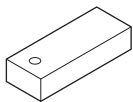

**Drop-In Latch**  
 (Qty 2)

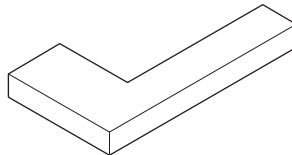

**Bracket Aligner**  
 (Qty 2)

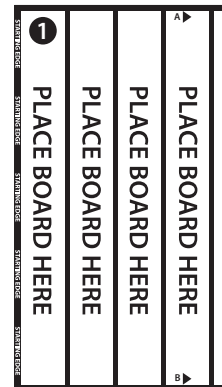

**Template 1**  
 (Qty 1)



**Template 2**  
 (Qty 1)

### Tools



Tape



Power Drill

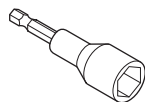

Provided Driver Bit

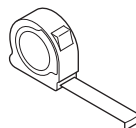

Measuring Tape

### Hardware



**3/4" (#12) Fastener-A**  
 (full threaded)  
 (Qty 30)

**Note:** 15 per side.



**1-1/4" (#12) Fastener-B**  
 (full threaded)  
 (Qty 2)

**Note:** 1 for each side (Use in hole #8 on each aluminum rail with Drop-In Latch (block))

1

Place Template 2 on top of Template 1.

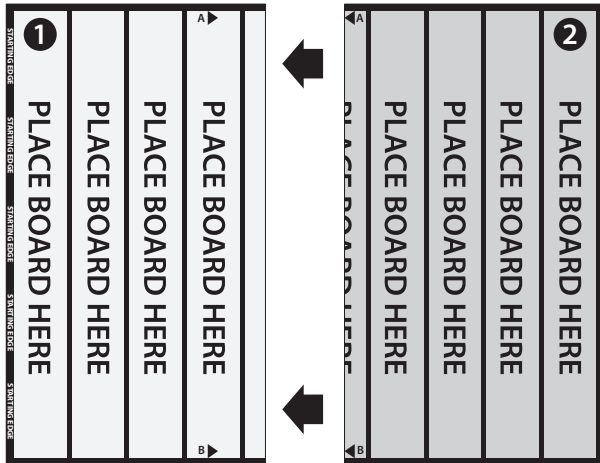

2

Align "A" Arrows and align "B" Arrows. Once arrows are aligned, tape both templates together.

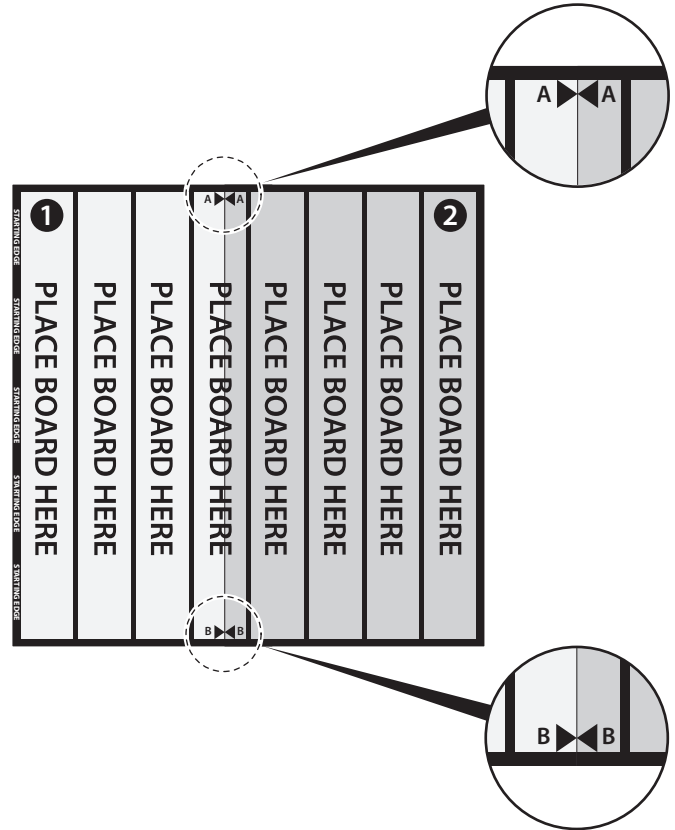

3

Begin by laying out the provided 48" x 48" Paper Template on a flat surface such as a floor or a sheet of plywood. Place Composite Boards into indicated "PLACE BOARD HERE" area making sure to keep wood grain finish facedown.

**IMPORTANT:** When aligning Composite Board, make sure you align it along the edge of template labeled "STARTING EDGE".

**NOTE:** Very important to make sure the wood grain texture of the board is facedown during this step. This will be the finished dock top.

4

Continue placing Composite Boards onto 48" x 48" Paper Template making sure to keep wood grain finish facedown.

**NOTE:** Very important to make sure the boards are evenly spaced so they align with the black lines on the template.

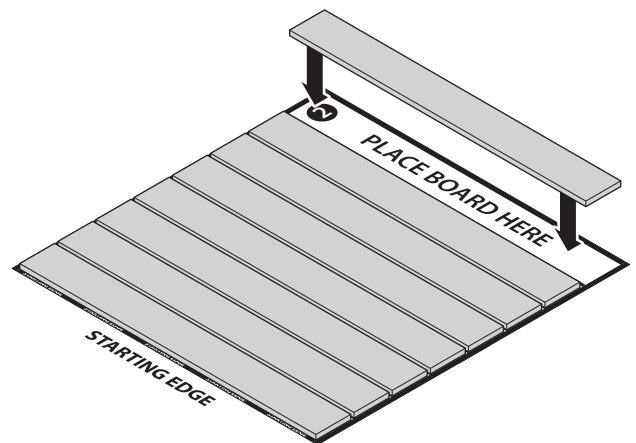
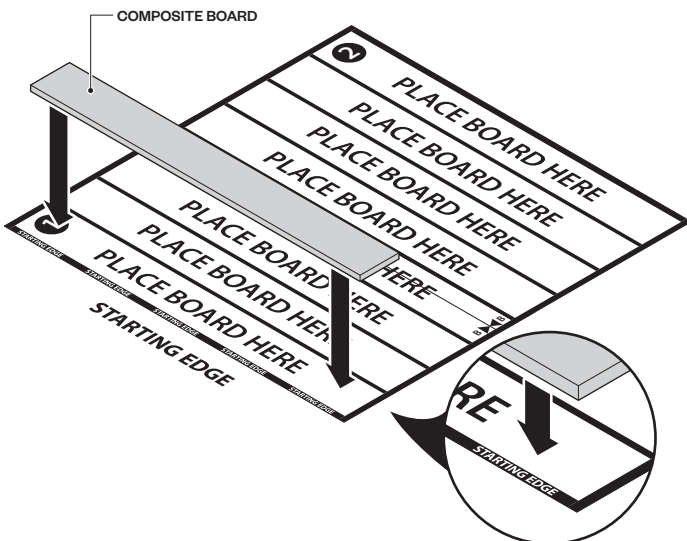

**5** Place Aluminum Brackets onto boards.

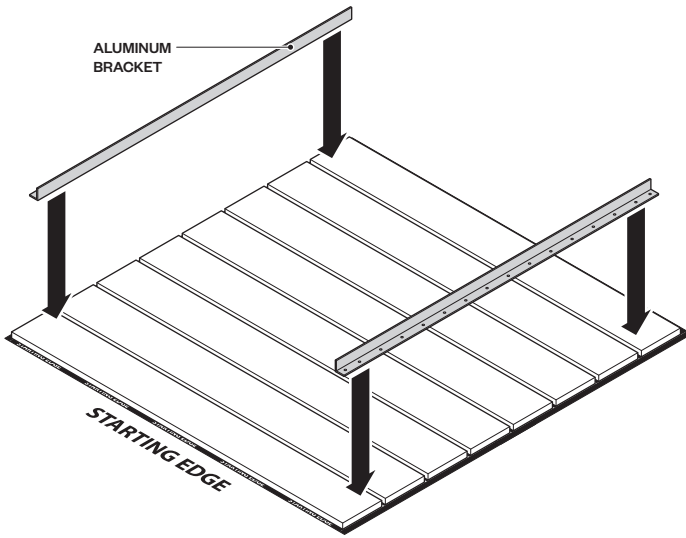

**6** In order to align Aluminum Brackets properly, position the two (2) provided Bracket Aligners next to each Aluminum Bracket toward the "STARTING EDGE" end. Make sure Bracket Aligners are flush with all four (4) corners of boards. Flip Bracket Aligner and run down the edge to maintain distance of Aluminum Bracket from edge of boards.

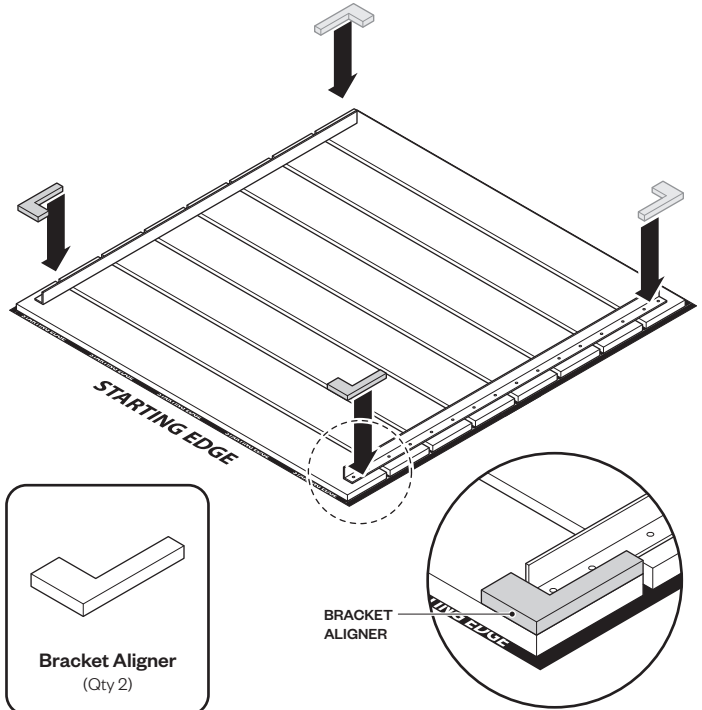

**7** Using the Provided Driver Bit, secure Aluminum Brackets to End Boards using two (2) 3/4" (#12) Fastener-A per corner.

**DO NOT OVER TORQUE**

Slowly screw in fastener heads no more than one full turn so head makes contact with aluminum.

**Over torquing screws will cause stripping.**

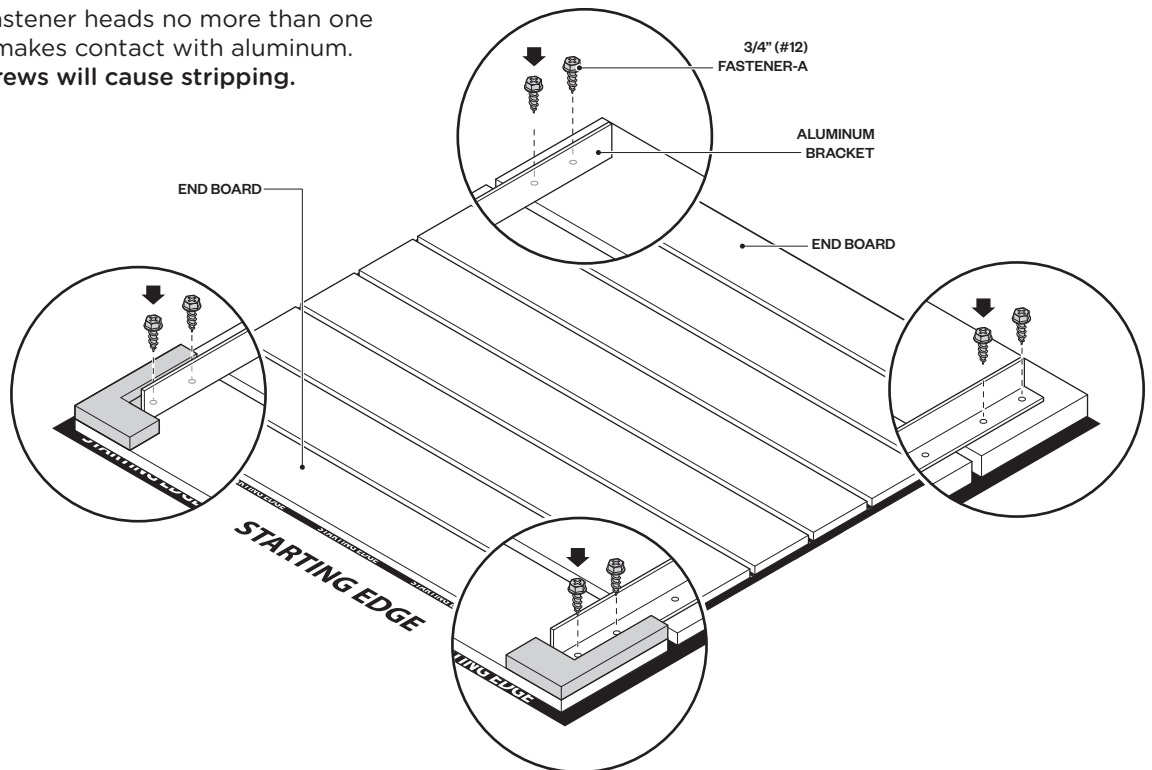

**3/4" (#12)  
Fastener-A  
(full threaded)  
(Qty 8)**

8

Measure Diagonal at the corners to check for square.

**NOTE:** If the diagonals measure the same length, you know that the drop-in panel is square.

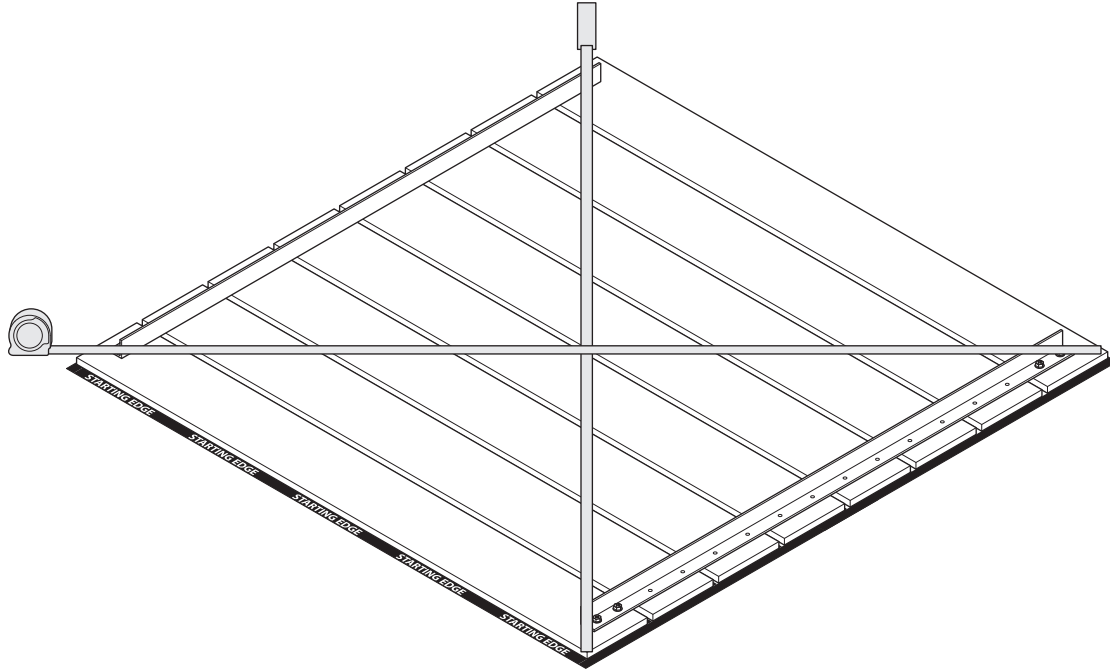

9

Install remaining Fastener-A (11 per side), making sure not to install a screw into the 8th hole on each Aluminum Bracket (9a) and install Drop-In Latch using one (1) Fastener-B per Latch (9b).

Locate 8th hole on each side of Aluminum Bracket (9a) from the "Starting Edge" and install Drop-In Latch using one (1) Fastener-B per Latch (9b).

**NOTE:** Do not tighten all the way down tight. This latch needs to be able to turn to be used as a latch to the aluminum frame (9c).

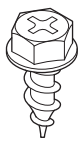
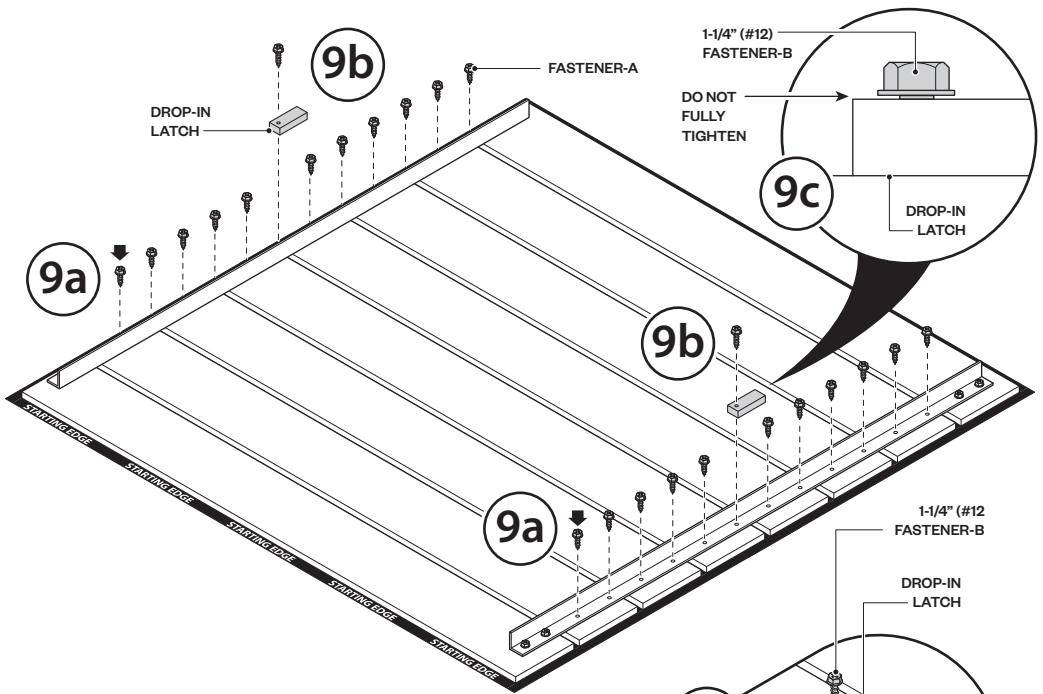

**3/4" (#12)  
Fastener-A**  
(full threaded)  
(Qty 22)

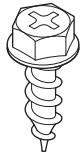

**1-1/4" (#12)  
Fastener-B**  
(full threaded)  
(Qty 2)

**Note:** 1 for each side (Use in hole #8 on each aluminum rail with Drop-In Latch (block)

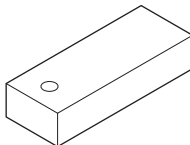

**Drop-In Latch**  
(Qty 2)

