

ASSEMBLY INSTRUCTIONS

ITEM NO.: FB5011JHC-1/2/3/4

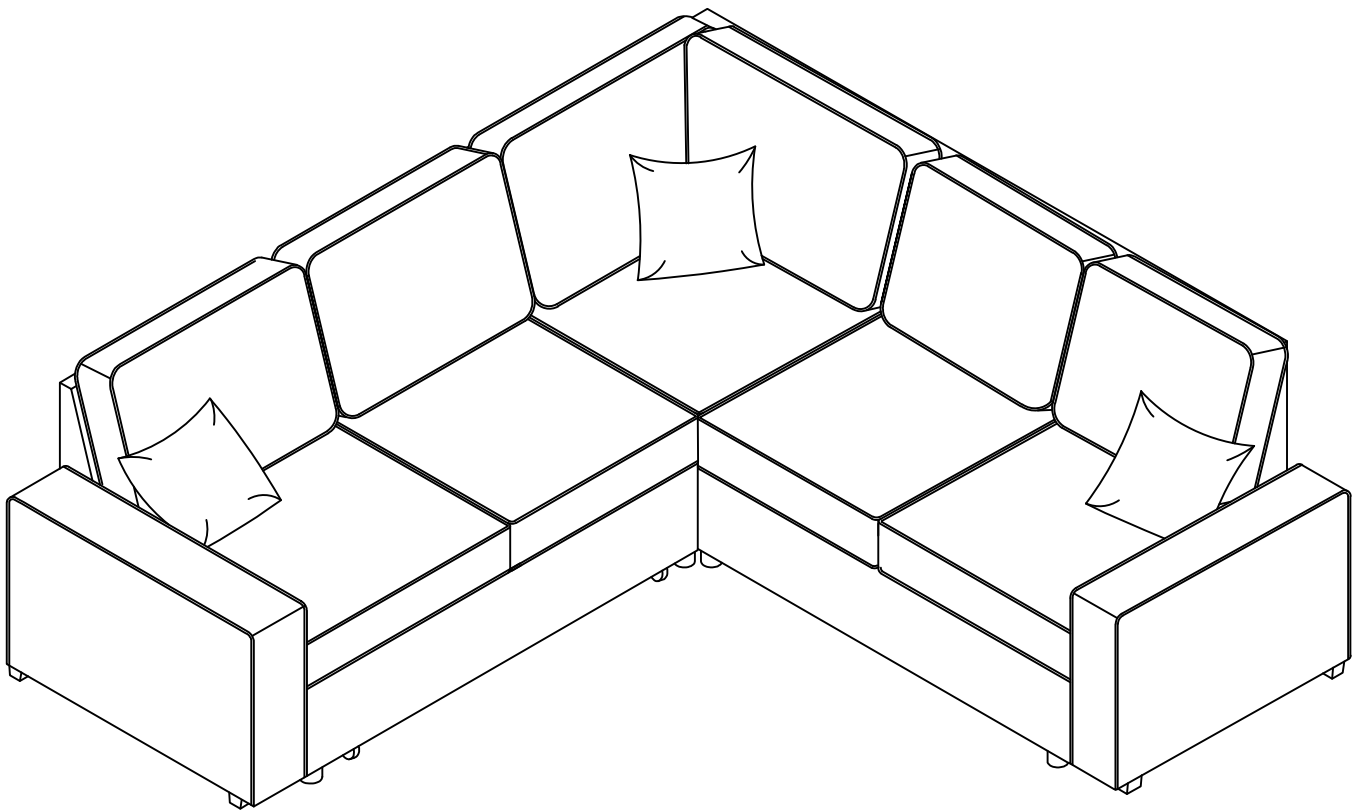







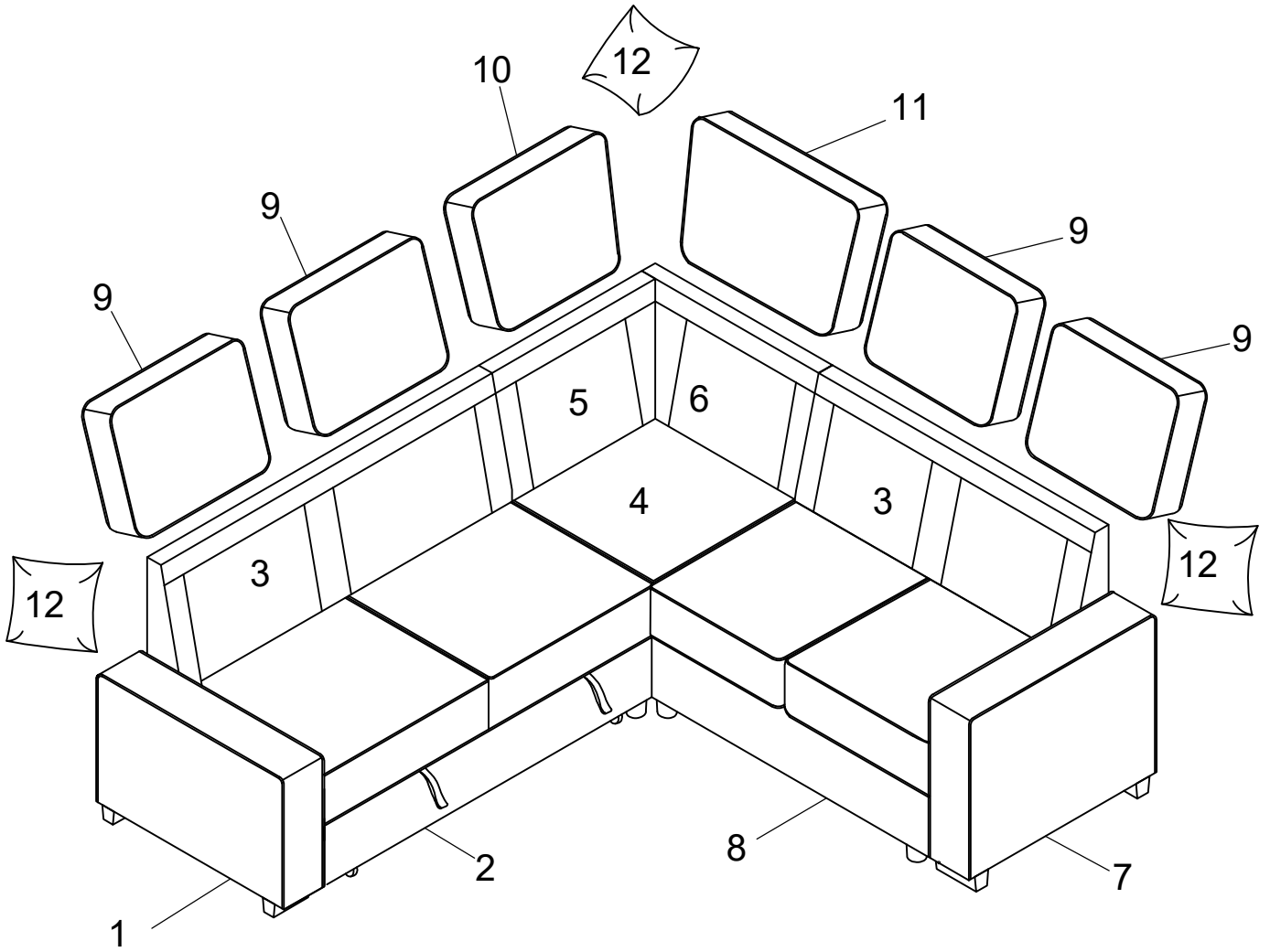



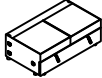

ASSEMBLY TIPS:

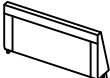
1. Remove hardware from box and sort by size.
2. Please check to see that all hardware and parts are present prior to start of assembly.
3. Please follow attached instructions in the same sequence as numbered to assure fast & easy assembly.

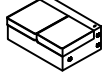

Exploded View







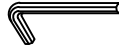







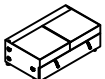



PARTS LIST

NO.	DIAGRAM	PART NAME	Q'Ty
1		Left Arm	1
2		Loveseat Body (L)	1
3		Loveseat Back Frame	2
4		Corner Frame	1
5		Corner Left Backrest	1
6		Corner Right Backrest	1
7		Right Arm	1
8		Loveseat Body (R)	1
9		Back Cushion	4
10		Corner Back Cushion (L)	1
11		Corner Back Cushion (R)	1
12		Pillows	3
13		Legs	8
14		Square Leg	4

HARDWARE LIST

NO.	DIAGRAM	PART NAME	Q'Ty
A		Bolt Ø5/16" x 2"	8
B		Allen Key 4mm	1
C		Roller	2
D		Screw #8x20mm	8

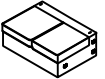
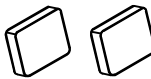
FB5011JHC is packed in 2 cases

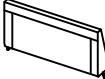
Carton	Disignation	Part		Hardware
FB5011JHC-1	Left Arm	#1		
	Right Arm	#7		
FB5011JHC-2	Loveseat Body (L)	#2		 A x 8pcs
	Back Cushion (2pcs)	#9		 B x 1pc
	Legs (8pcs)	#13		 C x 2pcs
	Square Leg (4pcs)	#14		 D x 8pcs
FB5011JHC-3	Corner Frame	#4		
	Pillows (3pcs)	#12		
	Corner Left Backrest	#5		
	Corner Back Cushion (L)	#11		
	Corner Back Cushion (R)	#10		
FB5011JHC-4	Loveseat Body (R)	#8		
	Back Cushion (2pcs)	#9		
	Loveseat Back Frame (2pcs)	#3		
	Corner Right Backrest	#6		

STEP 1

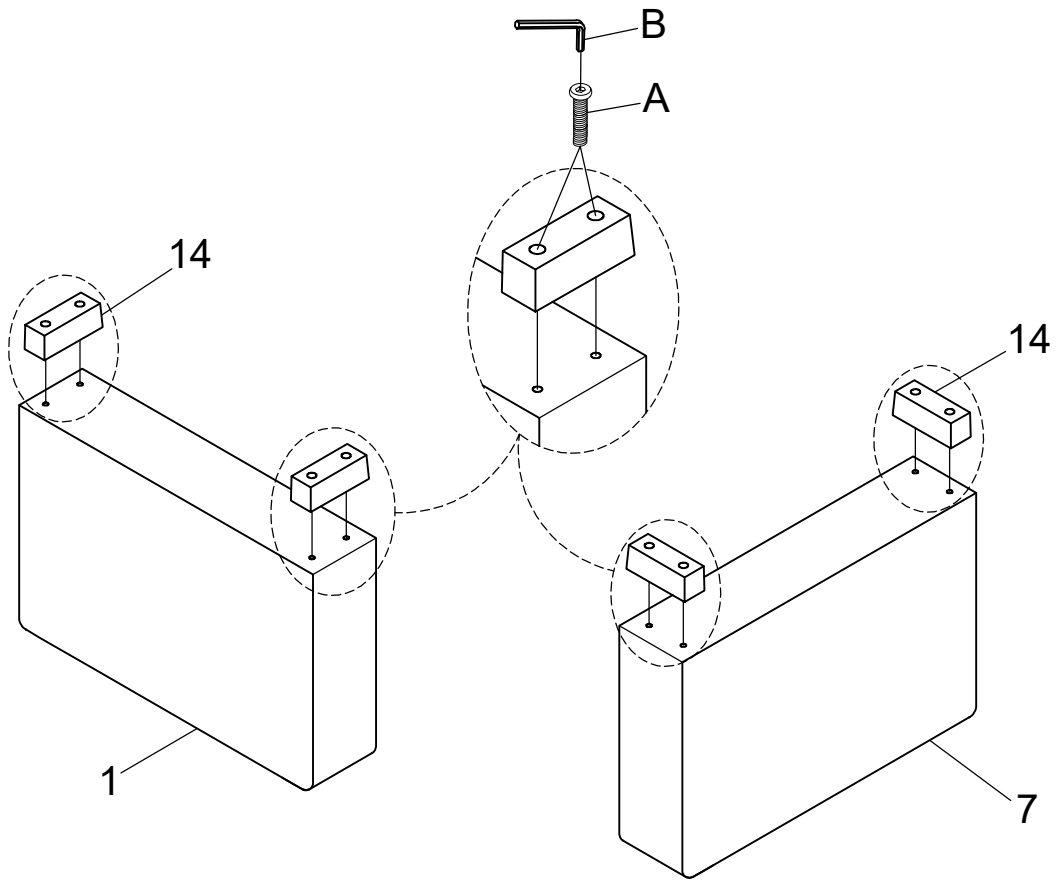

STEP 2

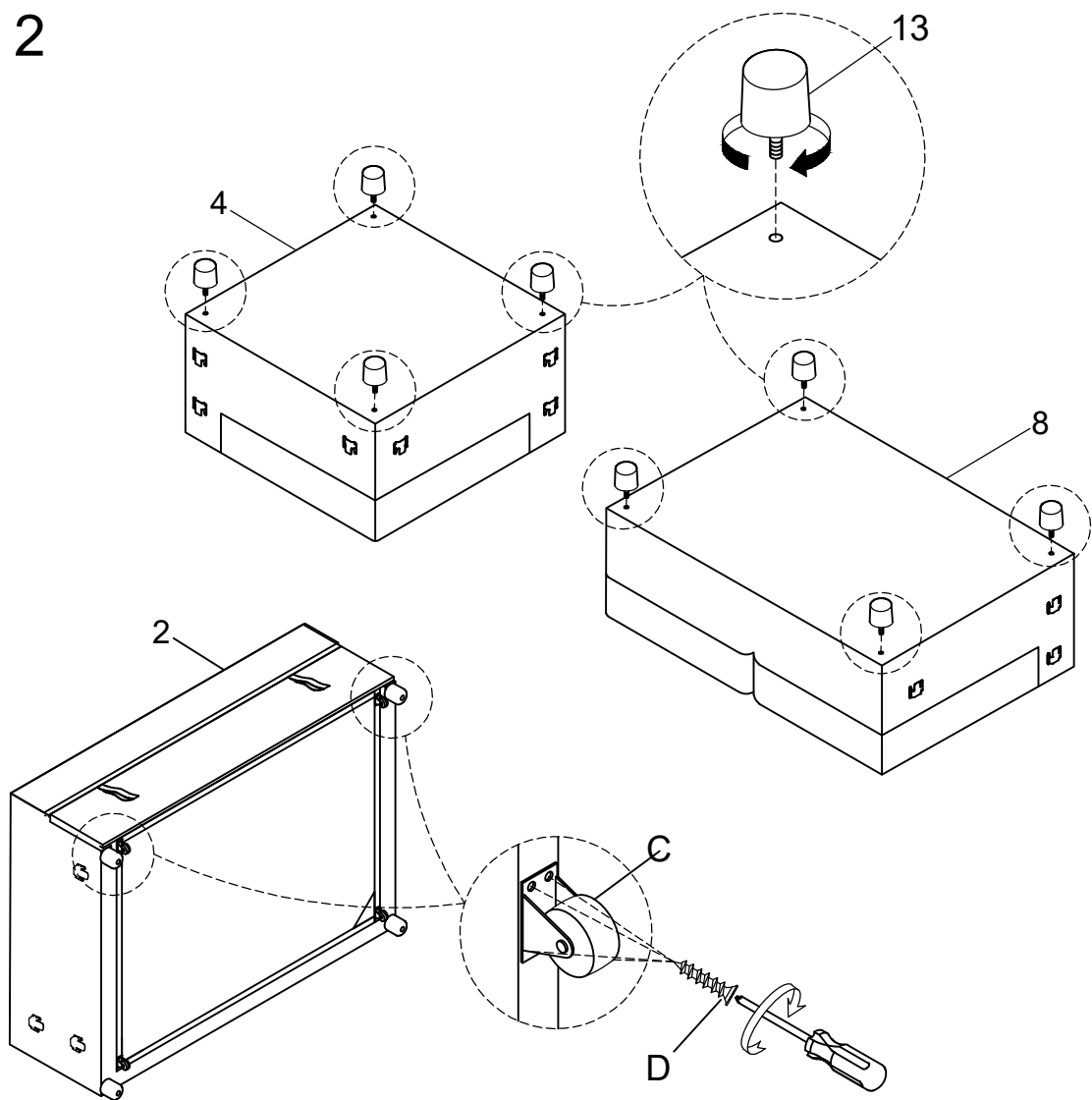

STEP 3

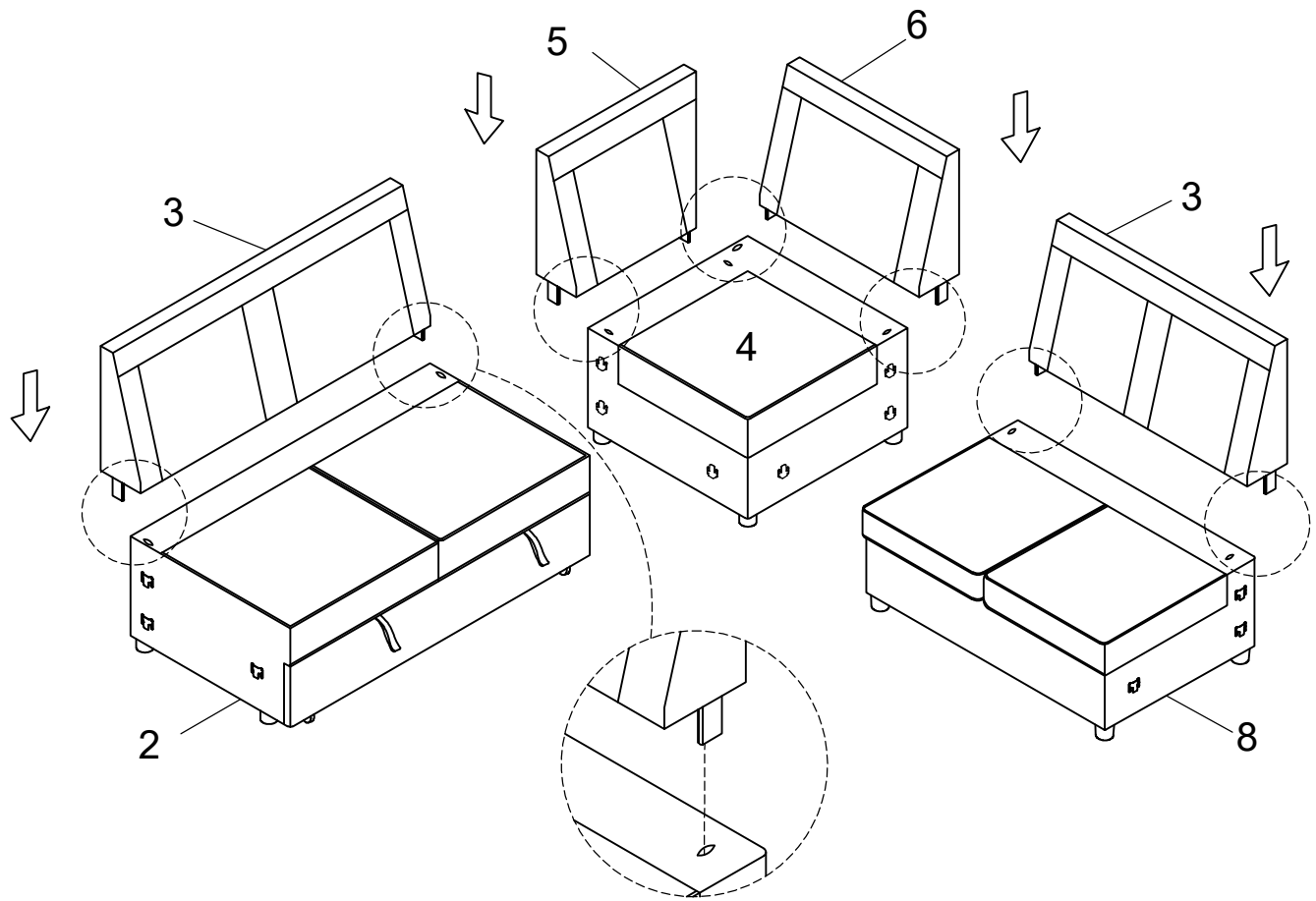

STEP 4

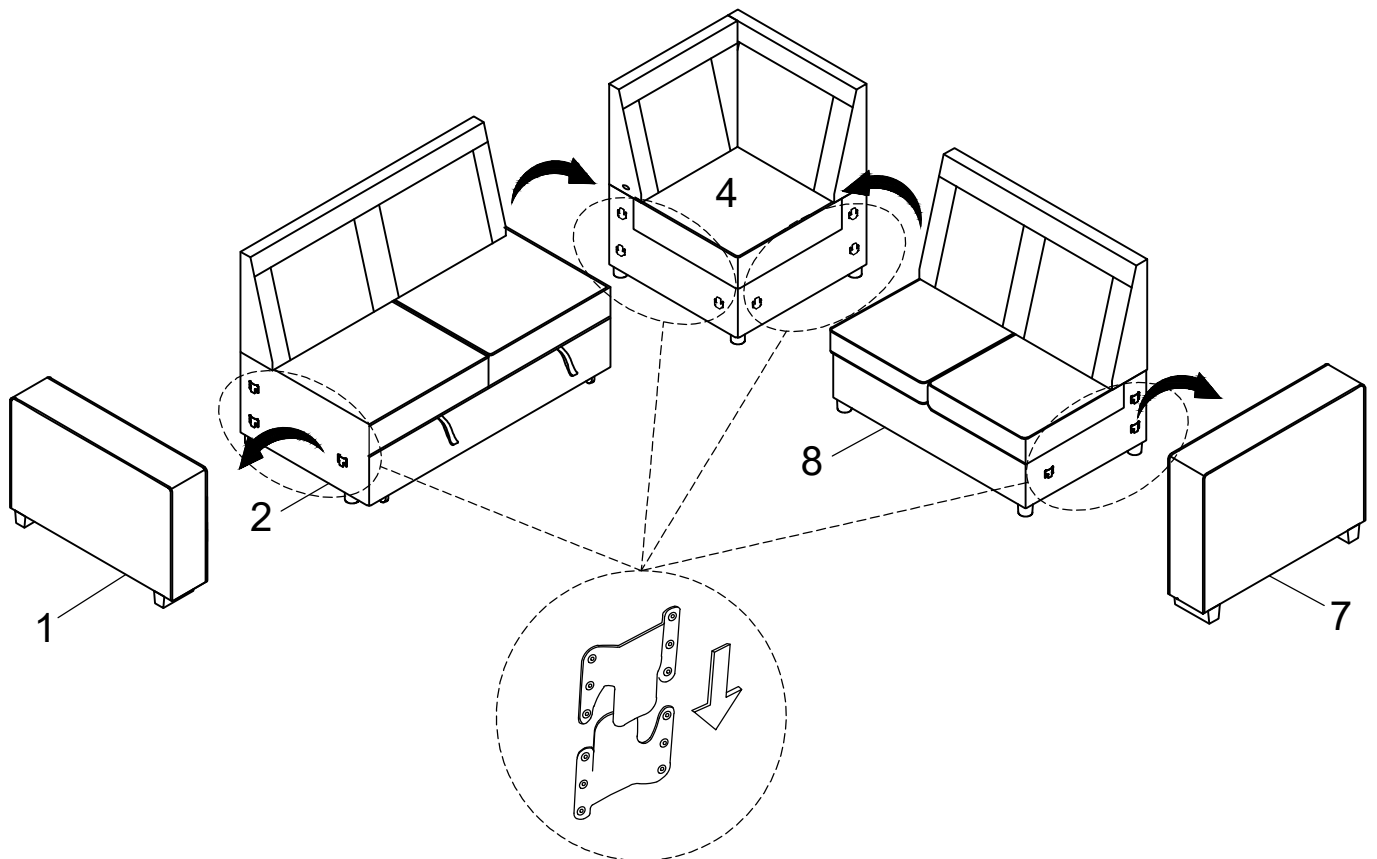

STEP 5

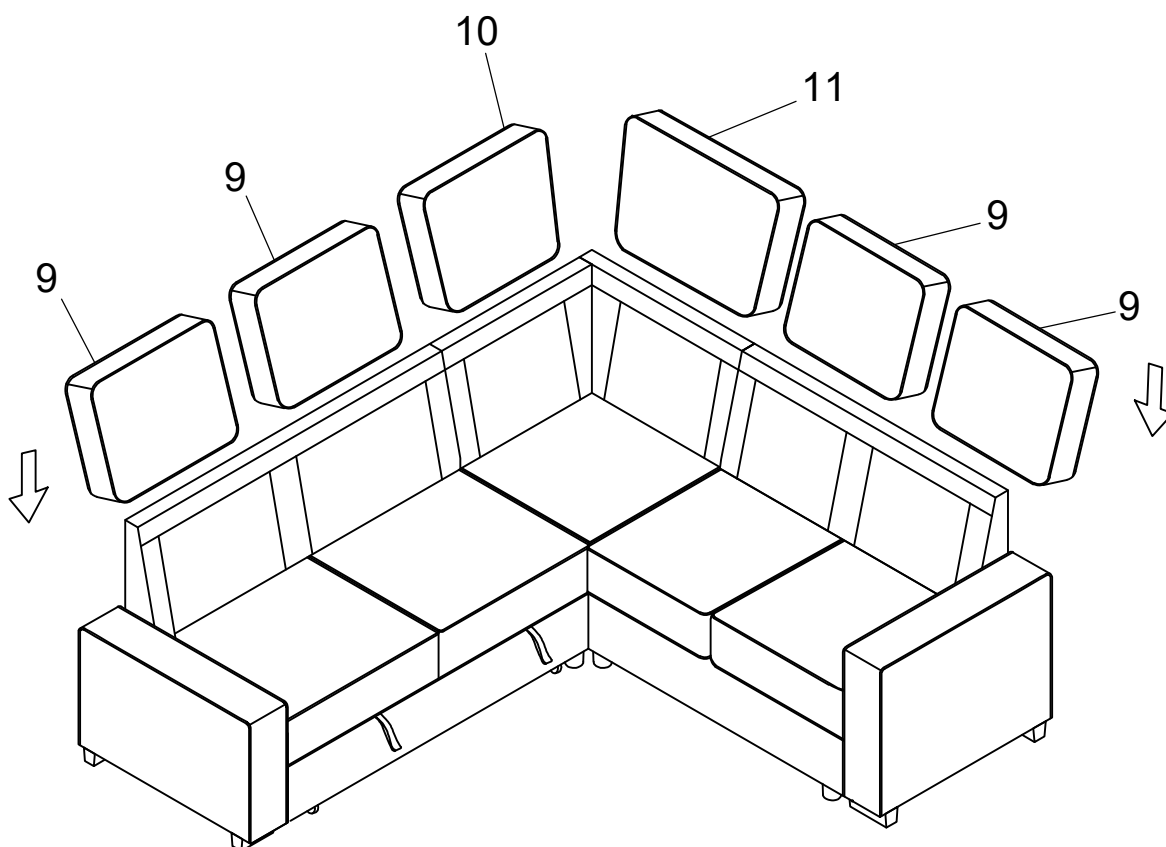

STEP 6

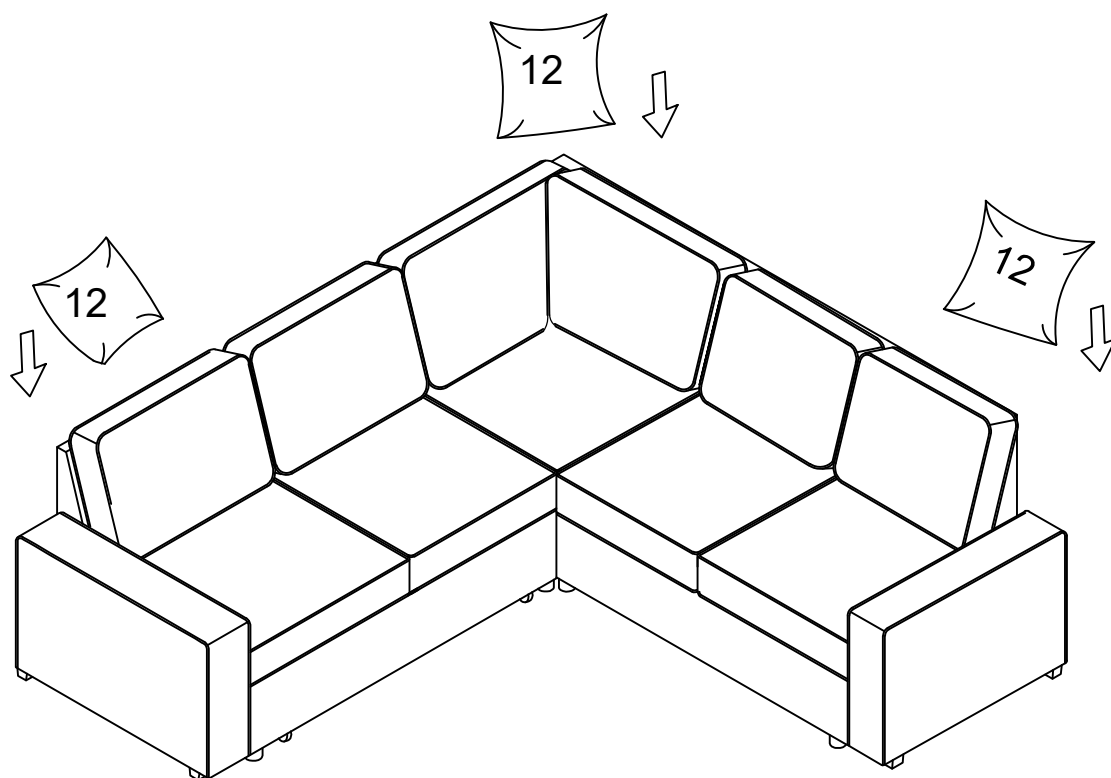

OPTION 1:

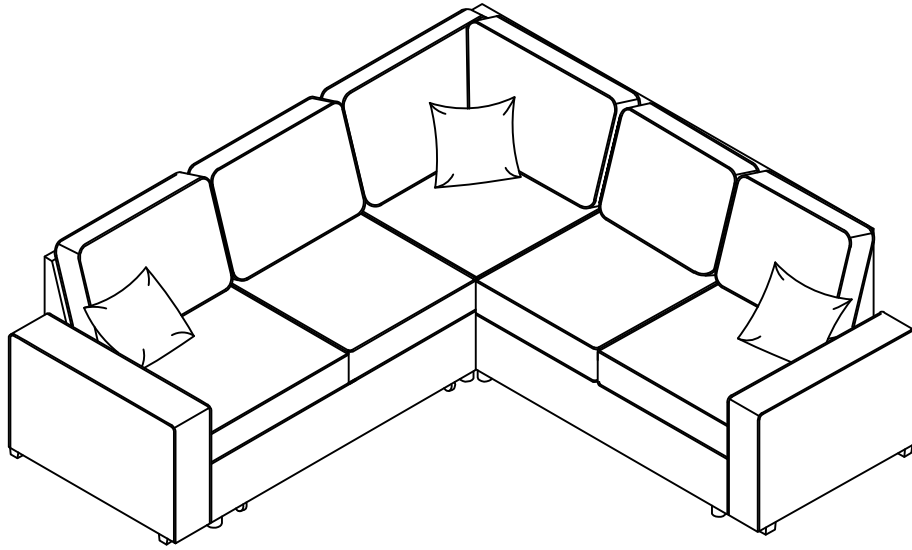

COMPLETED :

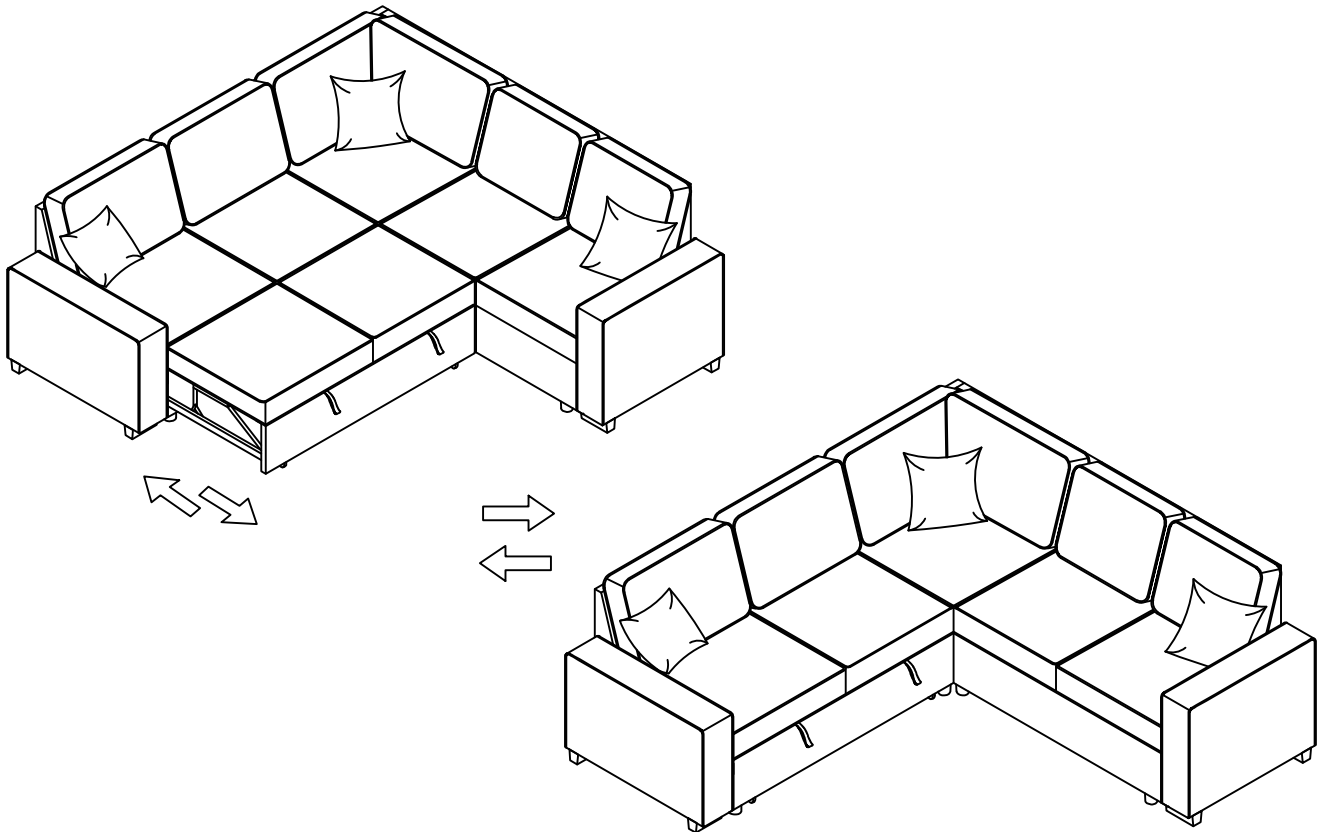

OPTION 2:

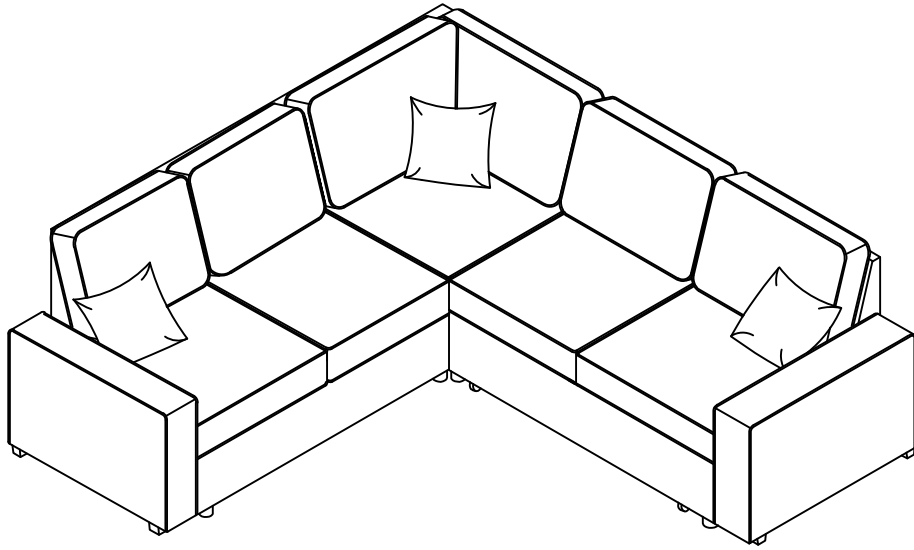

COMPLETED :

