

Reverse Osmosis Water Filtration System

PureEssence ECO

EWP600B0W

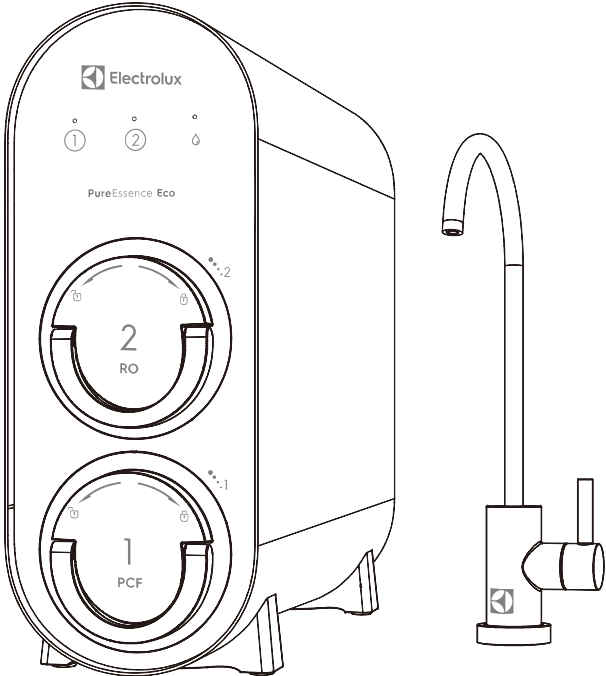



This device complies with part 15 of the FCC Rules. Operation is subject to the following two conditions: (1) This device may not cause harmful interference, and (2) this device must accept any interference received, including interference that may cause undesired operation. Any changes or modifications not expressly approved by the party responsible for compliance could void the user's authorization to operate the equipment.



WARNING

- Please use municipal tap water as the water source. Do not use water that is microbiologically unsafe or of unknown quality without adequate disinfection before or after the system.
- Be sure to handle the system gently and carefully. Do not attempt to modify or repair the system yourself, otherwise, the warranty will become invalid.
- This device is intended for domestic use only.
- The inlet water temperature of the system should be within 40 - 100 °F (5 - 38 °C). When the inlet water temperature exceeds 100 °F (38 °C), the filter could be damaged and become invalid. If the inlet water temperature is lower than 40 °F (5 °C), it may cause freezing and the parts of the system to rupture, resulting in water leakage.
- Do not reverse the installation order of the filter cartridges to avoid affecting the filter performance of the system.
- If the system is abnormal or faulty, stop using it immediately. Close the inlet water valve and turn on the faucet to empty the system. Events of faults include:
 - Leakage
 - The product is cracked or damaged
 - There is an abnormal sound or burnt smell
 - The machine does not work
 - Please contact consumer care for inspection immediately.
- If not using the system for an extended period, turn off the water supply to avoid damage to the system.

SAVE THESE INSTRUCTIONS
Household use only !

CONTENTS

1 Explanation of Symbols and Safety Instructions	06
1.1 Recognize Safety Information	06
1.2 Understand Signal Words	06
1.3 Installation Tips	06
2 General Information	07
2.1 Product Specification	07
2.2 Product Overview and Installation Illustration	08
3 Installation	09
3.1 Installation Instructions	09
3.2 Selecting The Faucet Location	10
3.3 Install The Angle Stop Valve for the Feed Water	11
3.4 Install The Faucet	12
3.5 Install RO Drain Connector	13
3.6 Connecting The System	14
4 Operation	15
4.1 Before the First-time Use	15
4.2 User Interface	15
5 Maintenance	17
5.1 Filter Cartridge Replacement	17
5.2 Automatic Flushing	18
6 Troubleshooting	19
Limited Warranty	21

Thank you for choosing Electrolux. We are the progressive and premium home life brand, making desirable experiences more sustainable. This Installation and Operation Manual is part of our commitment to your experience for the life of your appliance.

Keep a Record for Quick Reference

Purchase date

Electrolux serial number

Electrolux model number

1 Explanation of Symbols and Safety Instructions

This manual has safety information and instructions to help you eliminate or reduce the risk of accidents and injuries.

1.1 Recognize Safety Information

 This is the safety alert symbol. It is used to alert you to potential physical injury hazards. Obey all safety messages that follow this symbol to avoid possible injury or death.

1.2 Understand Signal Words

A signal word will identify safety messages and property damage messages, and also will indicate the degree or level of hazard seriousness.



DANGER

Indicates an imminently hazardous situation which, if not avoided, will result in death or serious injury.



WARNING

Indicates a hazardous situation that, if not avoided, could result in death or serious injury.



CAUTION

Indicates a hazardous situation which, if not avoided, could result in property damage and minor or moderate injury.



NOTICE

This symbol indicates important information where there is no risk to people or property.

1.3 Installation Tips

Please read this manual and the labels on the device before you install, operate, or service it. Then inspect the package. Open the box and take out the reverse osmosis system, all the components and connector fittings. Check the packing list to confirm all accessories are included in the package. Contact customer service if any components are missing or damaged during shipping. If there are any parts cracked or broken, please do not proceed with the installation and contact us. Identify and get familiar with all components for quick installation.



NOTICE

Before installing this reverse osmosis system, make certain your water supply complies with the following operating specifications. Failure to do so may reduce the effectiveness of the system and will void the warranty.

2 General Information

2.1 Product Specification

Model	EWP600
Part No.	EWP600B0W
Daily Production Capacity	600 GPD
Operating Water Temperatures	40-100 °F (5-38 °C)
Operating Water Pressure	15-100 psi (0.1-0.7 MPa)
Power Specifications	Input:100-240V AC Output:24V DC
Feed Water Requirement	Municipal Tap Water
pH Parameters	2-11
TDS (Total Dissolved Solids)	< 1800 ppm
Iron	< 0.2 ppm
Turbidity	< 5 NTU
Hardness	< 10 gpg (170 mg/L)

Hardness: Recommended hardness not to exceed 10 grains per gallon, or 170 parts per million.

Note: System will operate with hardness over 10 grains but the membrane life may be shortened. The addition of a water softener may lengthen the membrane life.

Water Pressure: The operating water pressure in your home should be tested over a 24 hour period to attain the maximum pressure. If the incoming water pressure is above 80 psi then a water pressure regulator is required.

2.2 Product Overview and Installation Illustration

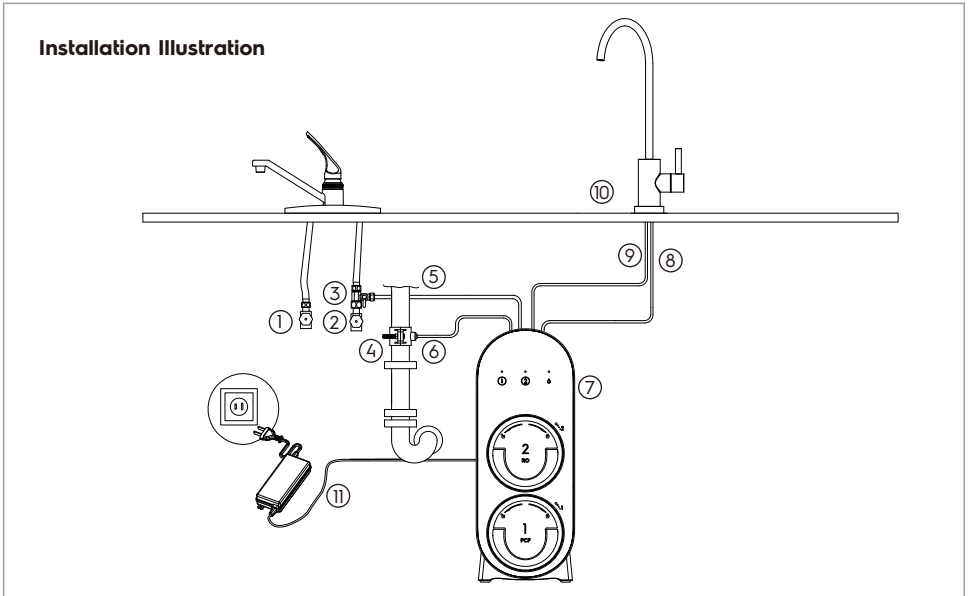
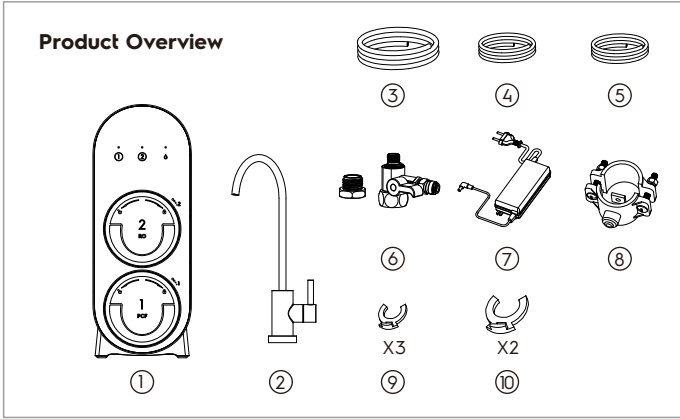

- ① Hot water valve
- ② Cold water valve
- ③ Angle stop valve
- ④ Drain connector
- ⑤ Water inlet tubing
- ⑥ Drain outlet tubing
- ⑦ Reverse osmosis system
- ⑧ Faucet power cord
- ⑨ Filtered water outlet tubing
- ⑩ Faucet
- ⑪ Power adapter

Tools and Materials Required

- Hand or electric drill(cordless preferred)
- Adjustable wrenches
- Slotted and Phillips screwdrivers
- Utility knife or scissors
- Safety glasses
- Drill bits: 1"(for faucet hole), 1/4"(for drain tubing)
- Safety mask



NOTICE

Not all tools may be necessary for installation. Read installation procedures before starting to determine what tools are required.

3 Installation

3.1 Installation Instructions

Read all installation and operating instructions before installing and using your RO system.



NOTICE

- Please check if there is sufficient space for installing the system itself, its accessories, connection.
- Under no circumstances should the system be installed outdoors.
- The environment where the system is installed should adhere to appropriate hygiene and sanitation conditions. Avoid any external dripping liquids from pipes or drains, etc, onto the system.
- This system should be placed on a stable and at the surface.
- Keep the system away from heat. It shall not be placed in a place that may have in-flammable gas leakage.

How to use the quick-connector fitting To connect

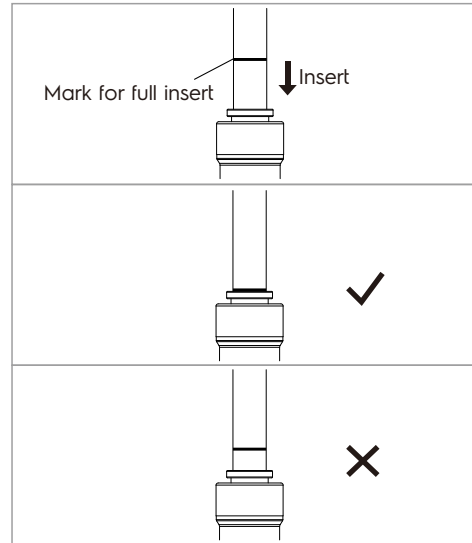

- There is an existing mark at the end of the PE tubing for you to confirm if the PE tubing is fully inserted into the fitting.
- Push the PE tubing into the fitting until you reach the mark on the tubing.



NOTICE

If the PE tubing is not fully inserted, no seal will be created, and leakage will occur.

- When the PE tubing is fully inserted, put the clip on the fitting. It will lock the PE tubing in place and prevent it from falling off.

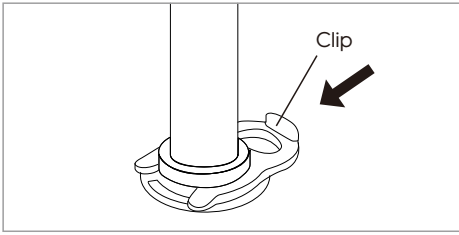

NOTICE

If the PE tubing is too long, cut it to a suitable length with a sharp utility knife or scissors. Cut the PE tubing squarely and cleanly. Make sure the PE tubing is fully inserted.

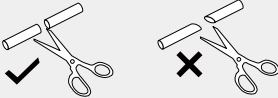

To disconnect

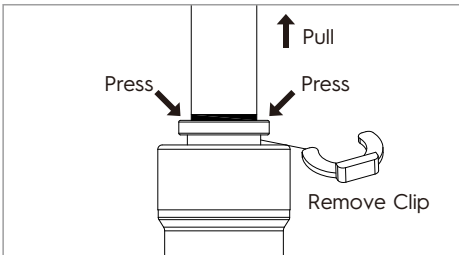

- Remove the blue lock clip from the fitting;
- Use your thumb and index finger to press down the lock sleeve. Use your other hand to pull out the PE tubing from the fitting.



NOTICE

Please do not pull out the PE tubing directly. This will damage the fitting and cause leakage.

3.2 Selecting The Faucet Location

Most sinks have pre-drilled holes designed for spray hoses. The RO faucet may be through using one of these holes despite their larger size. If these pre-drilled holes cannot be used or are in an inconvenient location, it will be necessary to drill a 1" hole in the sink or through the countertop next to the sink.



CAUTION

- This procedure may generate dust, which can cause severe irritation if inhaled or come in contact with the eyes. Safety glasses and a safety mask are recommended for this procedure.
- Do not attempt to drill through an all-porcelain or porcelain-coated sink. For applications on these types of sinks, we recommend using the sprayer hole or drilling the hole through the countertop.
- When drilling through a countertop, make sure the area below the drilled area is free of wiring and piping. Make certain that you have ample room to make the proper connections to the bottom of the countertop.
- Do not drill through a countertop that is more than 1 inch thick.
- Do not attempt to drill through a tiled, marble, granite or similar countertop. Consult a plumber or the countertop manufacturer for advice or assistance.

The following instructions apply to stainless steel sinks ONLY.

- (A) Line the bottom of the sink with newspaper to prevent shavings, parts or tools from falling down the drain.
- (B) Place masking tape over the area to be drilled to help prevent scratches if drill bit slips.
- (C) Mark the point with a center punch. Use a 1/4-inch drill bit to drill a pilot hole through the sink.
- (D) Use a 1" hole saw to enlarge the hole. Smooth rough edges with a file.

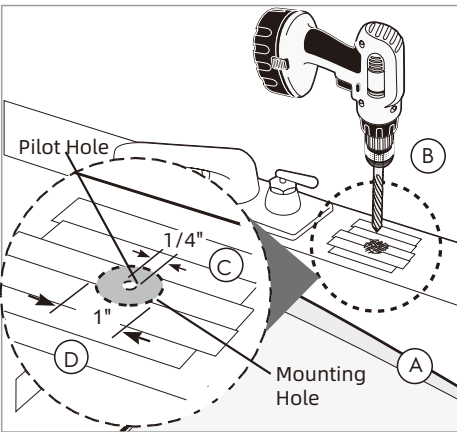

3.3 Install The Angle Stop Valve for The Feed Water

(Fits 1/2" - 14 NPS supply threads or 3/8" compression).

- (A) Turn off the cold water supply valve. Turn on the kitchen cold water faucet to release the pressure and allow water to drain from the line. Disconnect the cold water hose from the cold water valve.

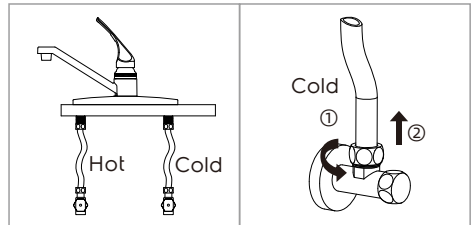

- (B) Insert the 3/8" white PE tubing into the angle stop adapter's fitting. Secure the tubing with a 3/8" clip.

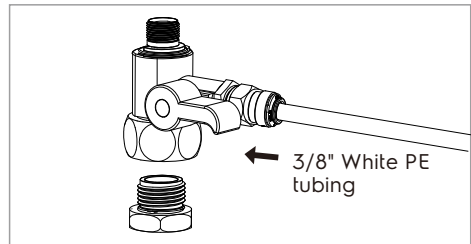

- (C) Install the Angle Stop Valve on the cold water valve and tighten it with an adjustable wrench. Please don't miss the gasket inside the angle stop adapter during installation.



NOTICE

If the cold water tubing is 1/2", screw the conversion adaptor upper the Angle Stop Valve.

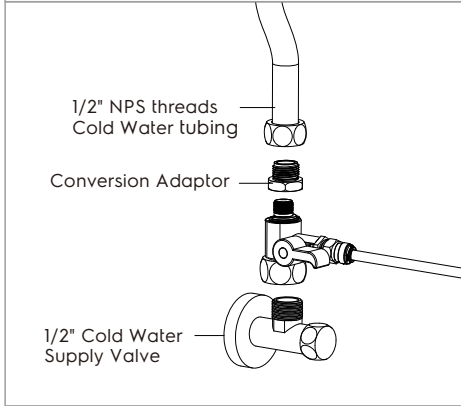
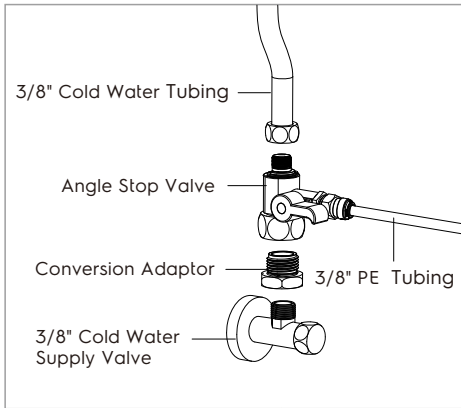

(D) Switch off the angle stop adapter. Turn on the cold water supply valve. Wipe the connections with a tissue to check for leakage. If the tissue stays dry, the angle stop valve is installed correctly.

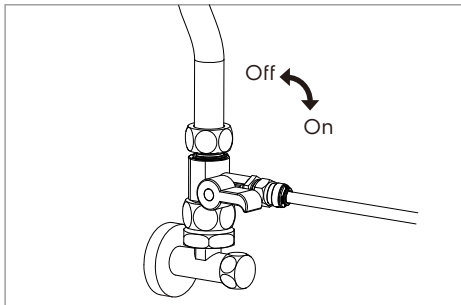

3.4 Install The Faucet



NOTICE

If your kitchen sink or countertop does not have an existing hole, you will have to drill one (1"). Refer to chapter 3.2.

1. Insert the faucet into the hole on the countertop. (As shown in the image below)
2. Under the sink, slip on the nut and tighten it up (Do not forget the washer).

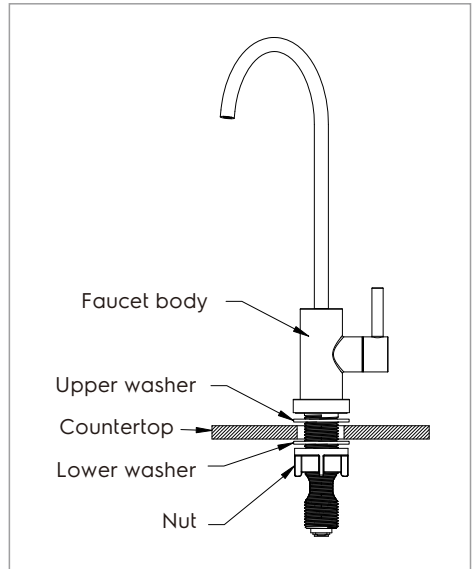

3.5 Install RO Drain Connector

1. Identify drain outlet location.
2. Knock out the center hole on the foam seal (④).
3. Use the hole in the foam seal (④) as a template to locate your drilling position above the drain tap. Mark the location with a pencil. Note: If you have a double sink and cross- or horizontal drain tubing, it is safe to mark the drill location on the top of the horizontal drain tubing.
4. At the marked location, drill a 1/4" hole through the wall of the drain tubing, being sure not to penetrate the opposite side of the tubing.
5. Remove the protective cover from the back of the foam seal (④) and attach it to the front plate of the drain connector (①) in alignment with the holes.
6. Begin to position the drain connector (①) on the sink drain tubing with Screws (②) and Nuts (③), using your pencil (or a thin pen) in the drain connector (①) tube hole to guide your location over your drilled hole as you securely tighten Nuts (③) and Screws (②).

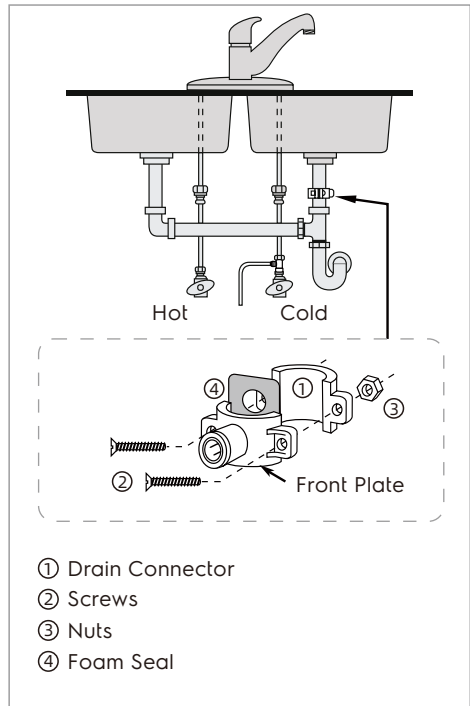

NOTICE

Remove the pencil once the location is established.

3.6 Connecting The System

1. Before connecting the PE tubing to the system, ensure you have removed the plug from the water port.
2. Connecting the tubing to the System
 - a. Connect the 3/8" White Tubing from the Angle stop valve to the "Raw Water" port.
 - b. Connect the 1/4" Blue Tubing from the Faucet to the "Pure Water" port.
 - c. Insert 1/4" Red Tubing from the Drain connector to the "Drain Water" port.
3. Insert the faucet power cord which is connected to the faucet into the "FAUCET" connector at the back of the housing and tighten the nut.



NOTICE

DO NOT insert the plug into the socket yet.

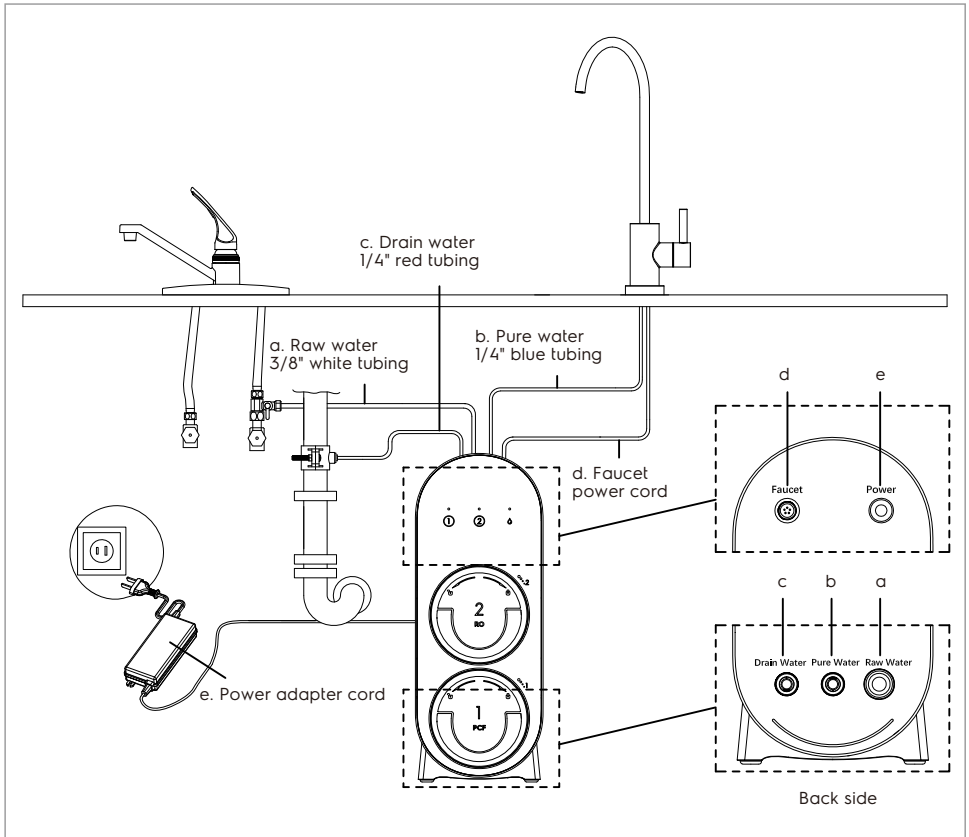

4 Operation

4.1 Before The First-time Use

- (A) Turn on the cold water supply and ensure the supply adapter valve is open.
- (B) Connect the system with power. You will hear a long beep, and all indicators will light up for 3s. The system will automatically flush for 30s.

Wipe all the joints and connections with tissue to check for leakage. If the tissue stays dry, the system is installed correctly.

- (C) After the auto-flush is completed, turn on the faucet to allow water to run for 30 minutes to flush the air and carbon fines through the filters. After that, the system is ready, and you can start to consume the pure water.





NOTICE

Initially, the water may appear cloudy. This is a result of air trapped in the RO filter. It is not harmful and will disappear in a matter of minutes. It may take up to a week after installing a new RO filter for the trapped air to dissipate.

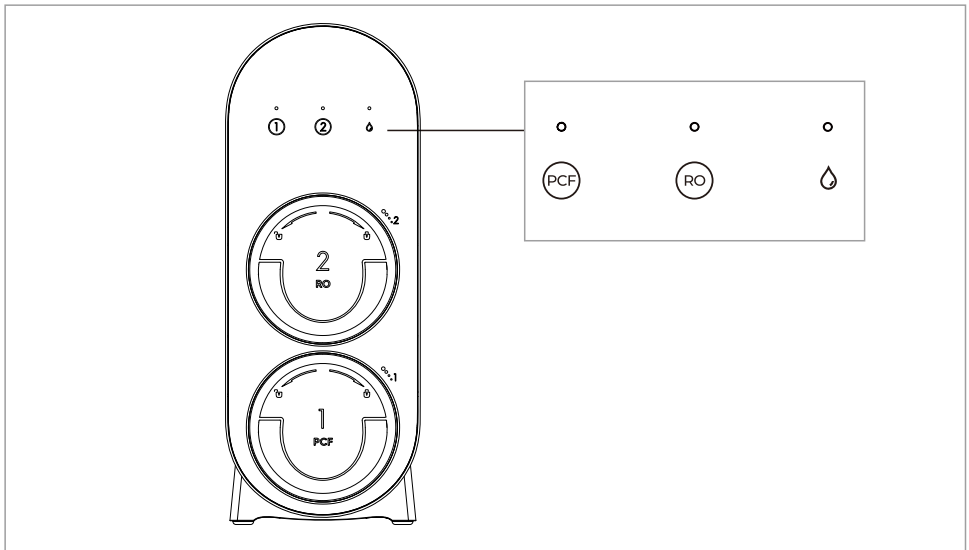
4.2 User Interface



Indicator	Indication	Status
 PCF lifetime indicator & Reset button	Solid blue light	Lifetime > 5%
	Flashing red light	0 < Lifetime ≤ 5%
	Solid red light	Lifetime = 0
 RO lifetime indicator & Reset button	Solid blue light	Lifetime > 5%
	Flashing red light	0 < Lifetime ≤ 5%
	Solid red light	Lifetime = 0
 Wording Status indicator	Solid blue light	System working normally
	Flashing blue light	System is flushing
	Flashing Red light	System malfunction

  **Reset Button**

To reset the filter lifespan, press and hold the reset button for 3 seconds until you hear a beep. The indicator will flash blue, confirming that the filter lifespan has been reset.

Faucet Indicator

Solid blue light	Flashing blue light	Flashing red light	Solid red light
Filter lifetime is normal	System is flushing	Replace filter soon	Replace filter now

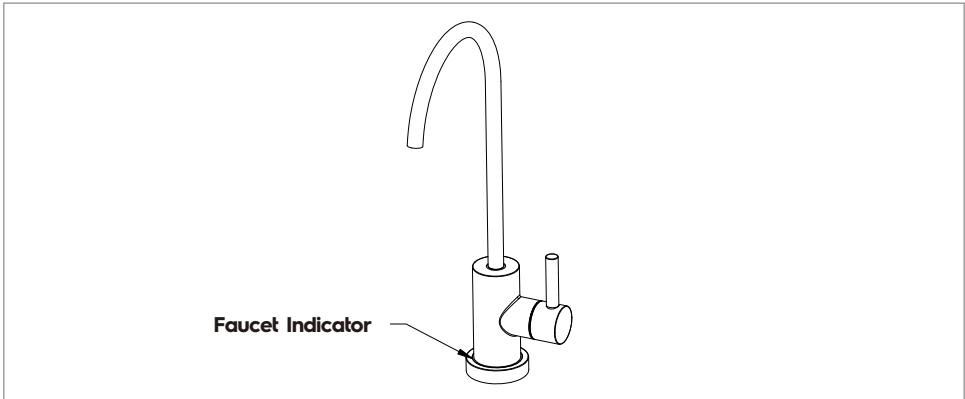

5 Maintenance

If you plan on not using the system for one week or longer, take out the filter and seal it with plastic wrap. Store the sealed filter in the fridge to protect the system against microbiological growth. To start the system again after the period of non-use, flush the system for at least 10 minutes OR change the filters.

If you will not use the system for two weeks or longer, disconnect the water supply, drain the system, and disconnect the power.

Follow the recommended filter replacement schedule. Replace the filter any time the indicator is on. Note that the actual filter life depends on the family size and water source quality. Failure to replace the filter at the appropriate times can damage the system and potentially cause health hazards.

Filter Service Life Table

Filter	Recommended replacement cycle
PCF Filter	12 months/1,000 gallons
RO Filter	24 months/2,000 gallons

The actual lifetime of the filter cartridge depends on the local tap water quality and daily usage.

The recommended replacement cycle is an average based on different local tap water quality. If the local tap water quality is below the average, the actual lifetime of the cartridge would differ from the recommended replacement cycle. If the filter cartridge is blocked, please replace it.

5.1 Filter Cartridge Replacement



NOTICE

The life of the filter cartridges depends on the water volume used and the quality of the feed water. For the best performance, please change your filter cartridge according to the filter lifetime indicator or the filter replacement cycle suggested below. When there is a noticeable change in taste, odor, or flow of filtered water, we recommend changing the filters as well.

Filter cartridge replacement

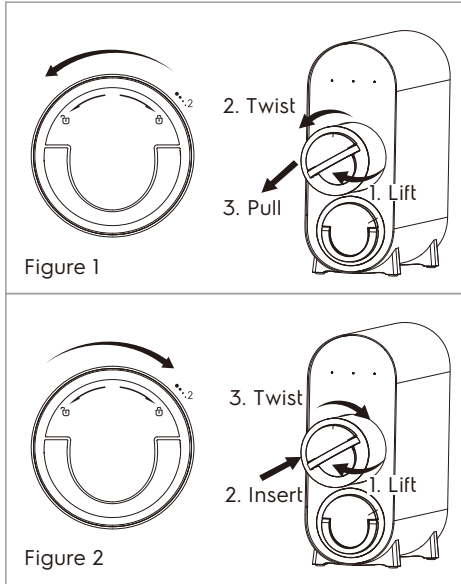

- Turn off the power and water supply before replacing the filter cartridges
- Lift the handle of the filter cartridge. Twist it anticlockwise and pull it out (Figure 1).
- Remove the packaging of the new filter and insert the cartridge in the system. Lift the handle of the filter cartridge and twist it clockwise to align the lock icon. Then put the handle back (Figure 2).
- Reset the filter lifespan, press and hold the reset button 3 seconds. The indicator will flash blue, confirming that the filter lifespan has been reset.
- When the filter is replaced, turn on the faucet and allow water to flush the filter.

Flush times are as follows:

PCF filter: 10 minutes

RO filter: 30 minutes

5.2 Automatic Flushing

The reverse osmosis membrane features a filtration capacity as fine as 0.0001 microns, effectively removing contaminants. The flush mode helps expel accumulated contaminants from the membrane, ensuring a longer filter lifespan and delivering purer water. The system will automatically enter flush mode in the following situations:

1. Flush for Power Restore

When power is restored after a blackout, the system will be forced to be flushed automatically for 30 seconds.

2. Flush for Accumulative Time per 24 hours

To maintain and extend the life expectancy of the filters, the system will be automatically flushed for 30 seconds per 24 hours.

The flush mode doesn't affect the user when taking water. If the user decides to take water during the flushing, the system will quit flushing and switch to dispensing.

6 Troubleshooting

Problem	Possible cause	Solution
No water comes out from the faucet.	Cold water valve or the angle stop valve is turned off.	Turn on the valves.
	The system is not connected with power.	Check if the power adapter is connected to the system and the power socket properly.
The flow rate gets slower.	Filter is blocked.	Replace the filter.
	The tubing is bent.	Make sure the tubing is straightened.
	Inlet water pressure is low.	Wait until the inlet water pressure gets stable, or install a pressure boost before the system if the inlet water pressure is constantly lower than 15 psi.
Poor outlet water quality.	Filter has reached the end of life.	Replace the filter.
	The system hasn't been used for some time.	Turn on the faucet and allow the water to run for 5 minutes.
	The inlet water quality is poor.	Always use municipal tap water as the water source. Do not use water that is microbiologically unsafe or of unknown quality without adequate disinfection before or after the system.
System indicators all flash, the buzzer keep beeps.	The system has been filtering water continuously for 1 hours.	Unplug the system, wait for 1 minute, and plug in again to shoot the trouble.
	The PCB board is damaged.	Contact customer services.
No water runs to the drain.	The drain tubing is bent.	Make sure the tubing is straightened, or replace with a new tubing.
	System malfunctions.	Contact consumer services.
There is leakage.	The tubing are not connected properly.	Reconnect the tubing.
	System malfunctions.	Contact customer services.

Problem	Possible cause	Solution
High TDS of the filtered water.	The system hasn't been used for a long time.	Open the RO faucet, allow it to run for a while. The TDS valve will return to normal.
	The RO filter expired.	Replace the RO filter immediately.
	The drain pipe is bent.	Make sure the tubing is straightened, or replace with a new tubing.
	The source water may have a high TDS.	Test the source water and filtered water. The filtered water's TDS shall be about 0%-10% of your source water's TDS. This is a normal range. If there is a high TDS in the source water, it may reduce the service life of the system.
Loud sound	The system is not positioned in a flat area.	Reconnect the tubing.
	The system is placed against the cabinet.	Not place the system against the cabinet. The system may vibrate when it works.
	The water pressure is unstable.	Check and confirm the water pressure is between 14.5 PSI and 100 PSI. The sound will decrease when the water pressure becomes stable.

Limited Warranty

Your appliance is covered by a one year limited warranty. For one year from your original date of purchase, Electrolux will repair or replace any parts of this appliance that prove to be defective in materials or workmanship when such appliance is installed, used, and maintained in accordance with the provided instructions.

Exclusions:

This Warranty does not cover the following:

1. Products with original serial numbers that have been removed, altered or cannot be readily determined.
2. Product that has been transferred from its original owner to another party or removed outside the USA or Canada.
3. Rust on the interior or exterior of the unit.
4. Products purchased "as-is" are not covered by this warranty.
5. Food loss due to any refrigerator or freezer failures.
6. Products used in commercial setting.
7. Service Calls which do not involve malfunction or defects in materials or workmanship, or for appliances not in ordinary household use or used other than in accordance with the provided instructions.
8. Service Calls to correct the installation of your appliance or to instruct you how to use your appliance.
9. Expenses for making the appliance accessible for servicing, such as removal of trim, cupboards, shelves, etc., which are not part of the appliance when it is shipped from the factory.
10. Service calls to repair or replace appliance light bulbs, air filters, water filters, other consumables, or knobs, handles, or other cosmetic parts.
11. Labor or in-home service costs during the additional limited warranty periods beyond the first year from your original date of purchase.
12. Pickup and delivery costs; your appliance is designed to be repaired in the home.
13. Surcharges including, but not limited to, any after hour, weekend, or holiday service calls, tolls, ferry trip charges, or mileage expense for service calls to remote areas, including the state of Alaska.
14. Damages to the finish of appliance or home incurred during transportation or installation, including but not limited to floors, cabinets, walls, etc.
15. Damages caused by: services performed by unauthorized service companies; use of parts other than genuine Electrolux parts or parts obtained from persons other than authorized service companies; or external causes such as abuse, misuse, inadequate power supply, accidents, fires, or acts of God.

DISCLAIMER OF IMPLIED WARRANTIES; LIMITATION OF REMEDIES

CUSTOMER'S SOLE AND EXCLUSIVE REMEDY UNDER THIS LIMITED WARRANTY SHALL BE REPAIR OR REPLACEMENT AS PROVIDED HEREIN. CLAIMS BASED ON IMPLIED WARRANTIES, INCLUDING WARRANTIES OF MERCHANTABILITY OR FITNESS FOR A PARTICULAR PURPOSE, ARE LIMITED TO ONE YEAR OR THE SHORTEST PERIOD ALLOWED BY LAW, BUT NOT LESS THAN ONE YEAR. ELECTROLUX SHALL NOT BE LIABLE FOR CONSEQUENTIAL OR INCIDENTAL DAMAGES SUCH AS PROPERTY DAMAGE AND INCIDENTAL EXPENSES RESULTING FROM ANY BREACH OF THIS WRITTEN LIMITED WARRANTY OR ANY IMPLIED WARRANTY. SOME STATES AND PROVINCES DO NOT ALLOW THE EXCLUSION OR LIMITATION OF INCIDENTAL OR CONSEQUENTIAL DAMAGES, OR LIMITATIONS ON THE DURATION OF IMPLIED WARRANTIES, SO THESE LIMITATIONS OR EXCLUSIONS MAY NOT APPLY TO YOU. THIS WRITTEN WARRANTY GIVES YOU SPECIFIC LEGAL RIGHTS. YOU MAY ALSO HAVE OTHER RIGHTS THAT VARY FROM STATE TO STATE.

If You Need Service

Keep your receipt, delivery slip, or some other appropriate payment record to establish the warranty period should service be required. If service is performed, it is in your best interest to obtain and keep all receipts. Service under this warranty must be obtained by contacting Electrolux at the email or phone numbers.

This warranty only applies in the USA and Canada, excluding Alaska, Hawaii, and any location outside of the continental US and Canada. Electrolux authorizes no person to change or add to any obligations under this warranty. Obligations for service and parts under this warranty must be performed by Electrolux or an authorized service company. Product features or specifications as described or illustrated are subject to change without notice.



Service email: service@electrolux-water.com
Telephone number: 1-539-252-8865

Electrolux is a pending or registered trademark from AB Electrolux (publ)
used under license by Tecasa (Zhongshan) Trade Development Co., Ltd.