

ASSEMBLY INSTRUCTION

SWING

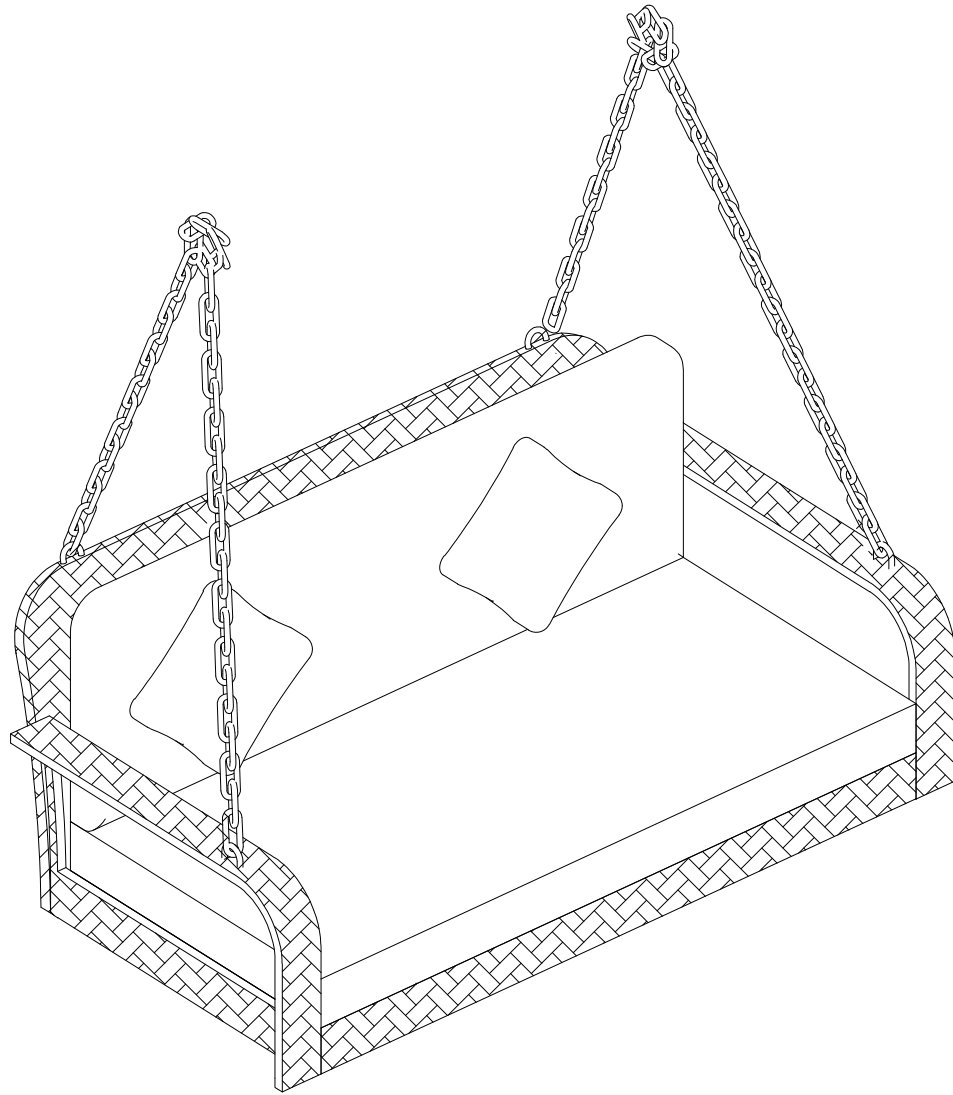

WF320681

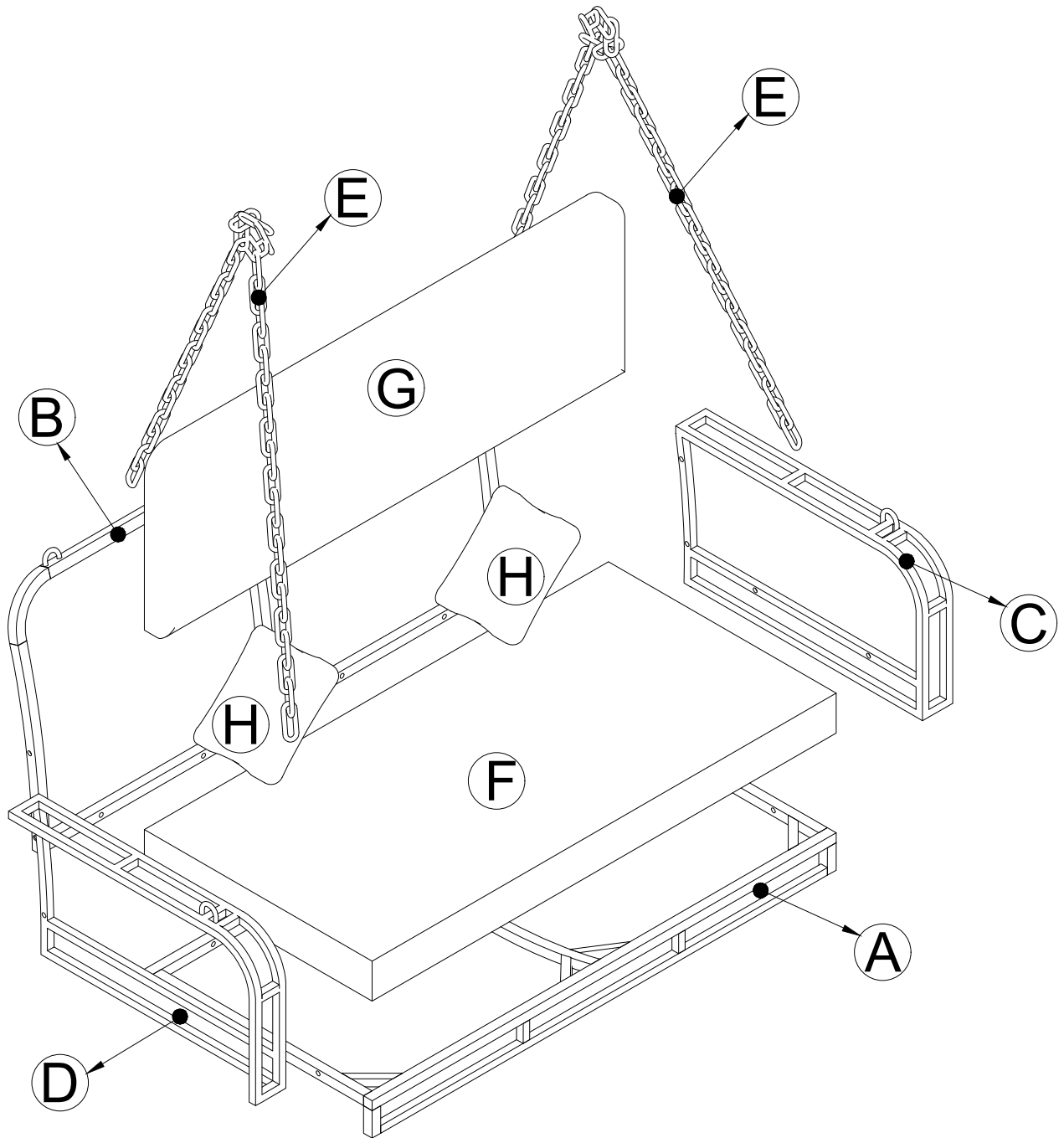

Notes:

1. 50% Tighten before fixing all screws, Allen wrench is recommended instead of an electric drill..
2. Place the item on a flat ground to adjust and make sure it remains stable.
3. Tighten up all screw with tools gradually.
4. If screw are not aligned with holes during assembly, please loosen all the other screws to 50% and continue the assembly process.
5. If the item is not stable, please loosen all screws, adjust it on a flat ground and tighten up all screws again.
6. Note: If one or some screws are fully tighten during assembly, chances are the others will not be aligned with holes. In addition, all the holes are designed to be relatively larger to provide more space for the adjustment of the screws.

CARTON CONTENT:

WF320681

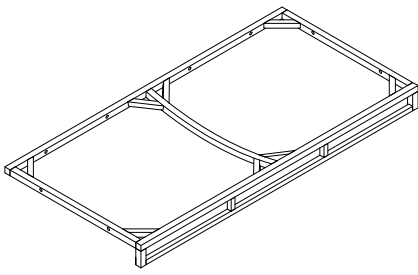

Ax1

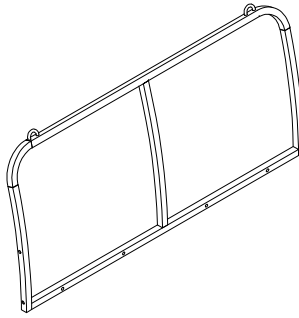

Bx1

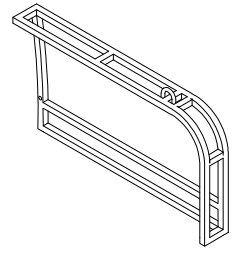

Cx1

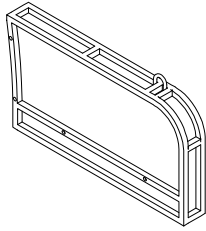

Dx1

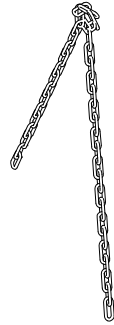

Ex2

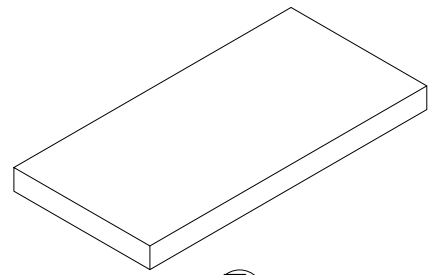

Fx1

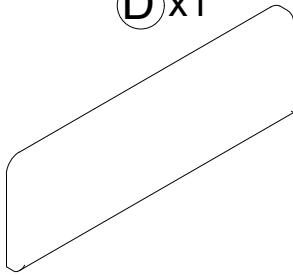

Gx1

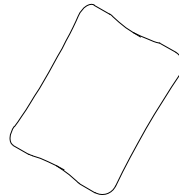

Hx2

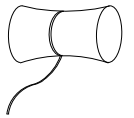



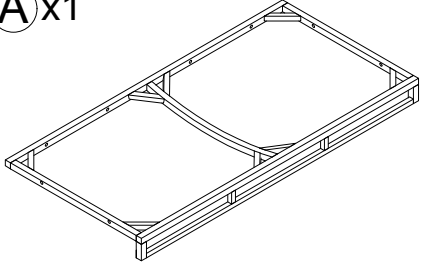
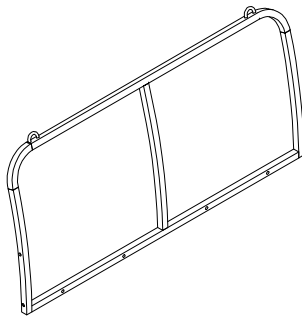
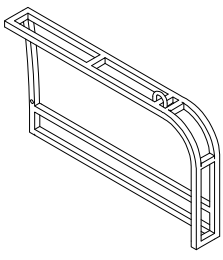
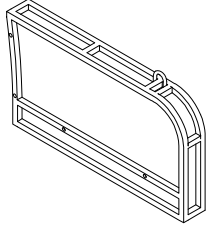
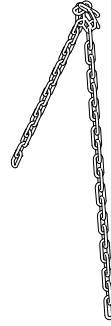
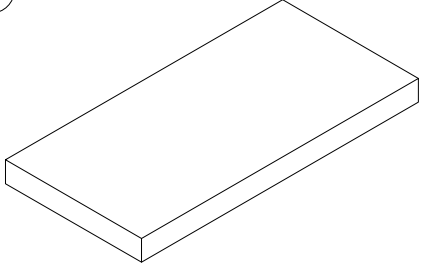
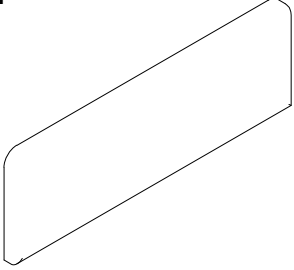
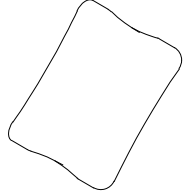
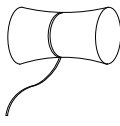

Hardware

Past List:

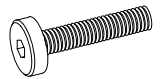
<p>A x1</p>  <p>SEAT FRAME</p>	<p>B x1</p>  <p>BACK FRAME</p>	<p>C x1</p>  <p>LEFT FRAME</p>
<p>D x1</p>  <p>RIGHT FRAME</p>	<p>E x2</p>  <p>SUPPORT WIRE</p>	<p>F x1</p>  <p>SEAT CUSHION</p>
<p>G x1</p>  <p>BACK CUSHION</p>	<p>H x2</p>  <p>PILLOT</p>	<p>HARDWARE</p> 

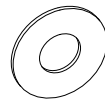
Hardware Liste:

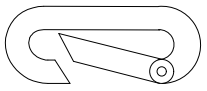
<p>1 x 2 pcs</p>  <p>BOLT M6x30MM</p>	<p>2 x 12 pcs Extra 2 pcs</p>  <p>BOLT M6x35MM</p>	<p>3 x 14 pcs Extra 2 pcs</p>  <p>WASHER M6</p>	<p>4 x 1 pc</p>  <p>ALLEN KEY</p>
<p>5 x 4 pcs</p>  <p>CONNECTOR</p>			

Step 1:

- Ⓐ x 1
- Ⓑ x 1
- ② x 4
- ③ x 4

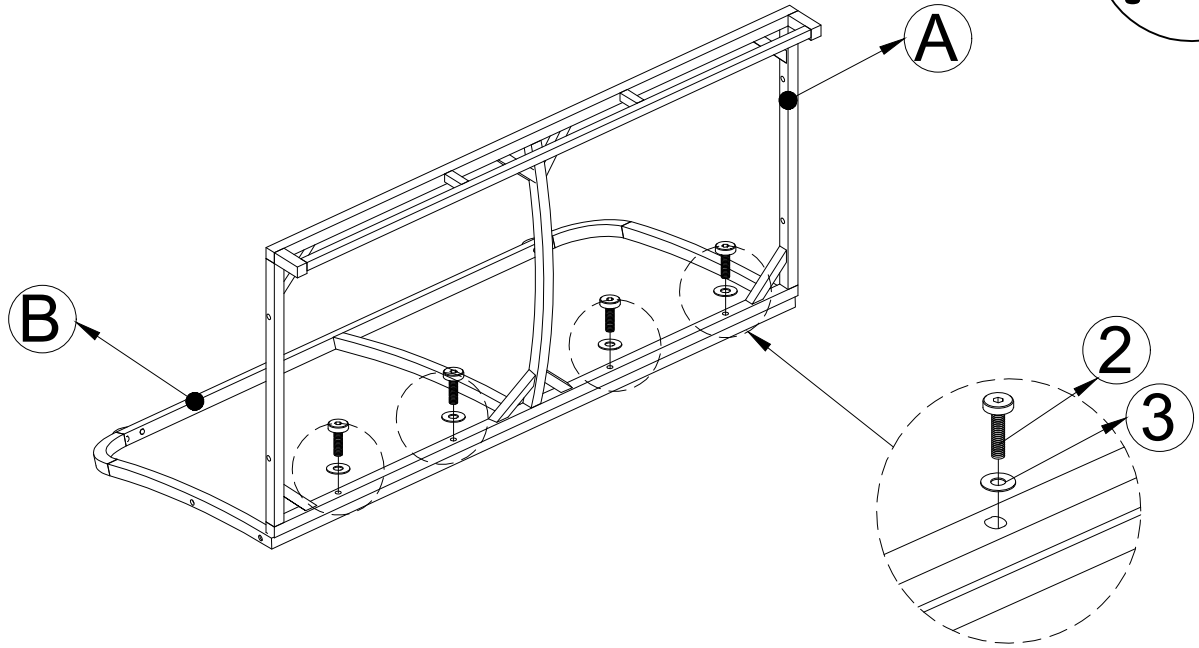

Connect The Seat Frame (A) & Back Frame (B) tighten Bolt (2), Flat Washer (3) with Allen Key (4).

Step 2:

- Ⓒ x 1
- ① x 1
- ② x 2
- ③ x 3

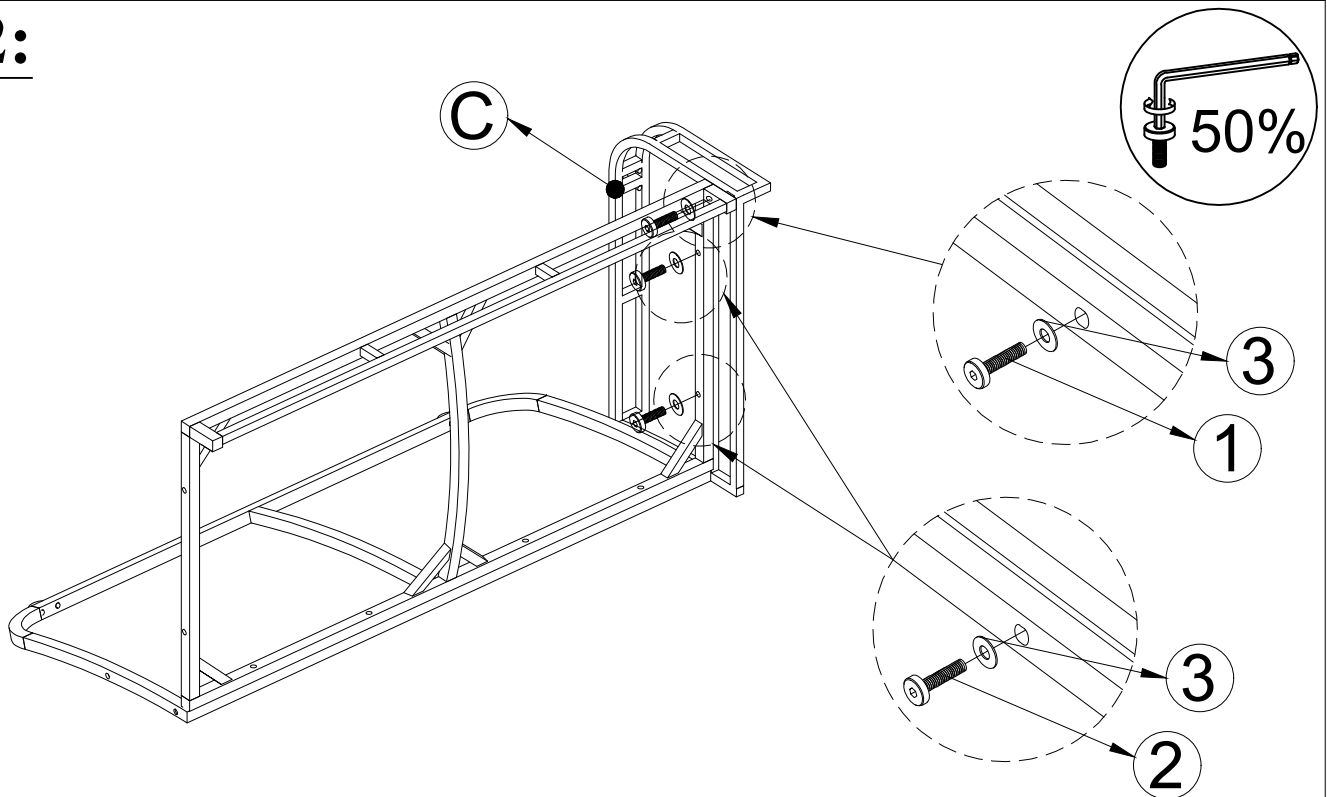

Connect The Part from Step 1 & Right Frame (D), tighten Bolt (1), tighten Bolt (2), Flat Washer (3) with Allen Key (4).

Step 3:

Ⓓ x 1

① x 1

② x 2

③ x 3

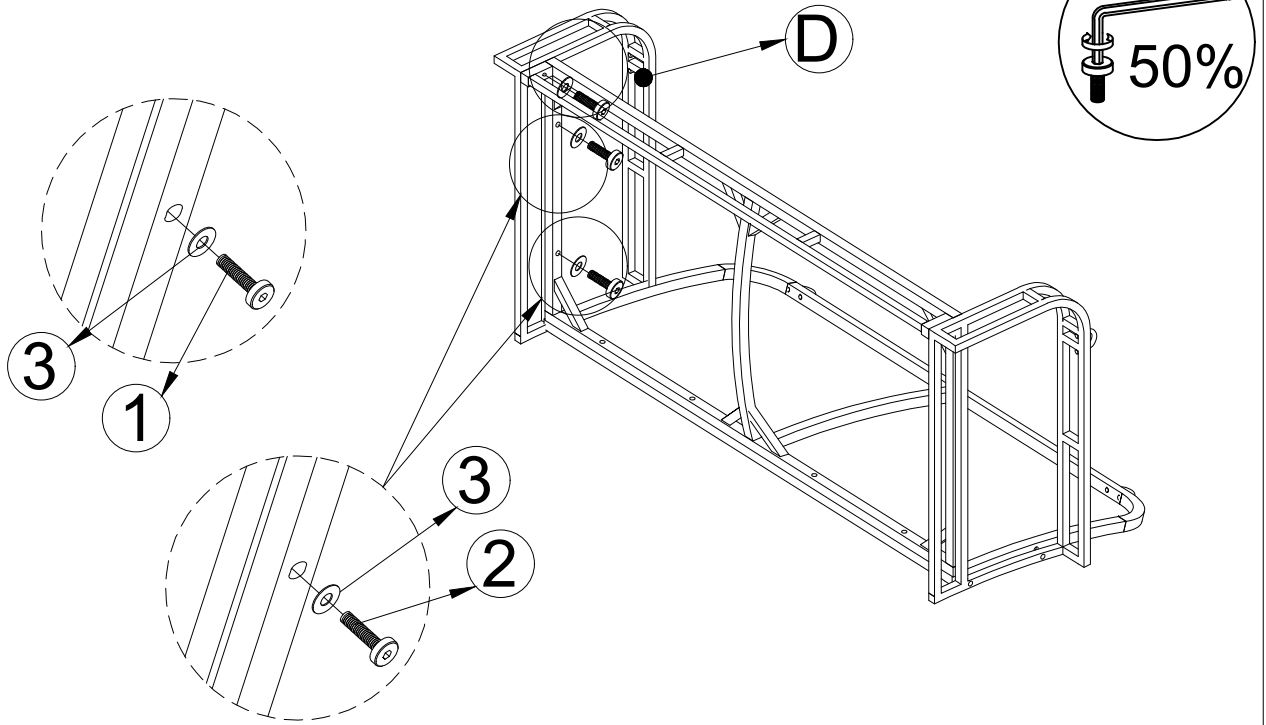

Connect The Part from Step 2 & Right Frame (D), tighten Bolt (1), tighten Bolt (2), Flat Washer (3) with Allen Key (4).

Step 4:

② x 4

③ x 4

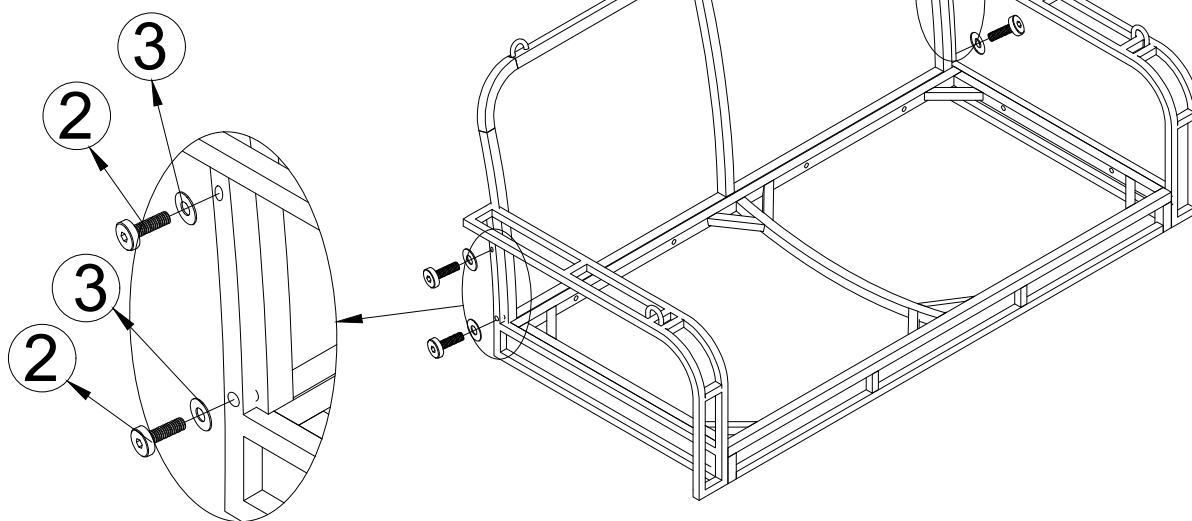

Use Bolts (2) and Flat Washer (3) with Allen Key (4) to reconnect the remaining positions. Tighten all bolts.

Step 5:

Ⓔ x 2

Ⓟ x 4

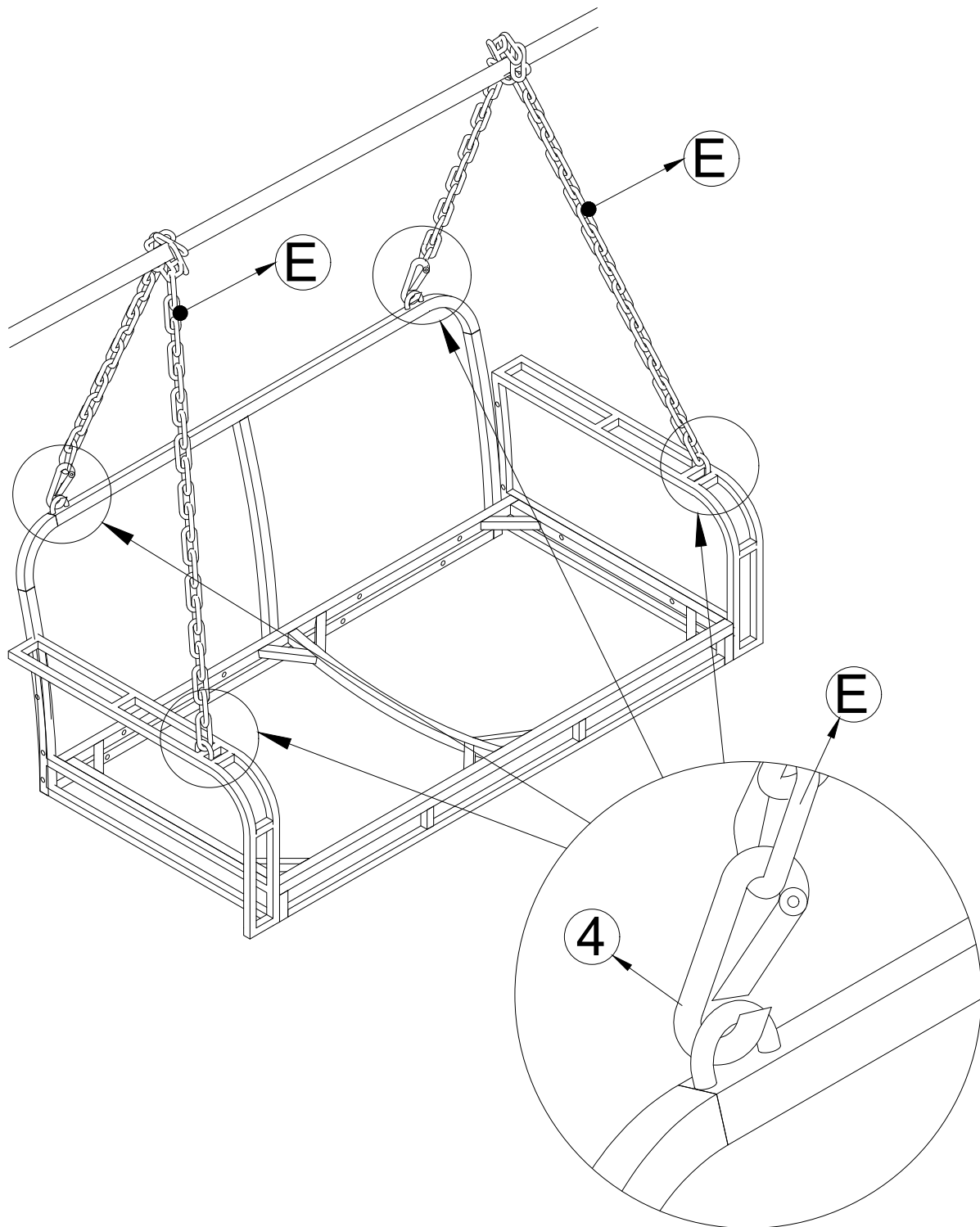

Connect The Part from Step 4 & Support Wire (E) with Connector (5). Hang the swing with Support Wire.

Step 6:

ⓕ x 1

ⓖ x 1

ⓓ x 2

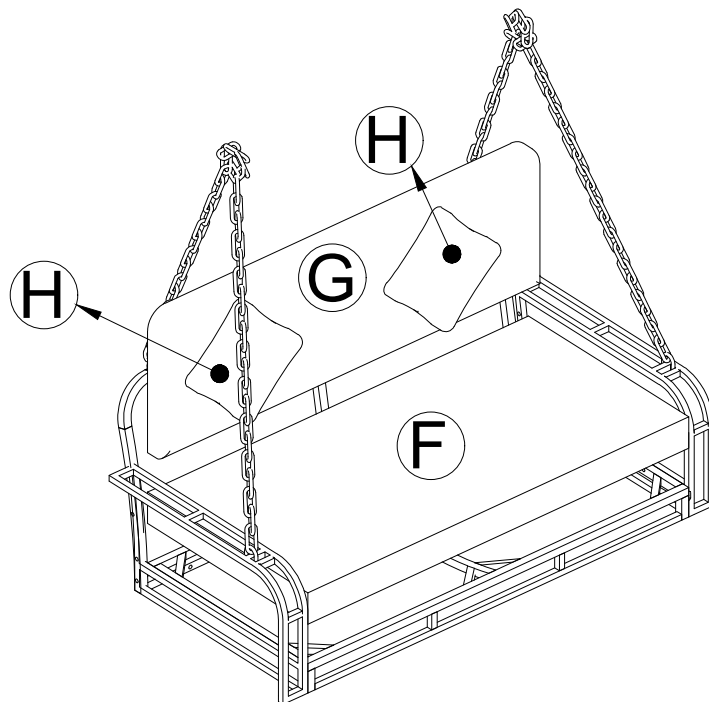

Put on Seat Cushion (F), Back Cushion (G), Pilot (H) to Swing.

Step 7:

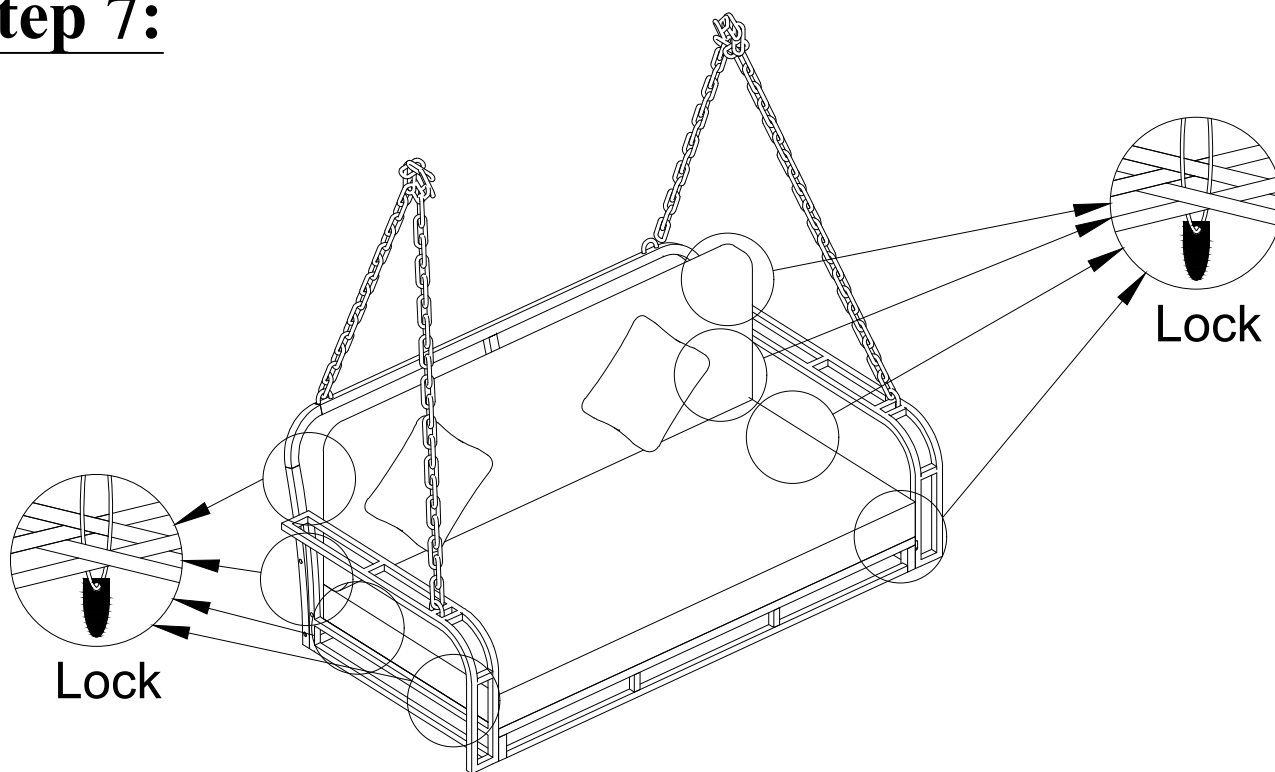

Secure the seat cushion and back cushion with lock. Completed.