

## ASSEMBLY INSTRUCTIONS

# MOD-7203

V0.07.29.24

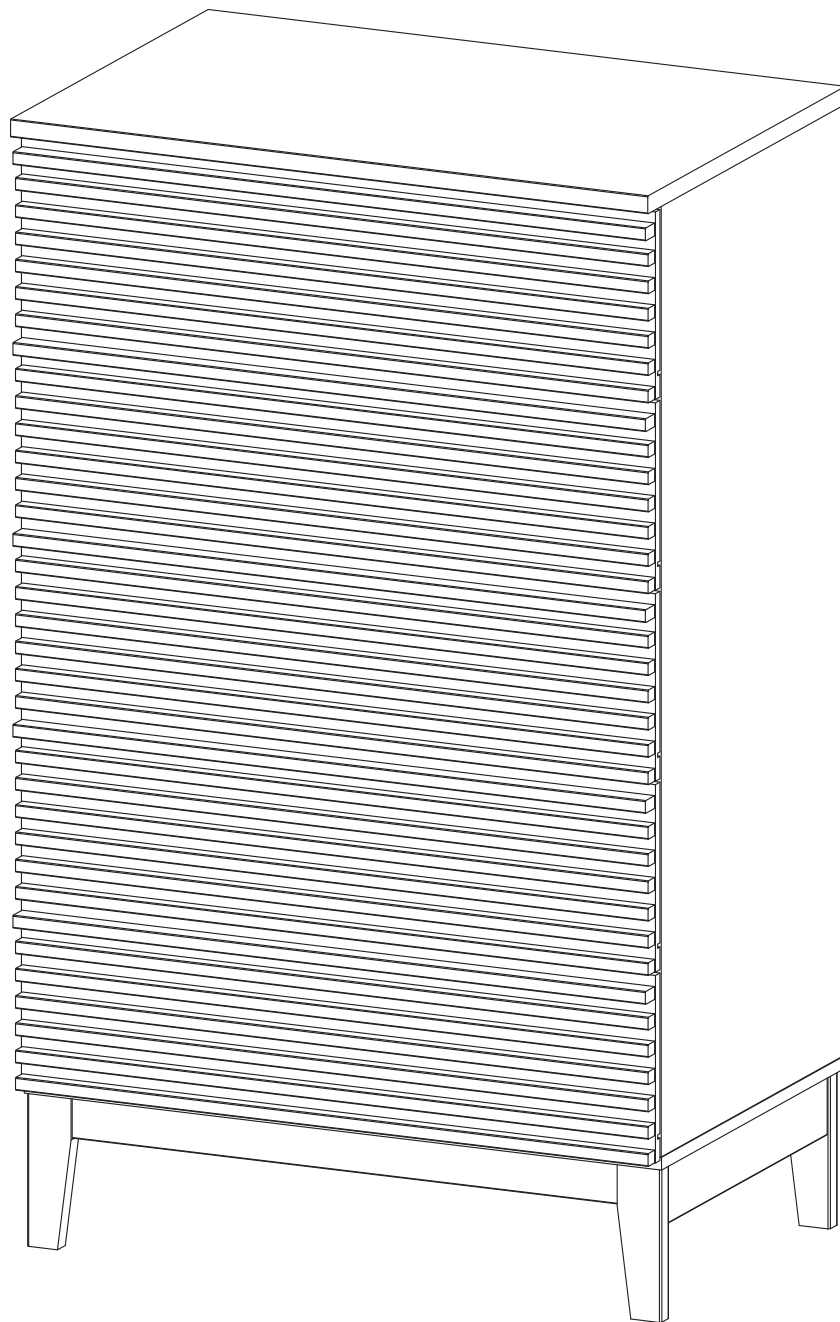

**Questions? Contact us!**

609.256.9000 • [cs@modway.com](mailto:cs@modway.com)  
[www.modway.com](http://www.modway.com)

\*modway

# Let's get started!

\*modway



Read through all of the instructions before starting



Care instructions are listed in the last step of this manual



Approx. 60 minutes assembly time



Make sure you have all parts and components before discarding any packing materials



2 people recommended for assembly

**Only use hand tools to assemble this item.** Do not use power tools. Do not tighten bolts or screws completely until all hardware is lined up and inserted into the holes.

Do not over-tighten screws and bolts to avoid stripping the hardware or cracking the item.

Assemble your item on a flat, carpeted area, with plenty of space to work. This will prevent damage and scratches to your floors or the item while you're assembling the product.

Keep all components and packaging out of reach of children or animals to avoid risk of choking or suffocation.

## Furniture components:



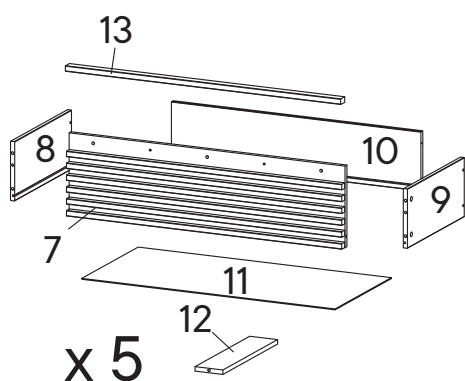
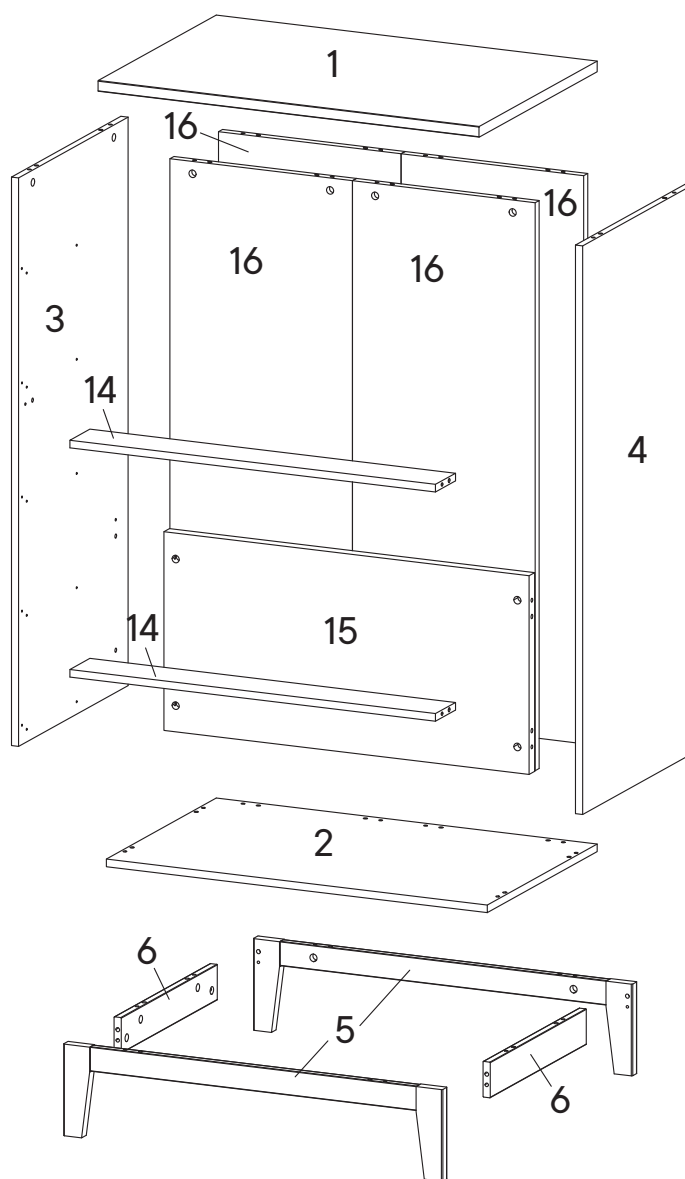











1	Top Board	x1	11	Bottom Drawer	x5
2	Bottom Board	x1	12	Support Drawer	x5
3	Side Board Left	x1	13	Handle	x5
4	Side Board Right	x1	14	Support Board	x2
5	Assembly Leg	x2	15	Counter Weight Board	x1
6	Bottom Skirt	x2	16	Back Board	x4
7	Front Drawer	x5			
8	Side Drawer Left	x5			
9	Side Drawer Right	x5			
10	Back Drawer	x5			

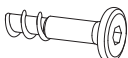

Wait!

Missing parts or hardware? Need assistance?  
Contact us before returning your item. We're here to help!  
609.256.9000 • cs@modway.com

## Provided hardware:

A		Cam Bolt Ø6 x 35 mm	x28	J		Screw M 3.5 x 13 mm	x30
B		Cam Lock Ø15 mm	x28	K		Screw M 8 x 39 mm	x30
C		Cam Lock Ø12 mm	x25	L		Screw M 3.5 x 15.5 mm	x20
D		Wood Dowel Ø8 x 30 mm	x42	M		Wedge	x20
E		Wood Dowel Ø6 x 30 mm	x10	N		Floor Protector	x4
F		Wood Dowel Ø5 x 20 mm	x10	O		Screw M 6.4 x 25 mm	x15
G		Cam Bolt Ø6 x 32 mm	x25	P		Screw M 6 x 10.5 mm	x30
H		Screw M 7 x 50 mm	x8	RM35A		Drawer Runner	x5
I		Allen Key	x2				

## What you need:



## Components Carton Placement

### Carton 1 of 2

Label	Description	Qty
3	Side Board Left	x1
4	Side Board Right	x1
8	Side Drawer Left	x5
9	Side Drawer Right	x5
12	Support Drawer	x5
16	Back Board	x4
	Hardware Pack	x2

### Carton 2 of 2

Label	Description	Qty
1	Top Board	x1
2	Bottom Board	x1
5	Assembly Leg	x2
6	Bottom Skirt	x2
7	Front Drawer	x5
10	Back Drawer	x5
11	Bottom Drawer	x5
13	Handle	x5
14	Support Board	x2
15	Counter Weight Board	x1

# Step 1

## HARDWARE

- E** Wood Dowel Ø6 x 30 mm x10
- F** Wood Dowel Ø5 x 20 mm x10
- G** Cam Bolt Ø6 x 32 mm x25

## COMPONENTS

- 7** Front Drawer x5
- 8** Side Drawer Left x5
- 9** Side Drawer Right x5
- 13** Handle x5

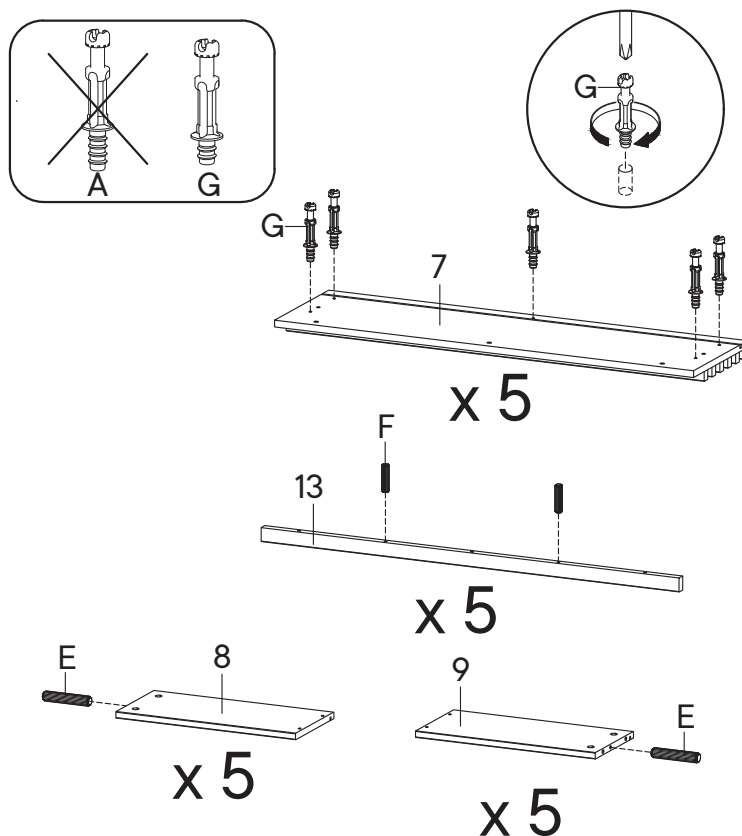

# Step 2

## HARDWARE

- C** Cam Lock Ø12 mm x25
- K** Screw M 8 x 39 mm x30

## COMPONENTS

- 7** Front Drawer x5
- 8** Side Drawer Left x5
- 9** Side Drawer Right x5
- 10** Back Drawer x5
- 11** Bottom Drawer x5
- 12** Support Drawer x5

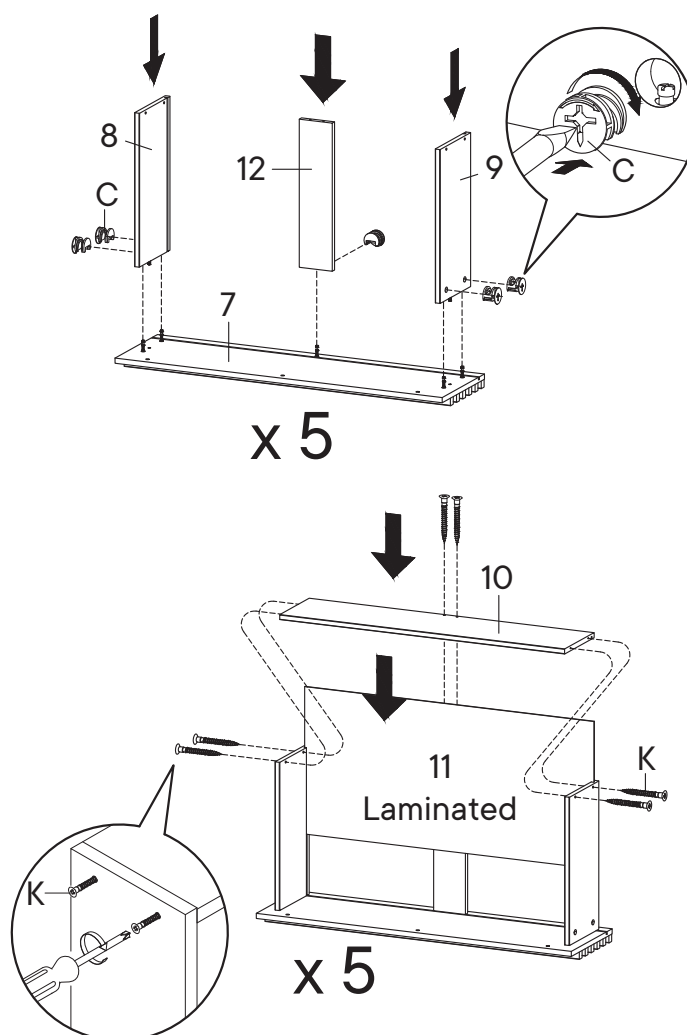

# Step 3

## HARDWARE

- J** Screw M 3.5 x 13 mm x30
- L** Screw M 3.5 x 15.5 mm x20
- M** Wedge x20
- RM35A** Drawer Runner x5

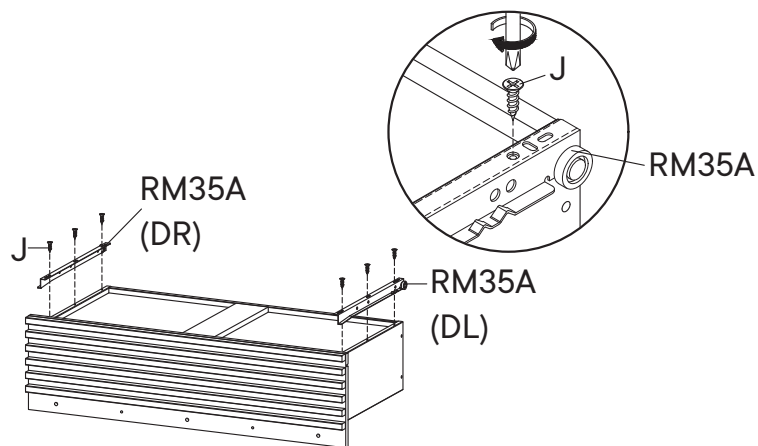

x 5

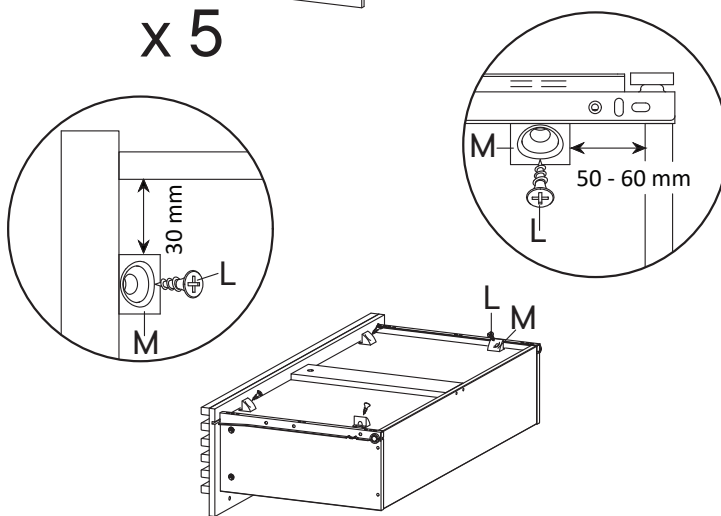
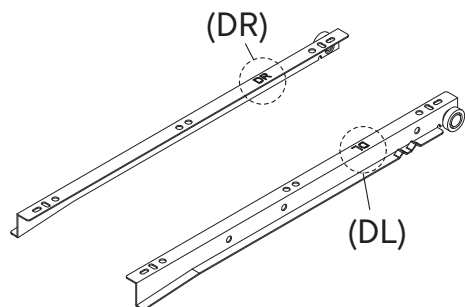

x 5

# Step 4

## HARDWARE

- I** Allen Key x1
- O** Screw M 6.4 x 25 mm x15

## COMPONENTS

- 13** Handle x5

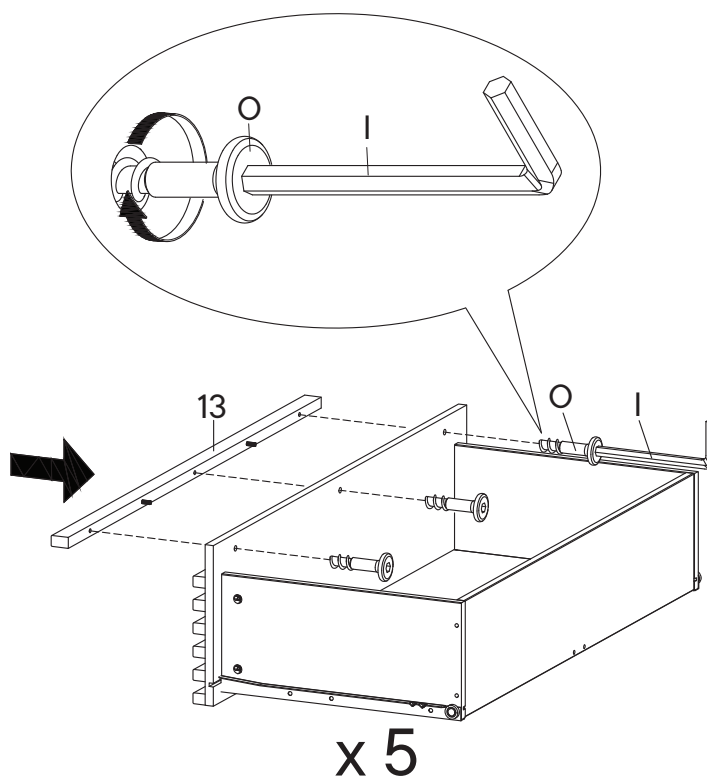

x 5

# Step 5

## HARDWARE

- A** Cam Bolt Ø6 x 35 mm x16
- D** Wood Dowel Ø8 x 30 mm x12

## COMPONENTS

- 1** Top Board x1
- 3** Side Board Left x1
- 4** Side Board Right x1
- 14** Support Board x2

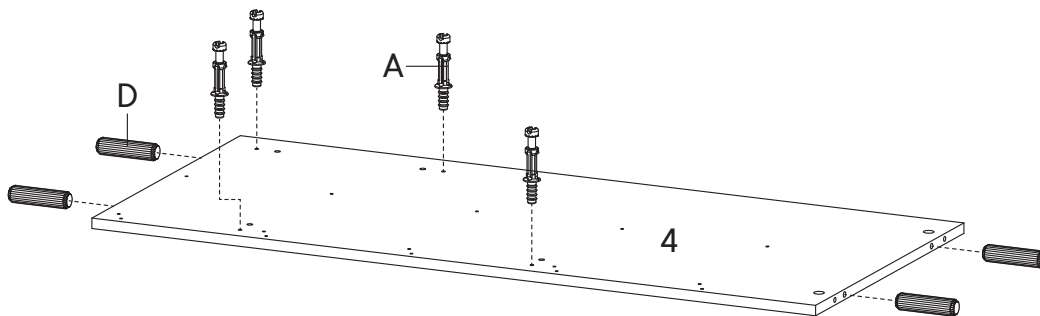
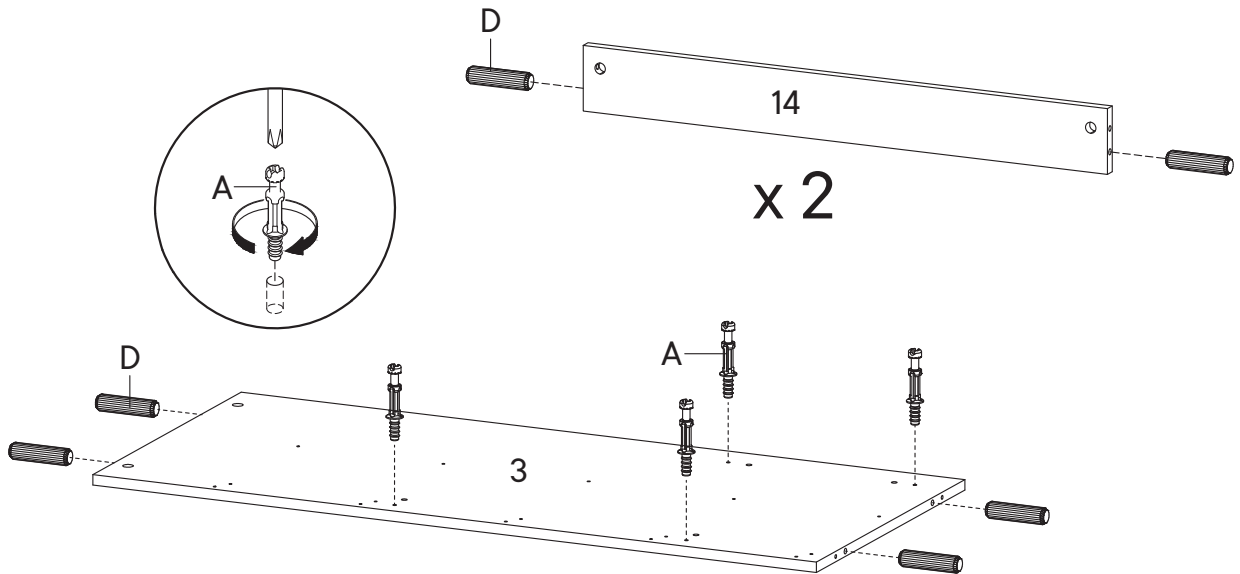
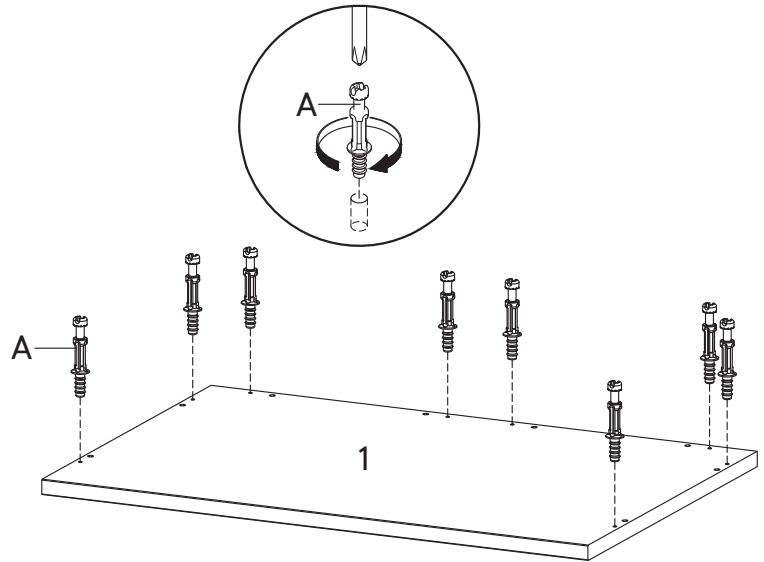

## Step 6

### HARDWARE

**P** Screw M 6 x 10.5 mm x30

**RM35A** Drawer Runner x5

### COMPONENTS

**3** Side Board Left x1

**4** Side Board Right x1

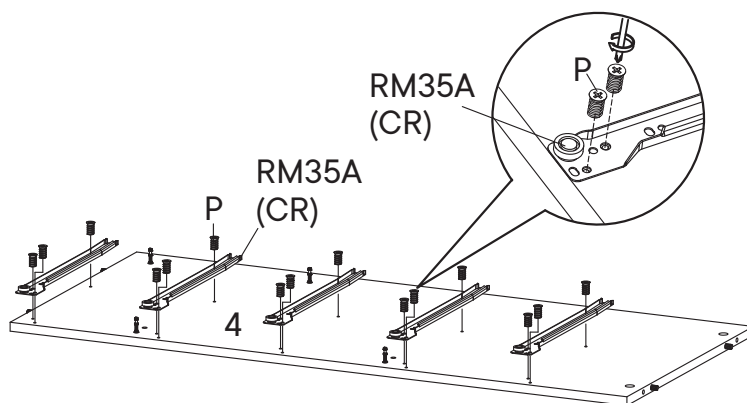
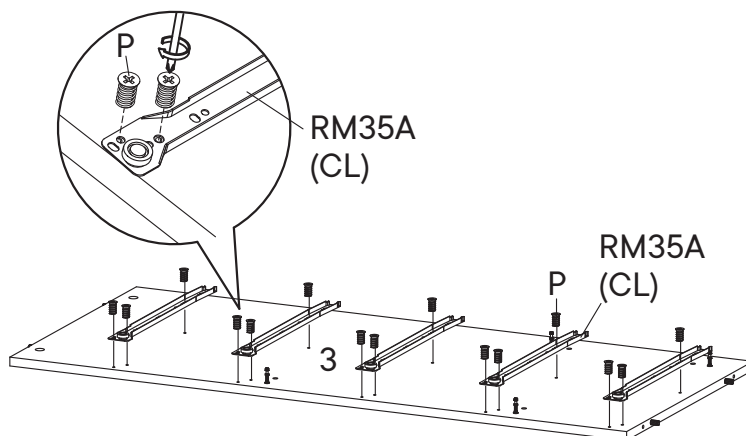
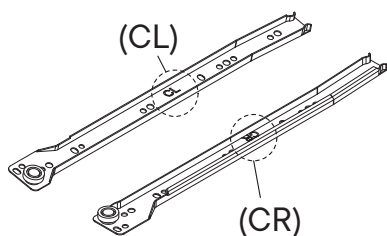

## Step 7

### HARDWARE

**D** Wood Dowel Ø8 x 30 mm x4

### COMPONENTS

**15** Counter Weight Board x1

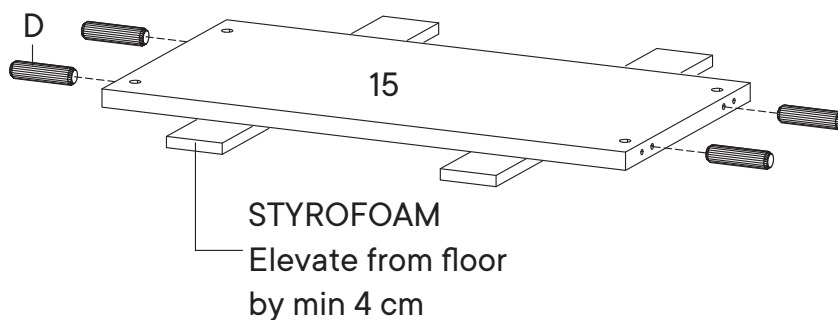

# Step 8

## HARDWARE

**D** Wood Dowel Ø8 x 30 mm x14

## COMPONENTS

**16** Back Board x4

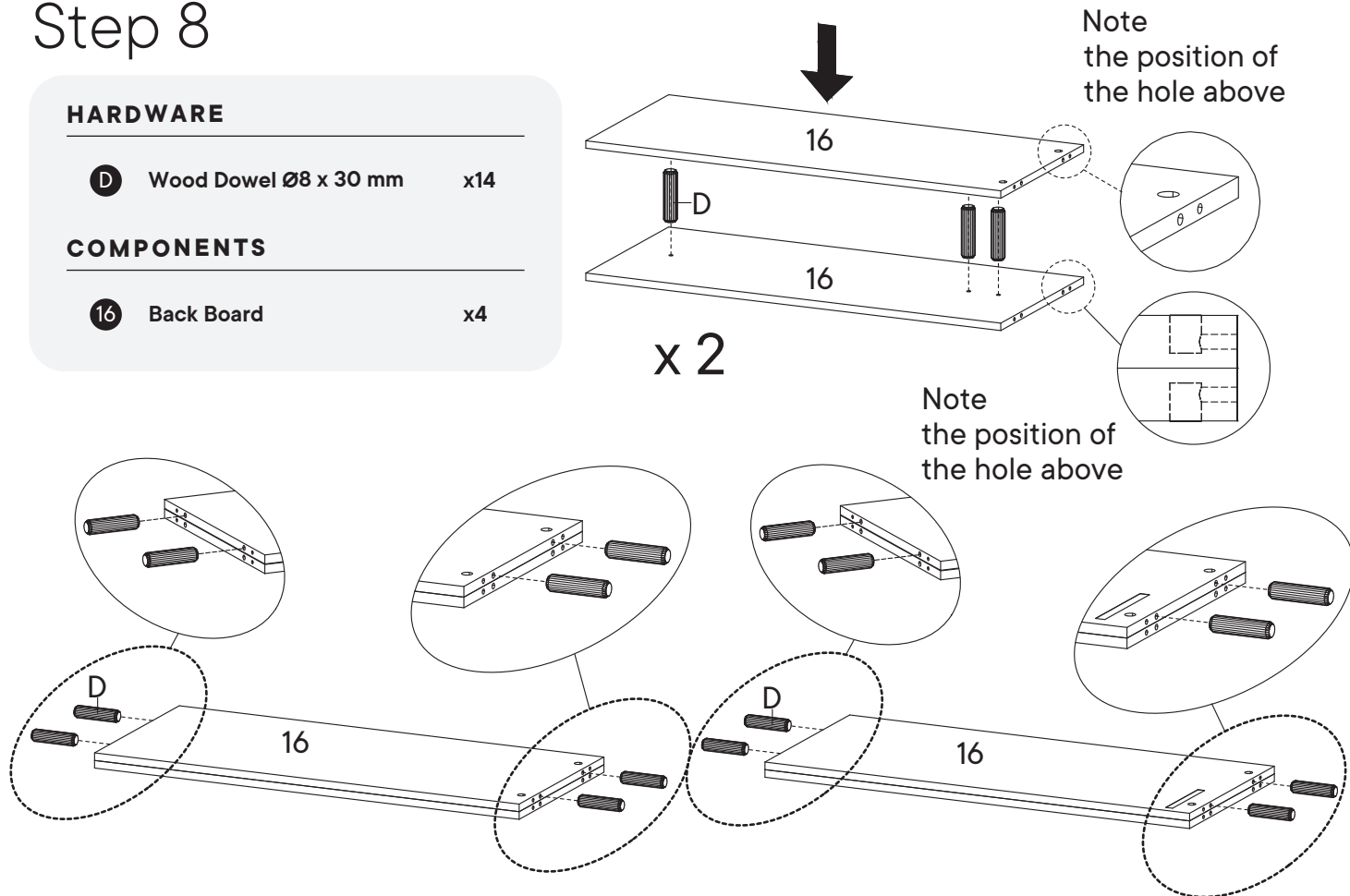

# Step 9

## HARDWARE

**B** Cam Lock Ø15 mm x4

## COMPONENTS

**3** Side Board Left x1

**14** Support Board x2

**15** Counter Weight Board x1

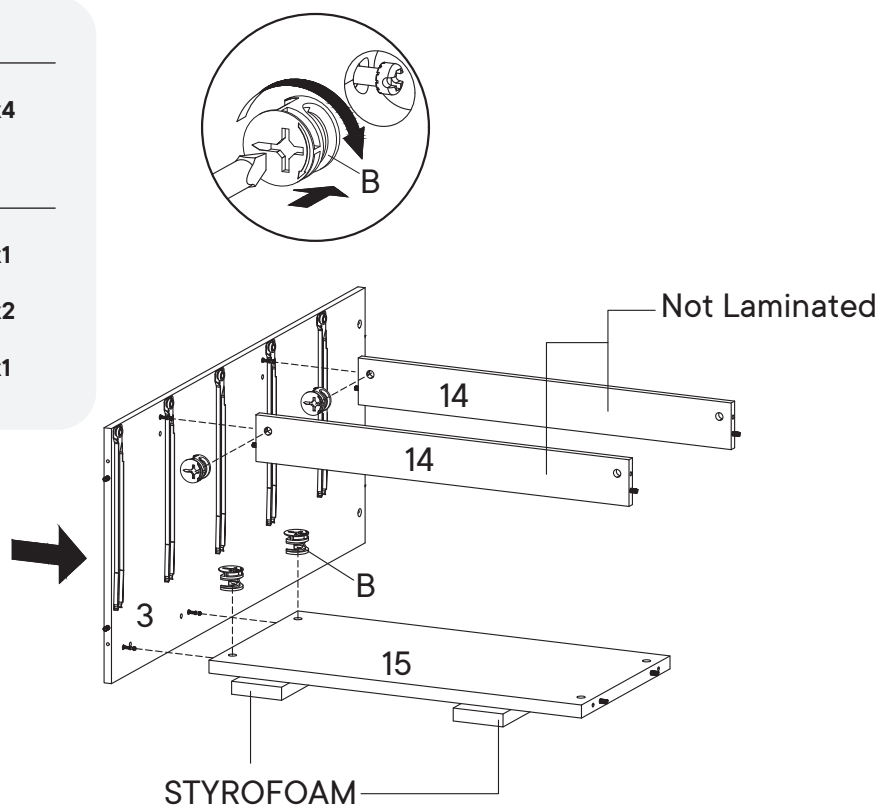

# Step 10

## HARDWARE

**B** Cam Lock Ø15 mm x4

## COMPONENTS

**4** Side Board Right x1

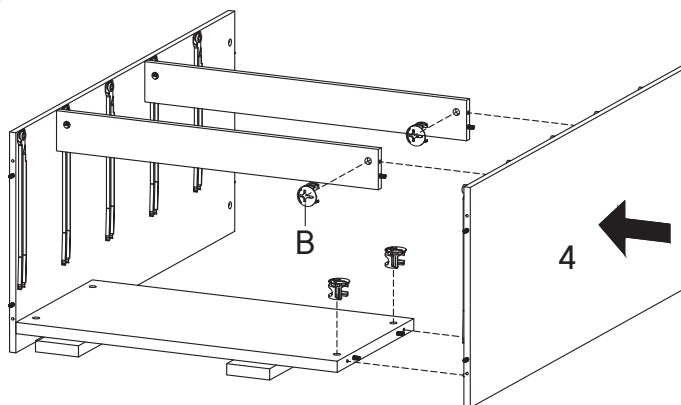
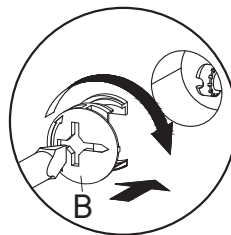

# Step 11

## HARDWARE

**B** Cam Lock Ø15 mm x4

## COMPONENTS

**1** Top Board x1

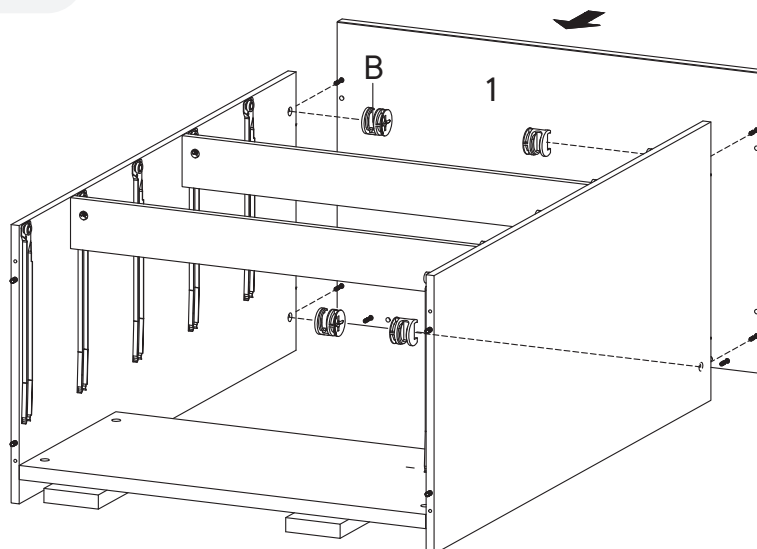
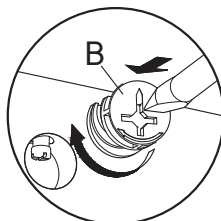

## Step 12

### HARDWARE

**B** Cam Lock Ø15 mm x4

### COMPONENTS

**16** Back Board x4

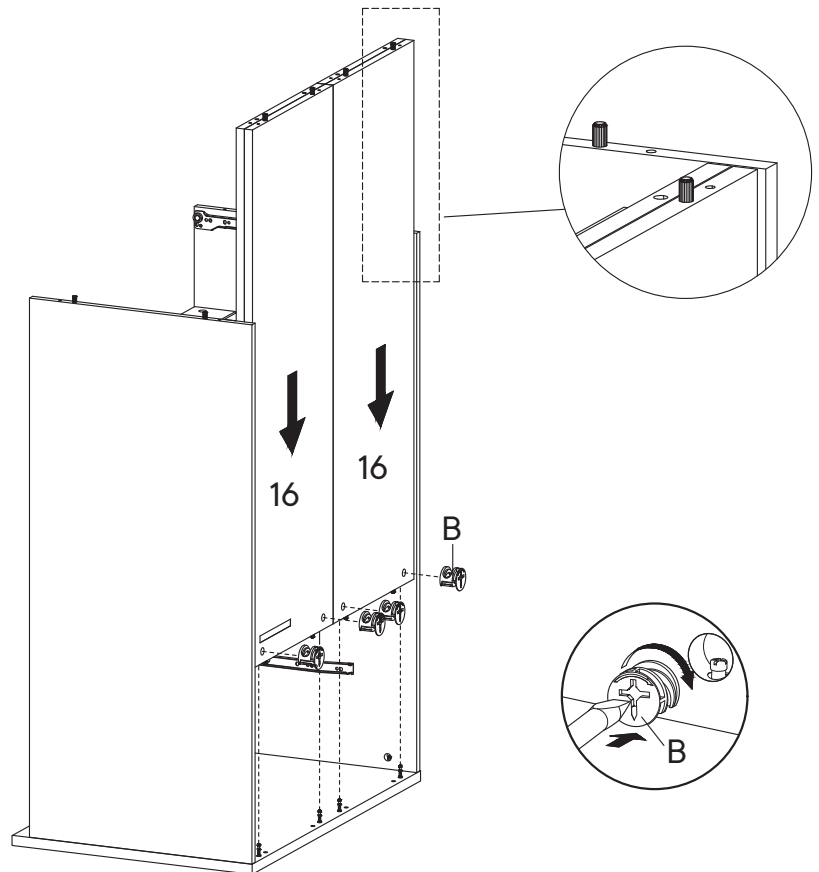

## Step 13

### HARDWARE

**H** Screw M 7 x 50 mm x8

**I** Allen Key x1

### COMPONENTS

**2** Bottom Board x1

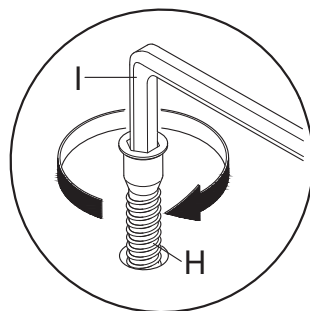
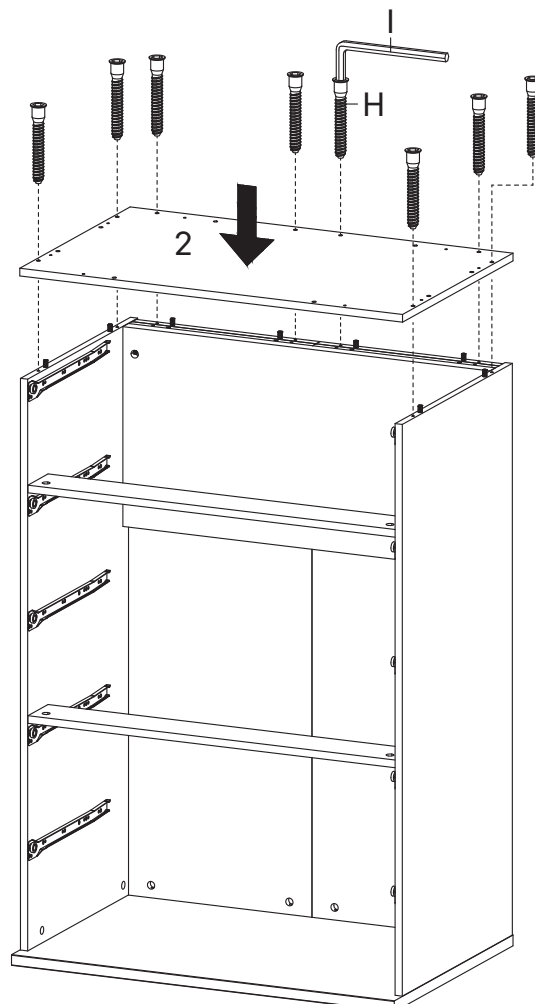

# Step 14

## HARDWARE

- A** Cam Bolt  $\varnothing 6 \times 35$  mm x8

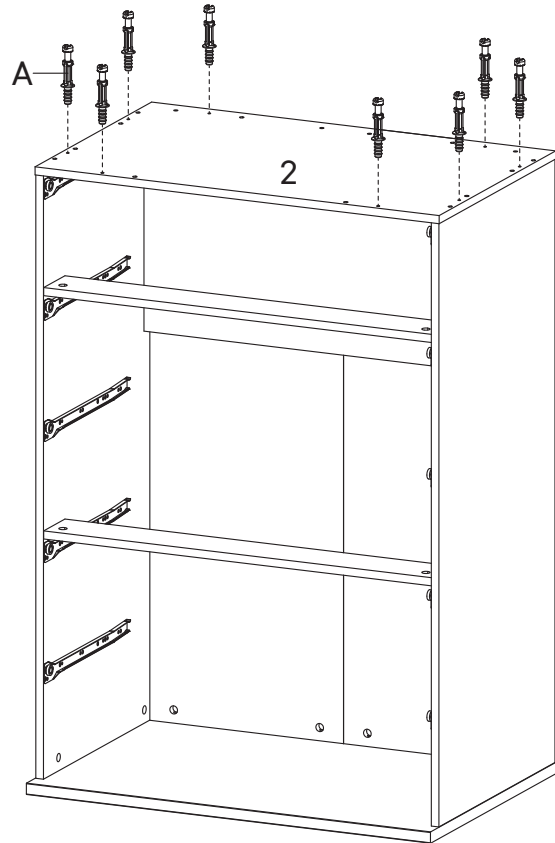
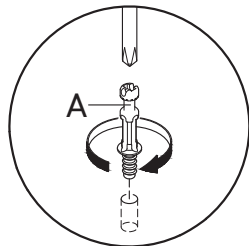

# Step 15

## HARDWARE

- A** Cam Bolt  $\varnothing 6 \times 35$  mm x4

- D** Wood Dowel  $\varnothing 8 \times 30$  mm x4

## COMPONENTS

- 5** Assembly Leg x2

- 6** Bottom Skirt x2

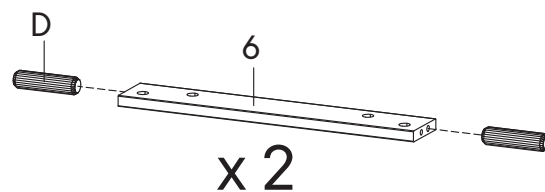
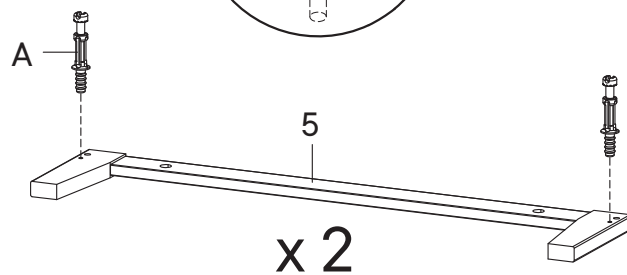
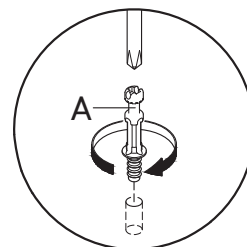

## Step 16

### HARDWARE

**B** Cam Lock Ø15 mm x4

### COMPONENTS

**5** Assembly Leg x2

**6** Bottom Skirt x2

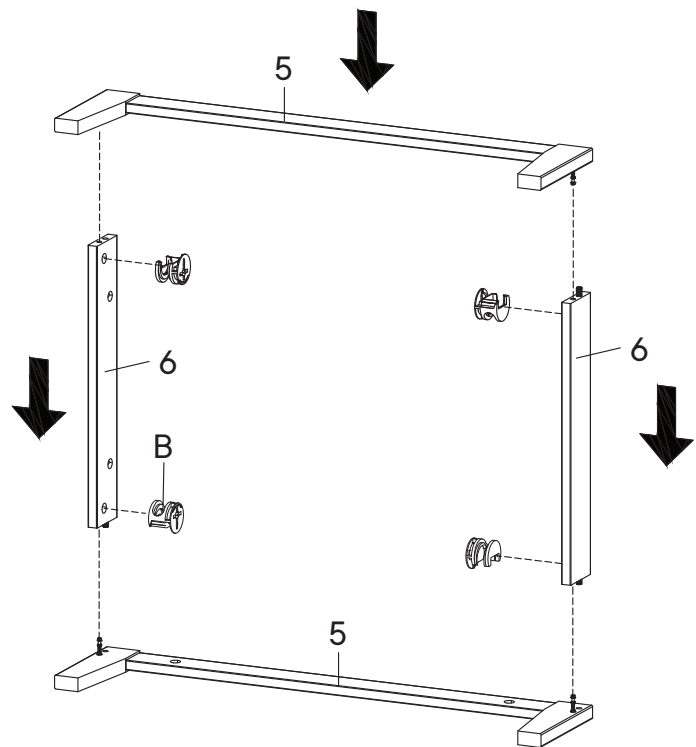
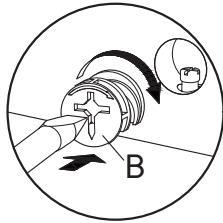

## Step 17

### HARDWARE

**D** Wood Dowel Ø8 x 30 mm x8

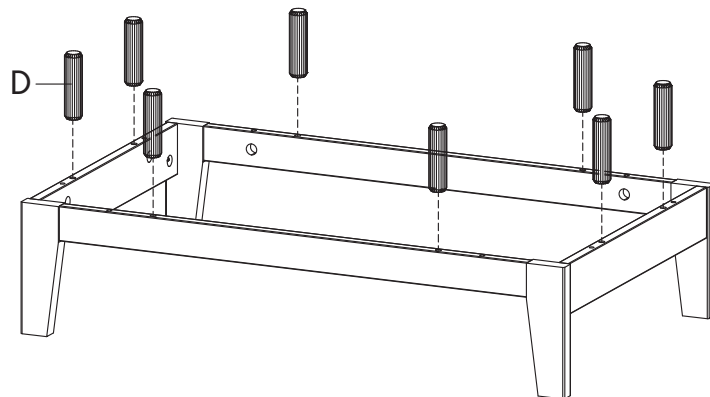

# Step 18

## HARDWARE

- B** Cam Lock Ø15 mm x8
- N** Floor Protector x4

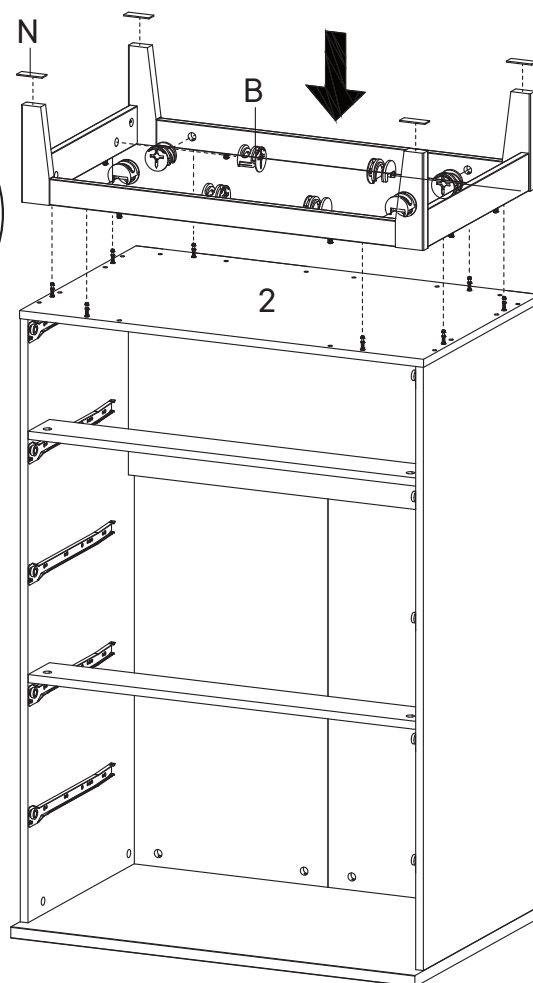
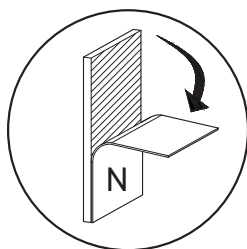
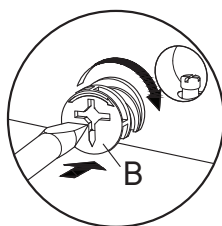

# Step 19

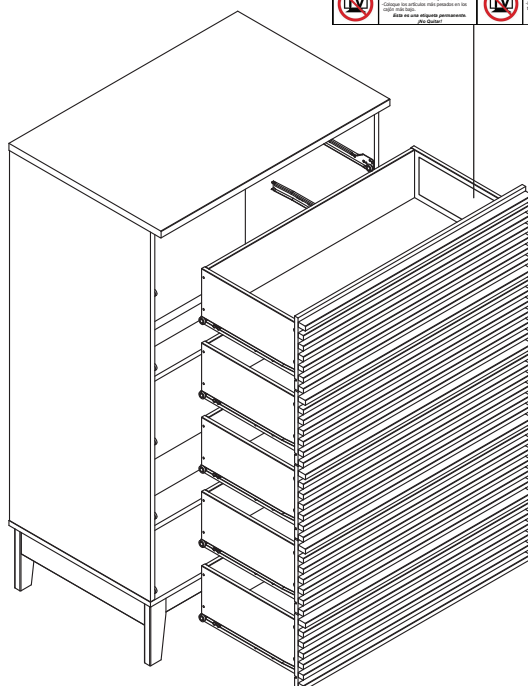
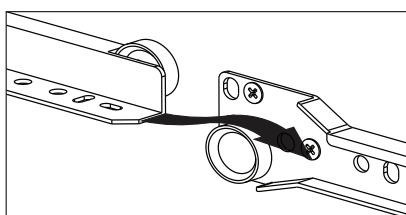

ADVERTENCIA	ATTENTION	WARNING
No utilizar este producto cerca de fuego. Para reducir el riesgo de incendio, no utilizar este producto cerca de estufas, velas, veladores, etc.	Do not use this product near fire. To reduce the risk of fire, do not use this product near stoves, candles, heaters, etc.	Children must not play with this product. To reduce the risk of fire, do not use this product near stoves, candles, heaters, etc.
No utilizar este producto con objetos afilados. Evitar lesiones.	Do not use this product with sharp objects. Avoid injury.	Do not use this product with sharp objects. Avoid injury.
No utilizar este producto con cargas excesivas. Evitar lesiones.	Do not use this product with excessive loads. Avoid injury.	Do not use this product with excessive loads. Avoid injury.
No utilizar este producto con líquidos. Evitar lesiones.	Do not use this product with liquids. Avoid injury.	Do not use this product with liquids. Avoid injury.
No utilizar este producto con niños. Evitar lesiones.	Do not use this product with children. Avoid injury.	Do not use this product with children. Avoid injury.

# Great job!

Chest Of Drawers assembly is complete.

## ♥ CARING FOR YOUR ITEM

Indoor use only.

Not contract grade.

Clean using a non-abrasive cloth and a mild cleaner.

Never use harsh chemicals, as they could damage the finish or integrity of the item.

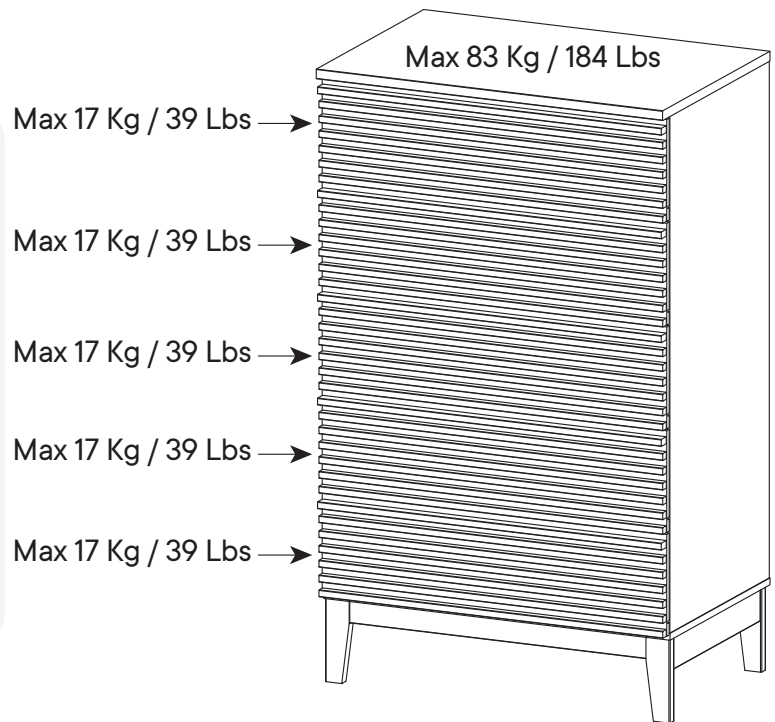

CONNECT WITH US!   

Tag us @modway\_furniture and #modway for a chance to be featured.

## TIPPING RESTRAINTS KIT INSTALLATION GUIDANCE

Different wall materials require unique wall fasteners.

The wall plugs (AA2) and screws (AA3) are designed for fixing to concrete walls only.

Please consult your local hardware store to ensure you are using the correct hardware for you wall type.

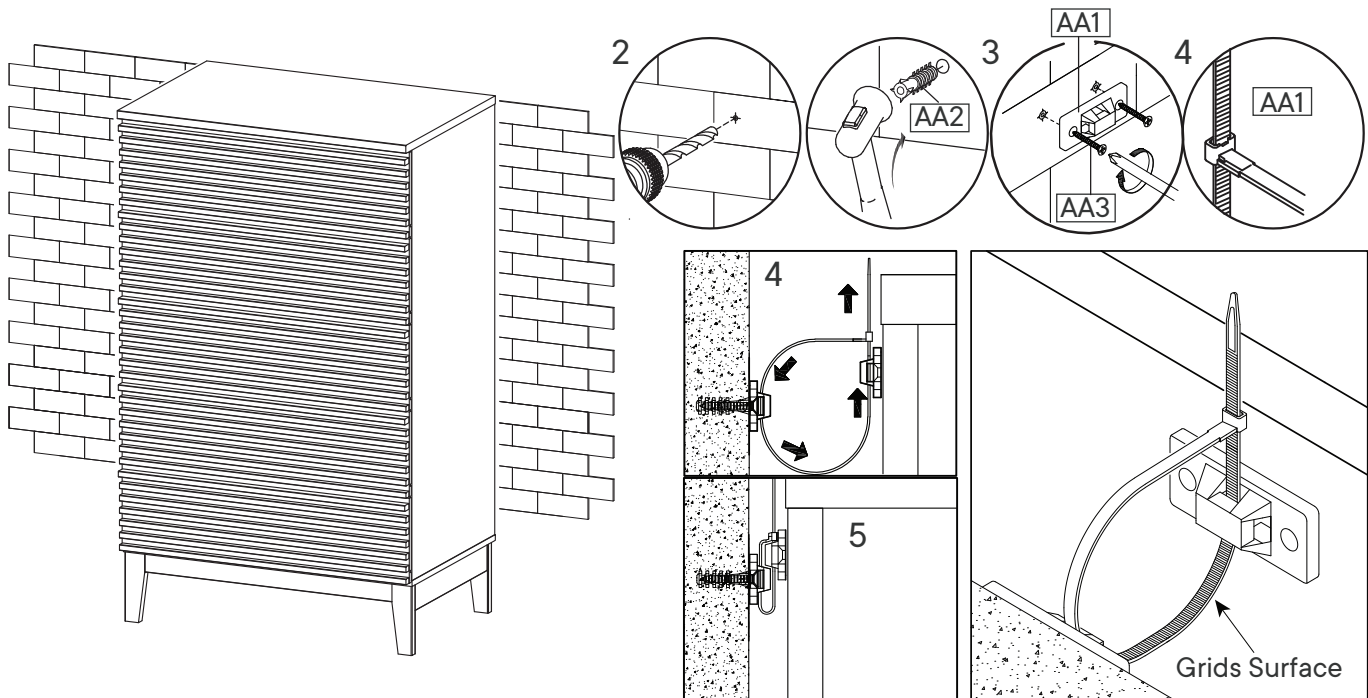
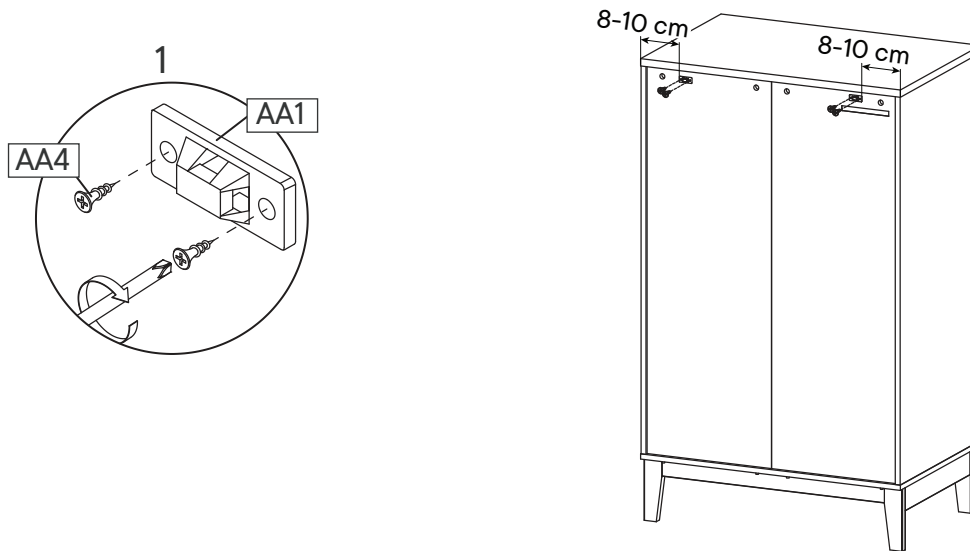
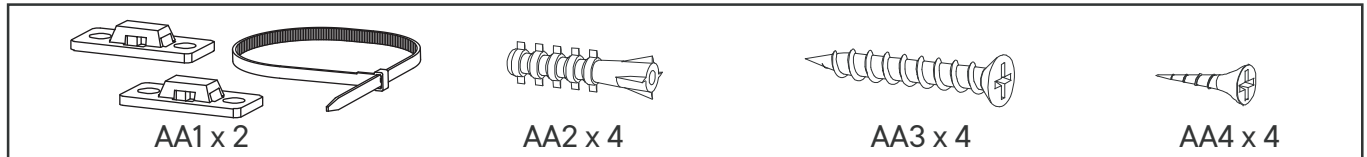

### Installation Instructions :

1. Attach bracket (AA1) securely to the back top of the furniture using screw (AA4) provided. Allow 8 - 10 cm from each side.
2. Please make a hole for wall plugs position on the wall and minimum 15 mm below bracket secured to the back of unit. Attach the wall plugs (AA2).
3. Install the other bracket (AA1) on the wall over wall plugs (AA2), secure with screw (AA3). Place furniture into position so both brackets (AA1) are aligned.
4. Lace the end of the restraints strap through the larger hole in each bracket. Ensure the restraints strap with grids surface facing the inner loops. Bring both ends together and slide the flat end through the locking end and draw it through until all slack is removed.
5. Make sure that the strap is securely laced & locked.