

**E<sup>TM</sup>**  
**D**

**ELLEN DEGENERES**

[BATH.EDBYELLEN.COM](http://BATH.EDBYELLEN.COM)

## INTRODUCTION WELCOME

ED is Ellen DeGeneres' iconic style, values and personality shared through collections of beautifully designed, high-quality products for home, pets and people. All ED merchandise design and materials are approved by Ellen, ensuring it maintains her standards and upholds her promise to make each item feel like a personal connection between herself and consumers around the world.

# 24-IN FLOOR CABINET

ITEM #  
3629222; 3629223  
MODEL #  
1480FC-24-201; 1480FC-24-283

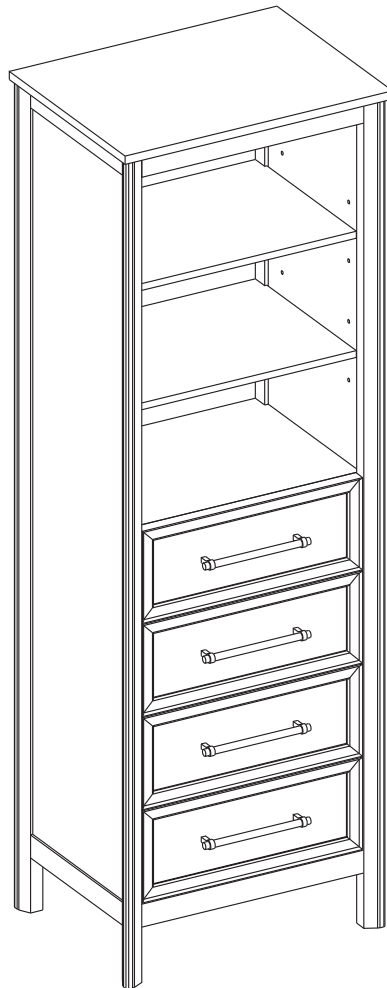

MODEL NUMBER	DESCRIPTION
1480FC-24-201	24" White Finish Floor Cabinet
1480FC-24-283	24" Coastal Oak Finish Floor Cabinet

## ATTACH YOUR RECEIPT HERE

Serial Number \_\_\_\_\_ Purchase Date \_\_\_\_\_

---

**Questions, problems, missing parts?** Before returning to your retailer, call our customer service department at 1-855-571-1044, 9 a.m. - 5 p.m., EST, Monday - Friday.

## TABLE OF CONTENTS

---

Package Contents.....	5
Hardware Contents.....	5
Safety Instructions.....	5
Preparation .....	6
Assembly or Installation Instructions .....	6
Care and Maintenance .....	10
Warranty .....	10
Replacement Parts List .....	11

## PACKAGE CONTENTS

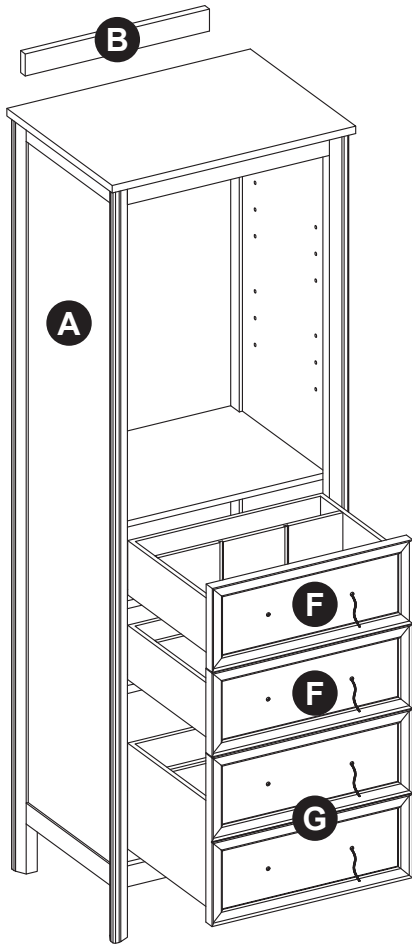

PART	DESCRIPTION	QUANTITY
A	Cabinet	1
B	Wall Mounting Spacer Bar (preassembled to Cabinet (A))	1
C	Shelf	2
D	Drawer Divider	4
E	Drawer box	2
F	Upper Drawer (preassembled to Cabinet (A))	2
G	Lower Drawer (preassembled to Cabinet (A))	1

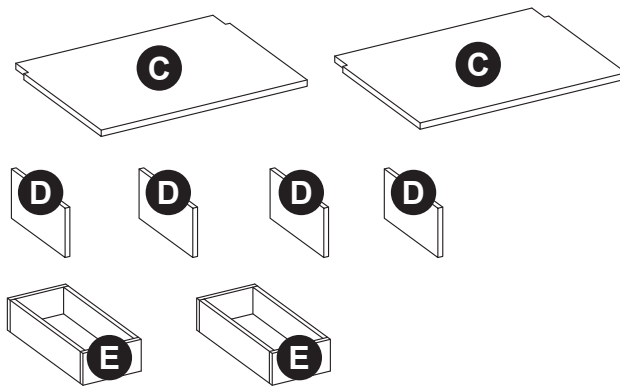

## HARDWARE CONTENTS (NOT SHOWN ACTUAL SIZE)

AA



Touch Up Pen  
Qty. 1

BB

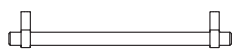

Handle (2 Options)  
Brushed Nickel (Qty. 4)  
Champagne Brass (Qty. 4)

CC



Shelf Pin  
Qty. 8

## SAFETY INSTRUCTIONS

Please read and understand this entire manual before attempting to assemble, operate or install the product.

### WARNING

- There are several assembly steps, including unpacking, that require two adults.

### CAUTION

- Before installation, carefully use scissors or utility knife to cut and unwrap all parts. Make sure you DO NOT discard the hardware.
- Follow these instructions closely, take your time, and use care while assembling this floor cabinet.

**KEEP THESE INSTRUCTIONS FOR FUTURE REFERENCE.**

## PREPARATION

Before beginning assembly of product, make sure all parts are present. Compare parts with package contents list and hardware contents list. If any part is missing or damaged, do not attempt to assemble the product.

**Estimated Installation Time:** 30 minutes.

Tools Required for Installation (not included): Phillips screwdriver, utility knife or scissors, power drill with drill bit.

Helpful Tools (not included): Measuring tape, level

## INSTALLATION INSTRUCTIONS

**Note:** This floor cabinet comes with two different drawer handle options.

1. One set of handles (BB) are attached to the inside of the drawers, and the other set is located in a hardware pack. Use the attached string to open the drawers initially. Unscrew the handles (BB) and attach your preferred handles to the outside of the drawers, as illustrated in the diagram.

### Hardware Used

**BB** Handle  x 4

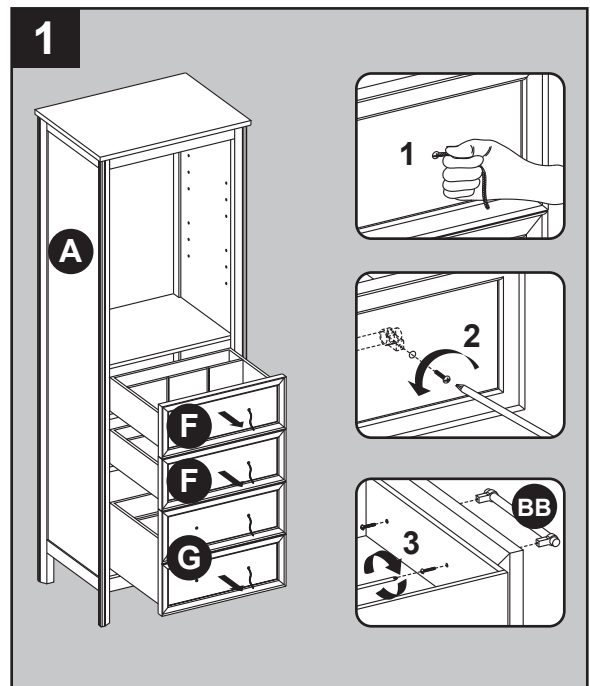

2. If the location you will be installing the floor cabinet has baseboard molding, proceed to Step 3.

If the location you will be installing the floor cabinet does not have baseboard molding, unscrew and remove the wall mounting spacer bar (B) from the back of the cabinet before proceeding to Step 3.

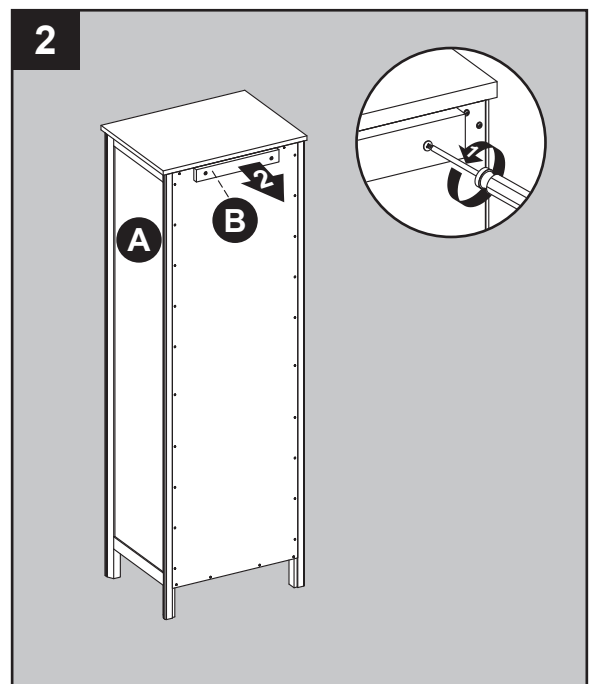

## INSTALLATION INSTRUCTIONS

3. Clean area where the cabinet (A) will be permanently located prior to beginning installation, ensuring the cabinet (A) will not interfere with any plumbing or electrical lines once mounted.

Locate wall studs and mark locations. With the help of another adult, place completed cabinet assembly in its final location. Adjust the height of the cabinet (A) by twisting the adjustable leveler foot pins on the bottom of each leg. Twist clockwise to decrease height or twist counter-clockwise to increase cabinet height. Using hardware appropriate for your wall type such as cabinet screw or toggle bolt (not included), secure cabinet (A) to preferably two wall studs anywhere through the cabinet mounting bar. Be careful not to disturb any electrical or water lines that may be concealed in the wall.

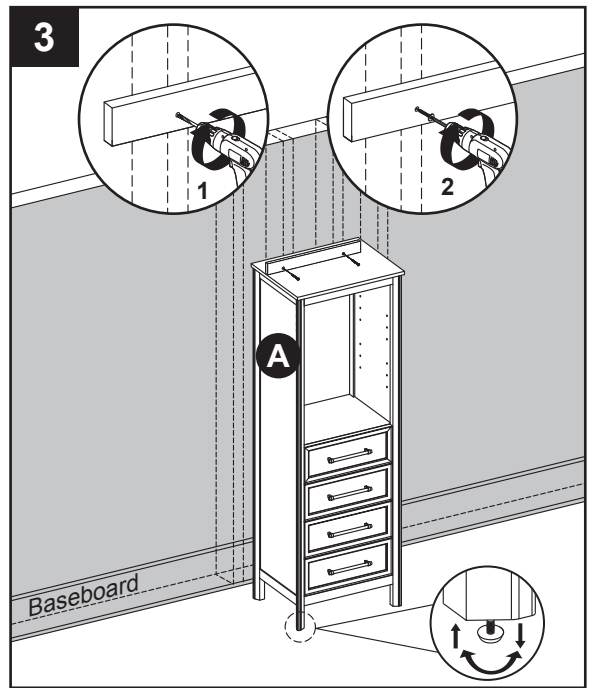

4. Screw shelf pins (CC) hand tight into the threaded holes of cabinet (A). Place shelf (C) on top of shelf pins (CC).

Repeat for the remaining shelf (C).

### Hardware Used



Shelf Pin



x 8

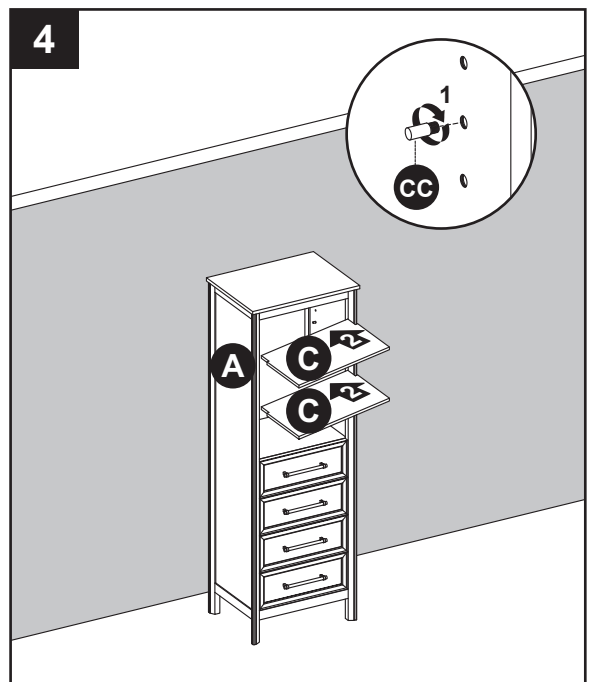

## INSTALLATION INSTRUCTIONS

5. Insert two drawer dividers (D) into the notch of upper drawers (F) inside. Place the two drawer boxes (E) flat in the lower drawer (G).

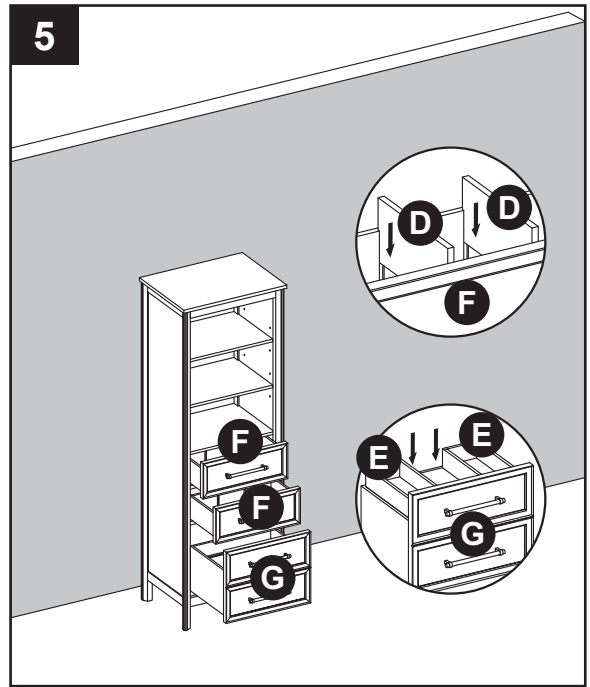

6. As shown in the diagram, fully extend the drawer and locate the plastic levers on the metal glide tracks. Push the left-side and right-side levers at the same time to disengage the drawer from the drawer glides. Gently lift the drawer up to remove it from cabinet (A).

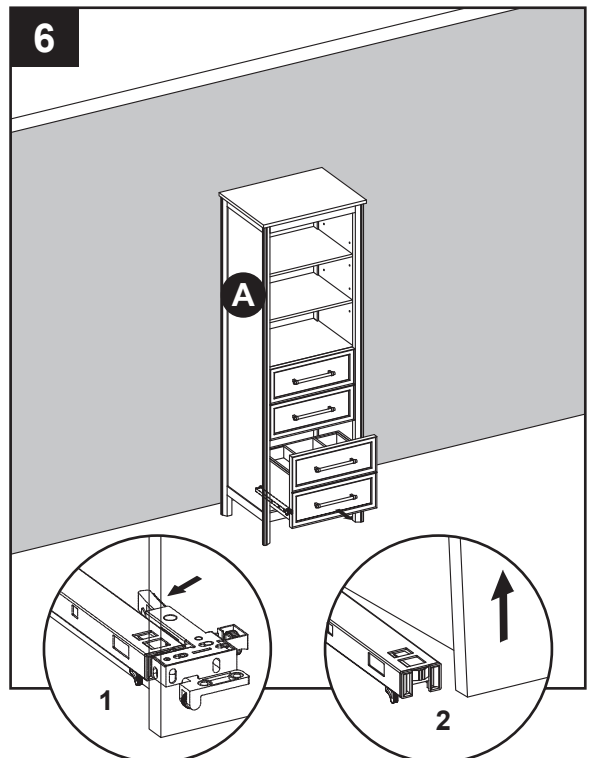

## INSTALLATION INSTRUCTIONS

7. To reinstall drawer(s) into cabinet (A), fully extend metal glide tracks. Gently lower and slide drawer box into rear glide catch. Next, lower drawer box down to completely rest on extended glides. Then, push plastic levers to lock the drawer box in place.

**Note:** Drawer box alignment can be adjusted, if necessary. As shown in the diagram, spin the adjustment wheel to the left to raise the drawer box, or to the right to lower the drawer box. The left and right-side glide heights can also be adjusted independently in order to find the drawers best alignment position.

### CAUTION

**DO NOT** force drawer or damage to glide(s) may occur. If drawer does not slide in with ease, remove and try again from the start.

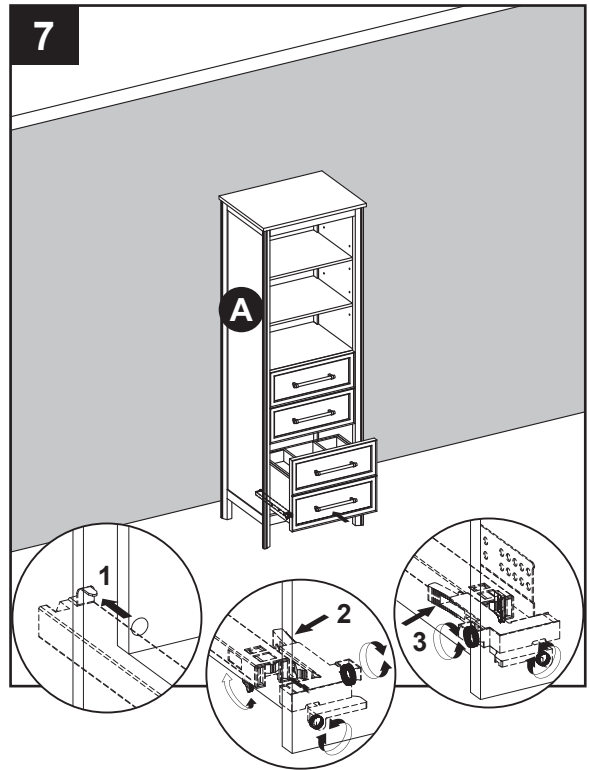

## **CARE AND MAINTENANCE**

---

- Dust the floor cabinet regularly with a soft, non-lint producing cloth or household dusting product.
- You can clean the floor cabinet with a gentle, non-abrasive household cleaner.
- Make sure to dry the wood immediately with a soft cloth or towel.
- Tips for using touch-up pen (AA): For scratches, stroke in direction of scratch. Rub off excess colorant promptly with a soft cloth.

## **WARRANTY**

---

The manufacturer warrants this item against defects in materials and workmanship for a period of one (1) year from the date of original retail purchase. This warranty applies only to the original purchaser. This warranty does not apply to any damage on the product by accident, misuse, or modified, improper installation or by affixing accessories not produced by the manufacturer. The manufacturer is not accountable whatsoever for product installation during the warranty period. There is no further expressed warranty. The manufacturer shall not be legally responsible for incidental, consequential or special damages arising at or in connection with product use or performance except as may otherwise be accorded by law. The manufacturer disclaims any and all implied warranties.

## REPLACEMENT PARTS LIST FOR 1480FC-24-201

For replacement parts, call our customer service department at 1-855-571-1044, 9 a.m. - 5 p.m., EST, Monday - Friday.

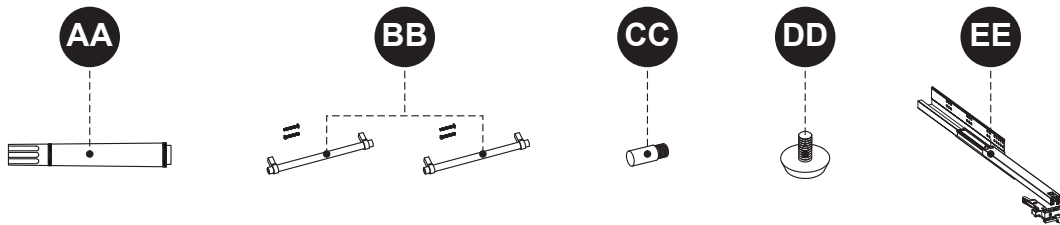
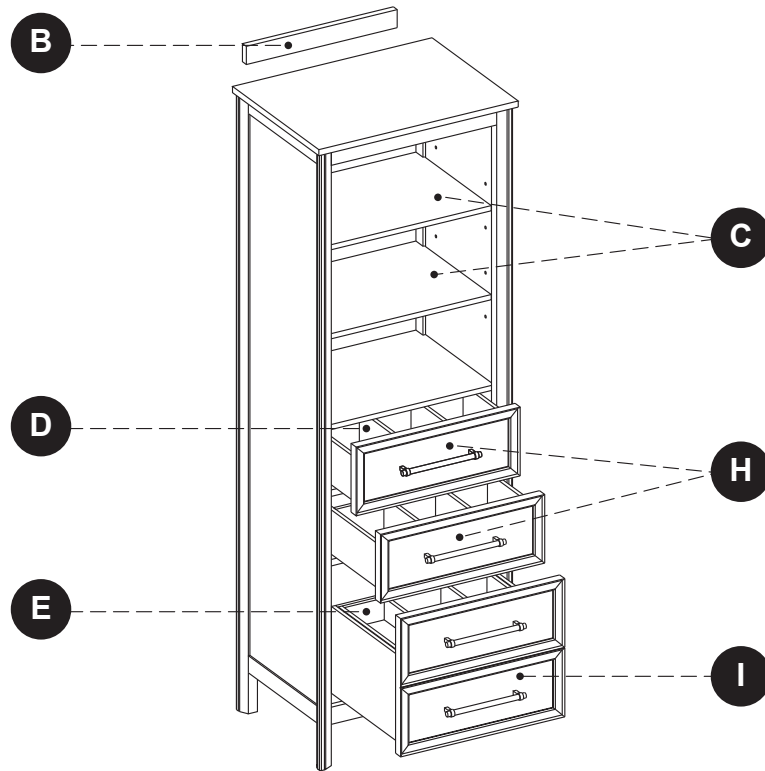

PART	DESCRIPTION	PART #
B	Wall Mounting Spacer Bar	FC-WALL MOUNTING BAR-201
C	Shelf	1480FC-24-201-SHELF
D	Drawer Divider	1480FC-24-201-DIVIDER
E	Drawer Box	1480FC-24-201-DRAWER BOX
H	Upper Drawer Front	1480FC-24-201- TOP DRAWER FRONT
I	Lower Drawer Front	1480FC-24-201- BOTTOM DRAWER FRONT
AA	Touch-up Pen	OF-0010
BB	Handle-brushed nickel	1480-BN HARDWARE
	Handle-champagne brass	1480-CB HARDWARE
CC	Shelf Pin	PU17-SP-002
DD	Leveler	T-1007
EE	14-IN Glide Track Set	SH-ABC-14IN-3A

## REPLACEMENT PARTS LIST FOR 1480FC-24-283

For replacement parts, call our customer service department at 1-855-571-1044, 9 a.m. - 5 p.m., EST, Monday - Friday.

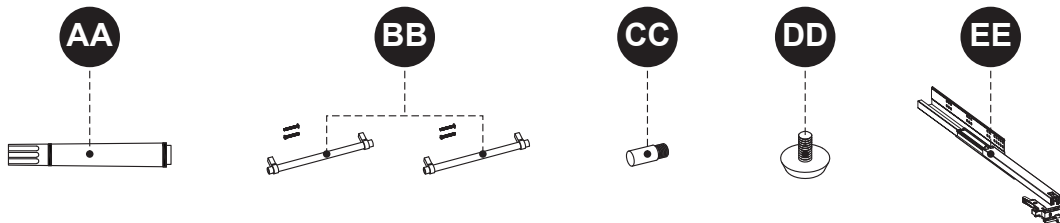
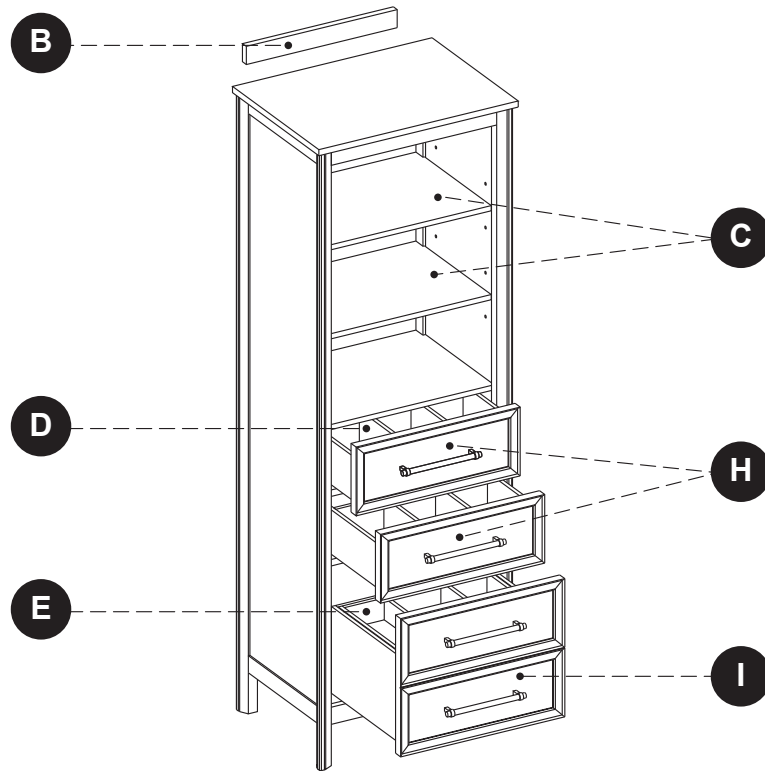

PART	DESCRIPTION	PART #
B	Wall Mounting Spacer Bar	FC-WALL MOUNTING BAR-283
C	Shelf	1480FC-24-283-SHELF
D	Drawer Divider	1480FC-24-283-DIVIDER
E	Drawer Box	1480FC-24-283-DRAWER BOX
H	Upper Drawer Front	1480FC-24-283- TOP DRAWER FRONT
I	Lower Drawer Front	1480FC-24-283- BOTTOM DRAWER FRONT
AA	Touch-up Pen	M-1108
BB	Handle-brushed nickel	1480-BN HARDWARE
	Handle-champagne brass	1480-CB HARDWARE
CC	Shelf Pin	PU17-SP-002
DD	Leveler	T-1007
EE	14-IN Glide Track Set	SH-ABC-14IN-3A



