

Thank you for purchasing the **MOD- 5349/5350/5351/5352/ 5616/5625/5628/5629 FULL / QUEEN BED FRAME**

Before you start, here are some helpful advice:

1. We suggest that you spend a short time reading through this leaflet and then follow the simple step-by-step instructions.
2. Owing to the size and weight of the bed frame, we recommend that it is assembled by two adults, on a carpeted or padded area, in the room that it is intended for. Approximate assembly time: 45 minutes.
3. Please do not use any tools other than those provided or recommended in these instructions.
4. Please do not throw away any of the packaging or the instruction until you have checked all the components and hardware and the furniture is fully assembled. Please ensure that the packaging is disposed of in a safe environmentally friendly way.
5. Assemble all components loosely until advised to tighten. Depending on use, it may be necessary to tighten the components from time to time, so please save the tools that have been provided.
6. Please keep all fitting out of reach of children.

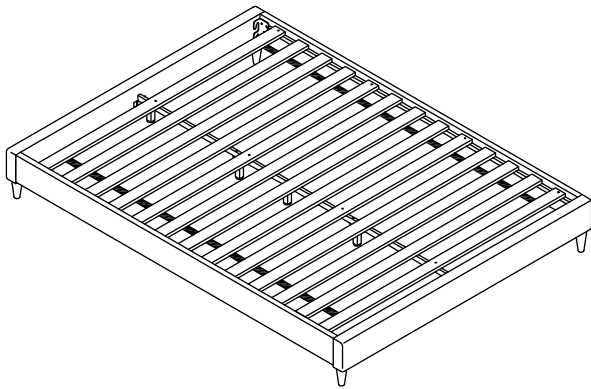

Hardware list:

- | | | | |
|---|--|-----------------|-----|
| A | | Bolt M8 x 20mm | x8 |
| B | | Screw M4 x 32mm | x14 |
| C | | M5 Allen Key | x1 |

PHILLIPS HEAD SCREW DRIVER
NOT PROVIDED

Components:

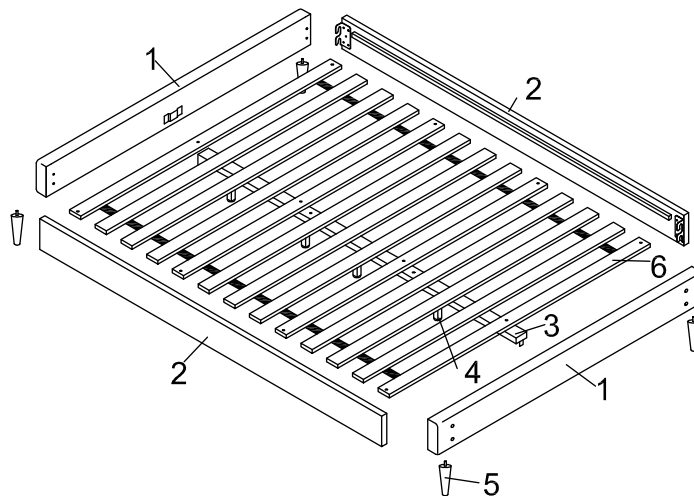

- | | | | | | |
|----------------|----|--------------|----|---------------|-----|
| 1 Short Board | x2 | 2 Long Board | x2 | 3 Center Rail | x1 |
| 4 Support Legs | x4 | 5 Legs | x4 | 6 Roll Slats | x13 |
- (Round leg or square leg)

STEP 1

Secure the 2 pieces of **Wooden Leg (5)** to the **Short Board (1)** as shown. Repeat the same steps for the remaining 1 piece of **Short Board (1)**. Tighten the **Leg (5)** clockwise until secure.

Attention: If it is square leg, please make sure the leg direction is level with frame.

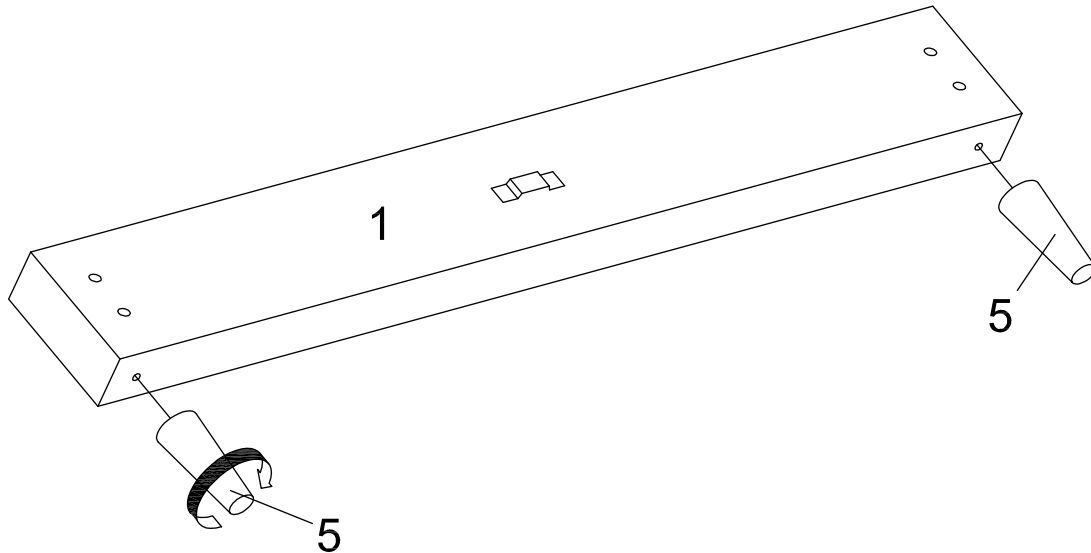

STEP 2

Place 1 piece of **Long Board (2)** to the assembled 2 pieces **Short Board (1)** by two adults.

Attach them by using 4 pieces of **Bolt (A)** as shown.

Use **Allen Wrench (C)** to tighten the **Bolts (A)** clockwise until secure.

Repeat the same steps for the remaining 1 piece of **Long Board (2)**.

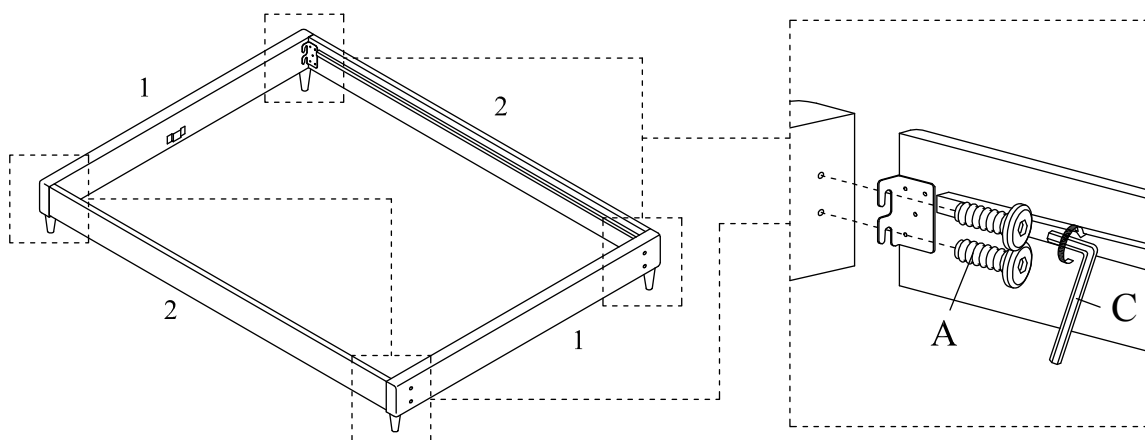

A x 8	C x 1

Hardware & Tool required

STEP 3

Secure 4 pieces of **Support Leg (4)** to the **Center Rail (3)** with pre-set T-nut as shown. Tighten the **Support Leg (4)** clockwise until secure.

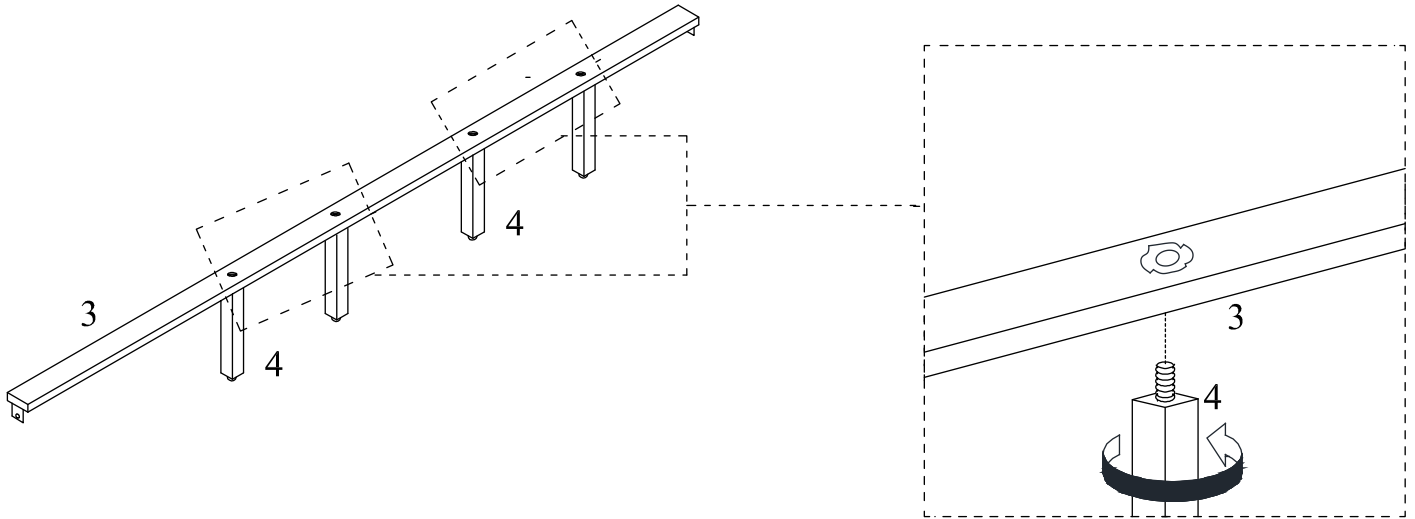

STEP 4

Insert **Center Rail (3)** to the bracket (provided) on **Short Board (1)** and then secure with 1 piece **Screw (B)** per each end. Tighten the **Screw (B)** with Phillips Head Screw Driver (not provided).

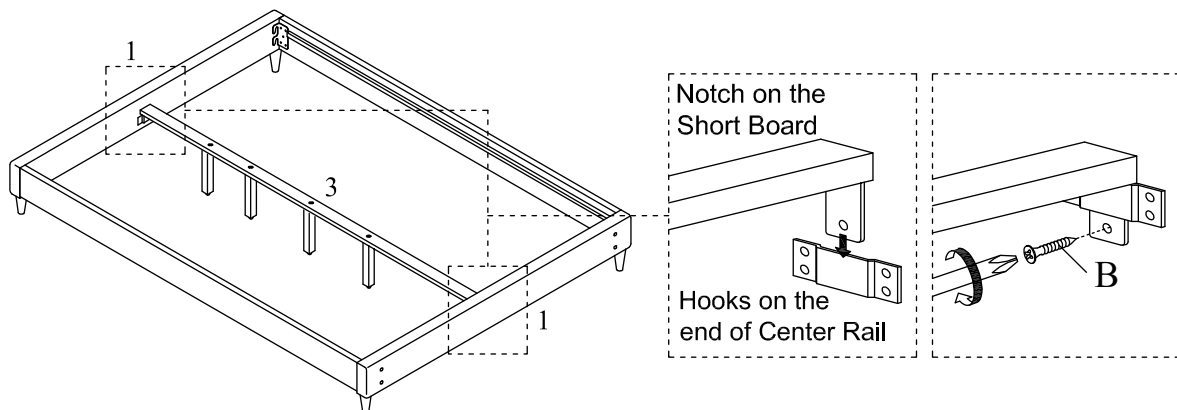

B x 2	Phillips Head Screw Driver (not provided)

Hardware & Tool required

STEP 5

Place the **Roll Slats (6)** to the **Long Board (2)** as shown.

Secure 4 pieces of **Roll Slats (6)** which have countersink holes on each end into the **Long Board (2)** by using 8 pieces of **Screw (B)** as shown.

Tighten the **Screws (B)** with Phillips Head Screw Driver (not provided).

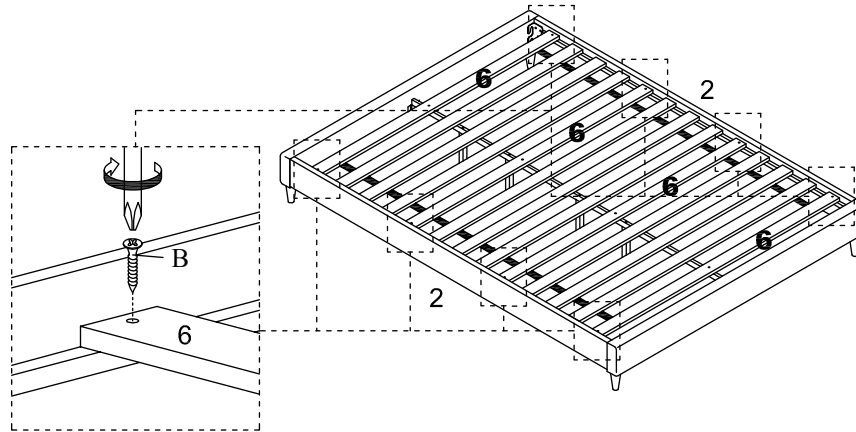

B x 8	Phillips Head Screw Driver (not provided)

Hardware & Tool required

STEP 6

Secure 4 pieces of **Screw (B)** into the **Slat (6)** on the top of **Center Rail (3)** as shown.

Tighten the **Screws (B)** with Phillips Head Screw Driver (not provided).

Attention: Please adjust the adjustable glide on the Support Leg (4) once the bed is unlevel.

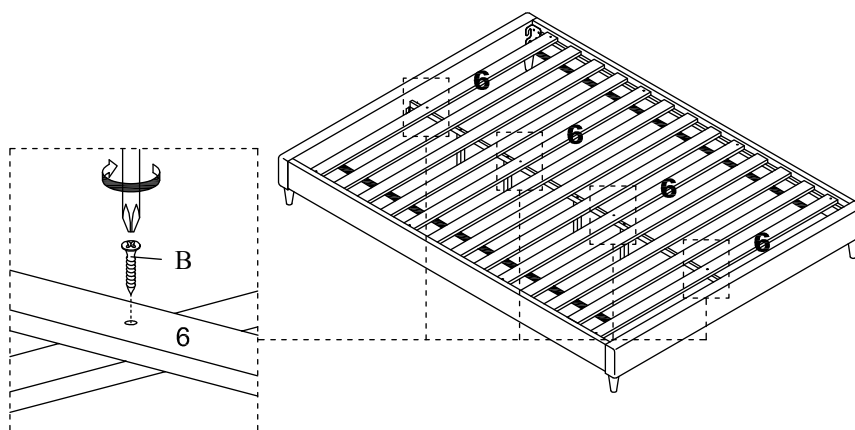

B x 4	Phillips Head Screw Driver (not provided)

Hardware & Tool required

Assembly is complete. The bed frame is ready to use now!

NOTE: Hardware may loosen over time. Periodically check that all connections are tight.

ASSEMBLY INSTRUCTIONS

Note: This is assembly instruction for MODWAY Full/Twin/Queen/King Bed Frame **MOD-5347/5348/5349/5350/5351/5352/5353/5354/5581/5582/5616/5625/5626/5627/5628/5629** to connect Headboard **MOD-5365/5366/5367/5368/5369/5370/5371/5372/5373/5374/5375/5376/5377/5378/5379/5380/5381/5382/5383/5384/5385/5386/5387/5388/5389/5390/5391/5392/5393/5394/5395/5396/5397/5398/5399/5400/5401/5402/5403/5404/5405/5406/5407/5408**.

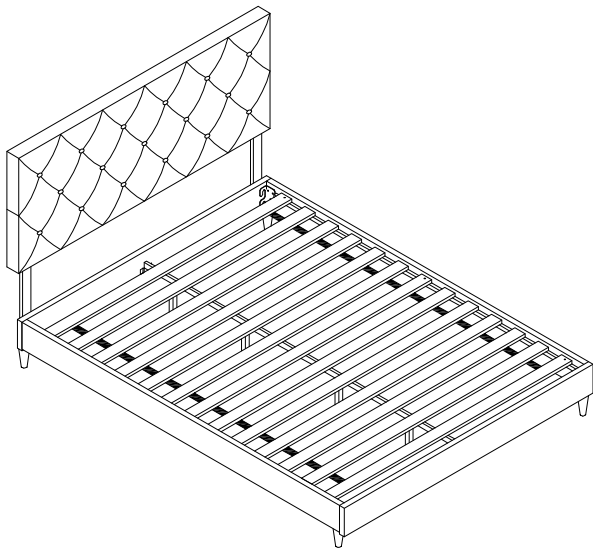

Hardware list:

A		Bolt M6 x 45mm	x4
B		Flat Washer M6	x4
C		Spring Washer M6	x4
D		M4 Allen Key	x1

Reminder: All the hardware packed in the Headboard you bought. Please use only the above hardware from Haedboard Hardware Package to assemble the Bed Frame and Headboard.

Component:

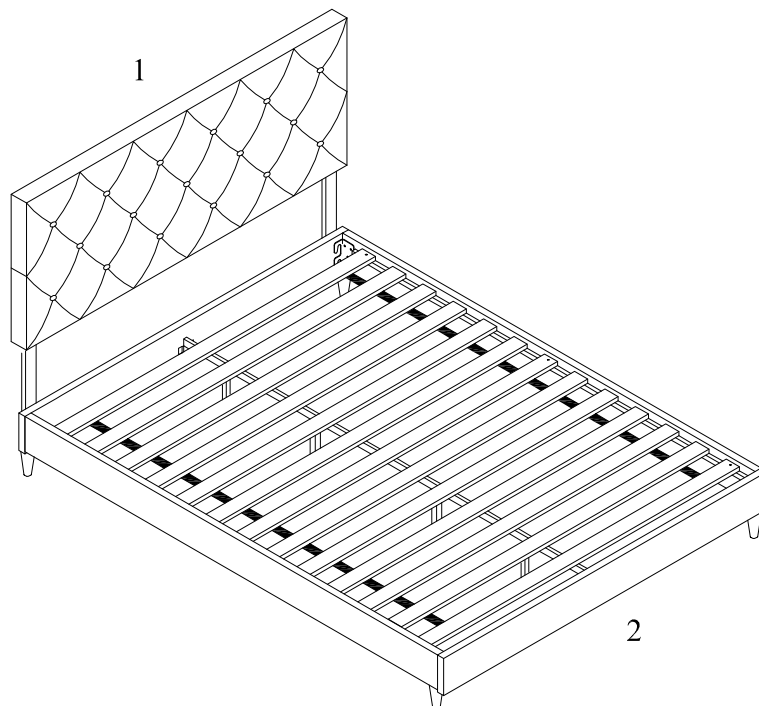

1) Headboard x1

2) Bed Frame x1

(Style may vary)

STEP 1

Line up the **Bed Frame (2)** board's pre-drilled holes to match those of the **Headboard (1)**.

Secure the **Headboard (1)** to the **Bed Frame (2)** by using 2 pieces of **Bolts (A)** with 2 pieces of **Spring Washer (C)**, 2 pieces of **Washer (B)** into the **Bed Frame (2)**.

Then tighten the **Bolts (A)** by using **Allen Wrench (D)**.

Repeat the same procedure for each bolt and each side of the **Bed Frame (2)**.

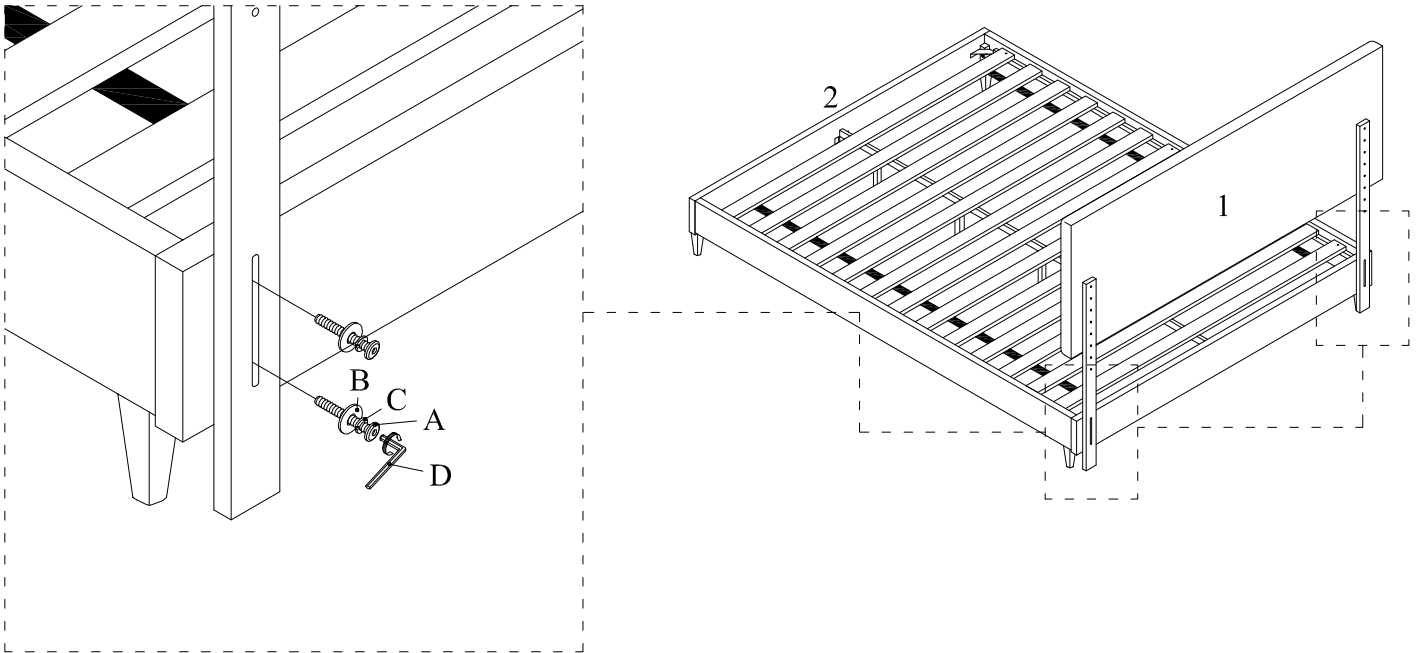

A x 4	B x 4	C x 4	D x 1

Hardware & Tool required

STEP 2:

Carefully position the assembled bed to the desired location by four adults.

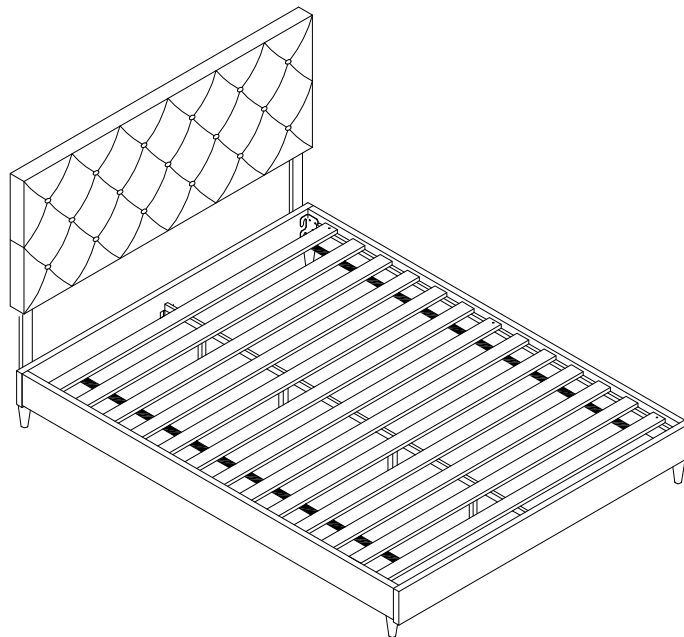

Assembly is complete. The headboard is ready to use now!

NOTE: Hardware may loosen over time. Periodically check that all connections are tight.

MODWAY HEADBOARD





Thank you for purchasing the **MOD-5365/5366/5367/5368/5369/5370/5371/5372/5373/5374/5375/5376/5377/5378/5379/5380/5381/5382/5383/5384/5385/5386/5387/5388/5389/5390/5391/5392/5393/5394/5395/5396/5397/5398/5399/5400/5401/5402/5403/5404/5405/5406/5407/5408 HEADBOARD !**

Before you start, here is some helpful advice:

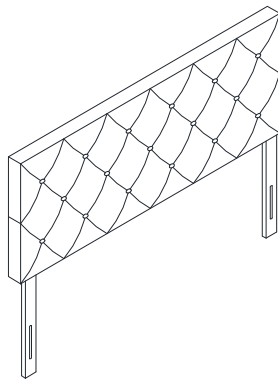
1. We suggest you spend a short time reading through this leaflet and then follow the simple step by step instructions.
2. Owing to the size and weight of the headboard, we recommend that it is assembled by two adults, on a carpeted or padded area, in the room that it is intended for. Approx assembly time: 30 minutes.
3. Please do not use any tools other than those provided or recommended in these instructions.
4. Please do not throw away any of the packaging or the instruction until you have checked all the components and hardware and the furniture is fully assembled. Please ensure that the packaging is disposed of in a safe environmentally friendly way.
5. Assemble all components loosely until advised to tighten. Depending on use, it may be necessary to tighten the components from time to time, so please save the tools that has been provided.
6. Please keep all fitting out of reach of children.



Hardware:

A		Bolt M8x45mm	x4
B		Flat Washer M8xD22mm	x4
C		Allen Wrench M5	x1

Component:

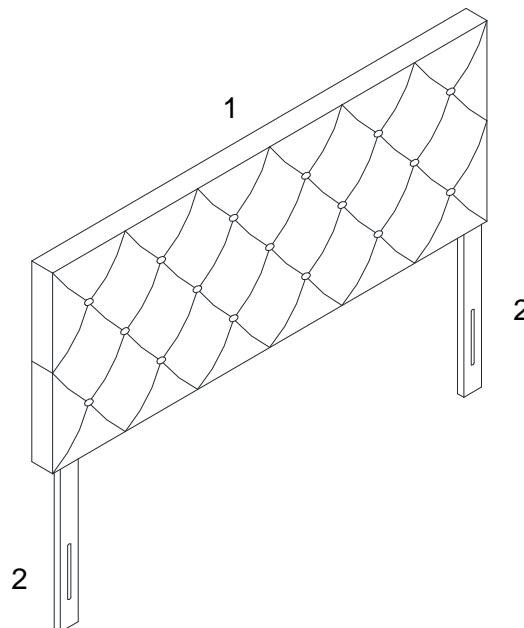

1 Headboard x1
(Style may vary)

2 Low Post x2



STEP 1:

Put the **Headboard (1)** upside down on a carpeted or padded area by two adults

Then insert the **Low Posts (2)** into the bottom of **Headboard (1)** and align pre-drilled **Low Post (2)** holes to the pre-drilled **Headboard (1)** Holes according to your desired headboard height.

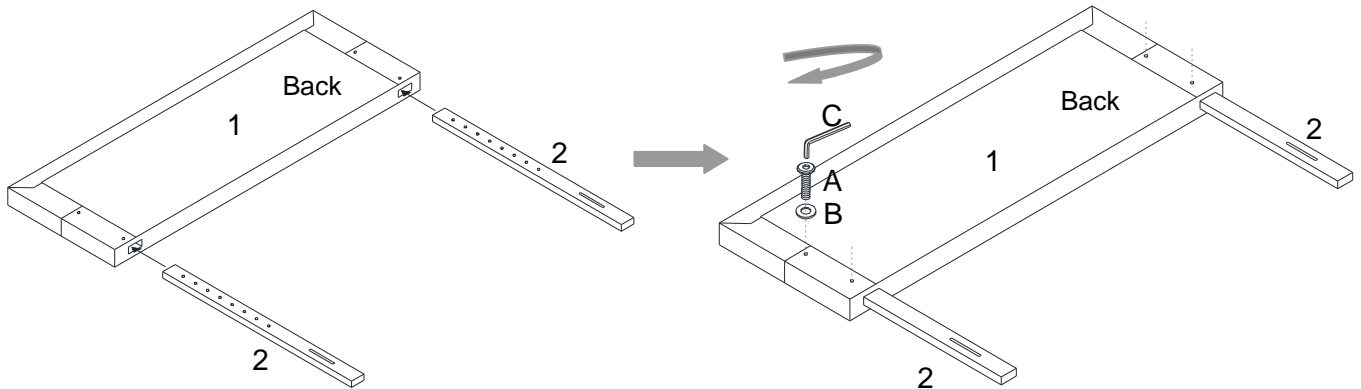
Attach each of **Low Post (2)** by using 2 piece of **Flat Washer (B)** and 2 pieces of **Bolt (A)** from the holes on the back of **Low Post (2)** and **Headboard (1)**. Tighten with **Allen Wrench (C)**.



		
Ax4	Bx4	Cx1

Hardware & Tool required

STEP 2:

Carefully turn up the assembled **Headboard (1)** by two adults.

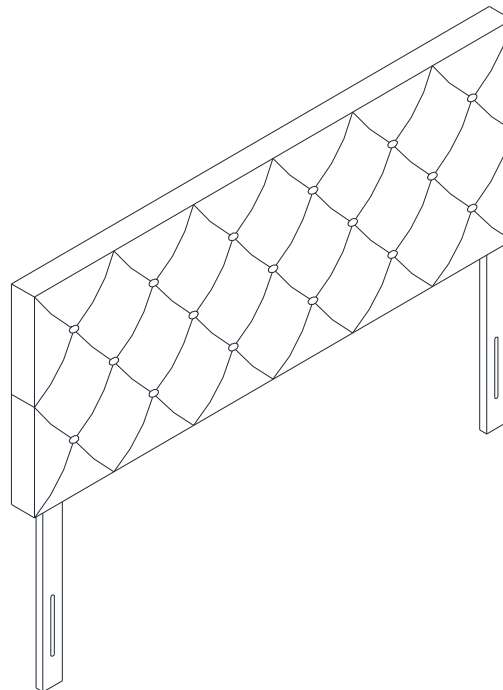

Assembly is completed. The headboard is ready to use now!





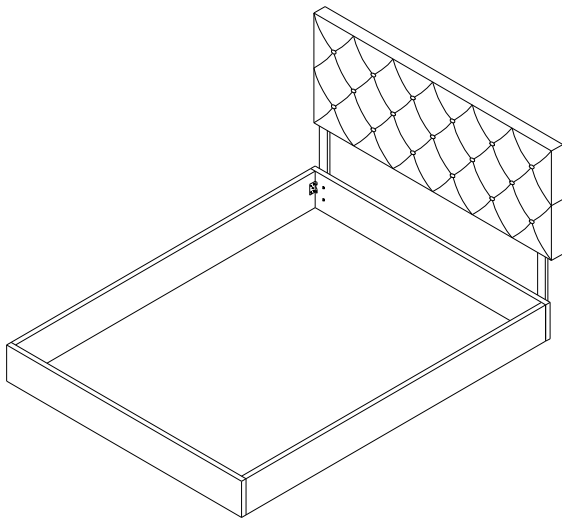

NOTE: Hardware may loosen over time. Periodically check that all connections are tight.

ASSEMBLY INSTRUCTIONS
OPTION 1

OPTION 1



Hardware:

A		Bolt M6x45mm	x4
B		Bolt M6x65mm	x4
C		Flat Washer M6xD22mm	x8
D		Spring Washer M6	x4
E		Hex Nut M6	x4
F		Allen Wrench M4	x1

Component:

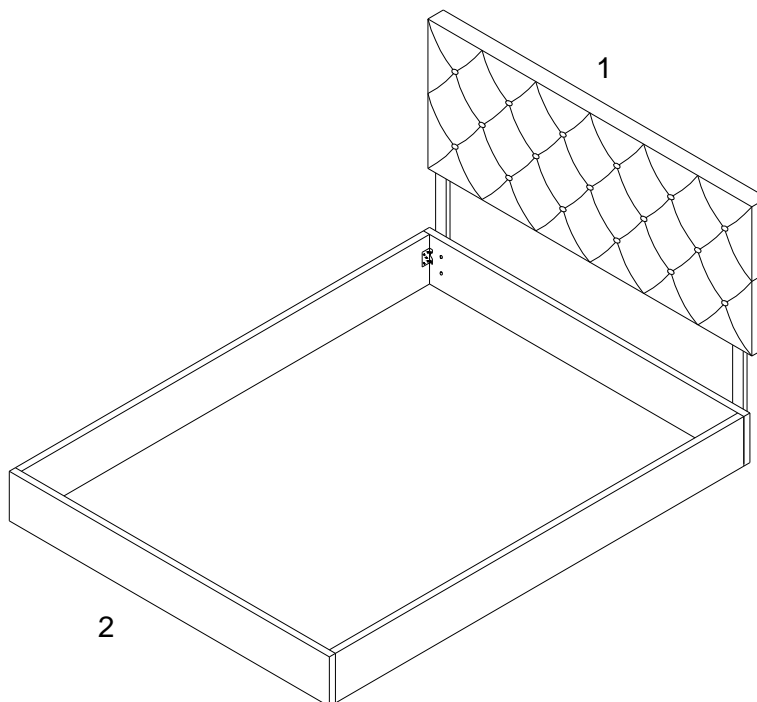

OPTION 1

1 Headboard x1
(Style may vary)

2 Bed Frame x1

Note: Extra hardware were provided for attaching the headboard to your Bed Frame (use is optional).

STEP 1:

Line up the **Bed Frame (2)** board's pre-drilled holes to match those of the **Headboard (1)**.





Secure the **Headboard (1)** to the **Bed Frame (2)** by using 2 pieces of **Bolt (B)** for the thicker **Bed Frame (2)**, and 2 pieces of **Bolt (A)** for the thinner **Bed Frame (2)**.

Before inserting each bolt, place 1 piece of **Spring Washer (D)** and **Flat Washer (C)** on each bolt. Then fit 1 piece of **Flat Washer (C)** on the bolt as it protrudes through the other side of the **Bed Frame (2)**.

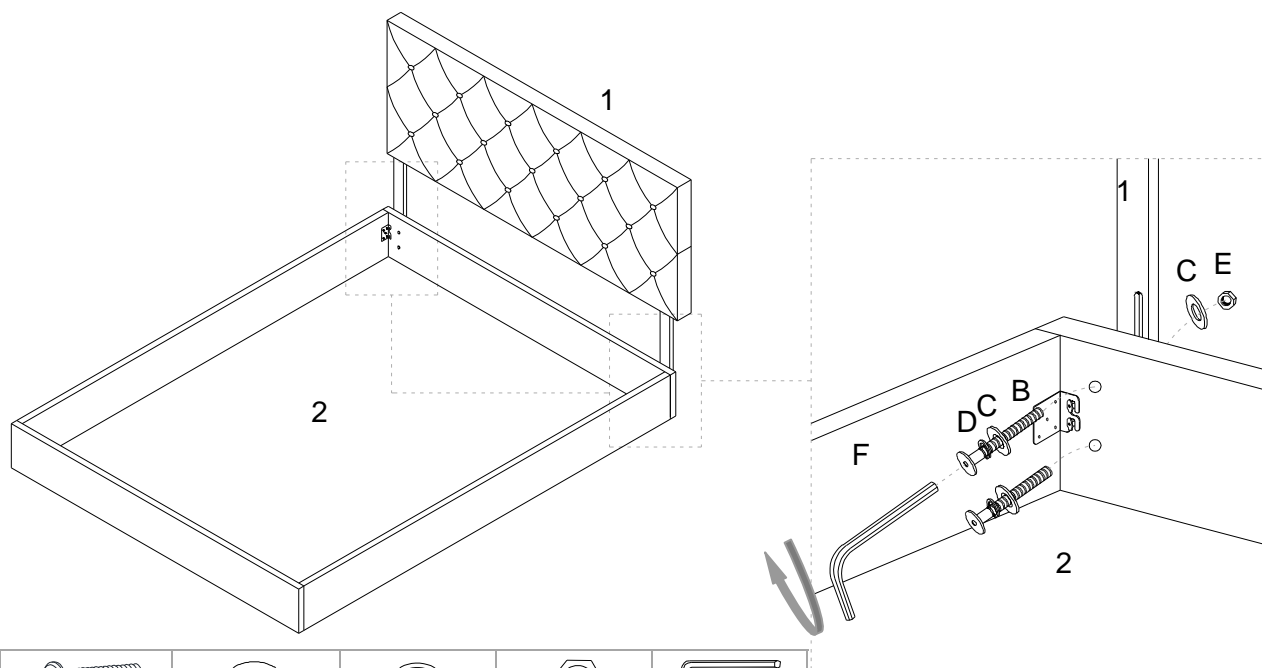
Place 1 piece of **Hex Nut (E)** after the **Flat Washer (C)** at the end of each bolt. Then tighten the **Bolts (A or B)** by using the **Allen Wrench (F)**.

Repeat the same procedure for each bolt and each side of the **Bed Frame (2)**.



				
A or Bx4	Cx8	Dx4	Ex4	Fx1

Hardware & Tool required

STEP 2:

Carefully position the assembled bed to the desired location by four adults.

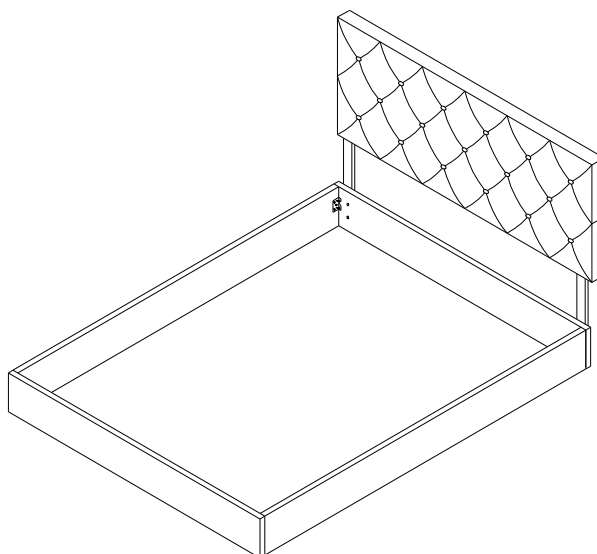

Assembly is completed. The bed is ready to use now!

NOTE: Hardware may loosen over time. Periodically check that all connections are tight.



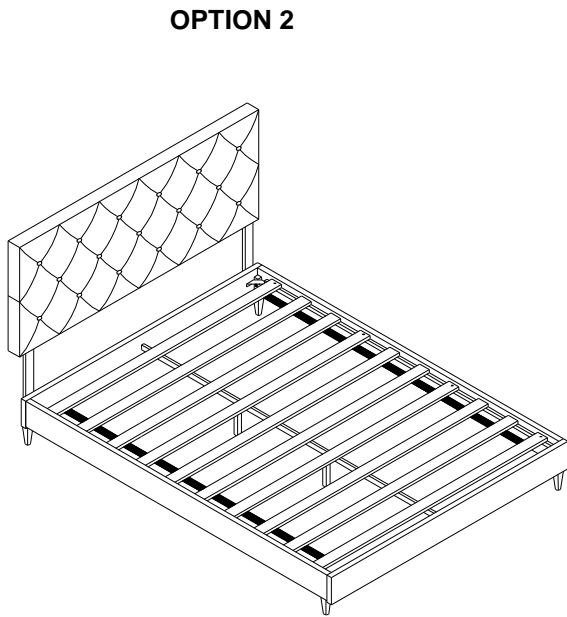

ASSEMBLY INSTRUCTIONS

OPTION 2

Note: This is assembly instruction for Headboard connect to MODWAY Bed Frame **MOD-5347/5348/5349/5350/5351/5352/5353/5354/5357/5358/5359/5360/5361/5362/5363/5364.**



Hardware:

A		Bolt M6x45mm	x4
B		Bolt M6x65mm	x4
C		Flat Washer M6xD22mm	x4
D		Spring Washer M6	x4
F		Allen Wrench M4	x1

Component:

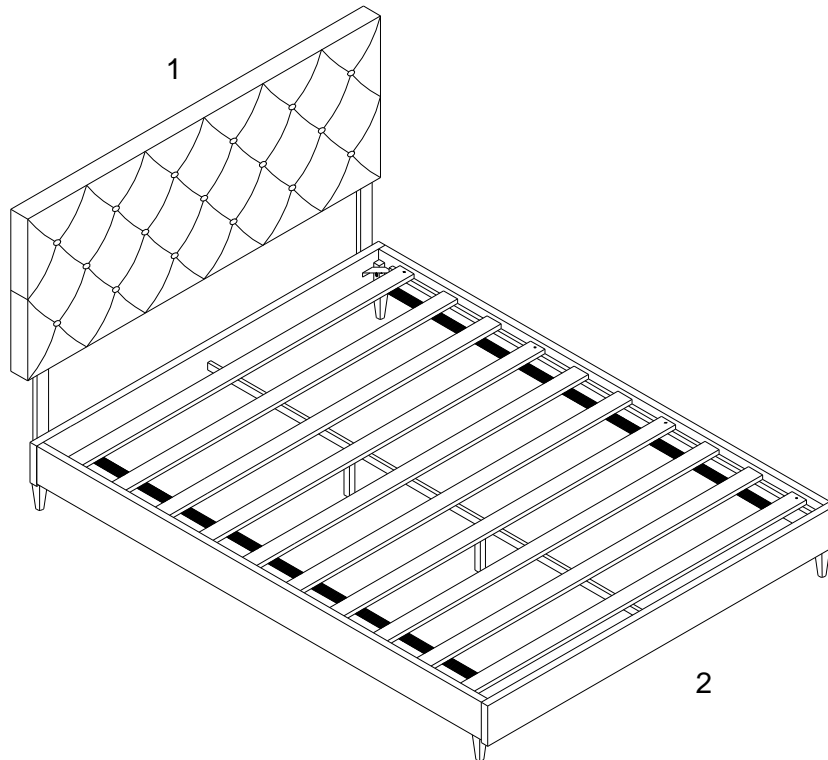

OPTION 2

1 Headboard x1
(Style may vary)

2 Bed Frame x1
(Style may vary)

STEP 1:





Line up the **Bed Frame (2)** board's pre-drilled holes to match those of the **Headboard (1)**.

Secure the **Headboard (1)** to the **Bed Frame (2)** by using 2 pieces of **Bolt (B)** with 2 pieces of **Spring Washer (D)**, 2 pieces of **Flat Washer (C)** for the thicker **Bed Frame (2)**, and 2 pieces of **Bolt (A)** with 2 pieces of **Spring Washer (D)**, 2 pieces of **Flat Washer (C)** for the thinner **Bed Frame (2)**.

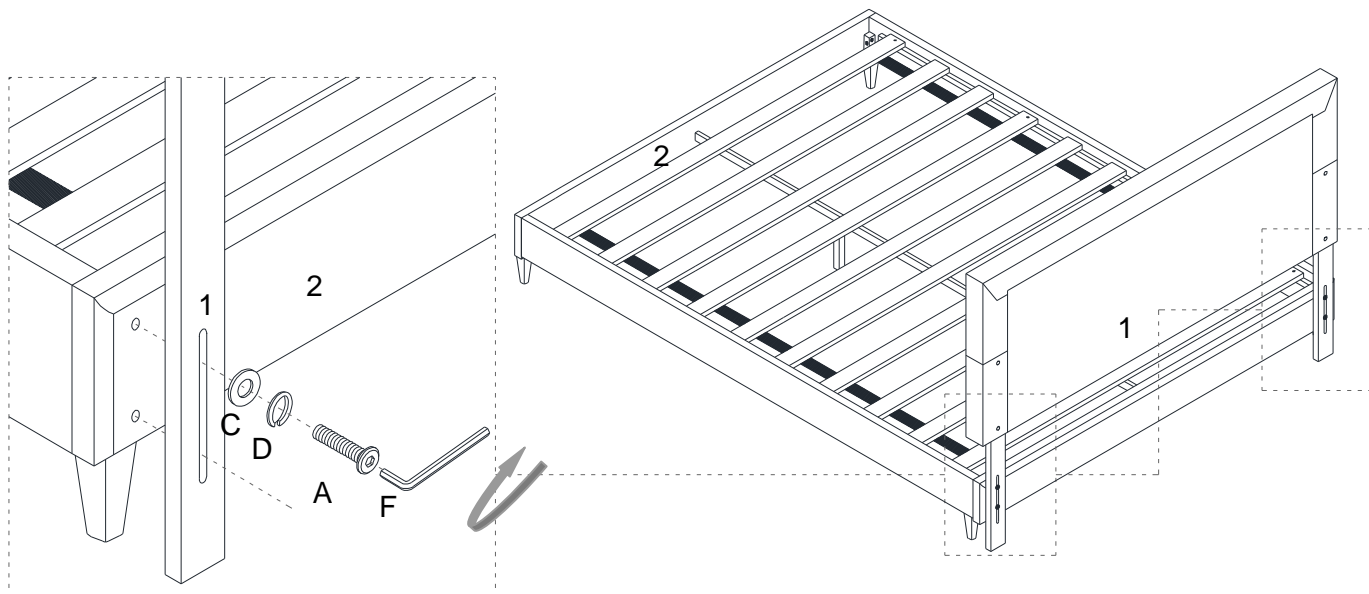
Then tighten the **Bolts (A or B)** by using the **Allen Wrench (F)**.

Repeat the same procedure for each bolt and each side of the **Bed Frame (2)**.



			
A or Bx4	Cx4	Dx4	Fx1

Hardware & Tool required

STEP 2:

Carefully position the assembled bed to the desired location by four adults.

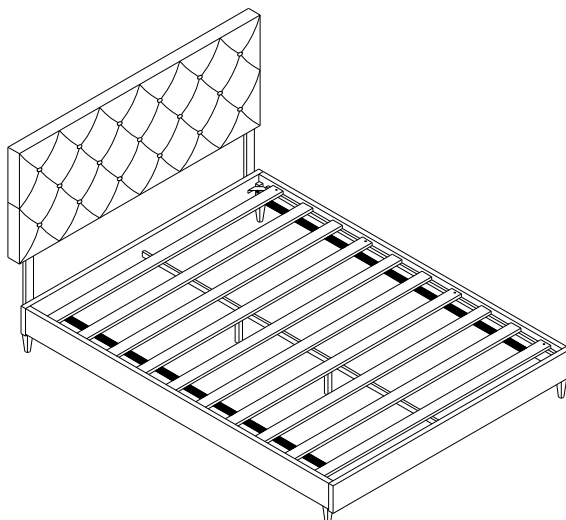

Assembly is completed. The bed is ready to use now!

NOTE: Hardware may loosen over time. Periodically check that all connections are tight.