

# ASSEMBLY INSTRUCTION

## DINING CHAIR

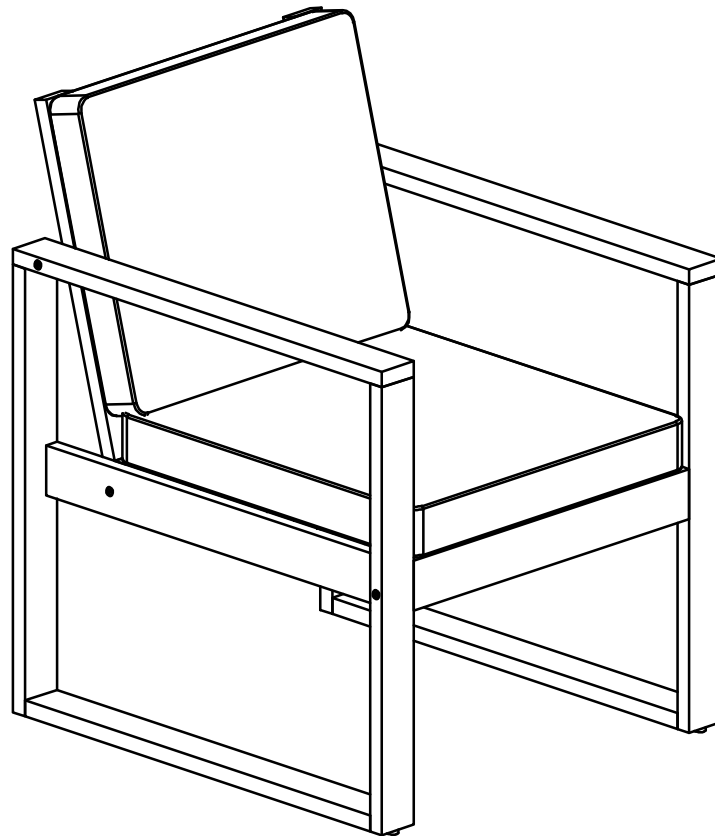

N715P251907

Please read all instructions carefully:

1. Have 2 adults on hand for assembly.
2. 50% Tighten before fixing all screws, Allen wrench is recommended instead of an electric drill.
3. Place the item on a flat ground to adjust and make sure it remains stable.
4. Tighten up all screws with tools gradually.
5. If the screws are not aligned with holes during assembly, please loosen all the other screws to 50% and continue the assembly process.
6. If the item is not stable, please loosen all the screws, adjust it on a flat ground and tighten up all screws again.
7. Note : If one or some screws are fully tightened during assembly, chances are the others will not be aligned with holes. In addition, all the holes are designed to be relatively larger to provide more space for the adjustment of the screws.

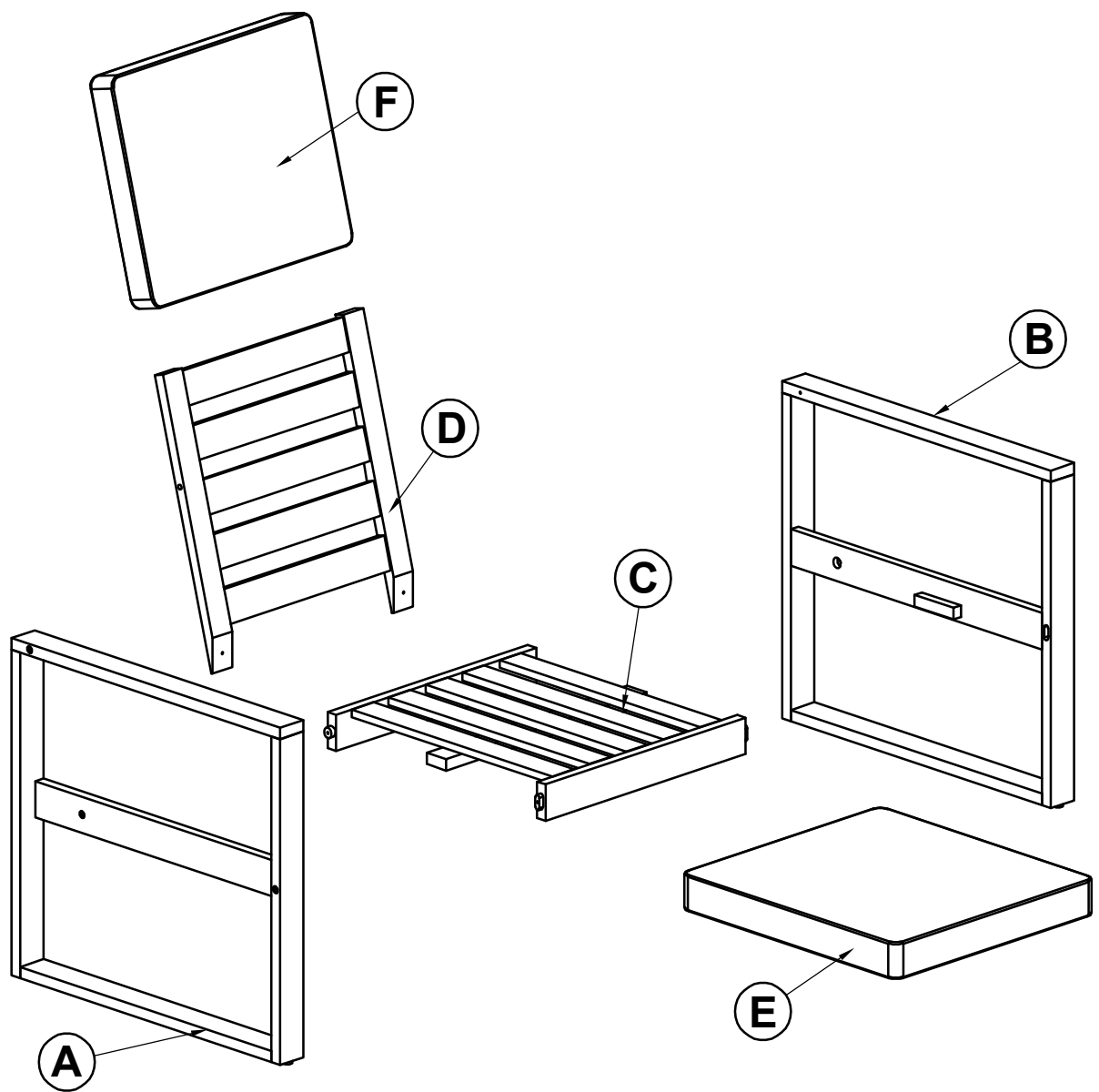

# Part List :

**A**

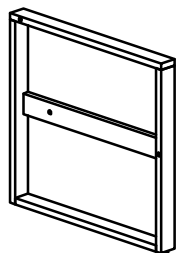

Left Leg Panel (1 pc)

**B**

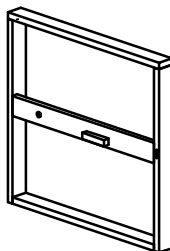

Right Leg Panel (1 pc)

**C**

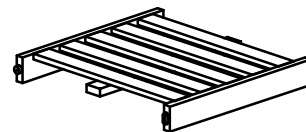

Seat Panel (1 pc)

**D**



Backrest Panel (1 pc)

**E**

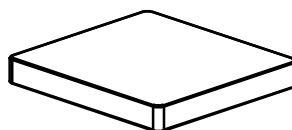

Seat Cushion (1 pc)

**F**

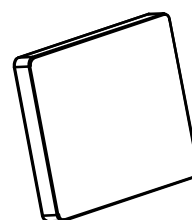

Back Cushion (1 pc)

# Hardware list:

1

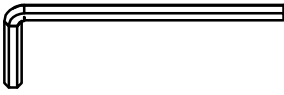

Allen Wrench (1 pc)

2



Screw Bolt M6x30(2 pcs)  
+ Extra 1 pc

3



Screw Bolt M6x60 (2 pcs)  
+ Extra 1 pc

4



Screw Bolt M6x90 (2 pcs)  
+ Extra 1 pc

5



Bolt M6x80 (2 pcs)  
+ Extra 1 pc

# STEP 1

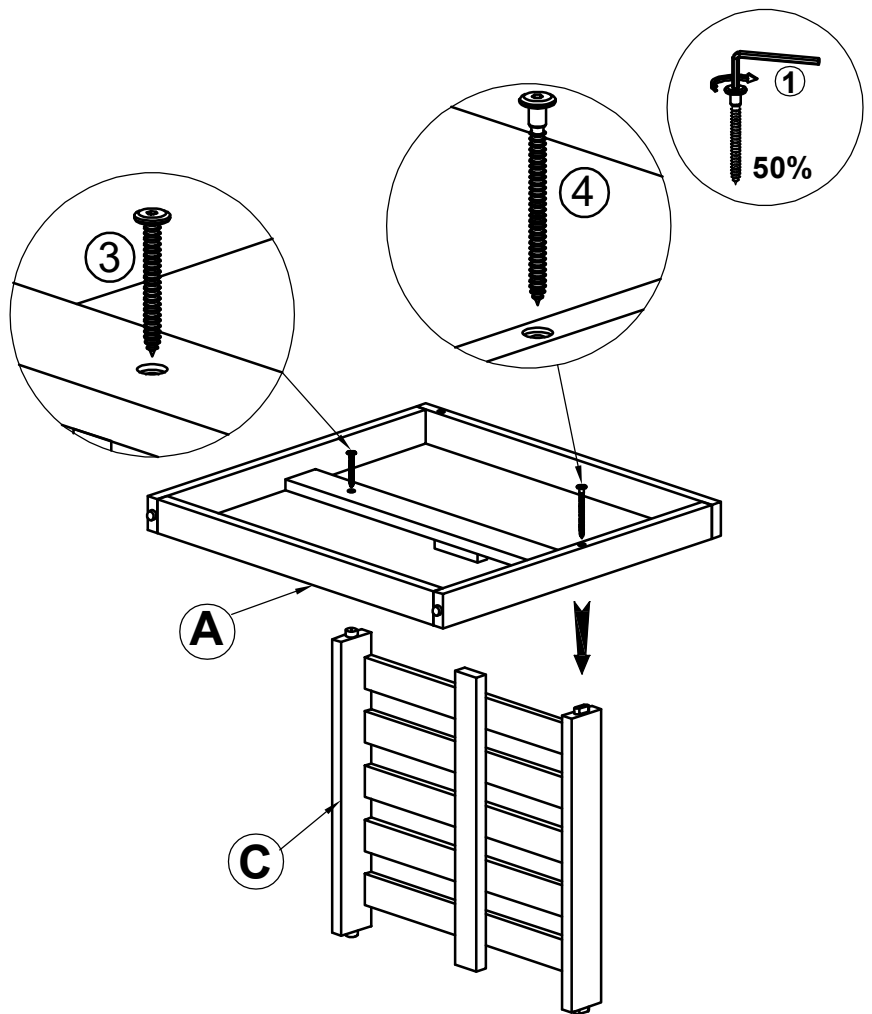
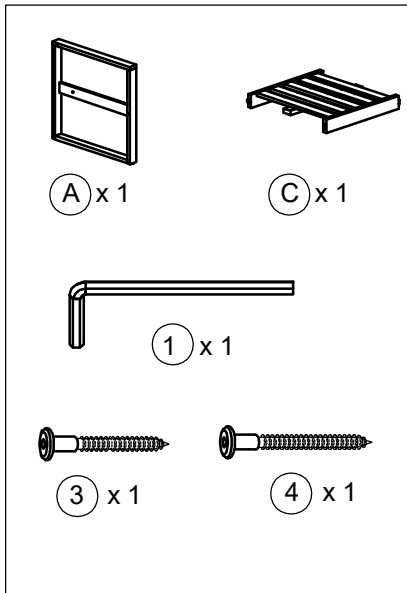

# STEP 2

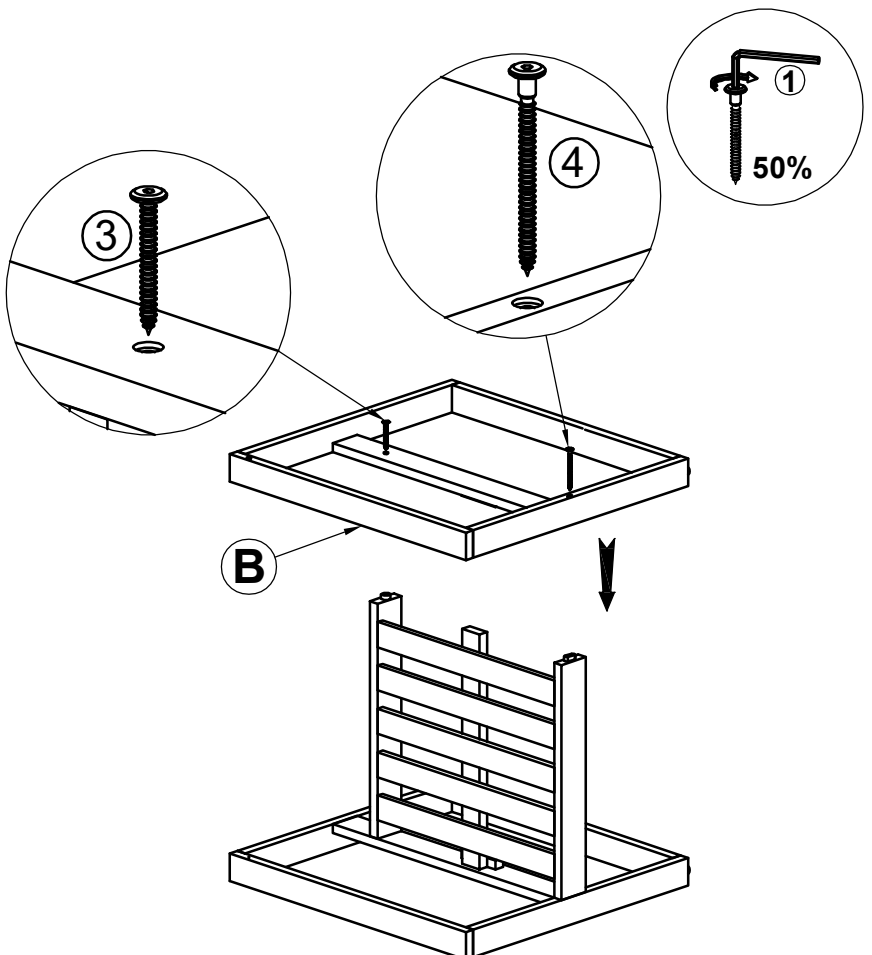
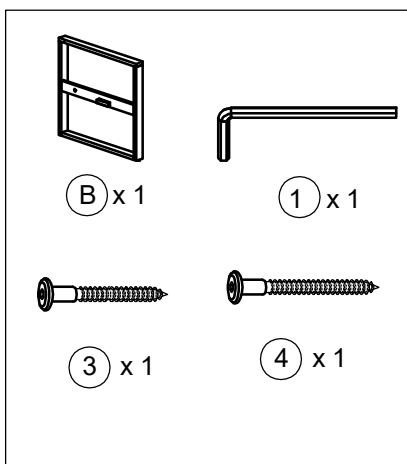

### STEP 3

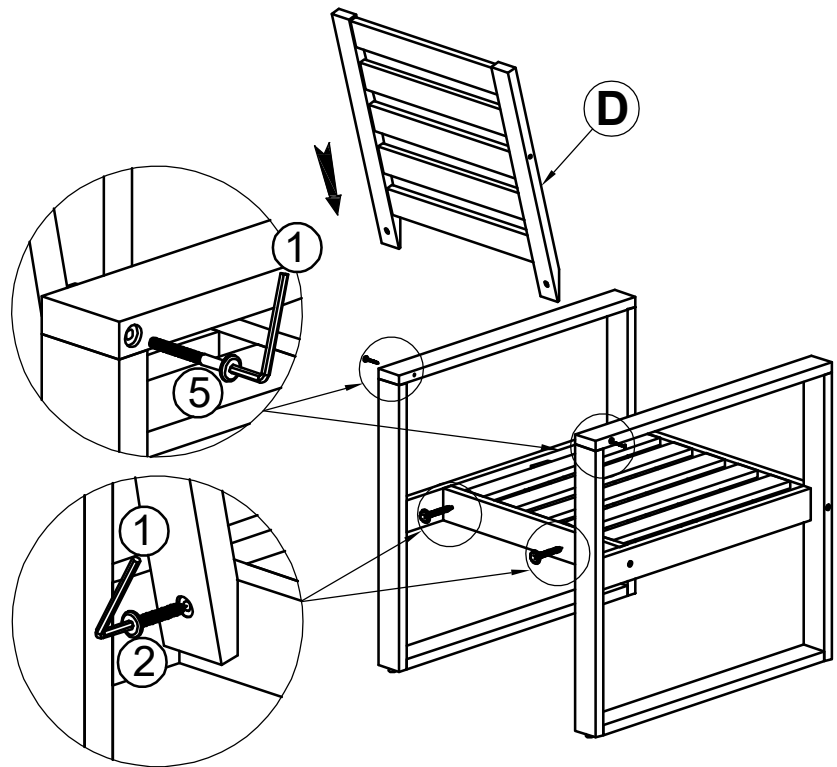
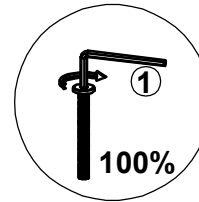
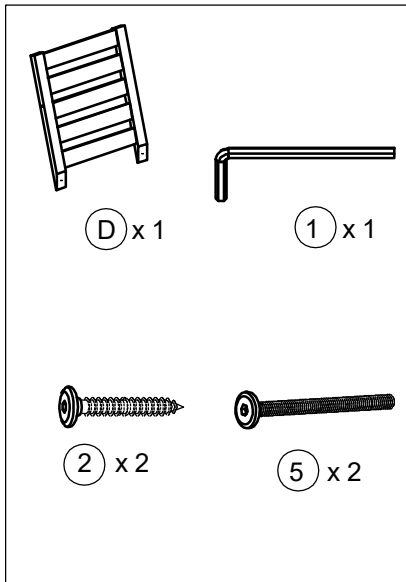

### STEP 4

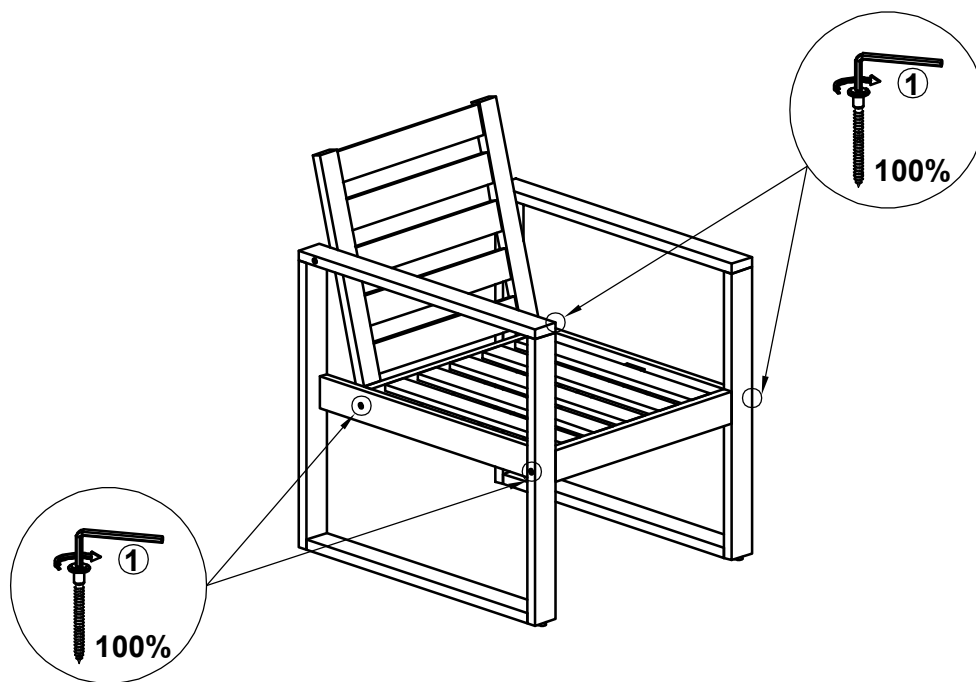

## STEP 5

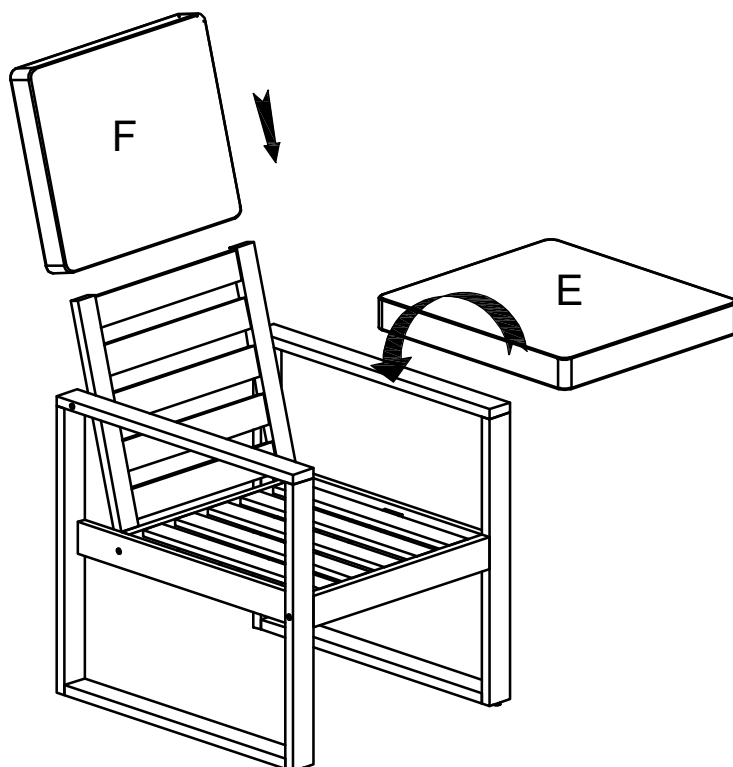
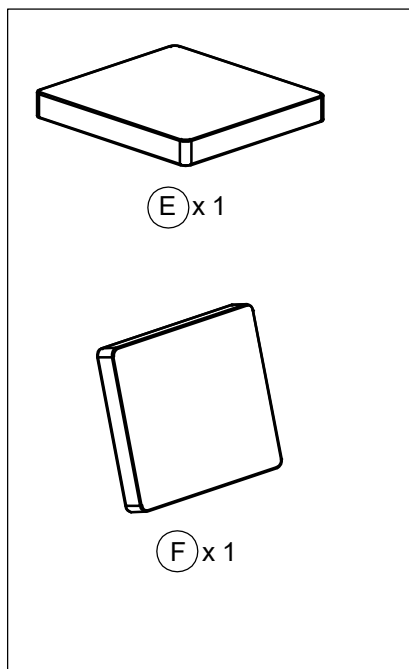

## STEP 6

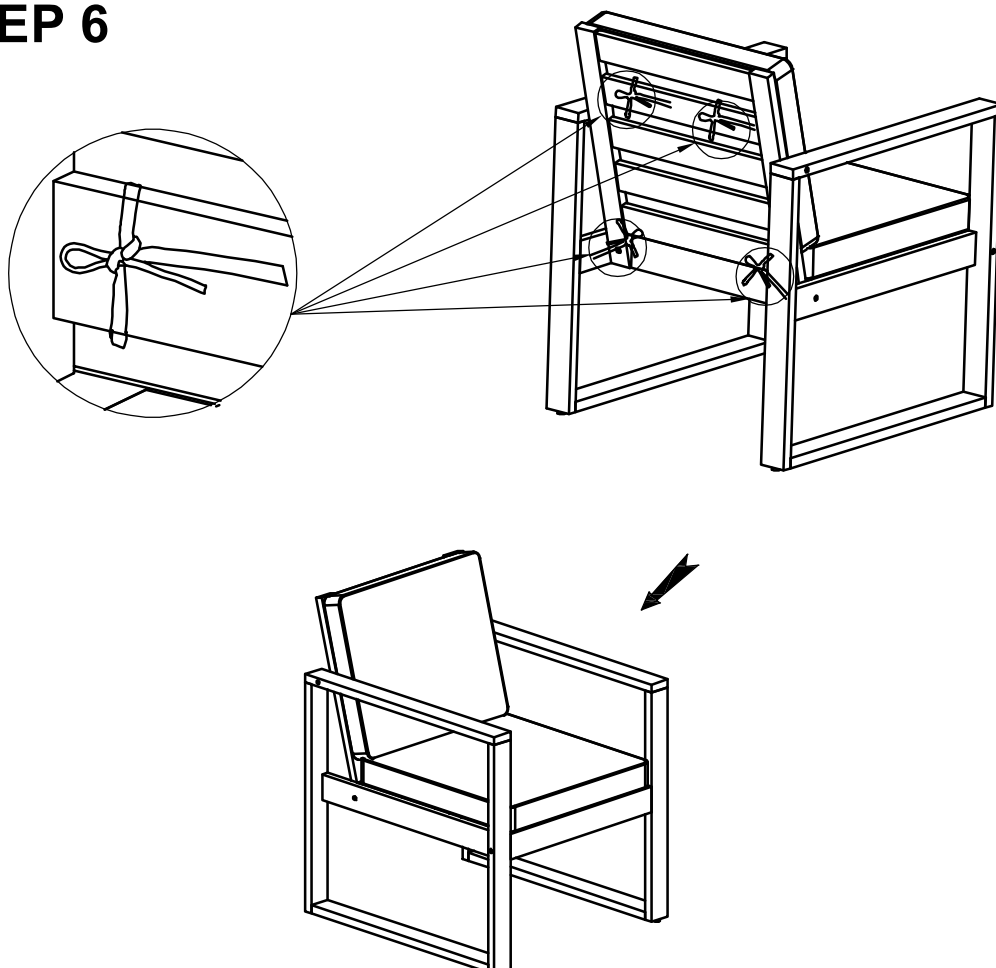

# ASSEMBLY INSTRUCTION

## DINING TABLE

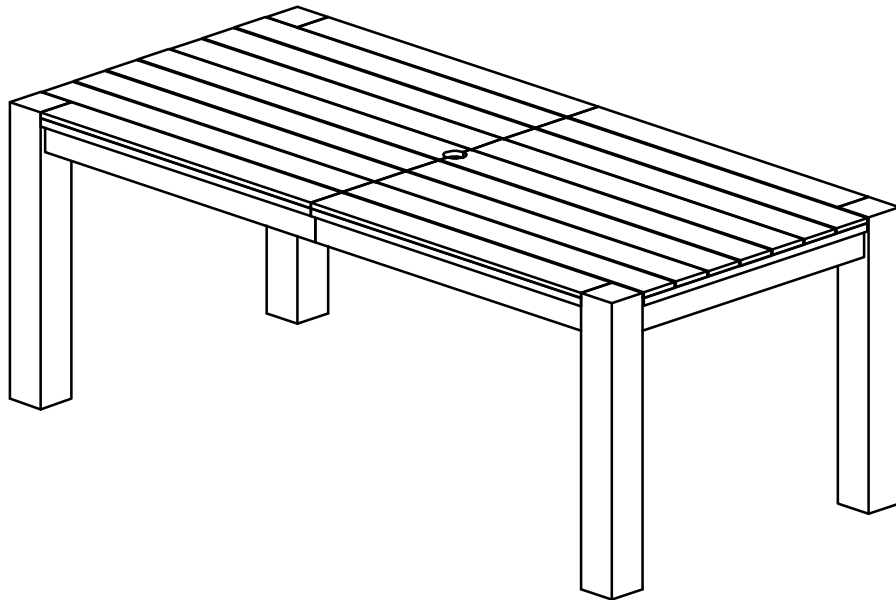

N715P251908

Please read all instructions carefully:

1. Have 2 adults on hand for assembly.
2. 50% Tighten before fixing all screws, Allen wrench is recommended instead of an electric drill.
3. Place the item on a flat ground to adjust and make sure it remains stable.
4. Tighten up all screws with tools gradually.
5. If the screws are not aligned with holes during assembly, please loosen all the other screws to 50% and continue the assembly process.
6. If the item is not stable, please loosen all the screws, adjust it on a flat ground and tighten up all screws again.
7. Note : If one or some screws are fully tightened during assembly, chances are the others will not be aligned with holes. In addition, all the holes are designed to be relatively larger to provide more space for the adjustment of the screws.



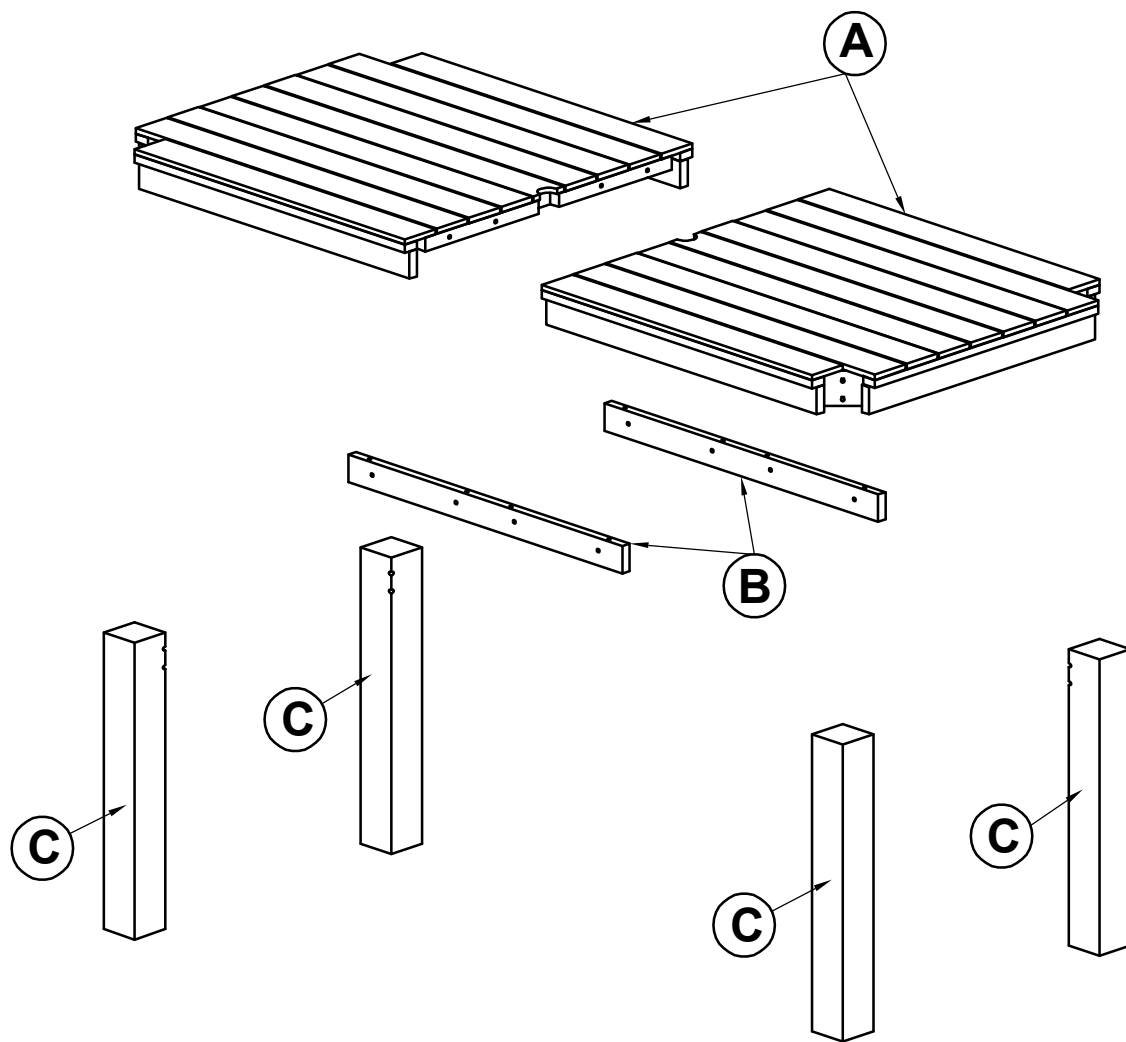

# Part List :

**A**

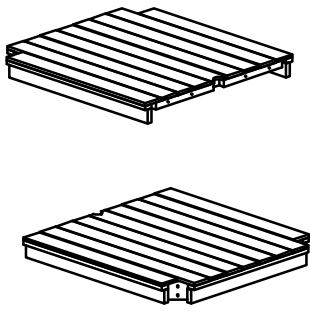

Table Top (2 pcs)

**B**

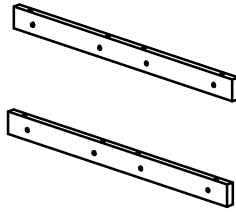
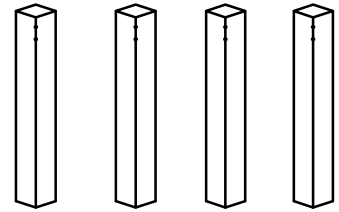



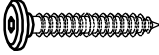
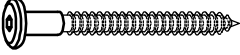





Table top connection (2 pcs)

**C**



Leg (4 pcs)

# Hardware list:

<b>1</b>  Allen Wrench (2 pcs)	<b>2</b>  Screw Bolt M6x35 (8 pcs) + Extra 1 pc	<b>3</b>  Screw Bolt M6x80 (8 pcs) + Extra 1 pc	<b>4</b>  Bolt M6x45 (4pcs) + Extra 1 pc
<b>5</b>  Sleeve Nut M6x18 (4 pcs) + Extra 1 pc	<b>6</b>  Bolt M8x80(8 pcs) + Extra 1 pc	<b>7</b>  Flat Washer M6 (8 pcs) + Extra 1 pc	<b>8</b>  Warp Washer M6 (8 pcs) + Extra 1 pc

# STEP 1

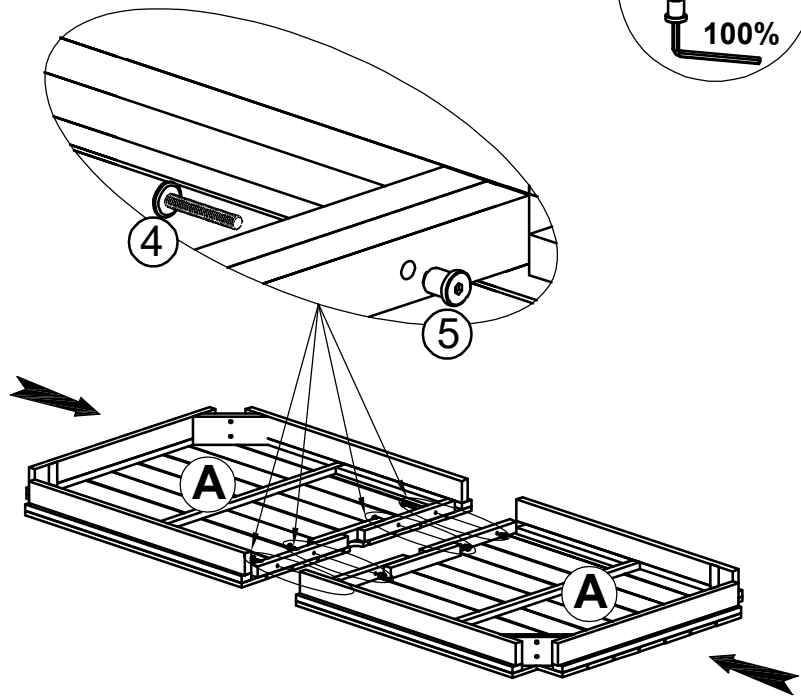
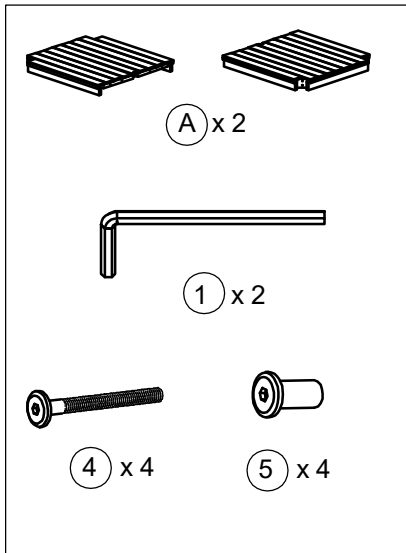

# STEP 2

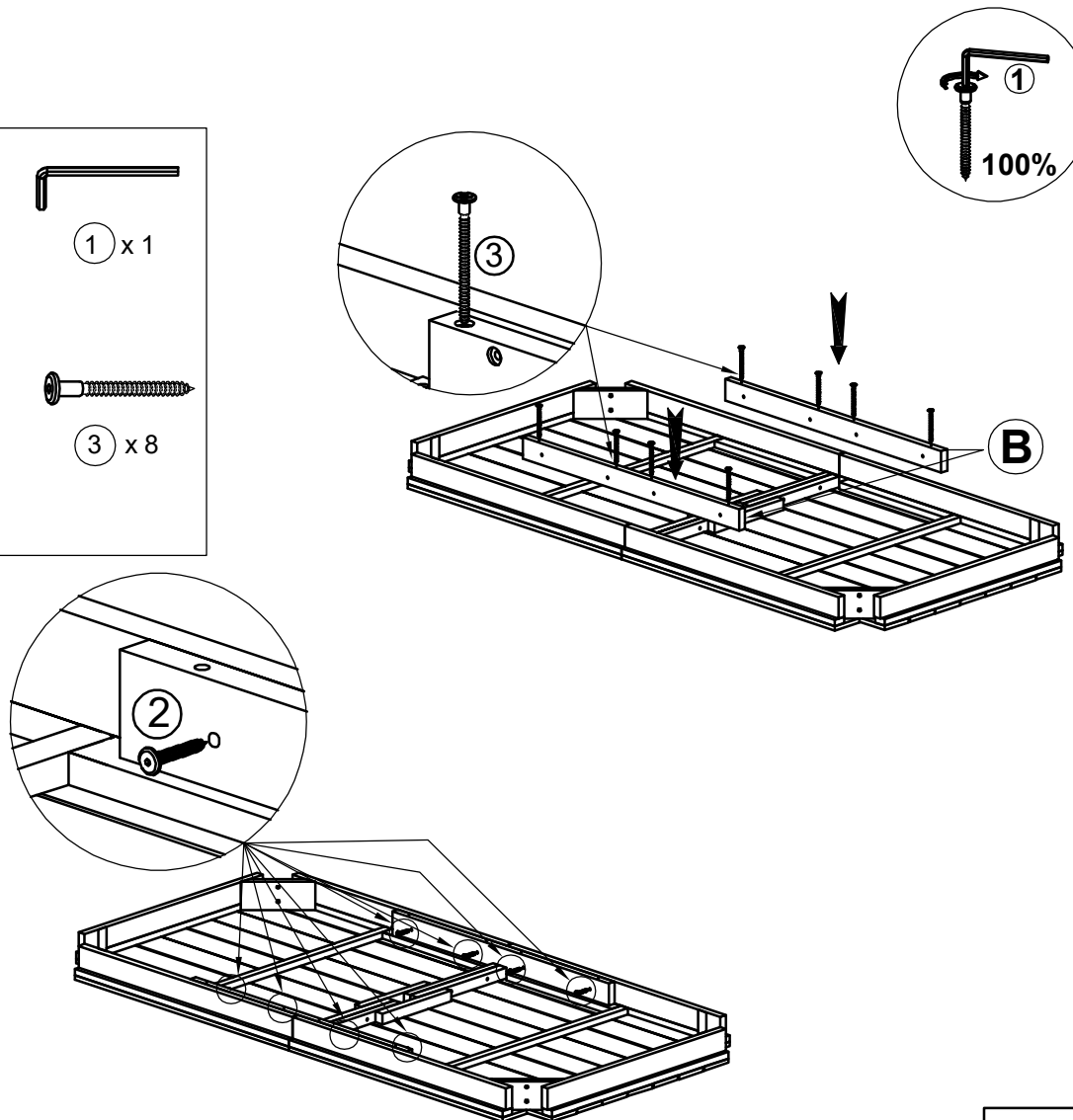
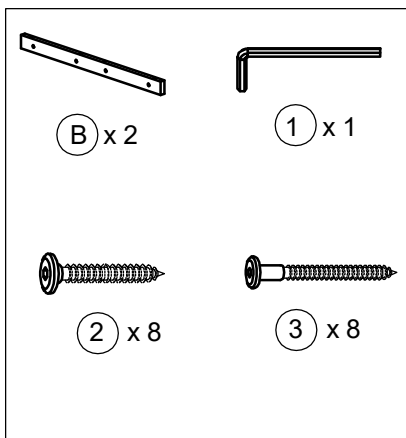

### STEP 3

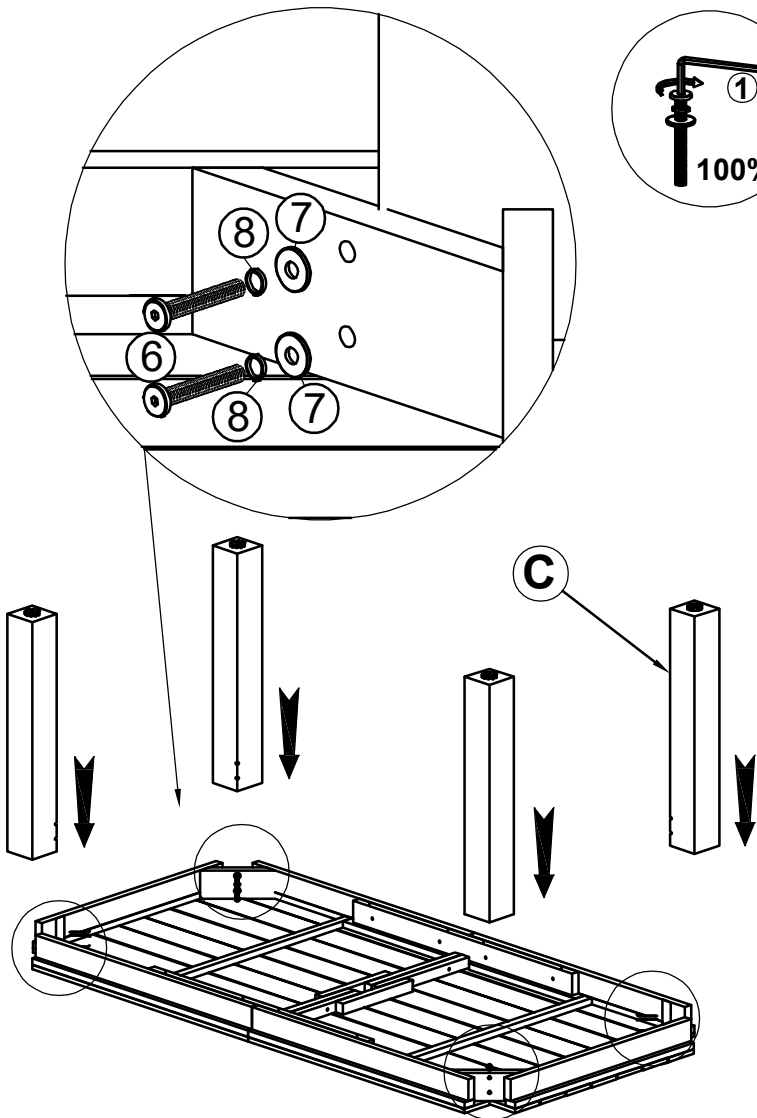
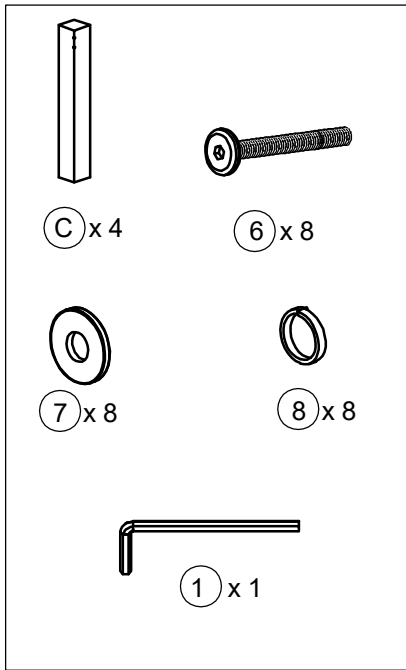

### STEP 4

