

# DOREL ASIA

---

## DOUBLE ROCKER

**Model No:**

WM6094 (Cocoa)

WM6094-DO (Doe)

**UPC CODE:**

WM6094

0-65857-16299-8

WM6094-DO

0-65857-16686-6

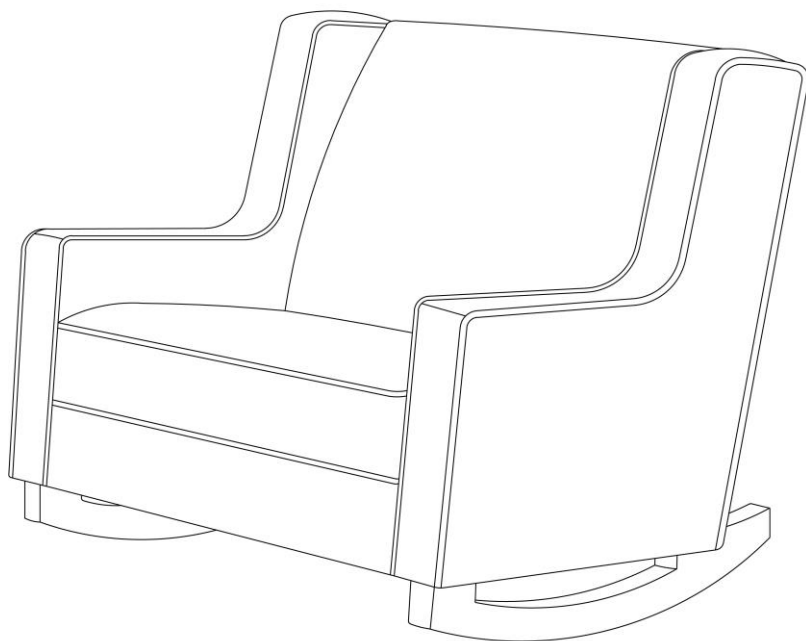

**NOTE:**

THIS INSTRUCTION BOOKLET  
CONTAINS **IMPORTANT** SAFETY  
INFORMATION. PLEASE READ AND  
KEEP FOR FUTURE REFERENCE.

**Lot number:**

(TAKEN FROM CARTON)

\_\_\_\_\_

**Date of purchase:**

\_\_\_\_ / \_\_\_\_ / \_\_\_\_

**DO NOT RETURN PRODUCT TO THE STORE.**

If a part is missing or damaged, contact our customer service department. We will replace the part **FREE** of charge.



**Tel #:** 1-800-295-1980

**E-Mail:** das@dorel.com

**Fax #:** 514-353-7819

## CUSTOMER SERVICE

If you are missing parts or have any questions about this product, contact our customer service representative first!



**CALL 1-800-295-1980**

You can also order parts by writing to the address listed below. Please include the product model number, color and a detailed description of the part.

**Customer Service Department No. 413  
12345 Albert-Hudon Boulevard, Suite 100  
Montreal, Quebec  
Canada H1G 3L1**

**E-MAIL: [das@dorel.com](mailto:das@dorel.com)**

## NOTES

- \* Ensure all parts and components are present before beginning assembly.
- \* Assemble on a clean, smooth surface to prevent damage to product finish.
- \* **DO NOT** use power tools.
- \* **CAUTION:** Adult assembly required.
- \* Assembly and handling will require two people.
- \* Estimated assembly time: 8 minutes.

## CARE AND CLEANING

Dust regularly with a soft, dry cloth to prevent soil build up. Wipe away spills immediately to prevent staining. Use a cloth dampened with water or a professional product to clean the fabric. Always test an inconspicuous area first. Allow upholstery to dry and brush lightly. Keep away from heat to avoid glazing, melting or scorching.

## MAINTENANCE

Check bolts/screws periodically and tighten them if necessary.

## LIMITED WARRANTY





Dorel Asia warrants its product to be free from defects in material and workmanship and agrees to remedy any such defect. This warranty covers 1 year from the date of original purchase. This warranty is valid only upon presentation of proof of purchase. This is solely limited to the repair or replacement of defective furniture components and no assembly labor is included. This warranty does not apply to any product which has been improperly assembled, subjected to misuse or abuse or which has been altered or repaired in any way. Any wearing, tearing or fading of the fabric is not covered under the warranty. This warranty gives you specific legal rights and you may also have other rights which vary from State to State.



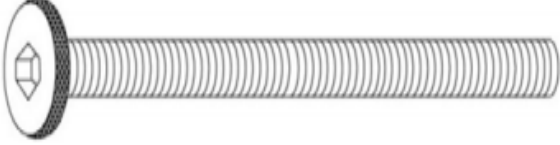
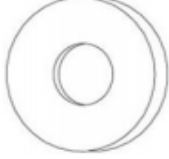

**WARNING: Should this product become damaged, and/or components are broken or missing, DO NOT USE.**

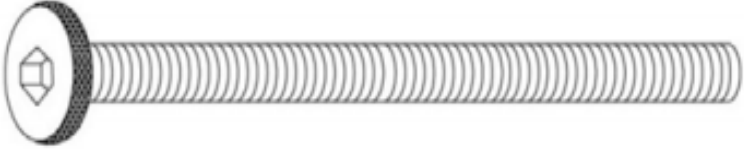
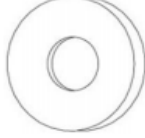
# DOUBLE ROCKER WM6094 / WM6094-DO

## HARDWARE LIST

<div style="border: 1px solid black; padding: 2px; width: 30px; margin: 0 auto;">1</div>  <p style="text-align: center;">Ø5/16" X 70mm</p> <p style="text-align: center;">HEX SOCKET HEAD BOLT 14 PCS</p>	<div style="border: 1px solid black; padding: 2px; width: 30px; margin: 0 auto;">2</div>  <p style="text-align: center;">Ø22 X 1.8mm</p> <p style="text-align: center;">FLAT WASHER 14 PCS</p>	<div style="border: 1px solid black; padding: 2px; width: 30px; margin: 0 auto;">3</div>  <p style="text-align: center;">Ø12.5 X 1.2mm</p> <p style="text-align: center;">SPRING WASHER 14 PCS</p>
<div style="border: 1px solid black; padding: 2px; width: 30px; margin: 0 auto;">4</div>  <p style="text-align: center;">Ø5/16" X 90mm</p> <p style="text-align: center;">HEX SOCKET HEAD BOLT 4 PCS</p>	<div style="border: 1px solid black; padding: 2px; width: 30px; margin: 0 auto;">5</div>  <p style="text-align: center;">Ø19 X 1.8mm</p> <p style="text-align: center;">FLAT WASHER 4 PCS</p>	<div style="border: 1px solid black; padding: 2px; width: 30px; margin: 0 auto;">6</div>  <p style="text-align: center;">ALLEN KEY 1PC</p>

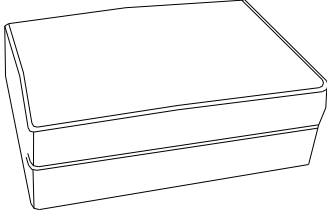
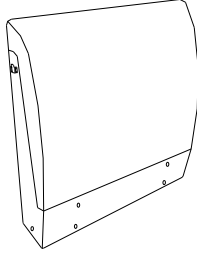
## PARTS LIST

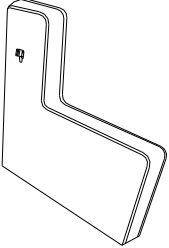
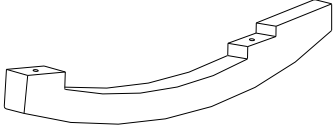
<div style="border: 1px solid black; padding: 2px; width: 30px; margin: 0 auto;">A</div>  <p style="text-align: center;">SEAT BASE 1 PC</p>	<div style="border: 1px solid black; padding: 2px; width: 30px; margin: 0 auto;">B</div>  <p style="text-align: center;">CHAIR BACK 1 PC</p>	<div style="border: 1px solid black; padding: 2px; width: 30px; margin: 0 auto;">C</div>  <p style="text-align: center;">LEFT ARM 1 PC</p>
<div style="border: 1px solid black; padding: 2px; width: 30px; margin: 0 auto;">D</div>  <p style="text-align: center;">RIGHT ARM 1 PC</p>	<div style="border: 1px solid black; padding: 2px; width: 30px; margin: 0 auto;">E</div>  <p style="text-align: center;">LEG 2 PCS</p>	

# DOUBLE ROCKER WM6094 / WM6094-DO

## STEP 1:

Place chair back (B) on a clean, smooth surface.

Pull back the fabric lining on seat base (A). Attach seat base (A) to chair back (B) with flat washers (2), spring washers (3) and hex socket head bolts (1). Use Allen key (6) to tighten the bolts.

Turn the assembled unit upright.

NOTE: Do not fully tighten the bolts. Leaving the bolts loose will facilitate assembly in the following steps.

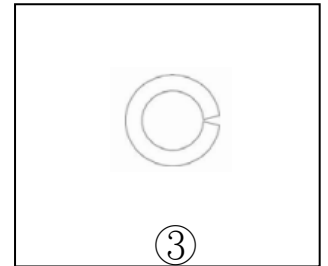
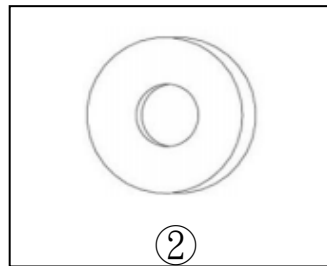
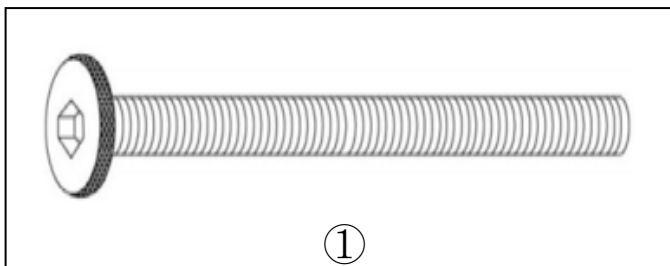
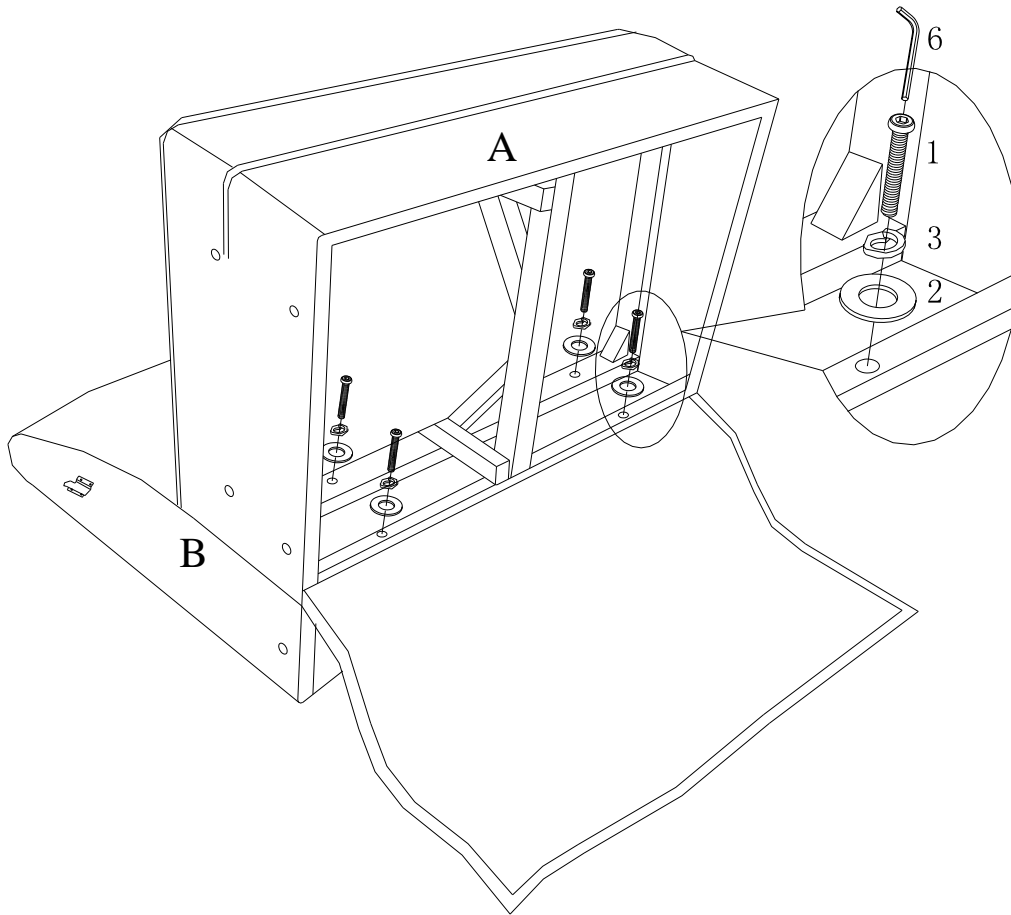

# DOUBLE ROCKER WM6094 / WM6094-DO

## STEP 2:

Attach left arm (C) to chair back (B) by inserting the metal bracket on left arm (C) into the metal glide on chair back (B). Push the left arm (C) with a downward force to secure it into place.

Repeat this step to attach right arm (D) to chair back (B).

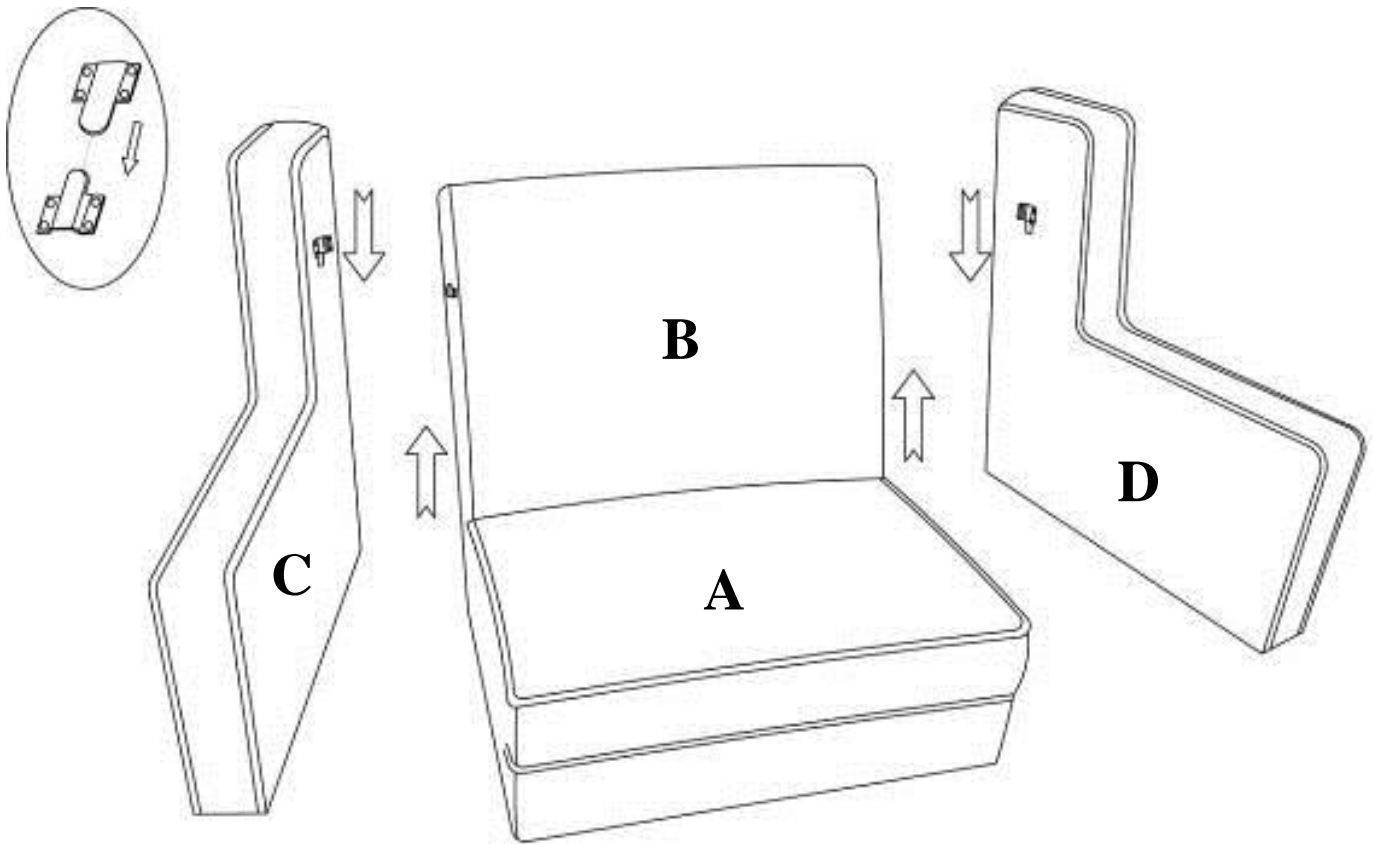

# DOUBLE ROCKER WM6094 / WM6094-DO

## STEP 3:

With the help of another person, gently place the unit on chair back (B) and pull back the fabric lining underneath seat base(A).

Secure left arm (C) and right arm (D) to seat base (A) with flat washers (2), spring washers (3) and hex socket head bolts (1). Use Allen key (6) to tighten the bolts.

Place the fabric lining back into place.

NOTE: Do not fully tighten the bolts. Leaving the bolts loose will facilitate assembly in the following steps.

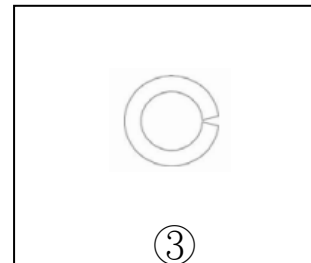
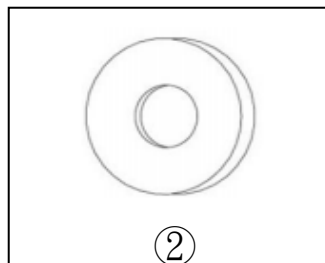
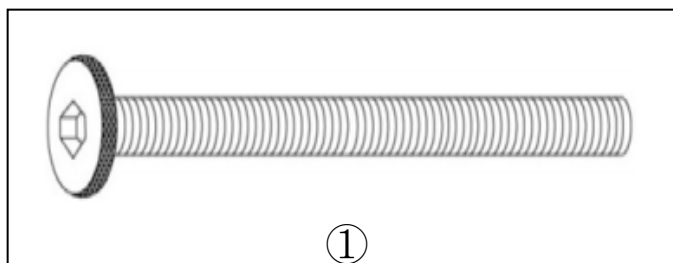
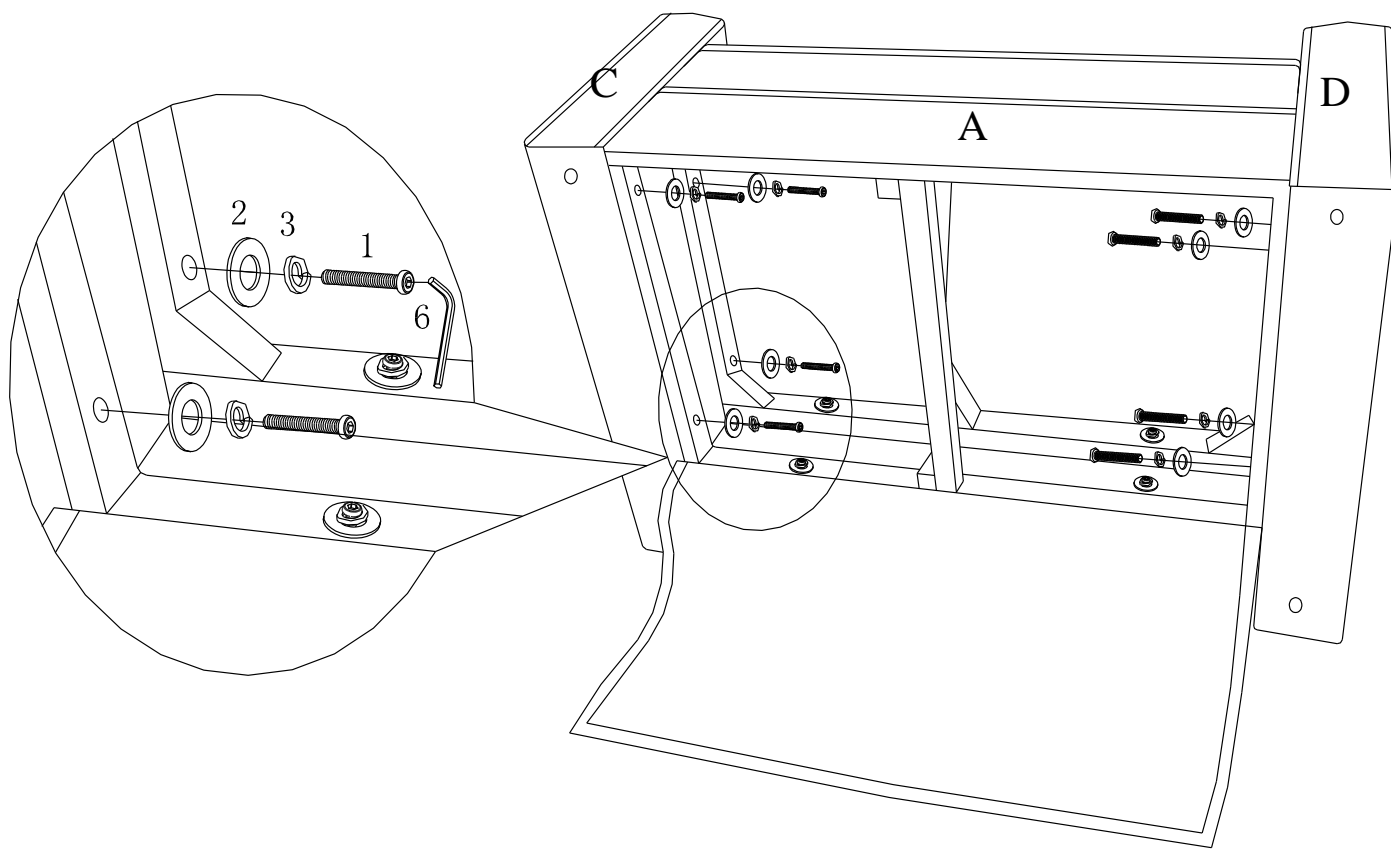

# DOUBLE ROCKER WM6094 / WM6094-DO

## STEP 4:

Pull back the lower fabric lining underneath chair back (B).

Secure left arm (C) and right arm (D) to chair back (B) with flat washers (2), spring washers (3) and hex socket head bolts (1). Use Allen key (6) to tighten the bolts.

Place the fabric lining back into place.

Note: Tighten all bolts previously installed.

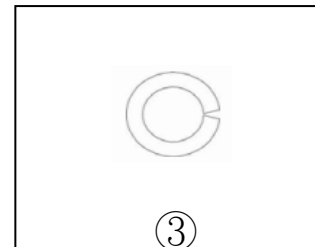
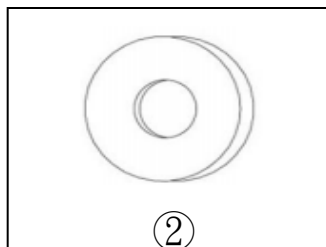
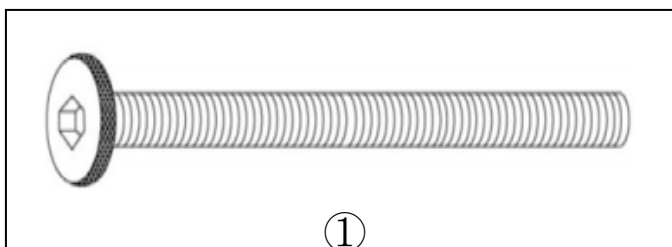
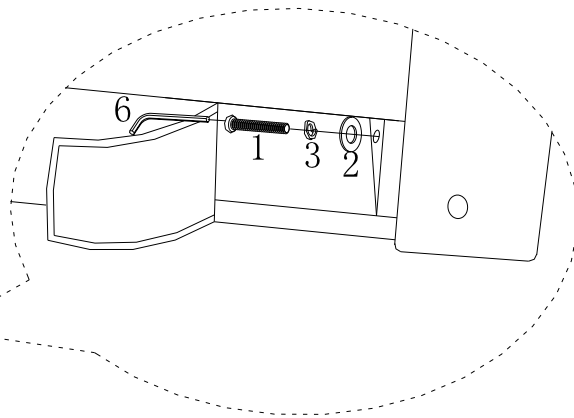
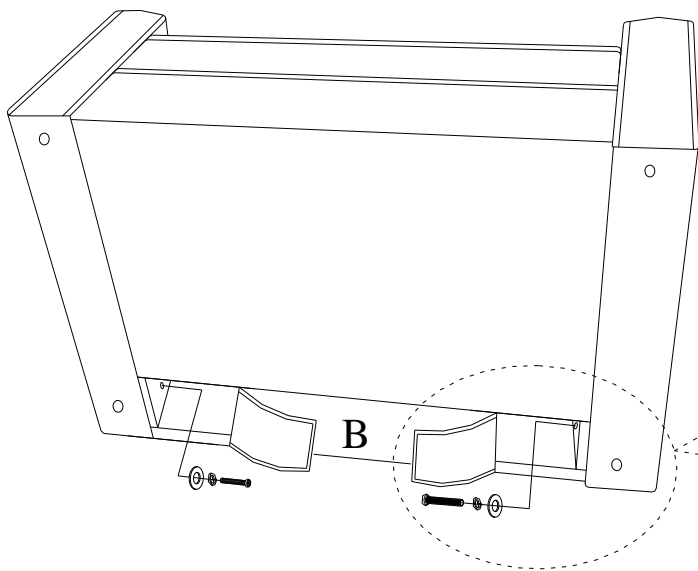
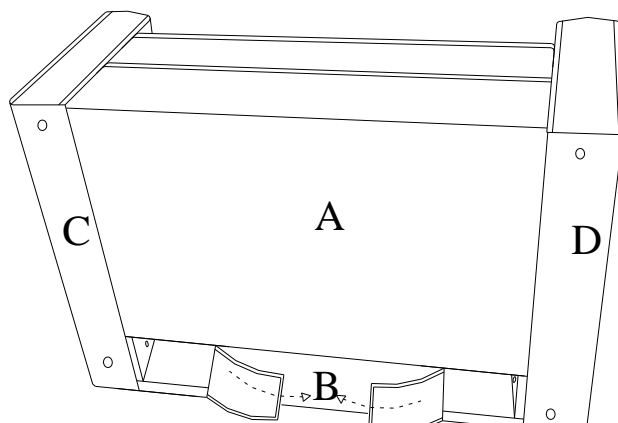

# DOUBLE ROCKER WM6094 / WM6094-DO

## STEP 5:

With the help of another person, gently turn the unit upside down.

Attach legs (E) to arms (C & D) with flat washers (5) and hex socket head bolts (4).

Use Allen key (6) to tighten the bolts.

Turn the rocker upright.

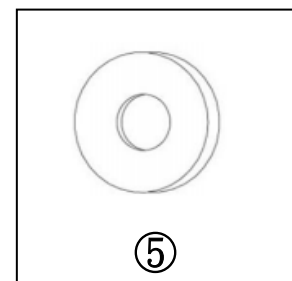
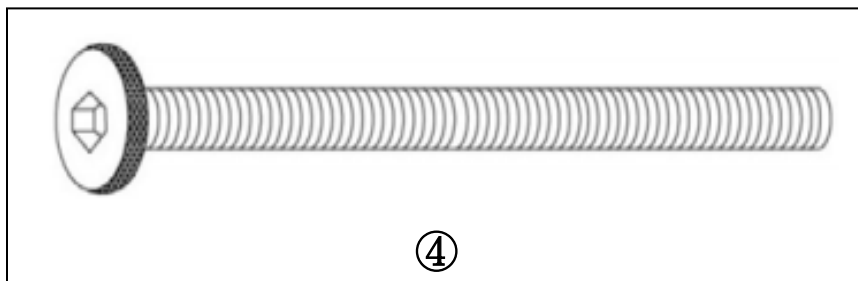
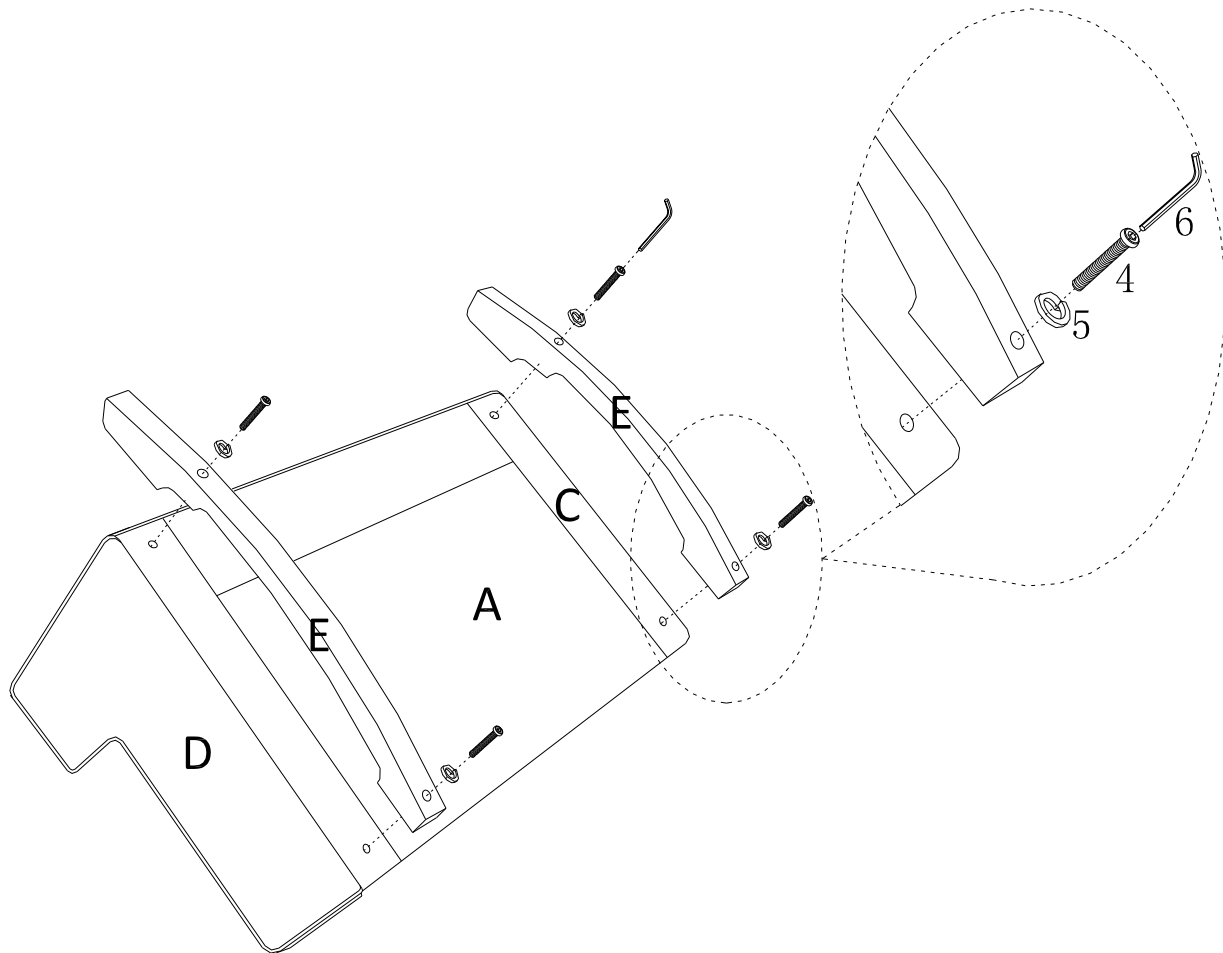

# DOUBLE ROCKER - WESTSIDE COCOA WM6094 / WM6094-DO



**CAUTION:** This unit is intended for use only with the products and/or maximum weights indicated. Use with other products and/or products heavier than the maximum weights indicated may result in instability or cause possible injury.

Dust regularly with a soft, dry cloth to prevent soil build up. Wipe away spills immediately to prevent staining. Use a cloth dampened with water or a professional product to clean the fabric. Always test an inconspicuous area first. Allow upholstery to dry and brush lightly. Keep away from heat to avoid glazing, melting or scorching.

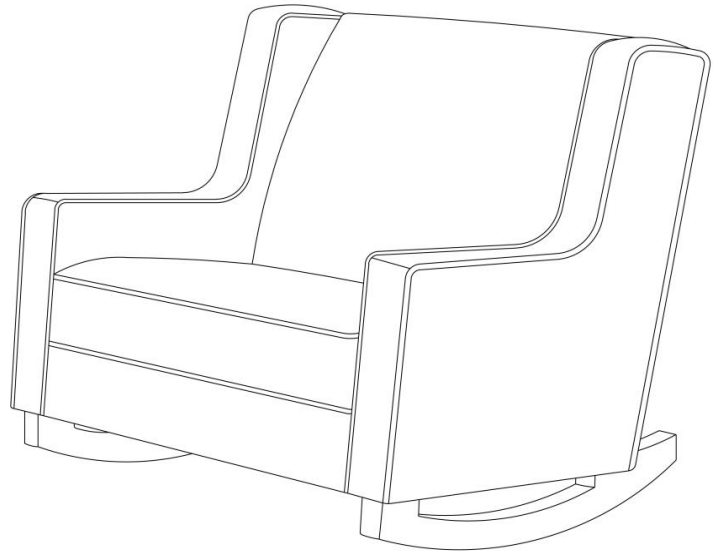

Congratulations! You've finished assembling your double rocker.

**DO NOT RETURN PRODUCT TO THE STORE.**

If a part is missing or damaged, contact our customer service department. We will replace the part **FREE** of charge.



**Tel #:** 1-800-295-1980  
**E-Mail:** [das@dorel.com](mailto:das@dorel.com)  
**Fax #:** 514-353-7819

# Customer Service

**PLEASE DO NOT RETURN THIS PRODUCT TO THE STORE**

**PLEASE CONTACT CUSTOMER SERVICE REPRESENTATIVES AT THE FOLLOWING NUMBERS SHOULD THERE BE ANY MISSING OR DEFECTIVE PART(S).**

Customer Service Phone Number 1-800-295-1980	Email: <a href="mailto:das@dorel.com">das@dorel.com</a>
Customer Service Fax Number 514-353-7819	

Request Date:

Name:

Shipping Address:

Street & Number:

City & State:

Zip Code:

Day Time Phone Number:

(including area code)

Date & Place of Purchase:

Part(s) description and quantity (Please be sure to list model number or SKN number):