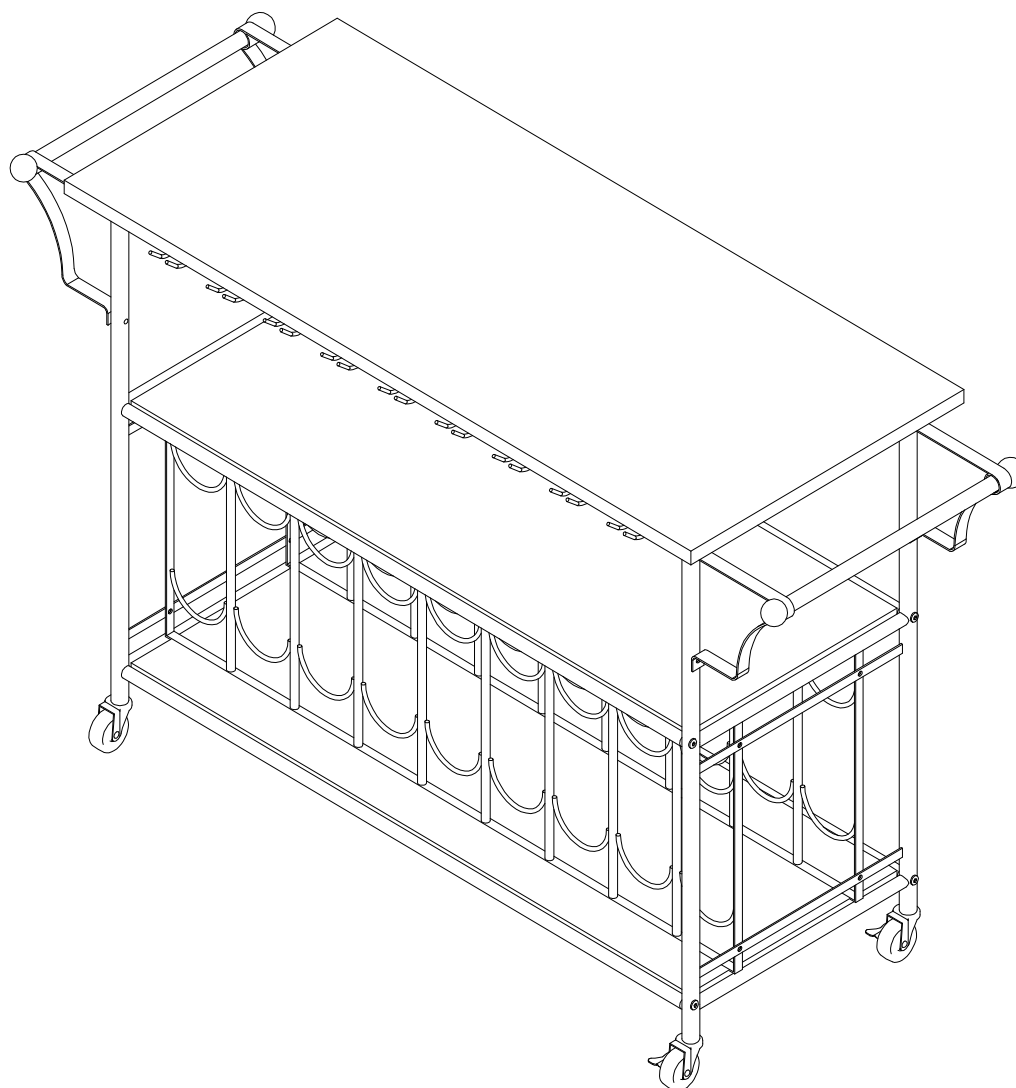


# HZ204700TX Wine Bar/Cart Assembly Instructions



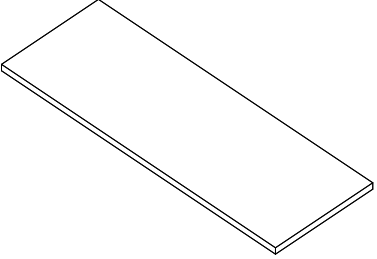
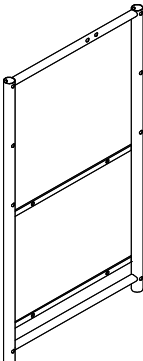
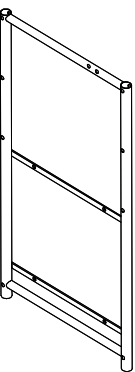
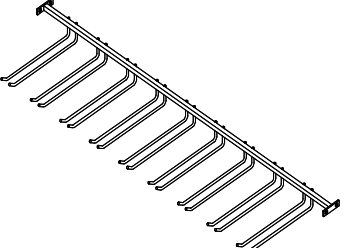
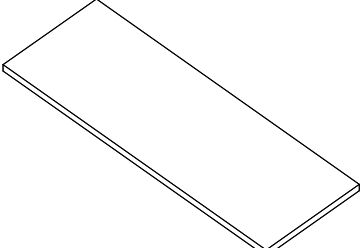
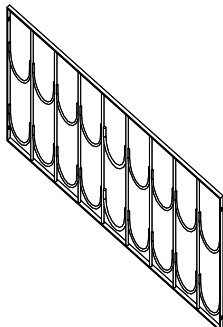
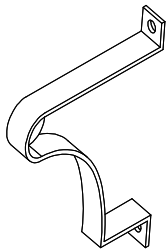
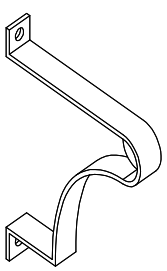
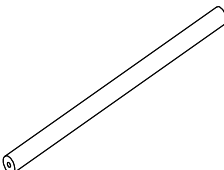
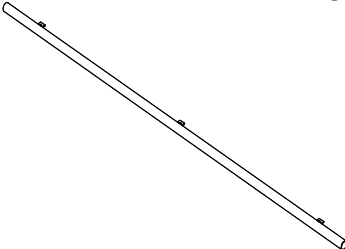
For assistance with assembly contact:  
Southern Enterprises Inc.  
Customer Service 1-800-633-5096  
[service@seidal.com](mailto:service@seidal.com)  
[www.seidal.com](http://www.seidal.com)

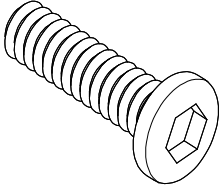
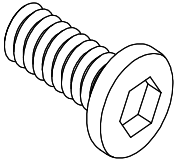
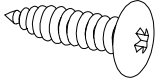
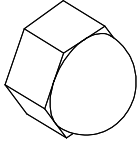
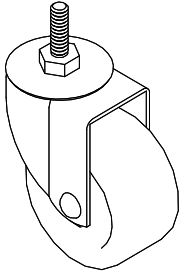
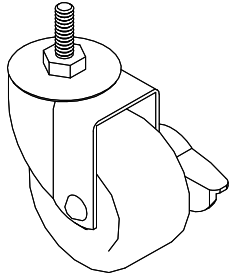
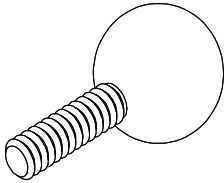

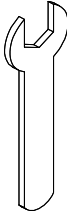
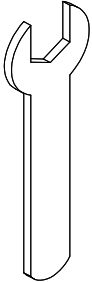
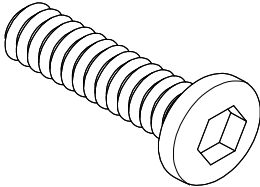
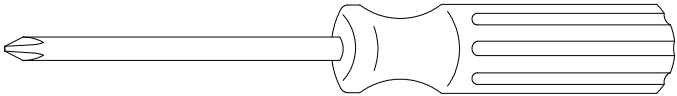


# HZ204700TX Wine Bar/Cart

## Parts List

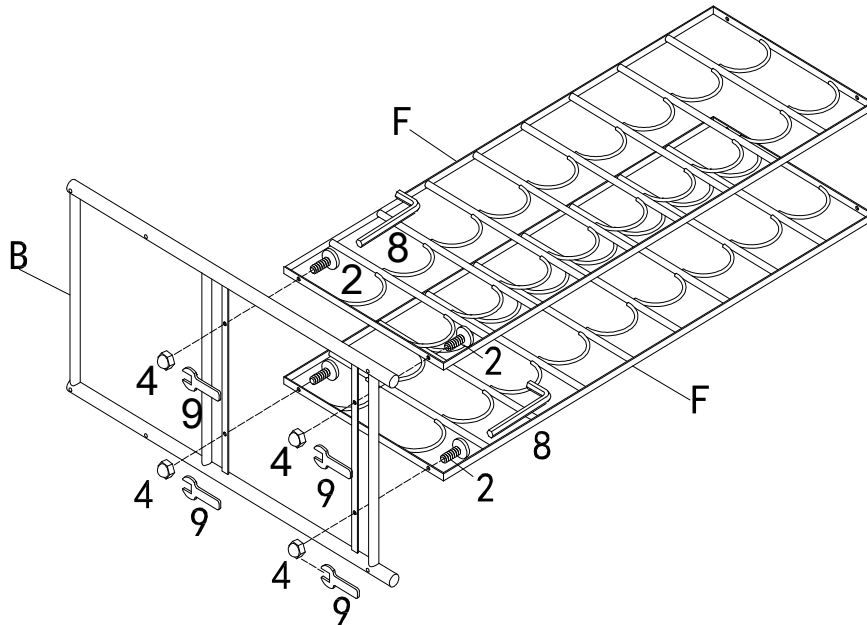
Please review all parts and hardware before disposing of any packaging. Call Customer Service if missing hardware. Do not return to store/retailer. Using a screw that is too long will cause damage. Before beginning assembly, separate each type of screw. Carefully study the screw diagrams below. You may receive extra hardware with your unit.

|  |  |  |
|--|--|--|
| <b>A.</b><br>Quantity<br>Of 1<br>   | <b>B.</b><br>Quantity<br>Of 1<br>   | <b>C.</b><br>Quantity<br>Of 1<br>   |
| <b>D.</b><br>Quantity<br>Of 1<br>  | <b>E.</b><br>Quantity<br>Of 2<br>  | <b>F.</b><br>Quantity<br>Of 2<br>  |
| <b>G.</b><br>Quantity<br>Of 2<br> | <b>H.</b><br>Quantity<br>Of 2<br> | <b>I.</b><br>Quantity<br>Of 2<br> |
| <b>J.</b><br>Quantity<br>Of 2<br> |  |  |

|   |  |  |
|---|--|--|
| <p>1. Quantity Of 12</p>  <p>Bolt: 1/4"*1-1/4"L</p>  | <p>2. Quantity Of 12</p>  <p>Bolt: 1/4"*1/2"L</p>     | <p>3. Quantity Of 18</p>  <p>Bolt: 1/4"*1/2"L</p>   |
| <p>4. Quantity Of 12</p>  <p>Nut</p>   | <p>5. Quantity Of 2</p>  <p>Caster</p>                | <p>6. Quantity Of 12</p>  <p>Caster with lock</p>   |
| <p>7. Quantity Of 4</p>  <p>Finial</p>   | <p>8. Quantity Of 1</p>  <p>Allen wrench</p>        | <p>9. Quantity Of 1</p>  <p>Small crescent wrench for nut</p>                                     |
| <p>10. Quantity Of 1</p>  <p>Large crescent wrench for caster</p>  | <p>11. Quantity Of 4</p>  <p>Bolt: 1/4"*1-1/2"L</p> |  |
| <p><b>Care and Cleaning Instructions:</b><br/>         Before using, wipe with a clean, dry cloth. Periodically apply furniture wax to renew the finish . Avoid rubbing or scratching the surface with rough or abrasive objects.</p> |  | <p>For replacement parts or questions, please Call Customer Service at 1-800-633-5096 Do not return product to store, please call Manufacturer for assistance, questions or Parts.</p> |
| <p><b>Assembly Tool Required No.2 Phillips Screwdriver (Not Included)</b></p>   |  |    |

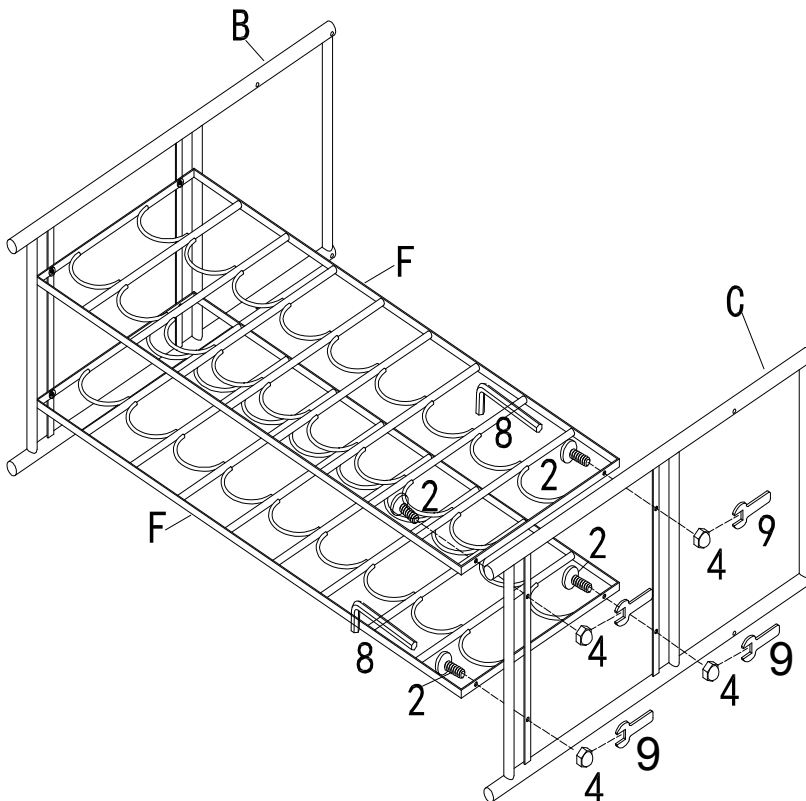
# HZ204700TX Wine Bar/Cart

## Assembly Instructions



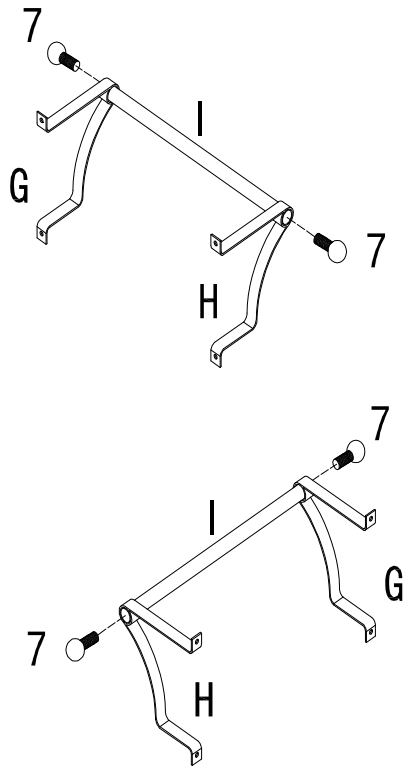
**Figure 1**

Insert Bolts (2) through pre-drilled holes on wine holder (F) .  
Attach left side frame (B) to wine holder (F) using nut (4) and bolts (2) and small crescent wrench (9), allen wrench (8) as shown.



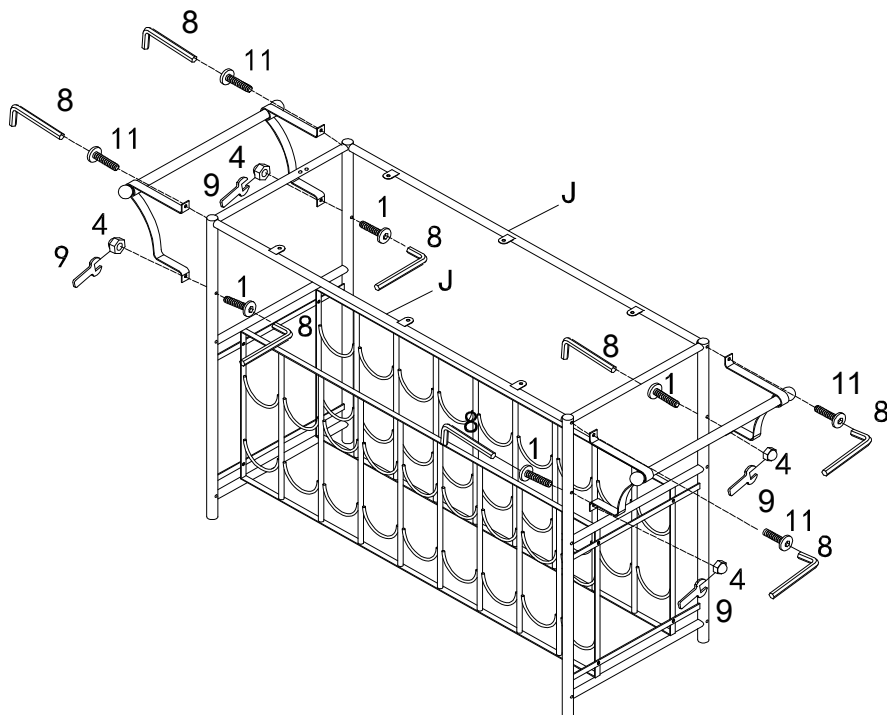
**Figure 2**

Repeat with right side frame (c) to wine holder (F) to be same as figure 1 way



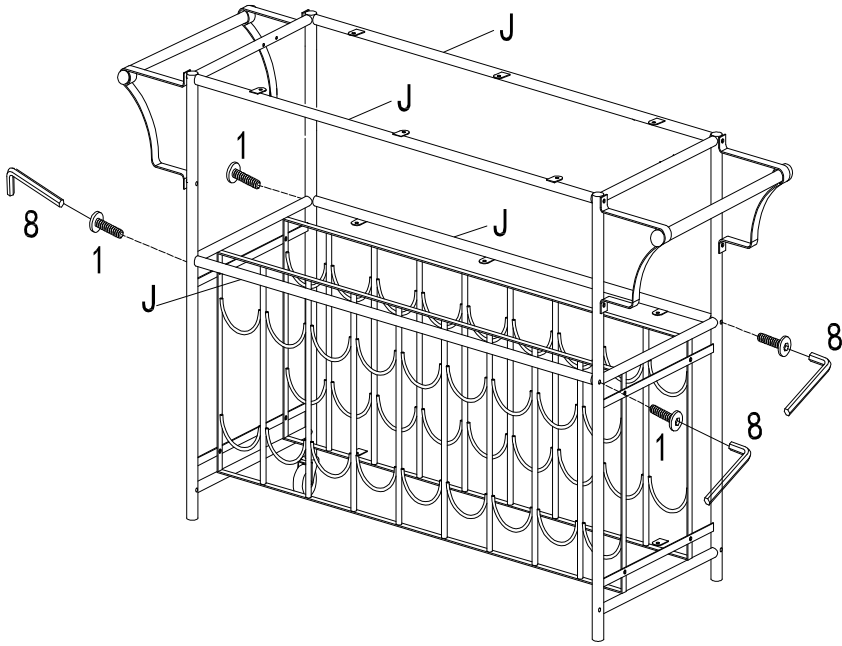
Attach Left arm support (G) and right arm support (H) to short bar (I) using Finial (7).

**Figure 3**



Attach unit figure 3 and long tube (J) to unit figure 2 using bolt (11) (1) and Allen wrench (8) and nut (4) and Small crescent wrench (9).

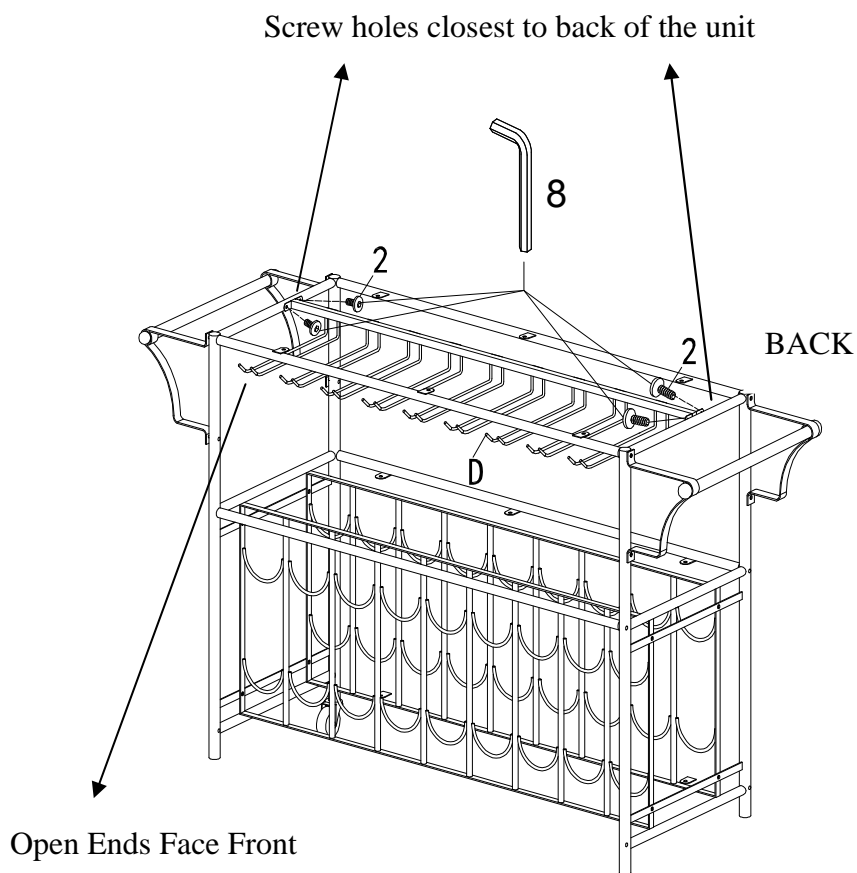
**Figure 4**



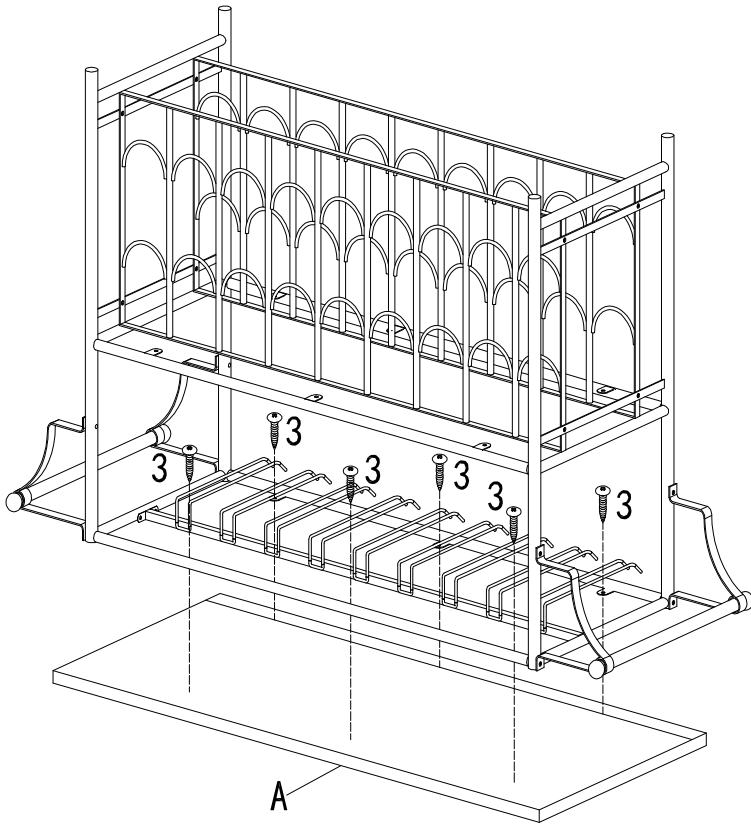
Attach long tube(J) to side frame in middle using bolts (1) and allen wrench (8).

**Figure 5**

Attach glass rack (D) (WITH OPEN ENDS FACING FRONT) using bolts (2) and allen wrench (8).

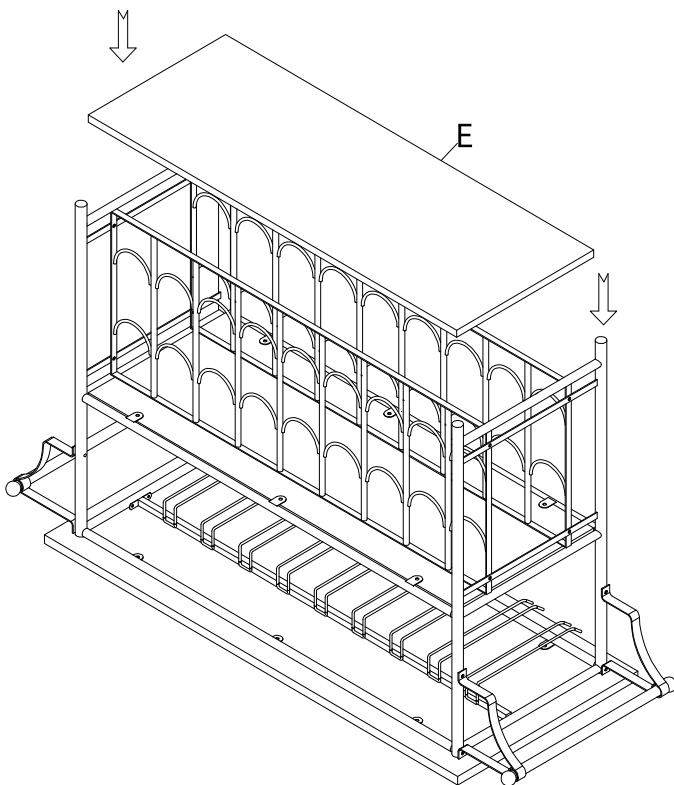


**Figure 6**



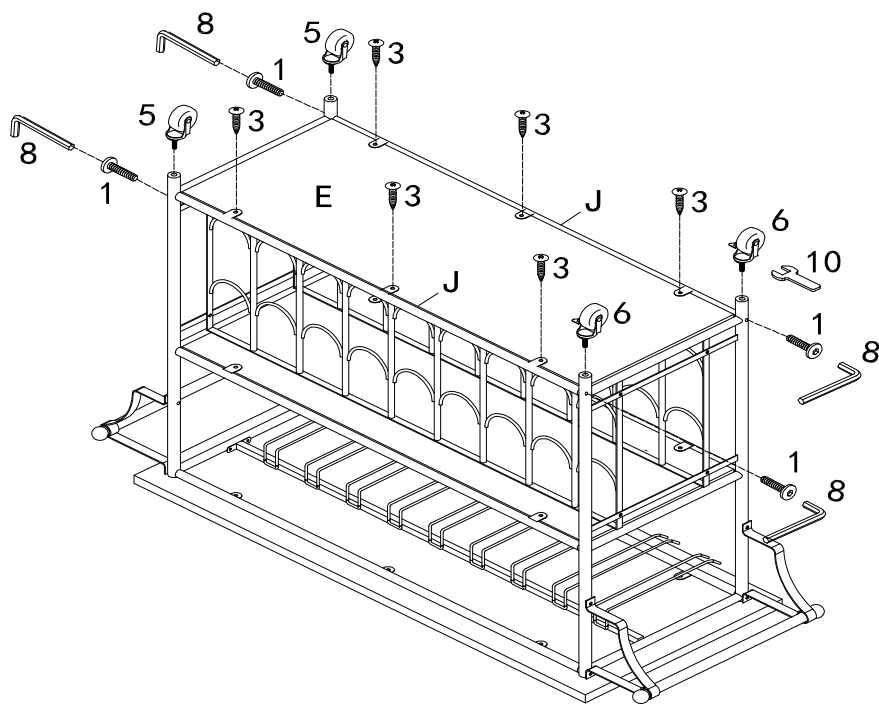
**Figure 7**

Turn unit from figure 6 upside down. Attach pre-assembled parts on figure 6 to top panel (A) using screw (3).



**Figure 8**

Put shelf (E) on bottom of wine bottle rack.



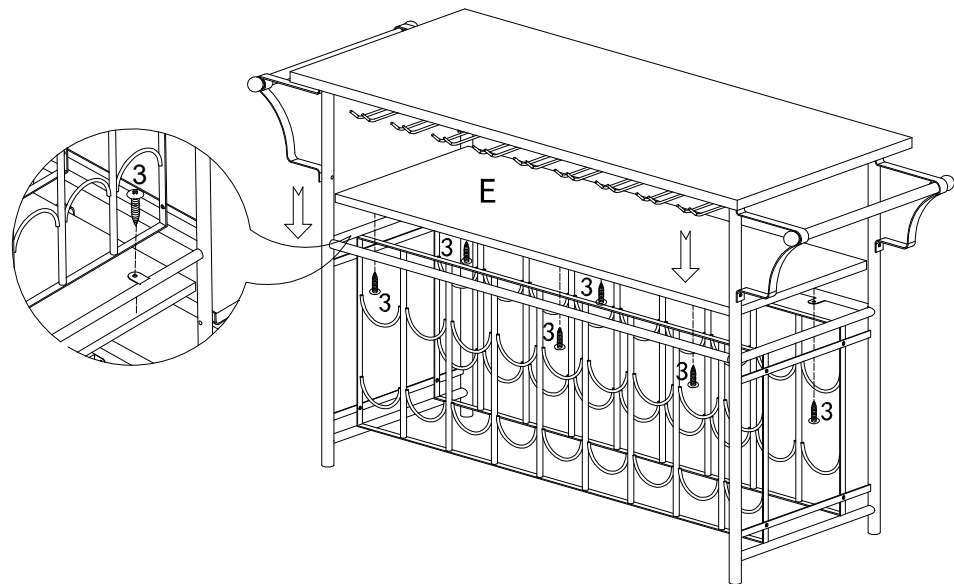
Attach long tube (J) to bottom of side frame (B) using bolt (1) and allen wrench (8).

Attach shelf (E) on bottom of metal bars using wood screw (3).

Attach caster (5) and caster with lock (6) using crescent wrench (10)

**Figure 9**

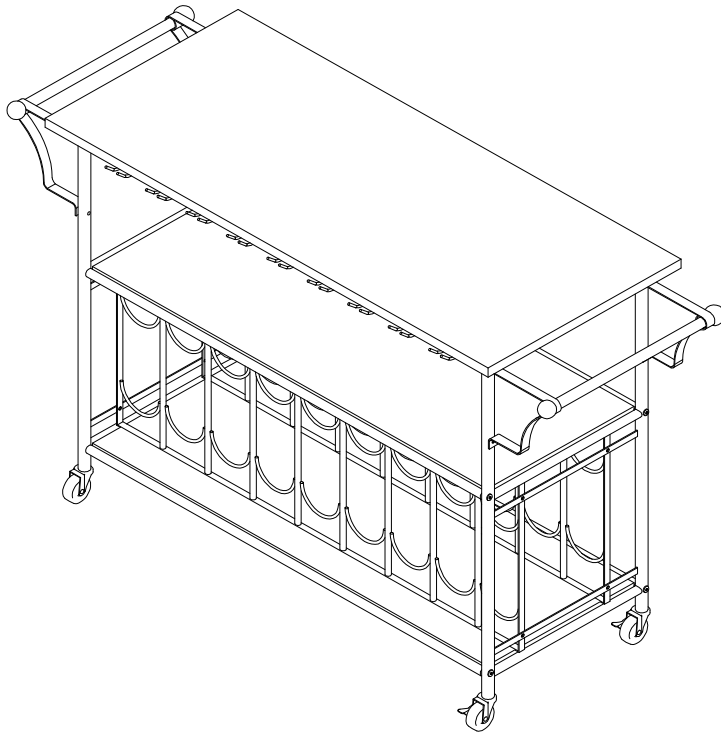
Attach shelf (E) to the middle of unit using wood screw (3)



**Figure 10**



**Now your wine bar/cart is ready to use.**



**Figure 11**

# Parts Replacement Form

## Customer Information

Name \_\_\_\_\_

Address \_\_\_\_\_

City/State/Zip Code \_\_\_\_\_

Phone Number \_\_\_\_\_

Please indicate where you purchased this item: Store/Website/Catalog

Please indicate color/size/style number:

| Style No | Parts Letter | Parts Description | Quantity Needed |
|----------|--------------|-------------------|-----------------|
| _____    | _____        | _____             | _____           |
| _____    | _____        | _____             | _____           |
| _____    | _____        | _____             | _____           |

Please immediately examine this product carefully. Any request for missing parts or damage replacement must be received within 90 days of your receipt of the product. Replacement, if available, will be honored within this time frame. Parts will not be available for items arriving fully assembled. We do not recommend modifying product(s) and we are not responsible for any damages due to product modification(s). If damages or missing parts are not reported within 90 days of your receipt, we are under no obligation to provide parts or replacement merchandise.

Please contact Southern Enterprises at 800-633-5096 or in Dallas 972-869-0111/ 9am – 4pm Mon-Fri Central time if you have product issues or email us at [service@seidal.com](mailto:service@seidal.com). Please ask for customer service representative for issues involving damages or replacement parts. Please ask for technical assistance representative for any issues with product and assembly/construction.

Please contact the retailer that you purchased from for returns.



Customer Service 1-800-633-5096  
[service@seidal.com](mailto:service@seidal.com)  
Southern Enterprises, Inc.  
600 Freeport Parkway, Suite 200  
Coppell, Texas 75019