



ACTIVATE YOUR WARRANTY

by registering your product:
championpowerequipment.com

SERIAL NO.



 **1-877-338-0999**

or visit championpowerequipment.com

SAVE THESE INSTRUCTIONS. This manual contains important safety precautions which should be read and understood before operating the product. Failure to do so could result in serious injury. This manual should remain with the product.

Specifications, descriptions and illustrations in this manual are as accurate as known at the time of publication, but are subject to change without notice.

TABLE OF CONTENTS	
Introduction	3
Safety Definitions	3
Important Safety Instructions	4
Fuel Safety	5
Safety and Dataplate Labels	7
Safety Symbols	9
Operation Symbols	11
Quick Start Label Symbols	11
Controls and Features	12
Lawn edger	12
Parts Included	13
Tools Needed	14
Parts Not Included	14
Assembly	15
Unpacking	15
Wheel Assembly	15
Assemble the Handle	16
Assemble the Control Rod	16
Connect the Engine Ground Wires	16
Assemble the Recoil Rope Guide	17
Operation	17
Add Engine Oil	17
Add Fuel	18
Starting the Engine	19
Stopping the Engine	20
Lawn Edger Operation	20
Adjust the Edging Depth	20
Adjust the Blade Bevel Angle	21
Operate the Curb Hop Feature	21
Maintenance	22
Cleaning the Lawn Edger	23
Engine Oil Services	23
Cleaning and Adjusting the Spark Plug(s)	24
Cleaning the Air Filter	24
Changing the Blade	25
Replace the Belt	25
Adjusting the Governor	25
Maintenance Schedule	25
Storage	26
Short Term Engine Storage (Up to 30 Days)	26
Long Term Engine Storage (30 Days – 1 Year)	26
Specifications	27
Lawn Edger Specifications	27
Engine Specifications	27
Oil Specifications	27
Fuel Specifications	27
Temperature Specifications	27
Troubleshooting	28

 **FOR PARTS BREAKDOWN**

Search by model number at
championpowerequipment.com

INTRODUCTION

Congratulations on your purchase of a Champion Power Equipment (CPE) product. CPE designs, builds, and supports all of our products to strict specifications and guidelines. With proper product knowledge, safe use, and regular maintenance, this product should bring years of satisfying service.

Every effort has been made to ensure the accuracy and completeness of the information in this manual at the time of publication, and we reserve the right to change, alter and/or improve the product and this document at any time without prior notice.

CPE highly values how our products are designed, manufactured, operated, and serviced as well as providing safety to the operator and those around the lawn edger. Therefore, it is **IMPORTANT** to review this product manual and other product materials thoroughly and be fully aware and knowledgeable of the assembly, operation, dangers and maintenance of the product before use. Fully familiarize yourself, and make sure others who plan on operating the product fully familiarize themselves too, with the proper safety and operation procedures before each use. Please always exercise common sense and always err on the side of caution when operating the product to ensure no accident, property damage, or injury occurs. We want you to continue to use and be satisfied with your CPE product for years to come.

When contacting CPE about parts and/or service, you will need to supply the complete model and serial numbers of your product. Transcribe the information found on your product's nameplate label to the table below

CPE TECHNICAL SUPPORT TEAM
1-877-338-0999
MODEL NUMBER
201465
SERIAL NUMBER
DATE OF PURCHASE
PURCHASE LOCATION

SAFETY DEFINITIONS

The purpose of safety symbols is to attract your attention to possible dangers. The safety symbols, and their explanations, deserve your careful attention and understanding. The safety warnings do not by themselves eliminate any danger. The instructions or warnings they give are not substitutes for proper accident prevention measures.

DANGER

DANGER indicates a hazardous situation which, if not avoided, will result in death or serious injury.

WARNING

WARNING indicates a hazardous situation which, if not avoided, could result in death or serious injury.

CAUTION

CAUTION indicates a hazardous situation which, if not avoided, could result in minor or moderate injury.

NOTICE

NOTICE indicates information considered important, but not hazard-related (e.g., messages relating to property damage).

IMPORTANT SAFETY INSTRUCTIONS

⚠ WARNING

Cancer and Reproductive Harm – www.P65Warnings.ca.gov

⚠ DANGER

Lawn edger exhaust contains carbon monoxide, a colorless, odorless, poisonous gas. Breathing carbon monoxide will cause nausea, dizziness, fainting or death. If you start to feel dizzy or weak, get to fresh air immediately.

OPERATE THE LAWN EDGER OUTDOORS ONLY IN A WELL VENTILATED AREA AND POINT EXHAUST AWAY.

NEVER operate the lawn edger inside any building, including garages, basements, sheds or other confined spaces.

DO NOT allow exhaust fumes to enter a confined area through windows, doors, vents or other openings while operating the edger.

⚠ DANGER

Using an engine indoors **CAN KILL YOU IN MINUTES**. Engine exhaust contains carbon monoxide. This is a poison you cannot see or smell.

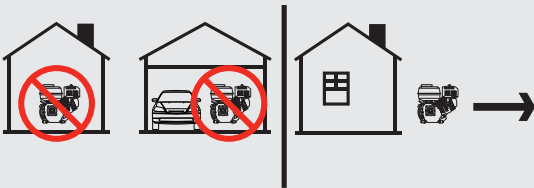

⚠ DANGER

DO NOT allow untrained individuals or children to use this unit.

⚠ DANGER

Rotating parts can entangle hands, feet, hair, clothing and/or accessories. Traumatic amputation or severe laceration can result.

Keep hands and feet away from rotating parts.

Tie up long hair and remove jewelry.

Operate equipment with guards in place.

DO NOT wear loose-fitting clothing, dangling drawstrings or items that could become caught.

⚠ WARNING

- Clear the work area before each use. Remove all objects such as rocks, broken glass, nails, wire, or string which can be thrown or become entangled in the machine.
- Always wear eye protection with side shields marked to comply with ANSI Z87.1. Failure to do so could result in objects being thrown into your eyes and other possible serious injuries.
- Keep all bystanders, children, and pets at least 50' (15m) away when operating the lawn edger.
- Always wear sound protection (ear muffers or ear plugs) to reduce the risk of hearing loss associated with long term engine sound level(s).
- Always wear heavy long pants, boots, gloves, and a long-sleeve shirt. Do not wear loose clothing, jewelry, short pants, sandals, or go barefoot. Secure long hair so it is above shoulder level to prevent entanglement in rotating parts.
- Do not operate this unit when you are tired, ill, or under the influence of alcohol, drugs, or medication.
- Do not operate in poor lighting.
- Always wear a face filter mask in dusty conditions to reduce the risk of injury associated with the inhalation of dust.
- Keep firm footing and balance. Maintain a firm grip on the handle with both hands while using the edger.
- Do not overreach. Overreaching can result in loss of balance or exposure to hot contact surfaces or rotating parts.
- Always inspect the unit before each use for loose fasteners, fuel leaks, etc. Replace damaged parts.
- Use only identical manufacturer's replacement parts and accessories. Use of any other replacement parts may create a hazard or cause product damage and void your warranty.
- Maintain the equipment per maintenance instructions located in this Operator's Manual

⚠ DANGER

Rotating blades can cause severe bodily injury. Stop the engine and ensure blades have stopped rotating before installing/ changing parts or performing maintenance.

⚠ WARNING

Sparks can result in fire or electrical shock.

When servicing the lawn edger:

Disconnect the spark plug wire and place it where it cannot contact the plug or any other metal object.

DO NOT check for spark with the plug removed.

Use only approved spark plug testers.

⚠ WARNING

Running engines produce heat. Severe burns can occur on contact. Combustible material can catch fire on contact.

DO NOT touch hot surfaces.

Avoid contact with hot exhaust gases.

Allow equipment to cool before touching.

Maintain at least 3 ft. (91.4 cm) of clearance on all sides to ensure adequate cooling.

Maintain at least 5 ft. (1.5 m) of clearance from combustible materials.

⚠ WARNING

Rapid retraction of the recoil cord will pull hand and arm towards the engine faster than you can let go. Broken bones, fractures, bruises or sprains could result. Unintentional startup can result in entanglement, traumatic amputation or laceration.

When starting engine, pull the recoil cord slowly until resistance is felt and then pull rapidly to avoid kickback.

⚠ CAUTION

Prolonged exposure to vibrations, also known as vibration white finger, through use of gasoline-powered equipment, such as this edger, could cause blood vessel or nerve damage in fingers, hands, and joints. If symptoms occur such as numbness, or loss of feeling in the fingers, hands, or joints, discontinue the use of this edger and seek medical attention.

Fuel Safety**⚠ DANGER**

GASOLINE AND GASOLINE VAPORS ARE HIGHLY FLAMMABLE AND EXPLOSIVE.

Fire or explosion can cause severe burns or death.

Gasoline and gasoline vapors:

- Gasoline is highly flammable and explosive.
- Gasoline can cause a fire or explosion if ignited.
- Gasoline is a liquid fuel but it's vapors can ignite.
- Gasoline is a skin irritant and needs to be cleaned up immediately if spilled on skin or clothes.
- Gasoline has a distinctive odor, this will help detect potential leaks quickly.
- Gasoline expands or contracts with ambient temperatures. Never fill the gasoline tank to full capacity, as gasoline needs room to expand when temperatures rise.
- In the case of any petroleum gasoline fire, flames should never be extinguished unless the fuel supply valve can be turned OFF. By not doing so, if a fire is extinguished and the supply of fuel is not turned OFF, an explosion hazard could be created.

⚠ WARNING**When adding or removing gasoline:**

DO NOT light or smoke cigarettes while handling gasoline.

Always store or transfer gasoline in an EPA/CARB compliant fuel tank.

Never pump gasoline directly into the lawn edger at the gas station.

Always drain gasoline outdoors in a well-ventilated area.

Always loosen fuel cap slowly to release vapor pressure and to keep fuel from escaping around the fuel cap.

Always replace and tighten the fuel cap securely after fueling.

Always stop the engine and allow to cool for a minimum of two minutes before refueling.

Never remove the fuel cap or add fuel while the engine is running or when the engine is hot.

DO NOT overfill the gasoline tank.

In the event of spilled fuel, wipe the fuel from the lawn edger and move 10 ft. (3m) away from refueling site before starting the engine to avoid potential ignition of fuel vapors.

Save these instructions. Refer to them frequently and use them to instruct others who may use this product. If you loan this equipment, provide these instructions also.

⚠ WARNING**When starting the lawn edger:**

DO NOT attempt to start a damaged lawn edger.

Always check that the gasoline cap, air filter, spark plug, fuel lines and exhaust system are properly in place.

Always be certain that the lawn edger is resting firmly on level ground.

⚠ WARNING**When operating the lawn edger:**

DO NOT move or tip the lawn edger during operation.

⚠ WARNING**When transporting or servicing the lawn edger:**

Always check that the fuel valve is in the OFF position and the gasoline tank is empty.

Disconnect the spark plug wire.

⚠ WARNING**When storing the lawn edger:**

Always store gasoline in a cool, well-ventilated area, safely away from sparks, open flames, pilot lights, heat and other sources of ignition.

⚠ DANGER

Never place a gasoline container, gasoline tank, LPG cylinder or any combustible material in the path of the exhaust stream during operation of the engine.

⚠ WARNING





Never use a gasoline container, gasoline tank, or any other fuel item that is broken, cut, torn or damaged.

Safety and Dataplate Labels

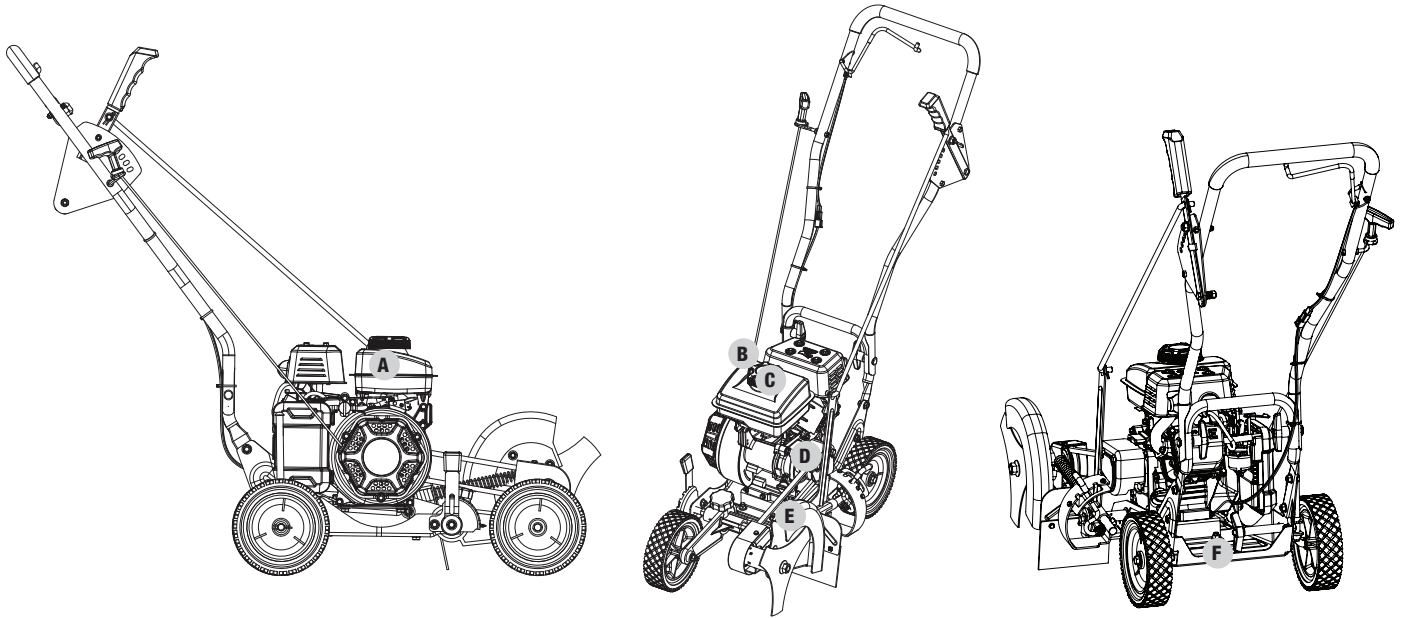
These labels warn you of potential hazards that can cause serious injury. Read them carefully.

If a label comes off or becomes hard to read, contact Technical Support Team for possible replacement.

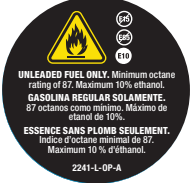



	LABEL	DESCRIPTION
A		Engine Danger Icon
B		Hot Surface Warning
C		Fuel Requirements
D		Danger Rotating Parts
E		Blade Guard Danger Rotating Parts – Thrown Objects

	LABEL	DESCRIPTION
F	 <p>CHAMPION POWER EQUIPMENT, INC. 6370 S PIONEER WAY, UNIT 101, LAS VEGAS NV 89113, USA / É.-U. 1-877-338-0999 WWW.CHAMPIONPOWEREQUIPMENT.COM</p> <p>MANUFACTURED TO MEET ANSI B71.6-2000</p> <p>8 17198 02808 8</p> <p>MODEL MODELE 201465</p> <p>SERIAL NO. N° DE SÉRIE XXXXXXXXXXXXX</p> <p>REGISTER TO ACTIVATE YOUR WARRANTY ENREGISTREZ-VOUS POUR ACTIVER VOTRE GARANTIE</p>	Dataplate

Safety Symbols

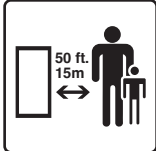

Some of the following symbols may be used on this product. Please study them and learn their meaning. Proper interpretation of these symbols will allow you to more safely operate the product.



SYMBOL	MEANING
	<p>Read Operator's Manual. To reduce the risk of injury, user must read and understand operator's manual before using this product.</p>
	<p>Eye and Ear Protection. Always wear safety goggles or safety glasses with side shields, and as necessary a full face-shield as well as full ear protection when operating this product.</p>
	<p>Footwear. Always wear safety shoes or heavy boots when operating the machine.</p>
	<p>Gloves. Always wear nonslip, heavy-duty protective gloves when operating this product.</p>
	<p>Safety Alert. Precautions that involve your safety.</p>
	<p>Risk of Fire. Fuel and its vapors are extremely flammable and explosive. Fire can cause severe burns or death. Do not add fuel while the product is operating or still hot.</p>
	<p>Hot Surface. To reduce the risk of injury or damage, avoid contact with any hot surface</p>
	<p>Open Flame alert. Fuel and its vapors are extremely flammable and explosive. Keep fuel away from smoking, open flames, sparks, pilot lights, heat, and other ignition sources.</p>

SYMBOL	MEANING
	<p>Toxic Fumes. The engine exhaust from this product contains chemicals known to the state of California to cause cancer and birth defects and other reproductive harm.</p> <p>Risk of Asphyxiation. This engine emits carbon monoxide, an odorless, colorless poison gas. Breathing carbon monoxide can cause nausea, fainting or death. Use only in a well ventilated area.</p>
	<p>Clearance. Keep all objects including others at least 50 feet (15m) from this machine.</p>
	<p>Amputation Hazard. Rotating parts can entangle hands, feet, hair, clothing and/or accessories. Traumatic amputation or severe laceration can result.</p>
	<p>Thrown Objects. This machine may pick up and throw objects which can cause personal injury. Check the work area before each use. Remove all objects such as rocks (where possible), broken glass, nails, wire, or string which can be thrown or become entangled in the machine.</p>

Operation Symbols

Some of the following symbols may be used on this product. Please study them and learn their meaning. Proper interpretation of these symbols will allow you to more safely operate the product.

SYMBOL	MEANING
	Fuel Valve : ON
	Fuel Valve : OFF
	Choke

SYMBOL	MEANING
	Run
	Blade depth adjustment

Quick Start Label Symbols

Some of the following symbols may be used on this product. Please study them and learn their meaning. Proper interpretation of these symbols will allow you to more safely operate the product.



Starting the Engine

1. **Check oil level.**
Recommended oil is 10W-30.
2. **Check gasoline level.**
When adding gasoline, use a minimum octane rating of 87 and an ethanol content of 10% or less by volume.
3. Move the **depth control lever** to the “START” position.
4. Rotate the **fuel valve** to the “ON” position.
5. Move the **choke lever** to the “CHOKE” position.
6. Engage the **control lever**.
7. Pull the **recoil starter**.
8. Move the **choke lever** to the “RUN” position.

Stopping the Engine

1. Release the **control lever**.
2. Rotate the **fuel valve** to the “OFF” position.

CONTROLS AND FEATURES

Read this operator's manual before operating your lawn edger. Familiarize yourself with the location and function of the controls and features. Save this manual for future reference.

Lawn edger

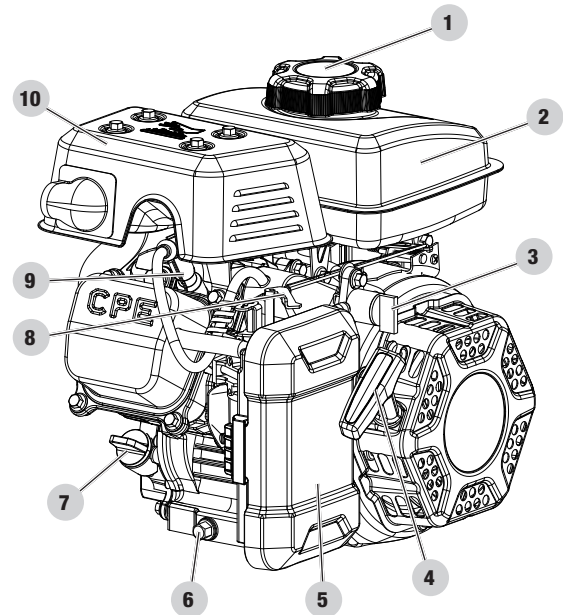
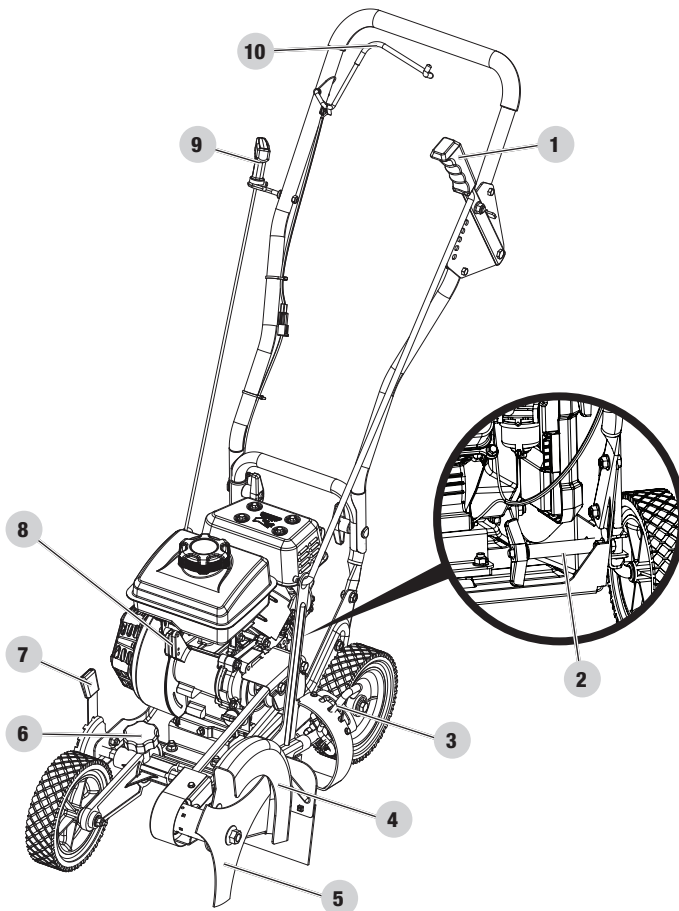

Edger

1. Blade/Edging Depth Adjuster
2. Rear Wheel Cub Hop Adjustment
3. Blade/Edging Bevel Adjustment
4. Blade Guard
5. Blade
6. Front Wheel Lateral Adjustment
7. Front Wheel Curb Hop Adjustment
8. Engine
9. Recoil Starter
10. Control Lever

Engine

1. Fuel Tank Cap
2. Fuel Tank
3. Fuel Valve
4. Recoil Starter
5. Air Filter
6. Oil Drain Bolt
7. Oil Fill Cap/Dipstick
8. Choke
9. Spark Plug
10. Muffler

Parts Included

Assembly Parts

Part	Part Qty.	Hardware Needed	Hardware Qty.	Tool Needed
Front wheel	1	M8 x 76 Hexagon bolt	1	13mm Wrench
		Flat washer Ø8.5 x Ø17.7 x 1.4	3	N/A
		Spacer, sleeve	1	N/A
		M8 Flange lock nut	1	12mm Wrench
Left rear wheel	1	Hexagon flange bolt, shoulder	1	14mm Wrench
		Spacer, sleeve	1	N/A
		Ø10 x Ø32 x 3 Flat washer	1	N/A
		M10 nut	1	14mm Wrench
Right rear wheel	1			N/A
Rope guide	1	Nylon lock nut, 1/4-20	1	10mm Wrench
Depth control rod	1	R-Pin	2	N/A
Upper handle	1	Tubular bolt	2	N/A
		Wing knob	2	N/A

Accessories

- Engine Oil..... 13.5 fl. Oz. (400 ml)
- Engine Oil Funnel..... 1
- Spark Plug Wrench..... 1

Tools Needed

- Metric Wrench or Socket Set
- Phillips Screwdriver
- Pliers

Parts Not Included

- Metric Wrench or Socket Set

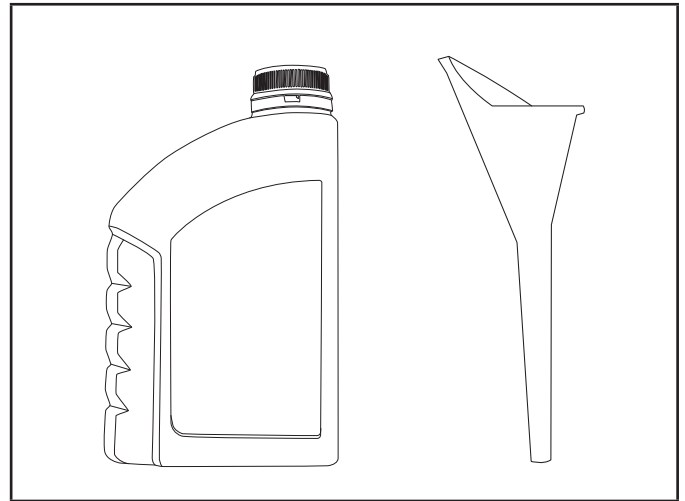

ASSEMBLY

Your lawn edger requires some assembly. This unit ships from our factory without oil. It must be properly serviced with fuel and oil before operation.

If you have any questions regarding the assembly of your lawn edger, call our Technical Support Team at 1-877-338-0999. Please have your serial number and model number available.

Unpacking

1. Set the shipping carton on a solid, flat surface.
2. Remove all contents from the carton.

Wheel Assembly

Assemble the Front Wheel

1. Install a $\varnothing 8.5 \times \varnothing 17.7 \times 1.4$ flat washer onto the M8 x 76 hex bolt then install the spacer sleeve onto the hex bolt.
2. Insert the hex bolt with washer and spacer sleeve through the center hole of the wheel.
3. Install a $\varnothing 8.5 \times \varnothing 17.7 \times 1.4$ flat washer onto the hex bolt.
4. Insert the end of the hex bolt through the mounting hole on the lawn edger frame.
5. Install a $\varnothing 8.5 \times \varnothing 17.7 \times 1.4$ flat washer onto the end of the hex bolt then thread the M8 flange lock nut onto the hex bolt and tighten securely using a 13 mm hex wrench and a 12 mm wrench or socket.



Assemble the Right Rear Wheel

1. Loosen the rear wheel locking knob by rotating it counterclockwise.
2. Insert the rod on the rear wheel through the mounting bracket on the frame and fully seat the wheel into place.
3. Secure the rear wheel into place by rotating the rear wheel locking knob clockwise until it is fully tightened.

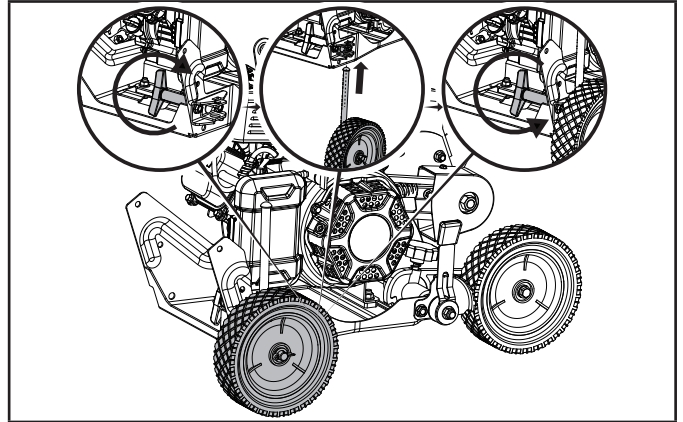

Assemble the Left Rear Wheel

1. Insert the hex flange shoulder bolt through the center hole of the wheel.
2. On the back side of the wheel, install the spacer sleeve on to the shoulder bolt then install the $\varnothing 10 \times \varnothing 32 \times 3$ flat washer onto the shoulder bolt.
3. Insert the end of the shoulder bolt through the mounting hole on the lawn edger frame.
4. Thread the M10 nut onto the shoulder bolt and tighten securely using a 14mm wrench or socket.

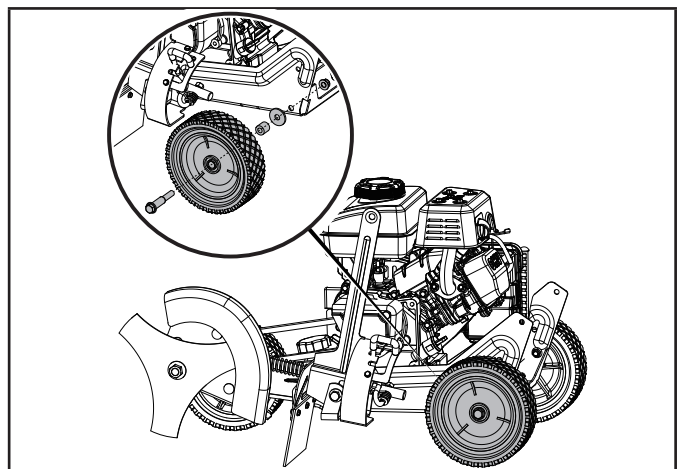

Assemble the Handle

1. Slide the upper handle tubes down onto the lower handle tubes and align the holes on the upper handle with the holes on the lower handle.
2. On each side of the handle, from the outside, insert a tube bolt through the holes on both the upper and lower handle tubes.
3. Thread a wing knob onto each tube bolt and tighten securely by hand.

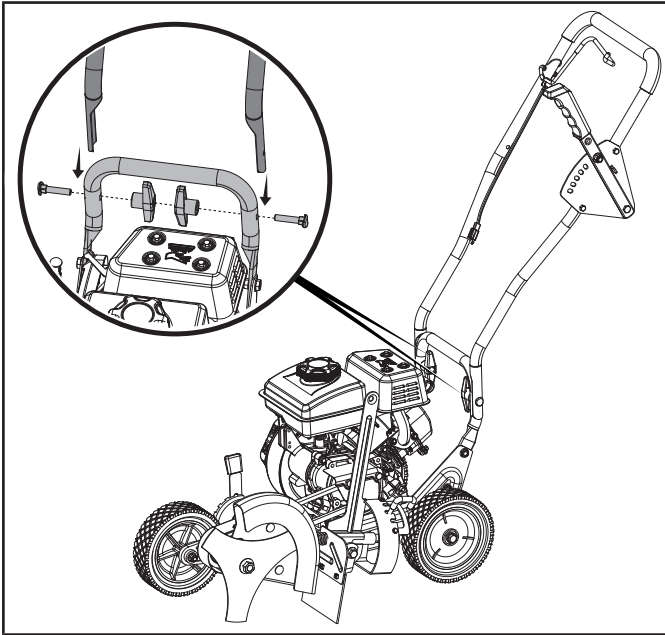

Assemble the Control Rod

1. Insert one end of the control rod through the hole on the depth adjust lever and secure it in place using the R-clip.

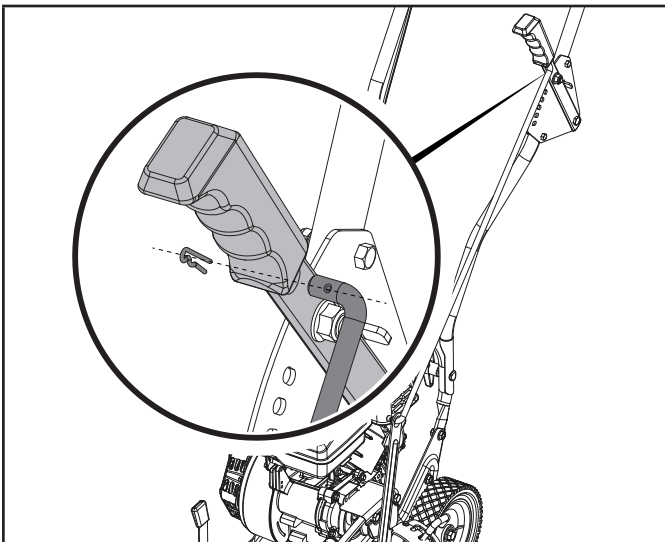

2. Insert the other end of the control rod through the hole on the blade adjust arm and secure it in place using the R-clip.

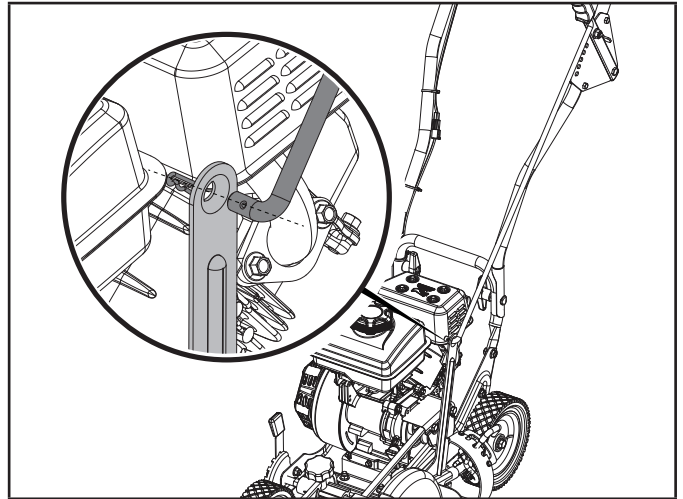

Connect the Engine Ground Wires

1. Remove the temporary inset from the ground wire terminal that is coming from the engine.

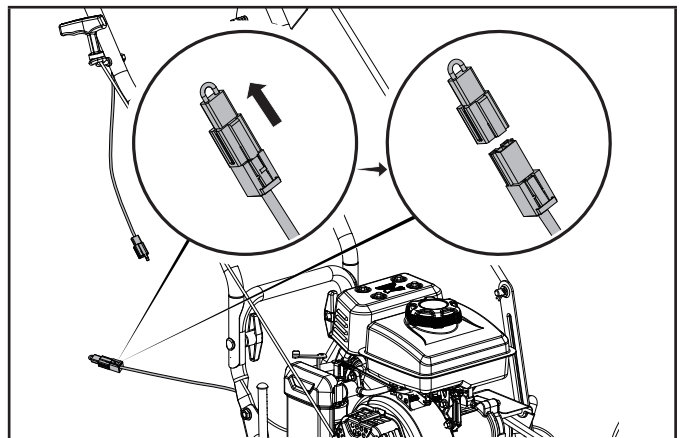

2. Connect the engine ground wire to the handle ground wire.

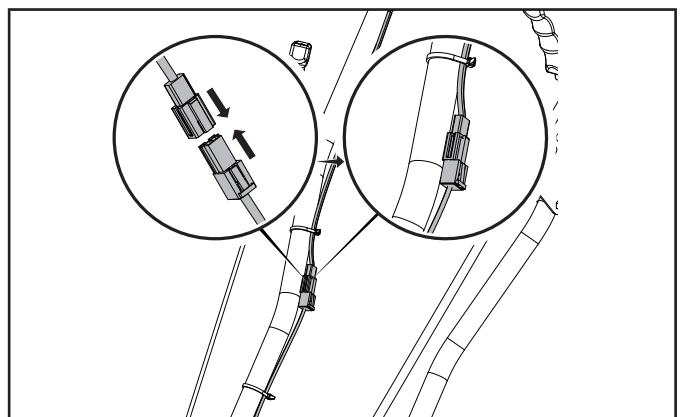

Assemble the Recoil Rope Guide

1. Insert the rope guide through the hole on the upper handle.
2. Thread the ¼ - 20 nylon lock nut onto the rope guide and tighten securely using a 10 mm wrench or socket.
3. Slowly pull the recoil handle up to the rope guide and twist the rope into position on the guide placing the recoil handle in the correct starting position.

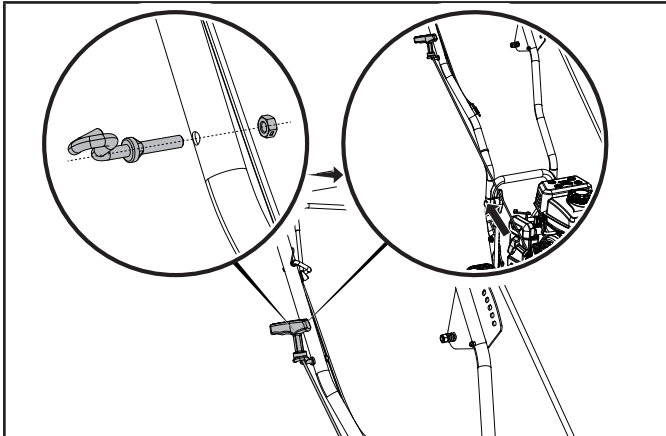

OPERATION

Add Engine Oil

⚠ WARNING

DO NOT attempt to crank or start the engine before it has been properly filled with the recommended type and amount of oil. Damage to the lawn edger as a result of failing to follow these instructions will void your warranty.

🗨 NOTICE

The recommended oil type for typical use is **10W-30 automotive oil**. However, using the listed conventional oils shown in the “Recommended Engine Oil Type” chart may be used for typical use including the first 5 hours of the break-in run time period of the engine.

If running lawn edger in extreme temperatures, refer to the “Recommended Engine Oil Type” chart.

Recommended Engine Oil Type	
°F	-20 0 20 40 60 80 100 120
°C	-28.9 -17.8 -6.7 4.4 15.6 26.7 37.8 48.9
Ambient temperature	

1. Place the Lawn Edger on a flat, level surface.
2. Remove oil fill cap/dipstick and, using a funnel, add up to 11.8 fl. oz. (350 ml) of oil (included) and replace oil fill cap/dipstick. **DO NOT OVERFILL.**

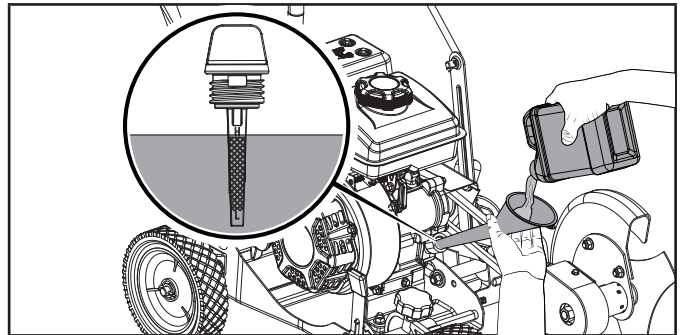

3. Insert the oil fill cap into the oil filler neck and seat it in place
4. Remove the oil fill cap/dipstick and check the oil level. The oil level should be at or near the OIL FILL mark on the dip stick.
5. Check engine oil level before every use and add as needed.

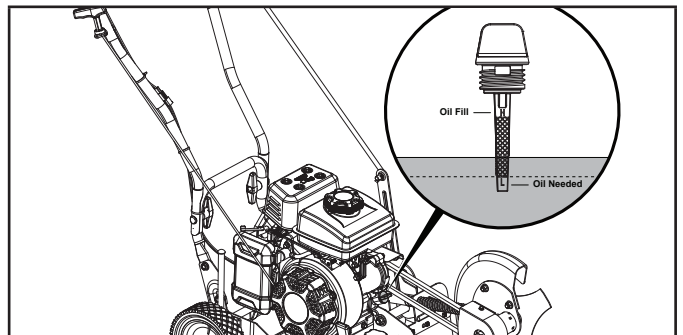

🗨 NOTICE

Once oil has been added, a visual check should show oil about 1-2 threads from running out of the fill hole.

When using the dipstick to check oil level, **DO NOT** screw in the dipstick while checking.

🗨 NOTICE

Check oil level often during the break-in period. Refer to the Maintenance section for recommended service intervals.

⚠ CAUTION

The engine is equipped with a low oil shut-off and will stop when the oil level in the crankcase falls below the threshold level.

NOTICE

The first 5 hours of run time is the break-in period for the engine. During the break in period, it is recommended to use standard automotive, non-synthetic blended oils. Adjusting throttle setting will increase/ decrease engine speed helping to seat piston rings. Avoid bogging or lugging the engine down and avoid prolonged running at constant RPM. After the 5 hour break-in period, change the oil.

NOTICE

Synthetic oil may be used after the 5 hour initial break-in period. Using synthetic oil does not decrease the recommended oil change interval. Full synthetic 5W-30 oil will aid in starting in cold ambient < 41° F (5° C) temperatures.

Add Fuel**⚠ DANGER**



Gasoline vapors are highly flammable and extremely explosive.

DO NOT light or smoke cigarettes. Fire or explosion can cause severe burns or death.

Only fill or drain fuel outdoors in a well-ventilated area. DO NOT pump gasoline directly into the lawn edger. Use an approved container to transfer the fuel to the lawn edger.

Never use a gasoline container, gasoline tank, or any other fuel item that is broken, cut, torn or damaged.

DO NOT overfill the gasoline tank. Always keep fuel away from sparks, open flames, pilot lights, heat and other sources of ignition.

Use clean, fresh, regular unleaded gasoline with a minimum octane rating of 87 and an ethanol content of 10% or less by volume.   

DO NOT mix oil with gasoline.

1. Remove the gasoline cap.

2. Slowly add gasoline to the tank. Tank is full when gasoline reaches red circle on screen. DO NOT OVERFILL. Gasoline can expand after filling. A minimum of ¼ in. (6.4 mm) of space left in the tank is required for gasoline expansion, although more than ¼ in. (6.4 mm) is recommended. Gasoline can be forced out of the tank as a result of expansion if overfilled, and can affect the stable running condition of the lawn edger.

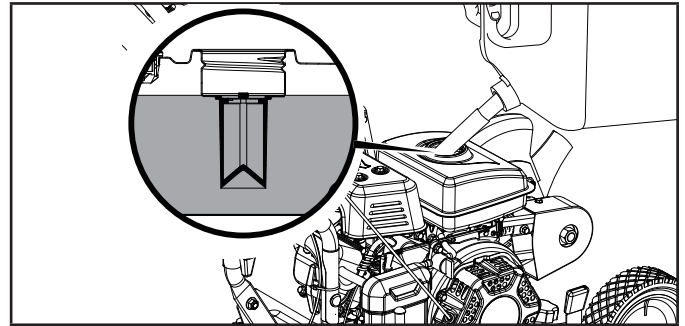

3. Screw on the gasoline cap and wipe away any spilled fuel.

⚠ CAUTION

Use unleaded gasoline with a minimum octane rating of 87 and an ethanol content of 10% or less by volume.

DO NOT light cigarettes or smoke when filling the tank.

DO NOT mix oil and gasoline.

DO NOT overfill the tank. Fill tank to approximately ¼ in. (6.4 mm) below the top of the tank to allow for gasoline expansion.

DO NOT pump gasoline directly into the lawn edger at the pump. Use an approved fuel container to transfer the gasoline to the lawn edger.

DO NOT fill tank indoors.

DO NOT fill tank when the engine is running or hot.

⚠ WARNING

Pouring gasoline too fast through the fuel screen may result in gasoline splashing over the lawn edger and operator while filling.

NOTICE

The lawn edger engine works well with 10% or less ethanol blended gasoline. When using ethanol-gasoline blends there are some issues worth noting:

- Ethanol-gasoline blends can absorb more water than gasoline alone.
- These ethanol blends can eventually separate, leaving water or a watery goo in the tank, fuel valve and carburetor. The compromised gasoline can be drawn into the carburetor and cause damage to the engine and/or create potential hazards.
- If a fuel stabilizer is used, confirm that it is formulated to work with ethanol-gasoline blends.
- Any damages or hazards caused by using ethanol blended gasoline higher than 10% by volume, improperly stored gasoline, and/or improperly formulated stabilizers, are not covered by manufacturer's warranty.

It is advisable to always shut off the gasoline supply and run the engine to starvation after each use. See Storage instructions for extended non-use.

WARNING

Never run the unit without the lawn edger blade guard installed. Use of an improperly assembled unit could result in serious personal injury.

NOTICE

In some State and local jurisdictions, operate power equipment during reasonable hours to comply within local noise ordinances. For more information, contact your State and local government for specific requirements.

Starting the Engine

1. Make certain the lawn edger is on a flat, level surface.
2. Move the depth control lever to the "START" position.

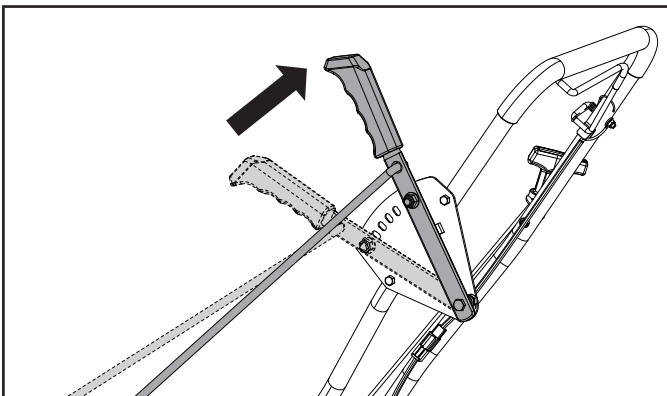

3. Rotate the fuel valve to the "ON" position.

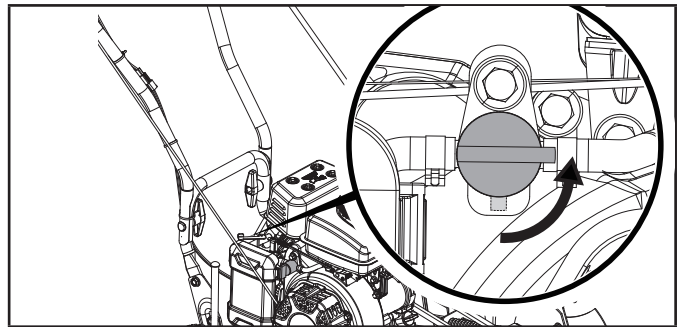

4. Move the choke lever to the "CHOKE" position.

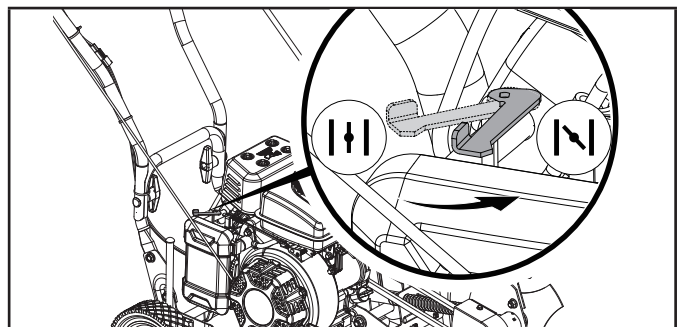

5. Using your left hand, pull the control handle to the upper handle to engage the starting mechanism.

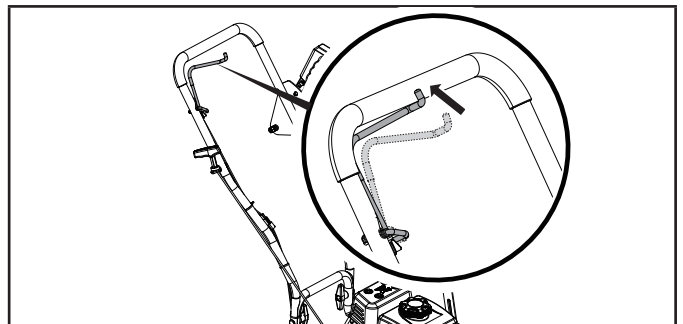

6. Using your right hand, pull the starter cord slowly until resistance is felt and then pull rapidly.

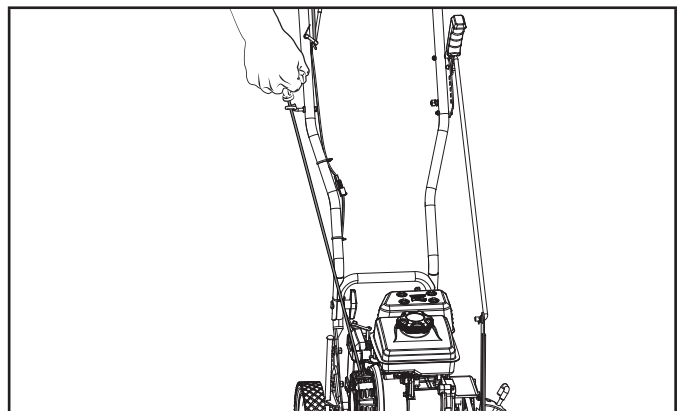

- As the engine warms up, move the choke lever to the "RUN" position.

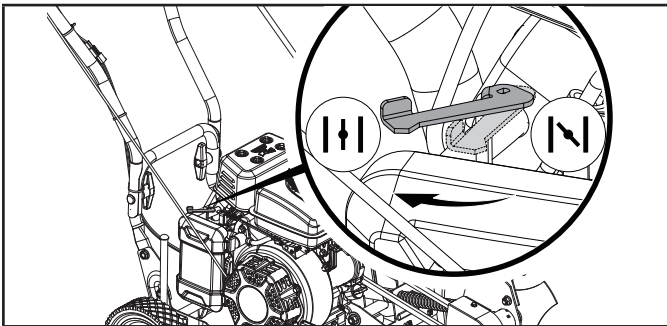

⚠ WARNING

Rapid retraction of the recoil cord could pull your hand and arm towards the engine faster than you can let go. Broken bones, fractures, bruises or sprains could result. Unintentional startup can result in entanglement, traumatic amputation or laceration.

🗨 NOTICE

Allow engine to warm at least 30 seconds depending on ambient temperature. The colder the temperature, the longer the warm-up required.

Stopping the Engine

- Disengage the control lever on the handle.

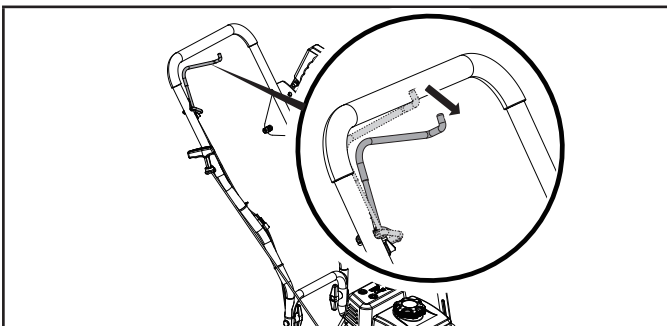

- Rotate the fuel valve to the "OFF" position.

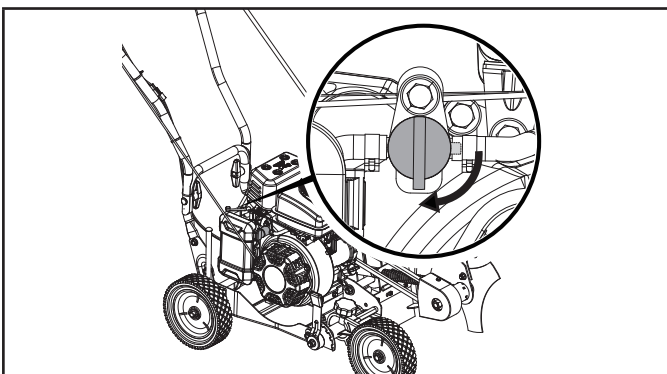

🗨 NOTICE

If the engine will not be used for a period of two (2) weeks or longer, please see the Storage section for proper engine and fuel storage.

Lawn Edger Operation

⚠ WARNING

Always wear eye protection with side shields marked to comply with ANSI Z87.1. Failure to do so could result in objects being thrown into your eyes and other possible serious injuries.

Before Each Use Inspect the Lawn Edger

- Always make sure the spark plug wire has been disconnected and engine has been grounded.
- Always visually inspect the Lawn Edger for loose fittings, cracks, or other damage.
- DO NOT operate the Lawn Edger if there is any indication of damage to parts or the unit.
- Always inspect the engine and make sure the oil level and fuel level are correct before operating.
- Always inspect the work area for any distractions or factors that may prevent operator safety or proper operation.

Adjust the Edging Depth

🗨 NOTICE

There are 5 cutting depth settings from approximately ground level to 2.5 inches (63 mm) deep.

🗨 NOTICE

Do not overload the lawn edger capacity by attempting to edge too deep at too fast a rate. To edge at deeper settings, make multiple passes, first edging at shallow depths.

- Using your left hand, pull the blade depth adjust outward (to the left) to disengage the locking tab then move the lever downward to the desired depth and place the locking tab into the hole at that depth.

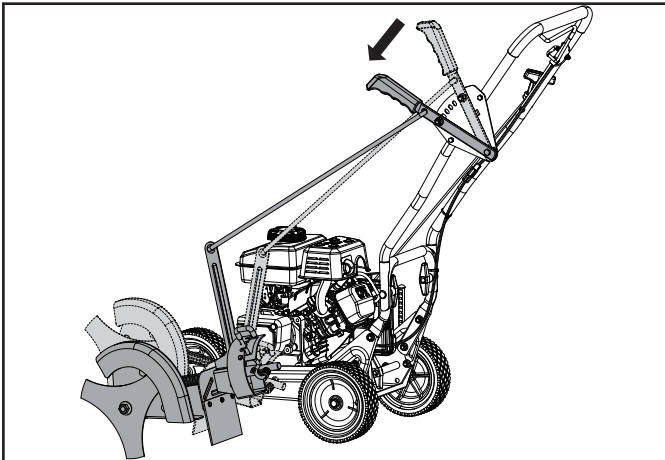

- Once done with the edging task, again pull the blade depth adjust handle outward (to the left) to disengage the locking tab then move the lever upward locking into the top storage position.

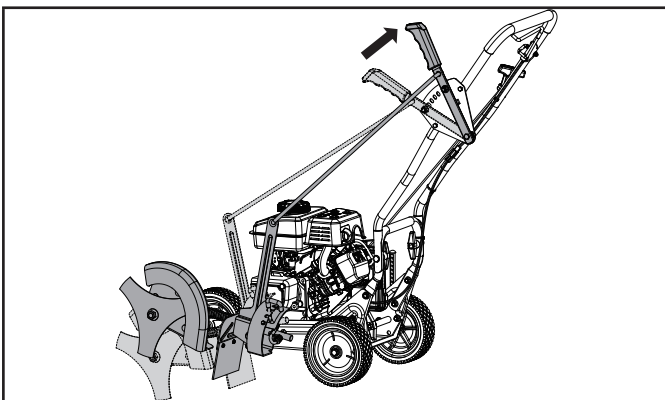

NOTICE

When the lawn edger is not in use, always place the blade adjust lever in the top storage position

Adjust the Blade Bevel Angle

NOTICE

The blade can be adjusted 15 degrees from vertical (both left and right) to provide a beveled edge for decorative edging along mulch/flower beds.

NOTICE

Do not overload the lawn edger capacity by attempting to edge too deep at too fast a rate. To edge at deeper settings, make multiple passes, first edging at shallow depths.

- Stop the engine (see the Stopping the Engine section)
- Disengage the blade bevel lever from the locking slot by pulling toward the rear of the Lawn Edger then move the lever up or down to the desired angle and place the lever back into the locking slot.

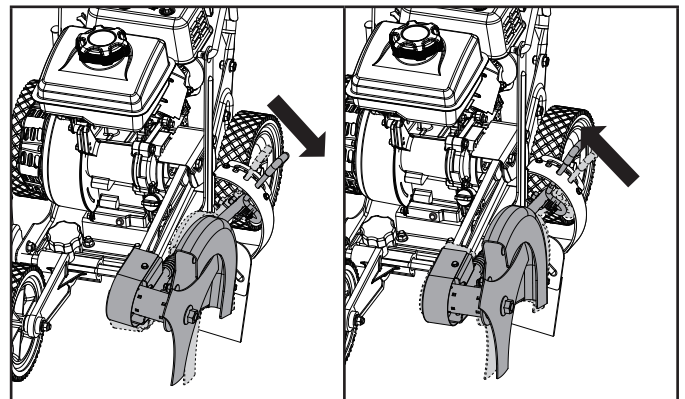

- Start the engine (see the Starting the Engine section), choose your edging depth (see Adjust the Edging Depth section) and start edging.

Operate the Curb Hop Feature

NOTICE

The height of the front wheel and rear wheel are adjustable to allow edging along a curb.

NOTICE

Do not overload the lawn edger capacity by attempting to edge too deep at too fast a rate. To edge at deeper settings, make multiple passes, first edging at shallow depths.

- Stop the engine (see the Stopping the Engine section).

- Loosen the front wheel by turning the knob counterclockwise then slide the wheel outward enough to clear the curb and balance the unit. Once the wheel is adjusted, rotate the knob clockwise and tighten securely.

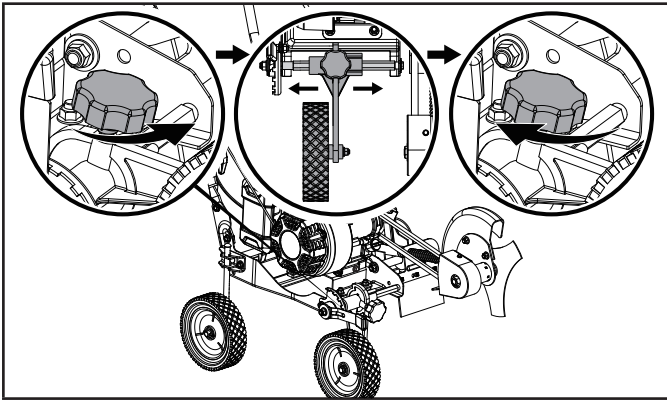

- Adjust the front wheel height by pulling the lever outward to disengage it from the locking tab and moving the lever downward until the desired height is met then place the lever back onto the locking tab at this position.

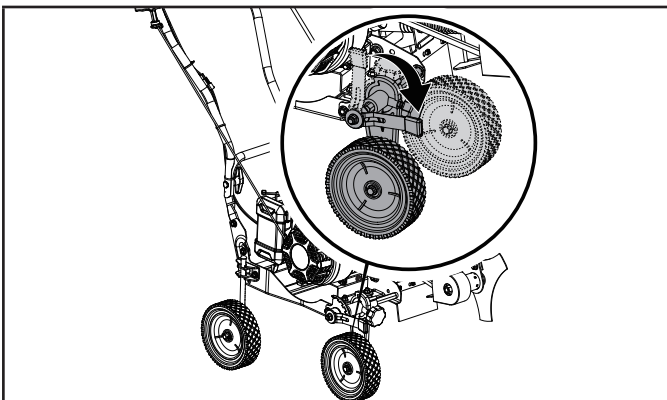

- Loosen the rear wheel locking knob by rotating it counterclockwise then adjust the wheel downward to match the height of the front wheel. Rotate the rear wheel locking handle clockwise and tighten securely.

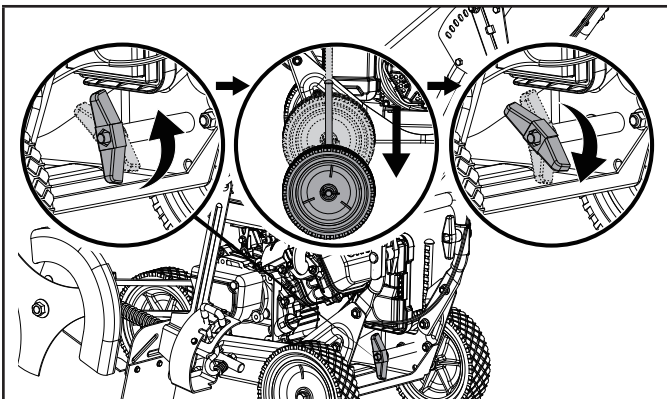

- Start the engine (see the Starting the Engine section), set your edging depth (see the Adjust the Edging Depth section) and start edging along the curb.

MAINTENANCE

Make certain that the lawn edger is kept clean and stored properly. Only operate the unit on a flat, level surface in a clean, dry operating environment. DO NOT expose the unit to extreme conditions, excessive dust, dirt, moisture or corrosive vapors.

The owner/operator is responsible for all periodic maintenance.

Complete all scheduled maintenance in a timely manner.

Correct any issue before operating the lawn edger.

For service or parts assistance, contact our Technical Support Team at 1-877-338-0999.

⚠ WARNING

Never operate a damaged or defective lawn edger.

⚠ WARNING

Improper maintenance will void your warranty.

⚠ WARNING

Before inspecting, cleaning, or servicing the lawn edger, shut off the engine. Wait for all moving parts to stop, disconnect spark plug wire and move it away from the spark plug. Failure to follow these instructions could result in personal injury or damage to the lawn edger.

🗨 NOTICE

For Emission control devices and systems, read and understand your responsibilities for service as stated in the Emission Control Warranty Statement of this manual.

Cleaning the Lawn Edger

⚠ CAUTION

DO NOT spray lawn edger directly with water.

Water can contaminate the fuel system and can enter the engine through the cooling slots and damage the engine.

⚠ WARNING

Do not let brake fluids, gasoline, petroleum-based products, penetrating oils, etc., stay in contact with plastic parts. Chemicals can damage, weaken, or destroy plastic which could result in serious personal injury.

1. Use a damp cloth to clean exterior surfaces of the lawn edger.
2. Use a soft bristle brush to remove dirt and oil.
3. Use an air compressor (25 PSI) to clear dirt and debris from the lawn edger.
4. Inspect all air vents and cooling slots to ensure that they are clean and unobstructed.

Engine Oil Services

Check the engine oil level before each use and after every five hours of continuous operation. Running the engine when it is low on oil will quickly ruin the engine. It is recommended that you change the engine oil after every 10 hours of operation and even sooner when operating in extremely dirty or dusty conditions.

A. Check the Engine Oil Level

1. Park the Lawn Edger on a level area and shut off the engine.
2. Clean around the oil dipstick to prevent dirt from falling into the crankcase.
3. Remove the dipstick and wipe it clean. Reinsert the dipstick completely until it is seated in place and remove it. Add oil as needed to bring the level up to the FULL mark. Wipe the dipstick clean each time the oil level is checked. Do not overfill.

4. Replace the dipstick and ensure it is fully seated in the oil fill port.

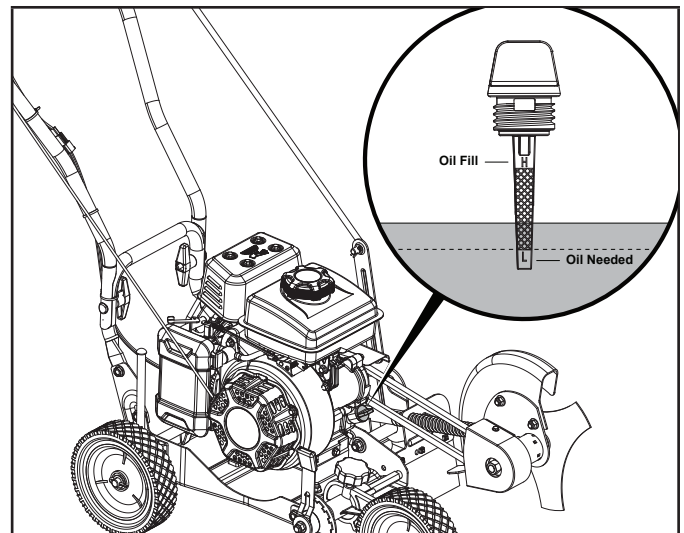

B. Changing the Engine Oil

⚠ CAUTION

DO NOT attempt to crank or start the engine before it has been properly filled with the recommended type and amount of oil. Damage to the Lawn Edger as a result of failure to follow these instructions will void your warranty.

Change oil when the engine is warm. Refer to the oil specification to select the proper grade for your operating environment.

1. Place the Lawn Edger on a flat, level surface.
2. Remove the spark plug cable from the spark plug.

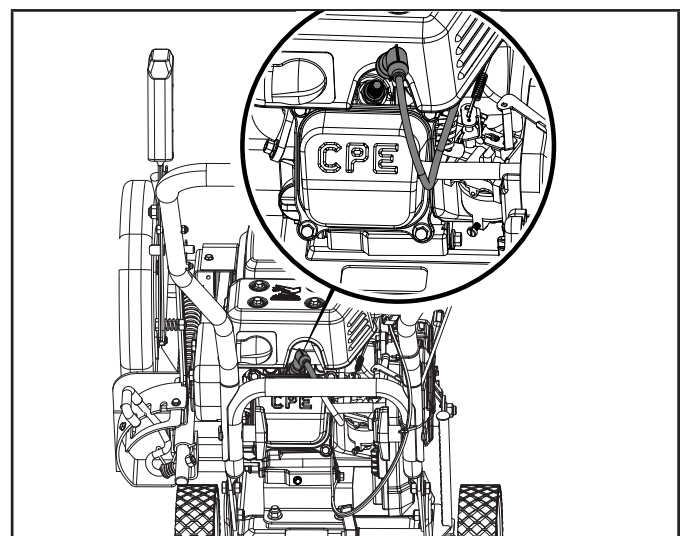

3. Clean around the oil drain plug to prevent dirt falling into the crankcase. Remove the oil drain plug with a 10mm socket (not included).

4. Allow the oil to drain completely into an appropriate container.

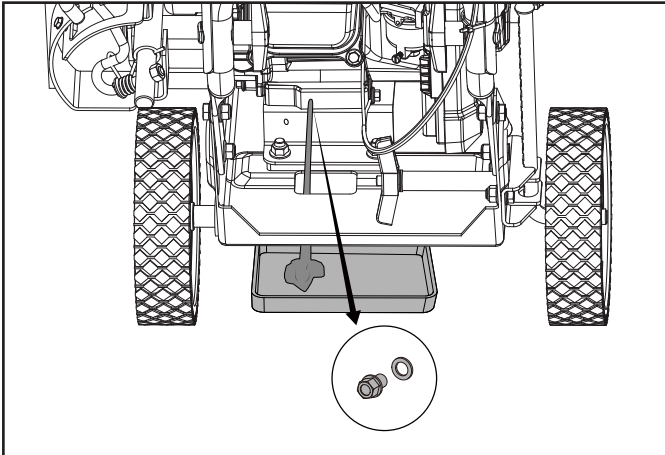

5. Replace the oil drain plug
6. Add fresh oil (see Add Engine Oil section)
7. DO NOT OVERFILL. Oil not included for routine maintenance
8. Dispose of used oil at an approved waste management facility.

NOTICE

Once oil has been added, a visual check should show oil about 1-2 threads from running out of the fill hole. When using the dipstick to check oil level, DO NOT screw in the dipstick while checking.

Cleaning and Adjusting the Spark Plug(s)

1. Remove the spark plug cable from the spark plug.

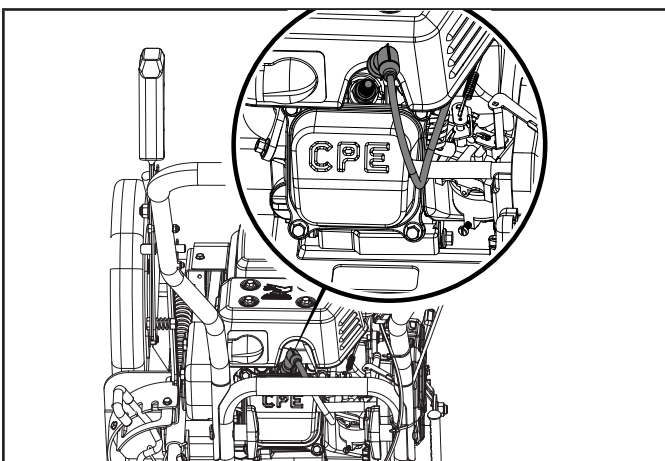

2. Use a spark plug socket tool (included), or a 5/8 in. (16 mm) socket (not included) to remove the plug.
3. Inspect the electrode on the plug. It must be clean and not worn to produce the spark required for ignition.
4. Make certain the spark plug gap is 0.023-0.031 in. (0.6-0.8 mm).

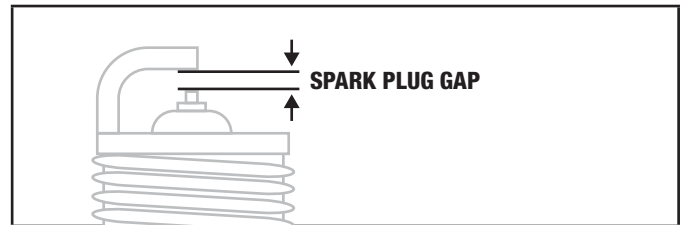

Cleaning the Air Filter

1. Remove the plastic air cleaner cover by pressing the tab on the side of the cover at the rear of the unit then rotating the filter outward to release the locking tabs on the other side of the filter cover.
2. Remove the foam element.
3. Wash the element in liquid detergent and water. Squeeze thoroughly dry in a clean cloth.
4. Saturate in clean engine oil
5. Squeeze in a clean, absorbent cloth to remove all excess oil.
6. Place the filter element in the assembly.
7. Reattach the plastic filter cover by inserting the locking tabs on the side closest to the recoil rope housing then pivot the other side into place. Ensure that the filter cover snaps into place.

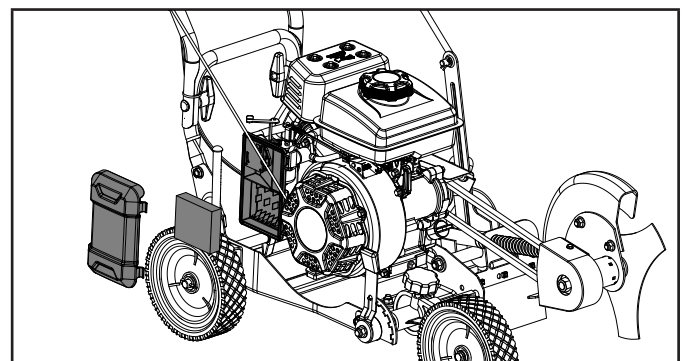

Changing the Blade

⚠ WARNING

DO NOT sharpen the blade. Sharpening can damage the blade, unbalance the blade and cause it to break, which can cause injury to you, bystanders or cause property damage.

1. Stop the engine (see Stopping the Engine section)
2. Disconnect the spark plug wire from the spark plug
3. You will need two adjustable wrenches or two $\frac{3}{4}$ in. (19 mm) wrenches.
4. Place one wrench on the bolt on the back side of the blade guard and hold it tightly in place
5. Place the other wrench on the blade lock nut on the outside of the blade and turn counterclockwise while holding the bolt on the back side securely in place.
6. Remove the used blade and replace with the new blade and tighten securely into place by doing the above steps in reverse.

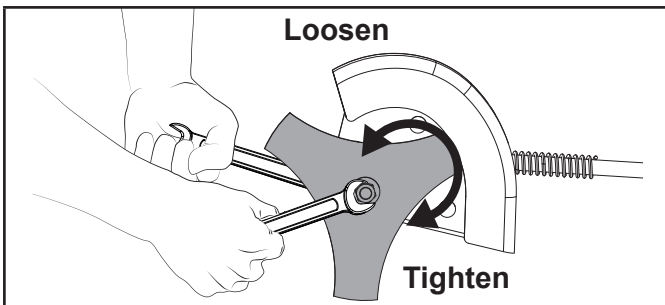

Replace the Belt

1. Stop the engine (see Stopping the Engine section)
2. Disconnect the spark plug wire from the spark plug
3. To ease the replacement of the belt, disconnect the control rod from the blade adjust arm. This will provide slack in the belt.
4. Using a 6 mm hex wrench and a 13 mm wrench or socket, remove the two bolts from the rear pulley guard and remove the guard.

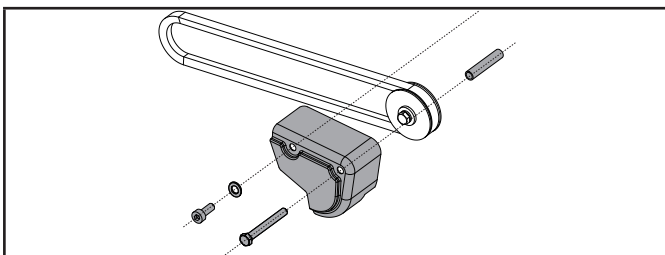

5. Using a 8 mm wrench or socket remove the two screws from the front pulley guard and remove the guard.

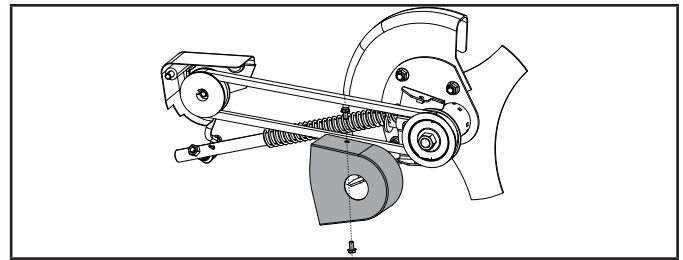

6. Remove the old belt from the pulleys
7. Install the new belt on the pulleys.
8. Reassemble the belt guards.
9. Reattach the control rod to the blade adjust arm.

Adjusting the Governor

⚠ WARNING

Tampering with the factory set governor will void your warranty.

The air-fuel mixture is not adjustable. Tampering with the factory set governor can damage your lawn edger. Contact our Technical Support Team at 1-877-338-0999 for all other service and/or adjustment needs.

Maintenance Schedule

Follow the service intervals indicated in the following maintenance schedule.

Service your lawn edger more frequently when operating in adverse conditions.

Contact our Technical Support Team at 1-877-338-0999 to locate the nearest CPE certified service dealer for your lawn edger or engine maintenance needs.

EVERY 8 HOURS OR PRIOR TO EACH USE

- Check oil level
- Clean around air intake and muffler

FIRST 5 HOURS (BREAK IN)

- Change oil

EVERY 50 HOURS OR EVERY SEASON

- Clean air filter.
- Change oil if operating under heavy load or in hot environments.

EVERY 100 HOURS OR EVERY SEASON

- Change oil
- Clean/adjust spark plug
- Check/adjust valve clearance*
- Clean fuel tank and filter*

EVERY 250 HOURS

- Clean combustion chamber*

EVERY 3 YEARS

- Replace fuel line*

*To be performed by knowledgeable, experienced owners or CPE certified service centers.

STORAGE

Refer to the Maintenance section for proper cleaning instructions.

1. Allow the Lawn Edger to cool completely before storage.
2. Clean the Lawn Edger according to the instructions in the Maintenance section.
3. Store the unit in a clean, dry area out of direct sunlight.

Short Term Engine Storage (Up to 30 Days)

1. Allow the engine to cool completely before storage.
2. Clean engine according to the Maintenance section.
3. To extend the fuel storage life add a properly formulated fuel stabilizer to the tank.

Long Term Engine Storage (30 Days – 1 Year)

1. Add a properly formulated fuel stabilizer to the tank.
2. Run the engine for a few minutes so the treated fuel cycles through the fuel system and carburetor.
3. The engine needs to cool completely before cleaning and storage.
4. Clean the engine according to the Maintenance section.
5. Change the oil according to the Maintenance section.
6. Remove the spark plug and pour about 1/2 oz. (14.9 mL) of oil into the cylinder. Crank the engine slowly to distribute the oil and lubricate the cylinder.
7. Reattach the spark plug.

⚠ WARNING

Never store the lawn edger indoors or next to appliances where there is a source of heat, open flame, spark or pilot light as these conditions can ignite gasoline vapors. DO NOT store the lawn edger near fertilizer or any corrosive material. Even with an empty fuel tank, gasoline vapors could ignite. When storing the lawn edger for short or long periods of time, always be sure that the engine switch (where applicable) and the fuel valve (where applicable) are set in the "OFF" position.

🗨 NOTICE

The lawn edger engine works well with 10% or less ethanol blended gasoline. When using ethanol-gasoline blends there are some issues worth noting:

- Ethanol-gasoline blends can absorb more water than gasoline alone.
- These ethanol blends can eventually separate, leaving water or a watery goo in the tank, fuel valve and carburetor. The compromised gasoline can be drawn into the carburetor and cause damage to the engine and/or create potential hazards.
- If a fuel stabilizer is used, confirm that it is formulated to work with ethanol-gasoline blends.
- Any damages or hazards caused by using ethanol blended gasoline higher than 10% by volume, improperly stored gasoline, and/or improperly formulated stabilizers, are not covered by manufacturer's warranty.

It is advisable to always shut off the gasoline supply (where applicable - not every unit has a fuel shut off) and run the engine to starvation after each use. See Storage instructions for extended non-use.

🗨 NOTICE

To avoid possible damage to the threads, do not try to remove the plug from a hot aluminum cylinder head.

SPECIFICATIONS

Lawn Edger Specifications

Model	201465
Edging Depth	0 – 2.5 in. (0 – 63 mm)
Blade Diameter	9 in. (228 mm), 3 Point
Blade Center Hole Diameter	0.5 in. (12.9 mm)
Wheel Diameter	7 in. (177.8 mm)

Overall Dimensions

Weight	55 lbs. (25kg)
Length	42.1 in. (107 cm)
Width	18.9 in. (48 cm)
Height	40.4 in. (102.5 cm)

Engine Specifications

Model	R80-VP
Displacement	79cc
Type	4-Stroke OHV

Spark Plug

OEM Type	A5RTC
Replacement Type	NGK CR5HSA or equivalent
Gap	0.023 - 0.031 in. (0.6 - 0.8 mm)

Valve

Intake Clearance	0.00197 - 0.0059 in. (0.05 - 0.15 mm)
Exhaust Clearance	0.00197 - 0.0059 in. (0.05 - 0.15 mm)

NOTICE

A technical bulletin regarding valve adjustment procedures is available at www.championpowerequipment.com.

Oil Specifications

NOTICE

Temperature will affect engine oil and engine performance. Change the type of engine oil used based on temperature shown in the “Recommended Engine Oil Type” table.

DO NOT OVERFILL.

Type	*See following chart
Capacity	11.8 fl. oz. (350 ml)

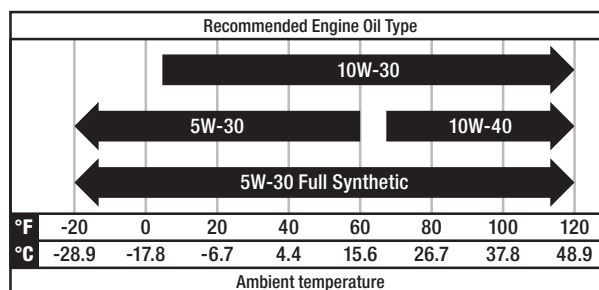

Fuel Specifications

Use unleaded gasoline with a minimum octane rating of 87 and an ethanol content of 10% or less by volume. DO NOT USE E15 or E85. DO NOT OVERFILL.

Gasoline Capacity	0.37 gal. (1.4 L)
-------------------------	-------------------

Temperature Specifications

Starting Temperature Range (°F/°C)	5 to 104/-15 to 40
--	--------------------

NOTICE

An important message about temperature: Your product is designed and rated for continuous operation at ambient temperatures up to 104°F (40°C). When needed, it may be operated at temperatures ranging from 5°F (-15°C) to 122°F (50°C) for short periods of time. If exposed to temperatures outside this range during storage, it should be brought back within this range before operation. In any event, the product must always be operated outdoors, in a well-ventilated area and away from doors, windows and vents.

TROUBLESHOOTING

Problem	Cause	Solution
Engine Difficult to Start	Spark plug is disconnected.	Reconnect wire.
	Fuel tank is empty.	Add fuel.
	Fuel valve is off.	Turn the fuel valve on.
	Choke control is in incorrect position.	Move to CHOKE position.
	Stale gasoline.	Drain fuel and add fresh fuel.
	Dirty air filter.	Clean or replace air filter.
	Defective or incorrectly gapped spark plug.	Inspect spark plug.
	Carburetor out of adjustment.	Contact Technical Support Team.
	Dirt or water in fuel tank.	Contact Technical Support Team.
Engine Runs Poorly	Defective or incorrectly gapped spark plug.	Inspect the spark plug.
	Dirty air filter.	Clean or replace air filter.
	Carburetor out of adjustment.	Contact Technical Support Team.
	Stale gasoline.	Drain fuel and add fresh fuel.
	Dirt or water in fuel tank.	Contact Technical Support Team.
Engine Overheats	Engine cooling system clogged.	Clean air-cooling system.
	Carburetor out of adjustment.	Contact Technical Support Team.
	Oil level is low.	Check oil level.
Excessive vibration/noise	Loose parts.	Check and tighten all fasteners.
	See engine problems above.	See engine solutions above.
Engine does not shut off	Mis-adjusted ignition switch.	Contact Technical Support Team.
Blade will not rotate	Debris interfering with the blade.	Remove debris from the blade.
	Blade loose.	Tighten blade nuts.
	Belt loose.	Replace belt.
Blade will not edge properly	Damaged or worn blade.	Replace blade.
Frequent engine stalling	Excessive edging speed/blade.	Edge at a more moderate pace or make multiple passes.
	See engine problems above.	See engine solutions above.

For other issues and technical support:

Technical Support Team
Toll Free 1-877-338-0999
support@championpowerequipment.com

WARRANTY*

CHAMPION POWER EQUIPMENT
2 YEAR LIMITED WARRANTY

Warranty Qualifications

To register your product for warranty and FREE lifetime call center technical support please visit:

<https://www.championpowerequipment.com/register>

To complete registration you will need to include a copy of the purchase receipt as proof of original purchase. Proof of purchase is required for warranty service. Please register within ten (10) days from date of purchase.

Repair/Replacement Warranty

CPE warrants to the original purchaser that the mechanical and electrical components will be free of defects in material and workmanship for a period of two years (parts and labor) from the original date of purchase and 180 days (parts and labor) for commercial and industrial use. Transportation charges on product submitted for repair or replacement under this warranty are the sole responsibility of the purchaser. This warranty only applies to the original purchaser and is not transferable.

Do Not Return The Unit To The Place Of Purchase

Contact CPE's Technical Service and CPE will troubleshoot any issue via phone or e-mail. If the problem is not corrected by this method, CPE will, at its option, authorize evaluation, repair or replacement of the defective part or component at a CPE Service Center. CPE will provide you with a case number for warranty service. Please keep it for future reference. Repairs or replacements without prior authorization, or at an unauthorized repair facility, will not be covered by this warranty.

Warranty Exclusions

This warranty does not cover the following:

Normal Wear

Products with mechanical and electrical components need periodic parts and service to perform well. This warranty does not cover repair when normal use has exhausted the life of a part or the equipment as a whole.

Installation, Use and Maintenance

This warranty will not apply to parts and/or labor if the product is deemed to have been misused, neglected, involved in an accident, abused, loaded beyond the product's limits or modified. Normal maintenance is not covered by this warranty and is not required to be performed at a facility or by a person authorized by CPE.

Other Exclusions

This warranty excludes:

- Cosmetic defects such as paint, decals, etc.
- Wear items such as starter pulleys, starter ropes, filter elements, belts and blades.
- Failures due to acts of God and other force majeure events beyond the manufacturer's control.
- Problems caused by parts that are not original Champion Power Equipment parts.

Limits of Implied Warranty and Consequential Damage

Champion Power Equipment disclaims any obligation to cover any loss of time, use of this product, freight, or any incidental or consequential claim by anyone from using this product. THIS WARRANTY AND THE ATTACHED U.S. EPA and/or CARB EMISSION CONTROL SYSTEM WARRANTIES (WHEN APPLICABLE) ARE IN LIEU OF ALL OTHER WARRANTIES, EXPRESS OR IMPLIED, INCLUDING WARRANTIES OF MERCHANTABILITY OR FITNESS FOR A PARTICULAR PURPOSE.

A unit provided as an exchange will be subject to the warranty of the original unit. The length of the warranty governing the exchanged unit will remain calculated by reference to the purchase date of the original unit.

This warranty gives you certain legal rights which may change from state to state or province to province. Your state or province may also have other rights you may be entitled to that are not listed within this warranty.

Contact Information

Address

Champion Power Equipment, Inc.
6370 S Pioneer Way, Unit 101
Las Vegas, NV 89113 USA
www.championpowerequipment.com

Customer Service

Toll Free: 1-877-338-0999
info@championpowerequipment.com
Fax no.: 1-562-236-9429

Technical Service

Toll Free: 1-877-338-0999
tech@championpowerequipment.com

📞 EMERGENCY 24 HOUR SUPPORT: 1-562-204-1188

**CHAMPION POWER EQUIPMENT, INC. (CPE)
AND THE UNITED STATES ENVIRONMENTAL PROTECTION AGENCY (U.S. EPA)
EMISSION CONTROL SYSTEM WARRANTY**

Your Champion Power Equipment (CPE) engine complies with U.S. EPA emissions regulations.

YOUR WARRANTY RIGHTS AND OBLIGATIONS:

The US EPA and CPE are pleased to explain the Federal Emission Control Systems Warranty on your 2025 small off-road engine and engine powered equipment. New engines and equipment must be designed, built and equipped, at the time of sale, to meet U.S. EPA regulations for small off-road engines. CPE warrants the emission control system on your small off-road engine and equipment for the period of time listed below, provided there has been no abuse, neglect, unapproved modification, or improper maintenance of your equipment.

Your emission control system may include parts such as the carburetor, fuel-injection system, the ignition system, catalytic converter and fuel lines. Also included may be hoses, belts, connectors and other emission related assemblies. Where a warrantable condition exists, CPE will repair your small off-road engine at no cost to you including diagnosis, parts and labor.

MANUFACTURER'S EMISSION CONTROL SYSTEM WARRANTY COVERAGE:

This emission control system is warranted for two years, subject to provisions set forth below. If, during the warranty period, an emission related part on your engine is defective in materials or workmanship, the part will be repaired or replaced by CPE.

OWNER'S WARRANTY RESPONSIBILITIES:

As the small off-road engine owner, you are responsible for the performance of the required maintenance listed in your Owner's Manual. CPE recommends that you retain all your receipts covering maintenance on your small off-road engine, but CPE cannot deny warranty solely for the lack of receipts or for your failure to ensure the performance of all scheduled maintenance.

As the small off-road engine owner, you should however be aware that CPE may deny you warranty coverage if your small, off-road engine or a part has failed due to abuse, neglect, improper maintenance or unapproved modifications.

You are responsible for presenting your small off-road engine to an Authorized CPE service outlet or alternate service outlet as described in (3)(f.) below, CPE dealer or CPE, Las Vegas, NV. as soon as a problem exists. The warranty repairs should be completed in a reasonable amount of time, not to exceed 30 days.

If you have any questions regarding your warranty rights and responsibilities, you should contact:

Champion Power Equipment, Inc.
Customer Service
6370 S Pioneer Way, Unit 101
Las Vegas, NV 89113
1-877-338-0999
tech@championpowerequipment.com

EMISSION CONTROL SYSTEM WARRANTY

The following are specific provisions relative to your Emission Control System (ECS) Warranty Coverage.

- 1. APPLICABILITY:** This warranty shall apply to 1997 and later model year small off-road engines. The ECS Warranty Period shall begin on the date the new engine or equipment is delivered to its original, end-use purchaser, and shall continue for 24 consecutive months thereafter.
- 2. GENERAL EMISSIONS WARRANTY COVERAGE**

CPE warrants to the original, end-use purchaser of the new engine or equipment and to each subsequent purchaser that the ECS when installed is:

 - 2a. Designed, built and equipped so as to conform to U.S. EPA emissions standards for spark-ignited engines at or below 19 kilowatts.
 - 2b. Free from defects in materials and workmanship that cause the failure of a warranted part to be identical in all material respects to the part as described in the engine manufacturer's application for certification for a period of two years.
- 3. THE WARRANTY ON EMISSION-RELATED PARTS WILL BE INTERPRETED AS FOLLOWS:**
 - 3a. Any warranted part that is not scheduled for replacement as required maintenance in the Operator's Manual shall be warranted for the ECS Warranty Period. If any such part fails during the ECS Warranty Period, it shall be repaired or replaced by CPE according to Subsection "d" below. Any such part repaired or replaced under the ECS Warranty shall be warranted for any remainder of the ECS Warranty Period.
 - 3b. Any warranted, emissions-related part which is scheduled only for regular inspection as specified in the Operator's Manual shall be warranted for the ECS Warranty Period. A statement in such written instructions to the effect of "repair or replace as necessary", shall not reduce the ECS Warranty Period. Any such part repaired or replaced under the ECS Warranty shall be warranted for the remainder of the ECS Warranty Period.
 - 3c. Any warranted, emissions-related part which is scheduled for replacement as required maintenance in the Operator's Manual shall be warranted for the period of time prior to the first scheduled replacement point for that part. If the part fails prior to the first scheduled replacement, the part shall be repaired or replaced by CPE according to Subsection "d" below. Any such emissions-related part repaired or replaced under the ECS Warranty, shall be warranted for the remainder of the ECS Warranty Period prior to the first scheduled replacement point for such emissions-related part.
 - 3d. Repair or replacement of any warranted, emissions-related part under this ECS Warranty shall be performed at no charge to the owner at a CPE Authorized Service Outlet.
 - 3e. The owner shall not be charged for diagnostic labor which leads to the determination that a part covered by the ECS Warranty is in fact defective, provided that such diagnostic work is performed at a CPE Authorized Service Outlet.
 - 3f. CPE shall pay for covered emissions warranty repairs at non-authorized service outlets under the following circumstances:
 - i. The service is required in a population center with a population over 100,000 according to U.S. Census 2000 without a CPE Authorized Service Outlet AND
 - ii. The service is required more than 100 miles from a CPE Authorized Service Outlet. The 100 mile limitation does not apply in the following states: Alaska, Arizona, Colorado, Hawaii, Idaho, Montana, Nebraska, Nevada, New Mexico, Oregon, Texas, Utah and Wyoming.
 - 3g. CPE shall be liable for damages to other original engine components or approved modifications proximately caused by a failure under warranty of an emission-related part covered by the ECS Warranty.
 - 3h. Throughout the ECS Warranty Period, CPE shall maintain a supply of warranted emission-related parts sufficient to meet the expected demand for such emission-related parts.
 - 3i. Any CPE Authorized and approved emission-related replacement part may be used in the performance of any ECS Warranty maintenance or repair and will be provided without charge to the owner. Such use shall not reduce CPE's warranty obligation.
 - 3j. Unapproved add-on or modified parts may not be used to modify or repair a CPE engine. Such use voids this ECS Warranty and shall be sufficient grounds for disallowing an ECS Warranty claim. CPE shall not be liable hereunder for failures of any warranted parts of a CPE engine caused by the use of such an unapproved add-on or modified part.

EMISSION-RELATED PARTS INCLUDE THE FOLLOWING: (using those portions of the list applicable to the engine)

Systems covered by this warranty	Parts Description
Fuel Metering System	Fuel regulator, Carburetor and internal parts
Air Induction System	Air cleaner, Intake manifold
Ignition System	Spark plug and parts, Magneto ignition system
Exhaust System	Exhaust manifold, catalytic converter
Miscellaneous Parts	Tubing, Fittings, Seals, Gaskets, and Clamps associated with these listed systems.
Evaporative Emissions	Fuel Tank, Fuel Cap, Fuel Lines (for liquid fuel and fuel vapors), Fuel Line Fittings, Clamps, Pressure Relief Valves, Control Valves, Control Solenoids, Electronic Controls, Vacuum Control Diaphragms, Control Cables, Control Linkages, Purge Valves, Gaskets, Liquid/Vapor Separator, Carbon Canister, Canister Mounting Brackets, Carburetor Purge Port Connector

TO OBTAIN WARRANTY SERVICE:

You must take your CPE engine or the product on which it is installed, along with your warranty registration card or other proof of original purchase date, at your expense, to any Champion Power Equipment dealer who is authorized by Champion Power Equipment, Inc. to sell and service that CPE product during his normal business hours. Alternate service locations defined in Section (3)(f.) above must be approved by CPE prior to service. Claims for repair or adjustment found to be caused solely by defects in material or workmanship will not be denied because the engine was not properly maintained and used.

If you have any questions regarding your warranty rights and responsibilities, or to obtain warranty service, please write or call Customer Service at Champion Power Equipment, Inc.

Champion Power Equipment, Inc.
6370 S Pioneer Way, Unit 101
Las Vegas, NV 89113
1-877-338-0999
Attn.: Customer Service
tech@championpowerequipment.com