

# Deep Seating Loveseat & Sofa

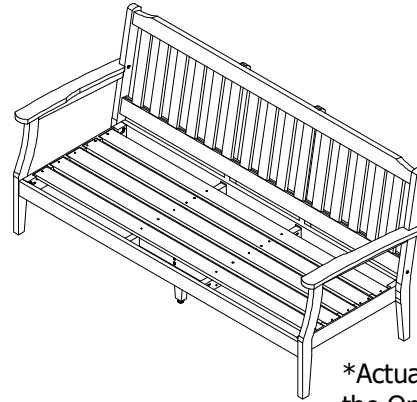

## Assembly Guide

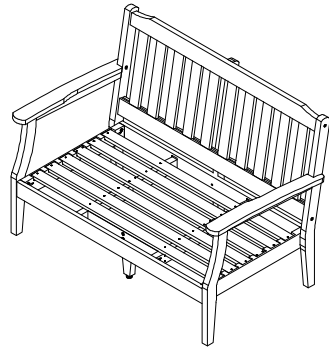

DSL02  
DSL03

\*Actual Style May Vary from  
the One Pictured in this Guide

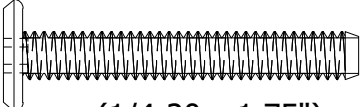
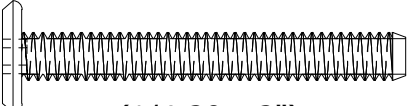
### HARDWARE INCLUDED

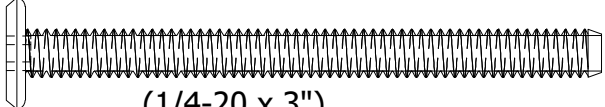
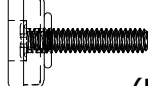
- A**  Qty: 2  
(1/4-20 x 1.75")
- B**  Qty: 11  
(1/4-20 x 2")
- C**  Qty: 4  
(1/4-20 x 2.5")
- D**  Qty: 4  
(1/4-20 x 3")
- E**  Qty: 3  
(Leveling Foot)

### TOOLS INCLUDED

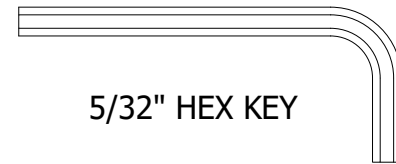

5/32" HEX KEY

### CUSTOMER SUPPLIED TOOLS

Cordless screwdriver/drill OR  
multi-bit handle for the T-15 bit

### IMPORTANT!

DO NOT fully tighten bolts until all bolts are started.

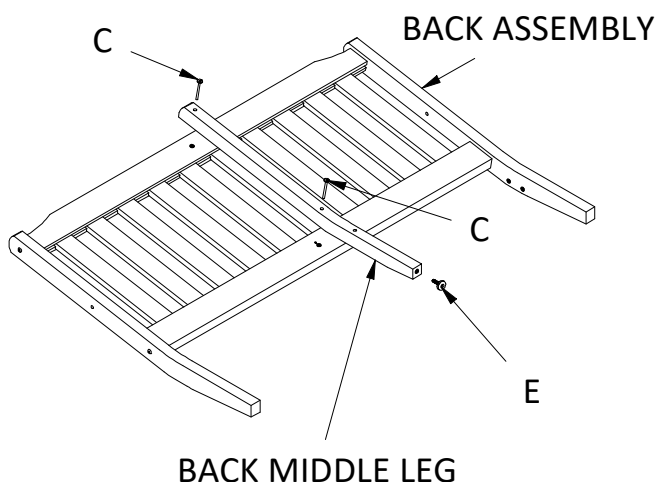

### STEP 1

Lay the Back Assembly on the ground and attach the Back Middle Leg with (2) C Bolts. **(If you are building the Sofa you will have (2) Back Middle Legs and (4) C bolts.)**

### STEP 2

Attach (1) E Leveling foot to the Back Middle Leg. (Adjust height as needed) **(If you are building the Sofa you will have (2) E Leveling Feet)**

### LEFT ARM ASSEMBLY

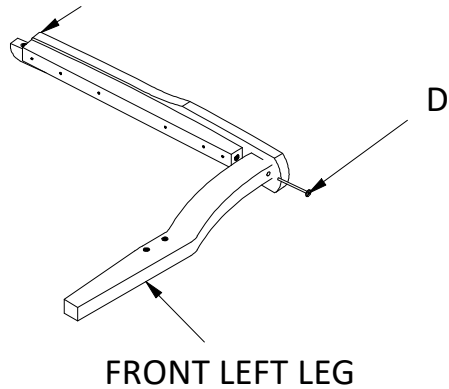

### STEP 3

Attach the Front Left Leg to the Left Leg Assembly using (1) D bolt.

### STEP 4

Repeat Step 3 for attaching the Front Right Leg & Right Arm Assembly.

### SEAT ASSEMBLY

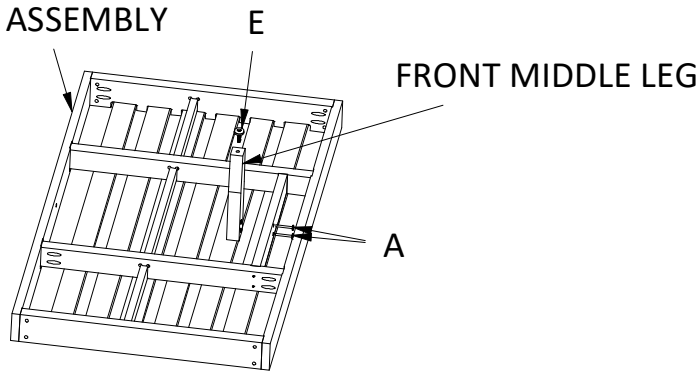

### STEP 5

Attach the Front Middle Leg to the Seat Assembly using (2) A Bolts.

### STEP 6

Attach (1) E Leveling foot to the Front Middle Leg. (Adjust height as needed)

### Back Assembly

### Seat Assembly

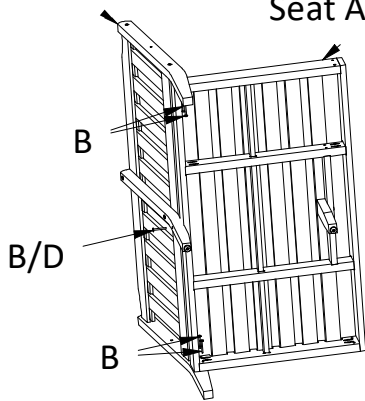

### STEP 7

Attach the Back Assembly to the Seat Assembly using (5) B Bolts As Shown.

### STEP 8

If you are Building a Sofa you will you (4) B Bolts & (2) D Bolts.

### Left Arm Assembly

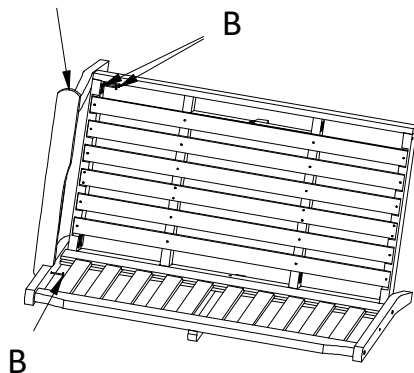

### STEP 9

Attach the Left Arm Assembly Using (3) B Bolts as shown.

### STEP 10

Repeat Step 9 on the other side.