

## Smart Toilet (DV-1S0159-V1)

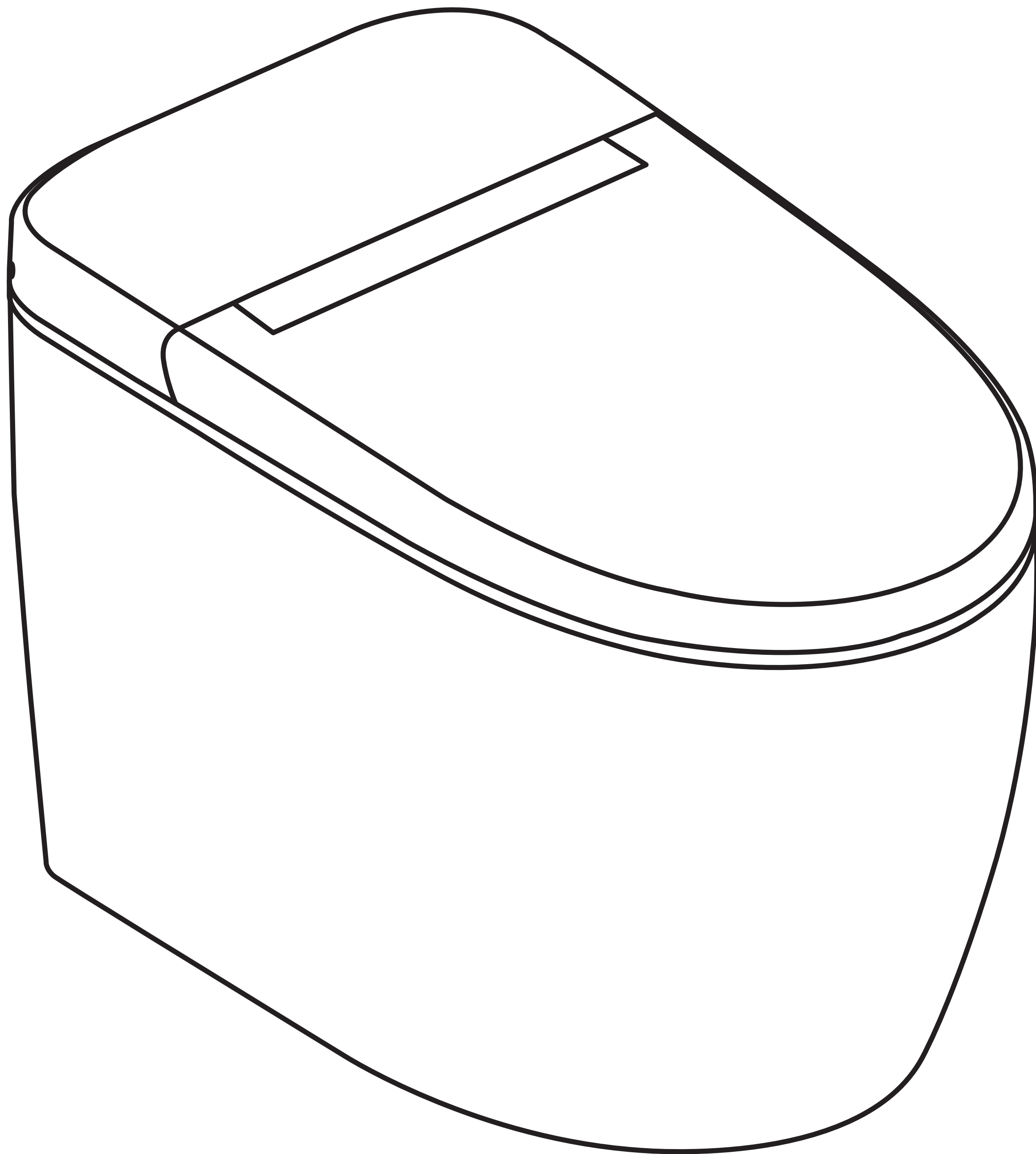

NOTE: Drawings may not exactly define contour of the product.



## Prior to Installation:

- Inspect toilet to ensure no damages have occurred while in shipping.
- Observe all plumbing and building codes in accordance with your state and local requirements.
- Remove old toilet.
- Make sure mounting surface is CLEAN and LEVEL.

### General Recommendations:

Please read installation and maintenance instructions thoroughly before installing the toilet.

Be sure to use proper tools and always wear proper personal safety accessories for your protection.

**If you have any questions or concerns  
please contact us:**

(+1) 312-626-9466  
service@deervalleybath.com

# TABLE OF CONTENTS

● Safety Precautions .....	02
● Component List .....	05
● Specification .....	06
● Function Table .....	07
● Parts Names .....	08
● Product Drawing .....	09
● Power and Water Connection .....	09
● Installation Precaution .....	10
● Product Installation .....	11
● Side Control Using Instructions .....	16
● Other Functions Instruction .....	16
● Cleaning & Maintenance .....	17
● How to do .....	18
● Troubleshooting .....	19
● Maintenance Service Sheet .....	20



## Safety Precautions

To prevent damage to the unit and possible injury to users, please follow the safety warnings. Please be sure to carefully read through the user's manual before installation. Keep the user's manual after installation to refer to for troubleshooting advice.



## Symbols and Meanings

 <b>WARNING</b>	Could result in serious injury or death.
---	--



The following symbols are used to indicate important safety precautions when using the product.

	Prohibited.
	Pay close attention; caution.

NOTE: Specialized tools may be necessary to install DeerValley Smart Toilet, plumbing not included.

 Prohibited	 <b>WARNING</b>
	<p>It is not allowed to continue using if the product has some breakdown:          Product heat abnormally;          Product is smoking;          Product has abnormal sound and smell;          Product is leaking, broken or damaged;          Toilet pan is blocked, etc.          When the breakdown happens, if it do not handle in time and continue using, it might trigger the problems like electric shock, injury, firing or water penetration inside the room, etc.</p>
	<p>Banana oil, gasoline, putty-powder, nylon brush or other (non-neutral) detergent is not allowed to clean the plastic parts like toilet seat cover, otherwise it might trigger chemical reaction or leakage, damage the product and cause people injury.</p>
	<p>Loosen electric outlet is not allowed as it might trigger electric shock or firing.</p>
	<p>It is not allowed to pull out and plug in the electric plug by wet hand as it might trigger electric shock or firing.</p>
	<p>It is not allowed to touch the electric plug when it is thundering and lighting as it might trigger electric shock.</p>
	<p>It is not allowed to use other electric resource, the load of using electric outlet could not be too big, as it might trigger firing due to over-heat.</p>
	<p>Detergent, water, wash detergent or urine is not allowed to spot into body and electric outlet, as it might trigger electric shock or firing.</p>
	<p>It is not allowed to let child standing or put heavy goods on the seat and cover, toilet pan or seat body, heavy hitting or knocking is not allowed.</p>
	<p>It is not allowed to disassemble, repair this product, (it must go for professional repair person service if it is necessary to repair), otherwise, it might cause the damage to this product.</p>
	<p>Do not randomly damage the electric plug and electric line, if the electric line, electric plug is damaged, please do not use it any longer or repair by oneself, it must be repaired by professional person, otherwise, it might trigger short-circuit, electric shock, firing.</p>
	<p>If the power cord is not long enough, please do not use a extension cord.</p>
	<p>The stove or lighted cigarette is not allowed to be placed next to the toilet pan, cigarette butt etc is not allowed to be thrown into toilet pan.</p>
	<p>Do not block the aiopenings of the product. Keep the air openings free of lint, hair, and the like.</p>
<p>Do not use while bathing.</p>	

NOTE: Drawings may not exactly define contour of the product.

 <p>Caution</p>	 <b>WARNING</b>
	<p>When using in shower room, please install air exchange equipment to ensure the air in the shower room not too moist. This product is electric products, it is not allowed to install it in the place that is easy high wet, easy split by water, otherwise it might trigger electric shock or fire.</p>
	<p>Please ensure to cut off the electric power before washing this product, do not use water to directly wash this product, otherwise it might trigger the electric shock or fire.</p>
	<p>Please put and use this product in the shadow, must not put directly beneath the sun, otherwise it might cause the color-fading, or burn the surface of product due to the instability of temperature.</p>
	<p>Do not use industrial water, wastewater, seawater, reclaimed water and other sewage, otherwise it may cause skin inflammation and other problems.</p>
	<p>Persons (including children) with physical, perceptual, intellectual disabilities or lack of experience and common sense need to use the product under the guidance or supervision of someone else, or they may cause electric shock, injury or fire.</p>
	<p>Please notice the assembly location of electric wiring plug, electric plug should be the water-proof plug. Assembly location of electric plug must be over 0.5m (19.7in) above the floor, and far away from shower, bathtub, otherwise it might cause electricity leakage.</p>
	<p>When installing this product, please remove the old hose assemblies owned by users and install them with new hose assemblies. Do not reuse the old hose assemblies to avoid related safety problems.</p>
	<p>The grounding wire of this product must conform to the stipulated construction mode, and the three-level grounding structure must be grounded, otherwise the use of this product is prohibited.</p>
	<p>Electric plug need to plug in the electric with air switch.</p>
	<p>In the same room where this product is installed, a switch of water inlet angle valve needs to be installed at a location within reach. It is used in emergency situations to cut off the waterway of this product without the aid of tools; otherwise, unexpected failures of this product may occur and it will cause user loss.</p>
<p>If you have not used this product for a long time, please close the angle valve, press the water release button to drain the water of ceramic itself and cut off the power; When using the product again, please wash first to prevent water quality problems and skin diseases.</p>	
<p>When the outside air temperature is lower than 0°C, in order to prevent water leakage caused by external filter and other accessories likely freezing, please be sure to close the water inlet valve and drain the left water; If pipe has been frozen, please raise the room temperature and wait for pipe normal then use the toilet, otherwise the product may not be used normally.</p>	

NOTE: Drawings may not exactly define contour of the product.

## Component List

### SMART TOILET

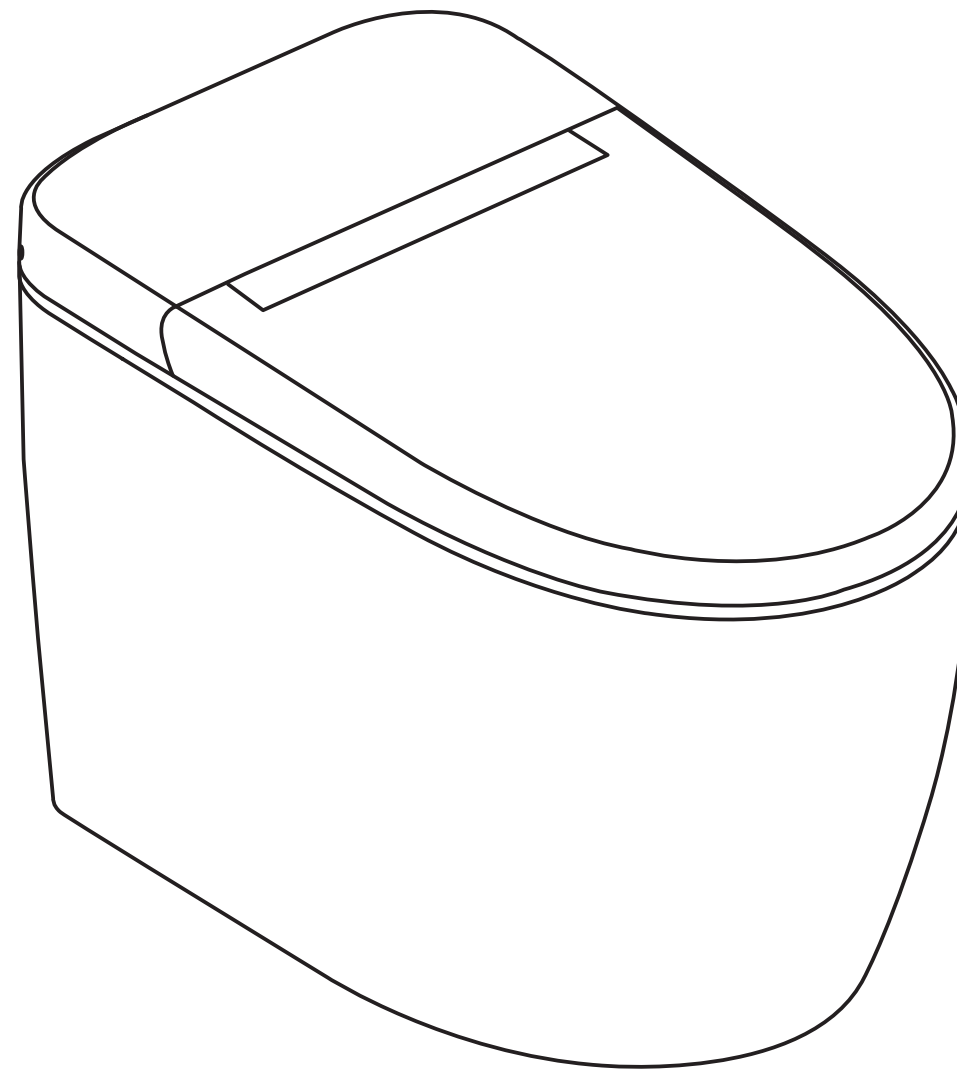

### SEALING RING

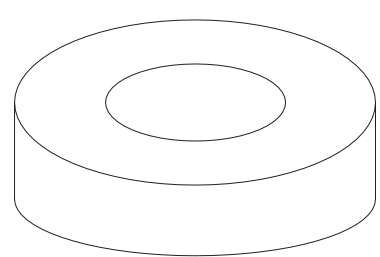

### TEFLON TAPE

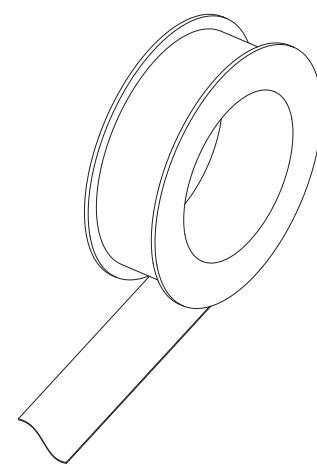

### 15/16-14UNS ADAPTER

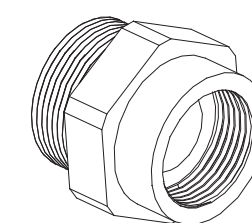

### USER MANUAL

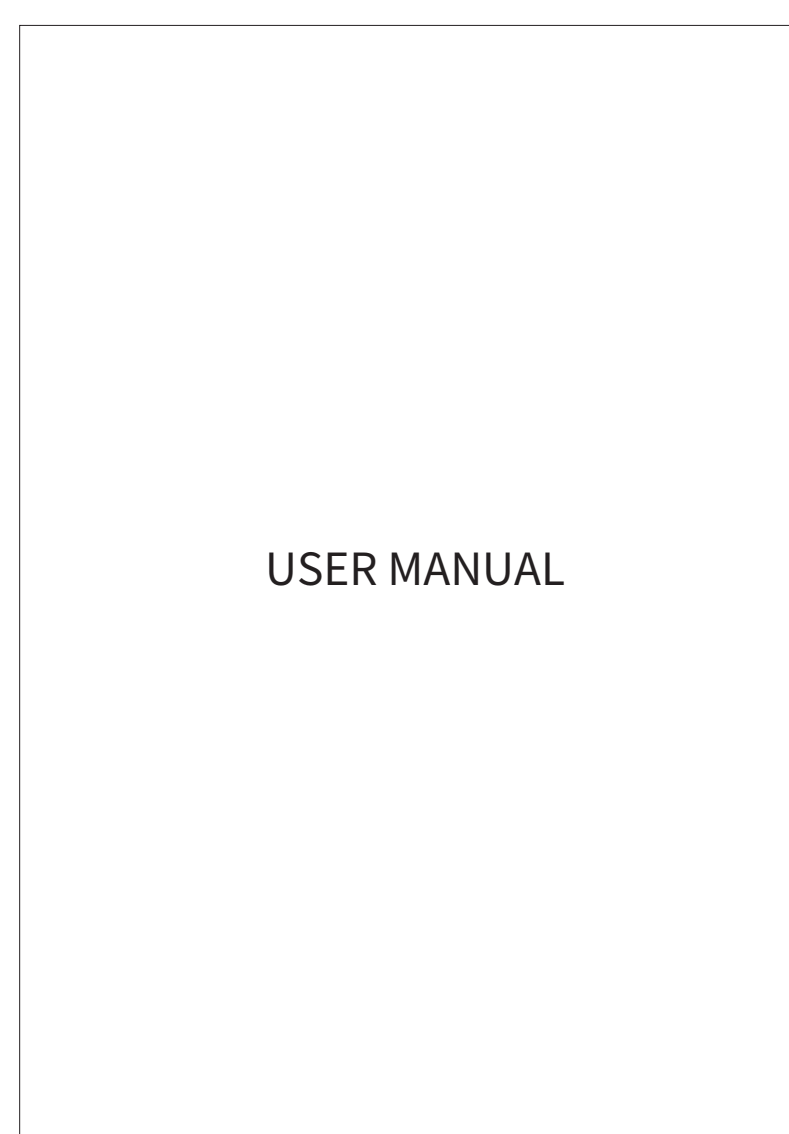

### INLET VALVE

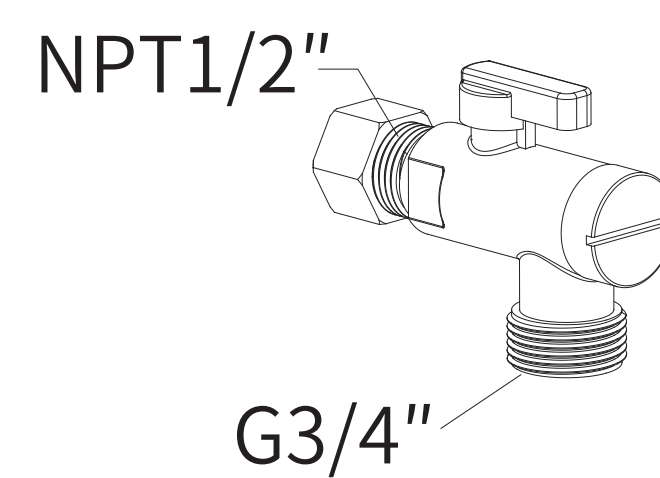

NOTE: Drawings may not exactly define contour of the product.

## Specifications

Rated voltage		120V~ 60Hz			
Power cord length		About 1.2m (49 in)			
Seat	Surface temperature	4 levels adjustable, room temperature about 107°F			
	Safety device	Thermal fuse			
Toilet	Flush consumption	1.28Gpf/4.8Lpf			
	Flushing mode	Siphon jet			
	Rough-in	305mm (12.0 in)			
Rated power	63W	Maximum power	70W	Waterproof level	IPX4
Water supply temperature	39°F-95°F	Ambient temperature	37°F-104°F	Net weight	About 34.7kg (about 76.5 lb)
Dimension	About 680 * 390 * 443 mm (About 26.8 * 15.4 * 17.4 in)	Water supply pressure	Minimum necessary dynamic pressure: 23.2Psi (flow rate 20L/Min) Maximum static pressure: 108.7Psi		

- **Rated power:** Set the seat temperature to the highest level under the conditions of an ambient temperature of 68°F±41°F, inlet water static pressure 26.1Psi ±2.9Psi, Turn on the flush function, and test the average power within 60 seconds.
- **Maximum power:** Set the seat temperature to the highest level under the conditions of an ambient temperature of 73°F±35°F, an inlet static pressure of 26.1Psi ±2.9Psi, Turn on the flush function and continue to work stably at the maximum power for a cleaning cycle.
- **Water consumption test:** Test the water consumption separately under the water pressure 23.2Psi and 80Psi three times. Get six values in total, then divide the sum by six and the average is the nominal water consumption.

NOTE: Drawings may not exactly define contour of the product.



## Function Table

Category	Function	
Comfort	Seat heating	●
	Seat ring temperature adjustment	●
	Soft close seat & lip	●
Human care	Night light	●
	Foot sensor control flush	●
	Automatic flush	●
	Flush with power failure	●
	Flushing water pressure	●
	Eco mode	●
	Washing in advance	●
Safety	Air isolation channel backflow prevention	●
	Multi-layers Safety Protection	●
	Nano glaze	●
	Self diagnosis	●
	Preventing Low-Temperature Scalds	●

NOTE: Drawings may not exactly define contour of the product.

## Parts Names

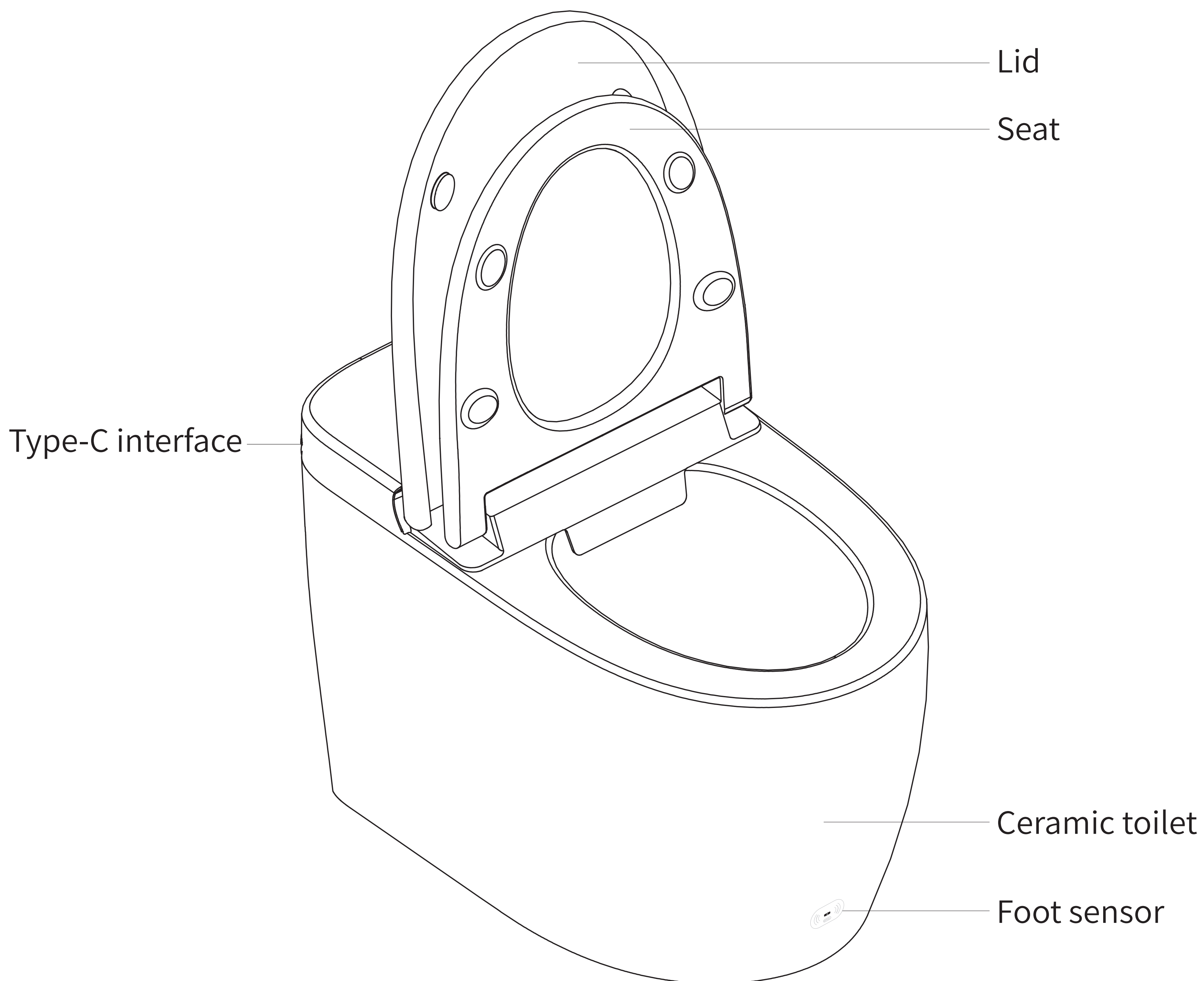

NOTE: Drawings may not exactly define contour of the product.

## Product Drawings

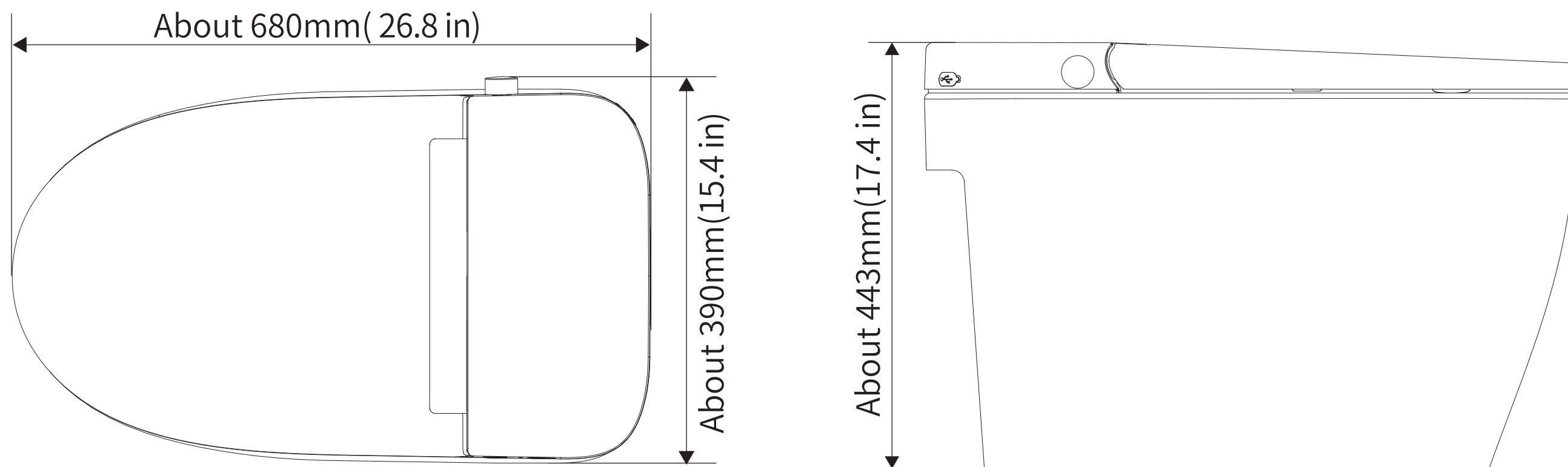

## Power and Water Supply Connection

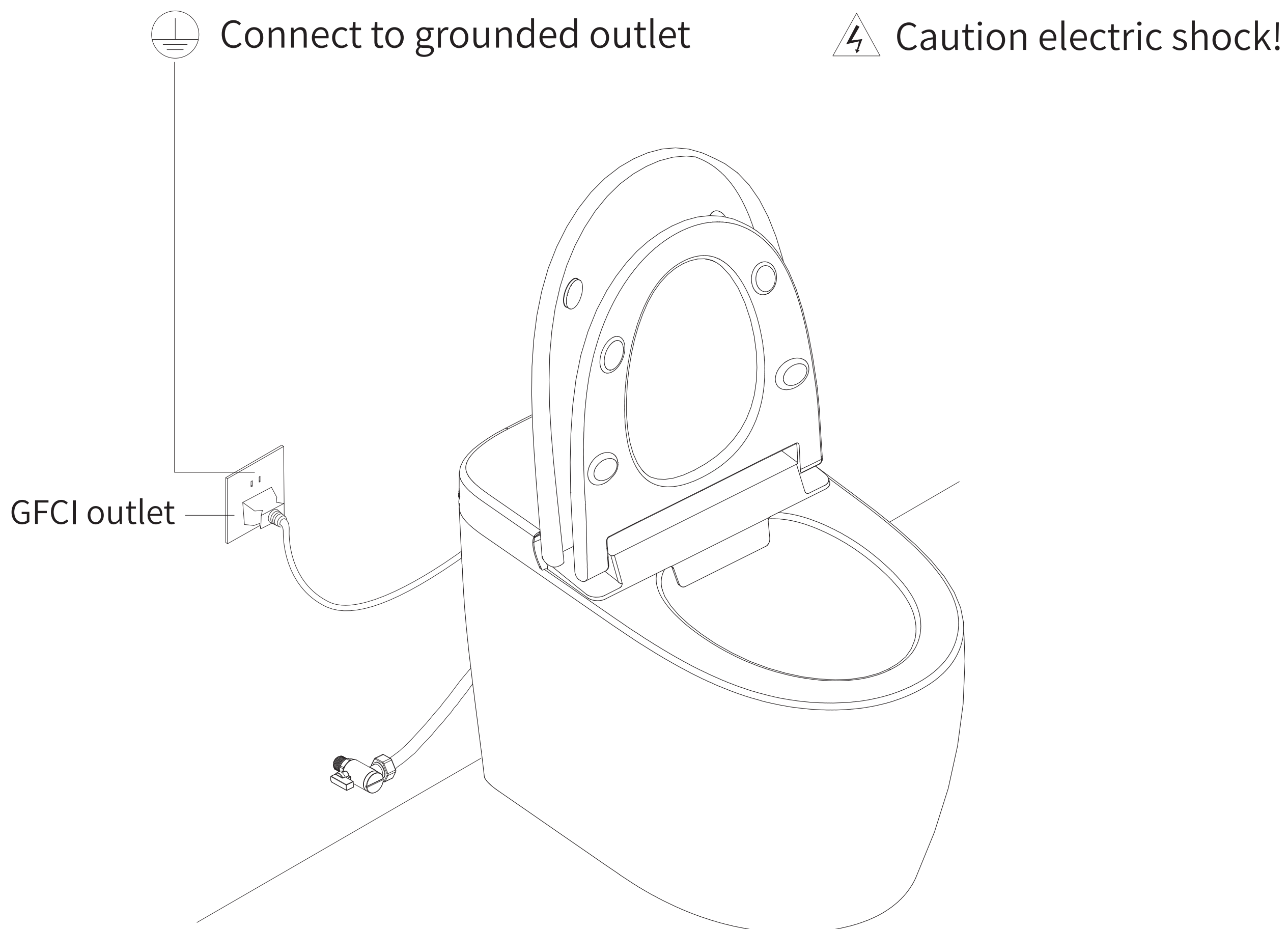

- If the power cord is not long enough, please use extension line which is made by certificated manufacturers.
- Only for reference.

NOTE: Drawings may not exactly define contour of the product.

## Installation Precaution

We reserve the right to change, update, modify, alter, redesign this manual and product without prior notice. We shall not be liable for any injuries or property damages in connection with improper installation or use of the product.

## Installation Tools

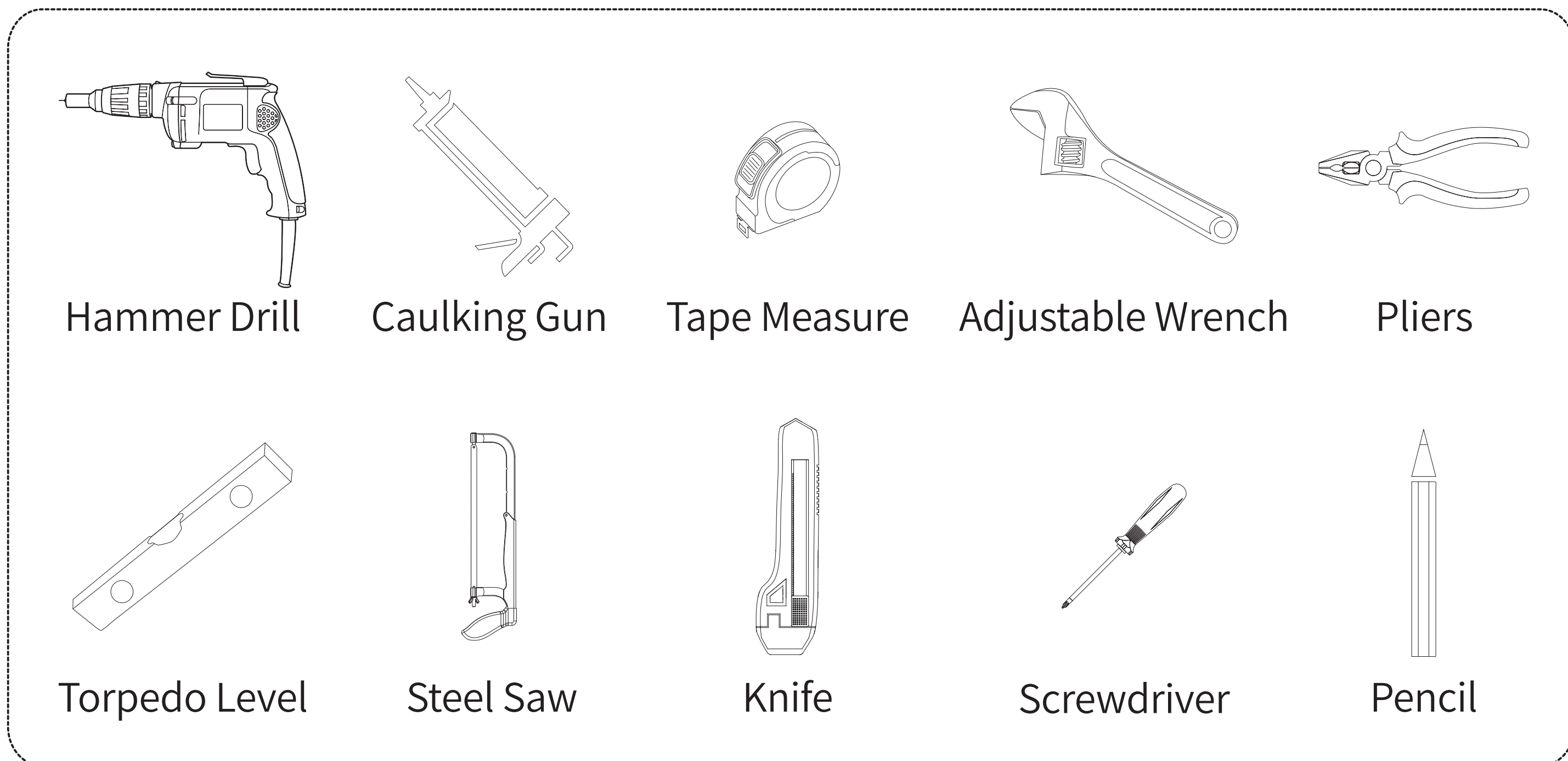

## Confirmation of Water Pressure

- The minimum dynamic operating water pressure is 23.2 Psi, and the maximum static water pressure is 108.7 Psi.

### Determination method for minimum water flow

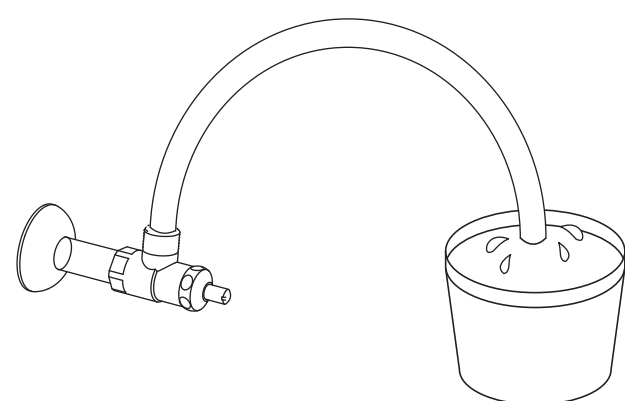

(Tools: stopwatch, measuring cup.)

Open the angle valve for water supply. The measured water flow for 10 seconds should exceed 3.34L. If the above conditions cannot be met, the best flushing effect cannot be achieved and an additional booster pump is required to increase the pressure.

NOTE: Drawings may not exactly define contour of the product.

## Product Installation

### 1. Install the inlet valve

Clean and dry the ground before installation. Mark the draining outlet central lines and install the inlet valve on the wall.

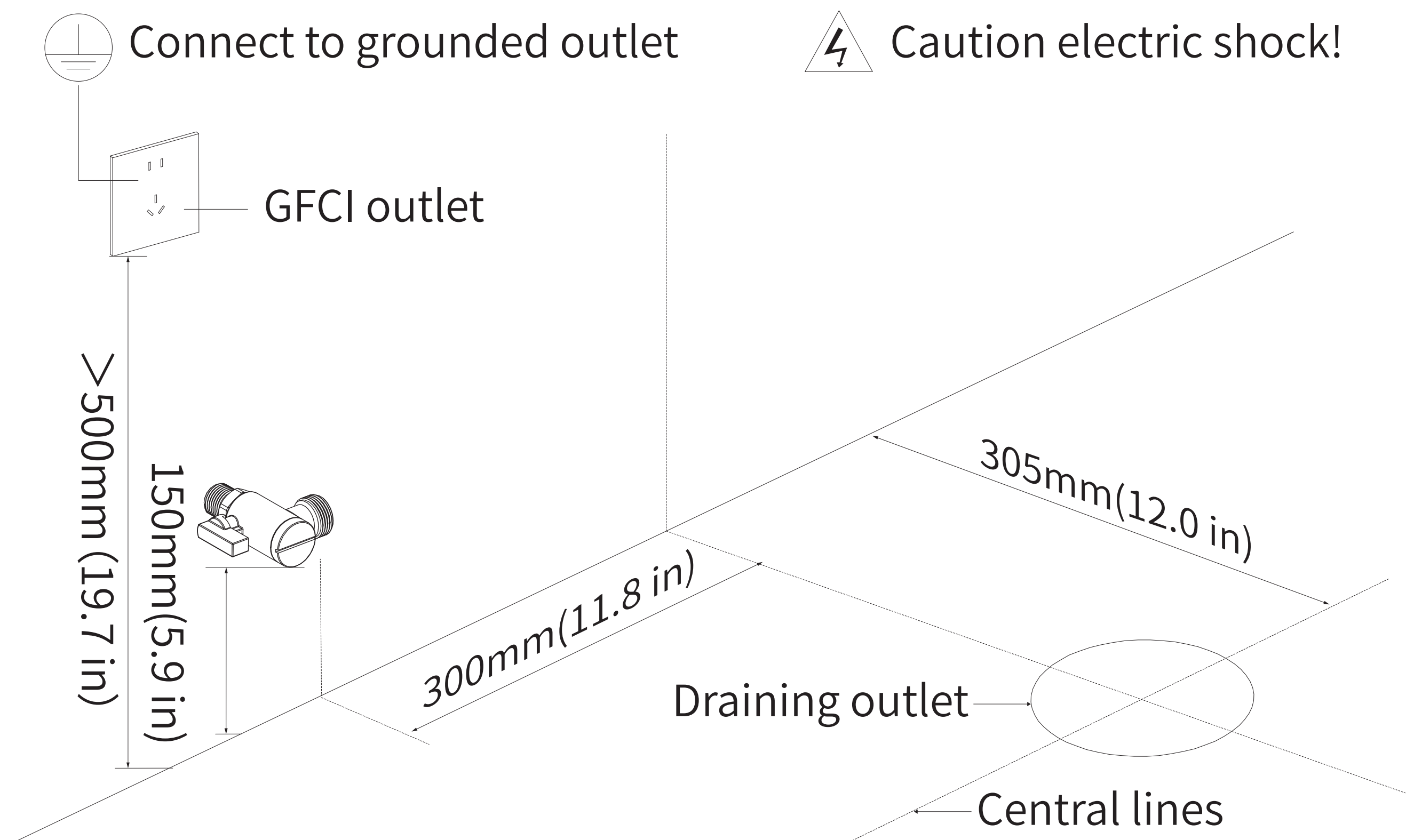

### 2. Mark the curve of the toilet

Align the toilet draining outlet with the central line. Mark the curve of the toilet for later installation.

Glue the outline with silicone sealant.

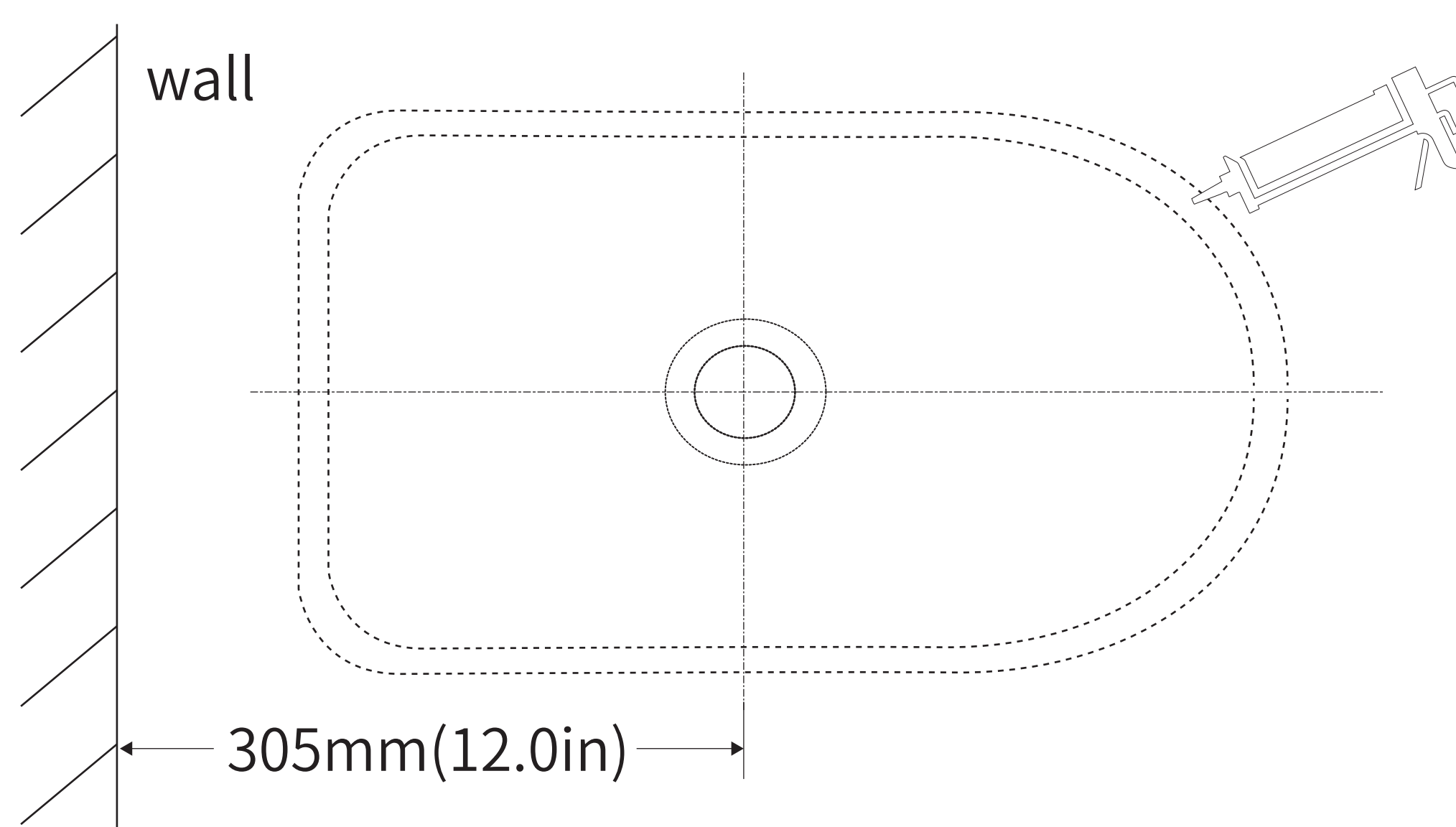

NOTE: Drawings may not exactly define contour of the product.

## Product Installation

### 3. Toilet installation(Method 1)

#### ① Sealing ring installation

Gently tilt the toilet sideways.

Install the sealing ring evenly along the outlet, make sure the small end of the sealing ring face the toilet.

Glue the edge of toilet bottom with silicone sealant, place the toilet along the marked outline.

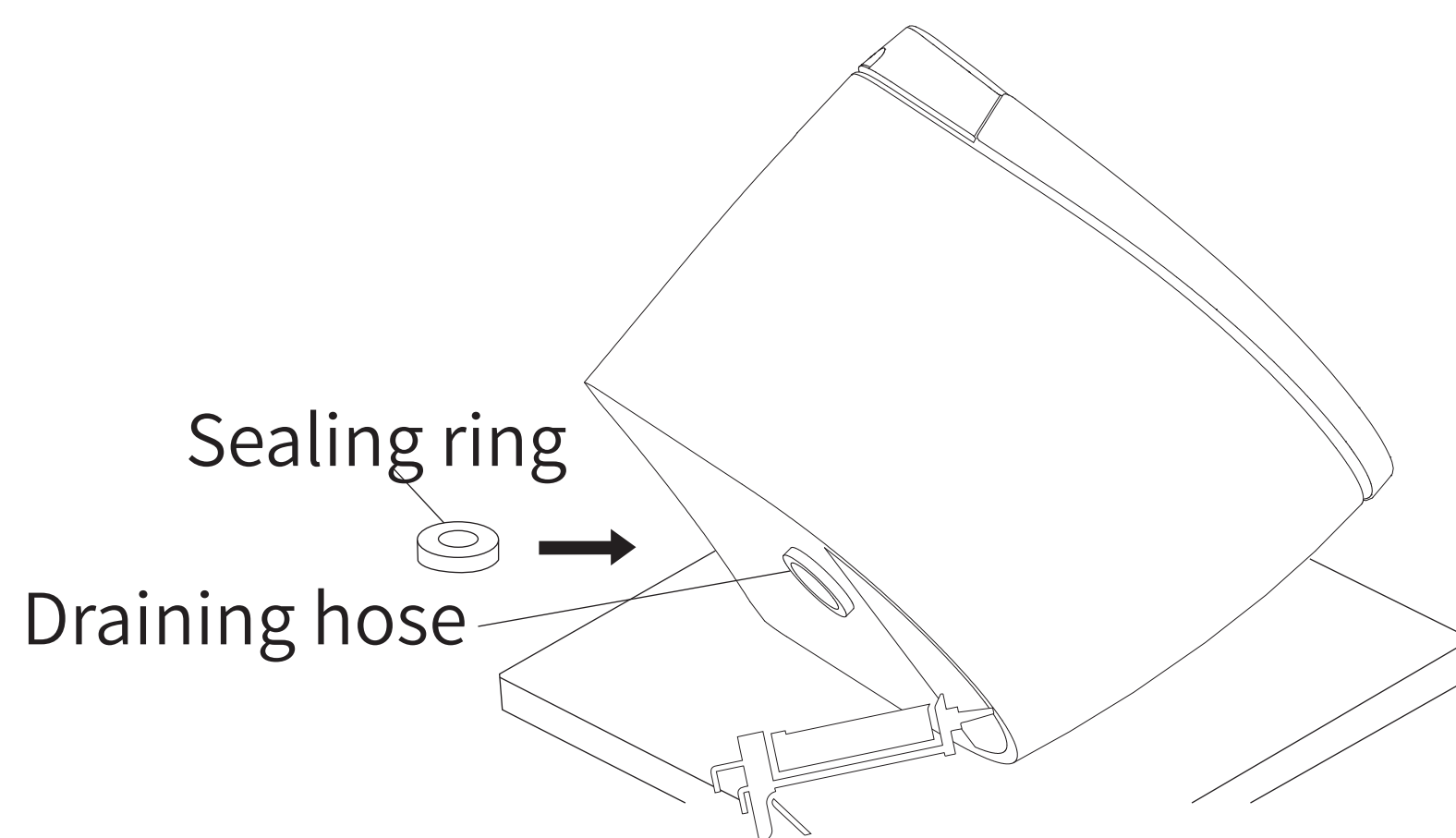

#### ② Toilet (ceramic) installation

Align the toilet with the outline drawn on the ground, and slowly put it down. After overlapping, press the toilet to make the sealing ring fully sealed.

Do not move or shake the toilet left and right after installation, otherwise the sealing ring may be damaged and cause water leakage.

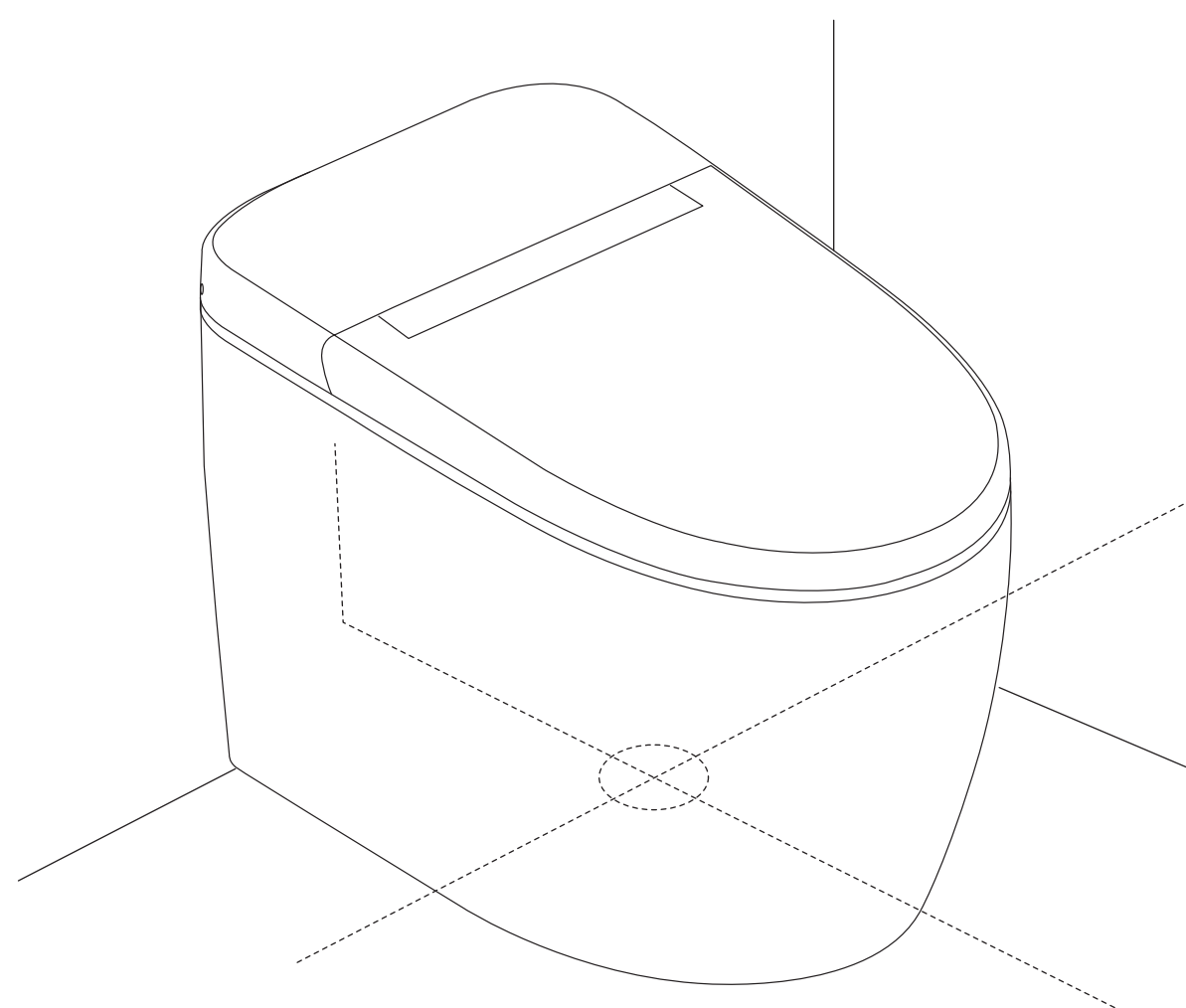

NOTE: Drawings may not exactly define contour of the product.

## Product Installation

### 4. Toilet installation(Method 2)

#### ① Remove the bidet seat

Remove the fixing screws, disconnect the hoses, then separate the bidet seat from the toilet.

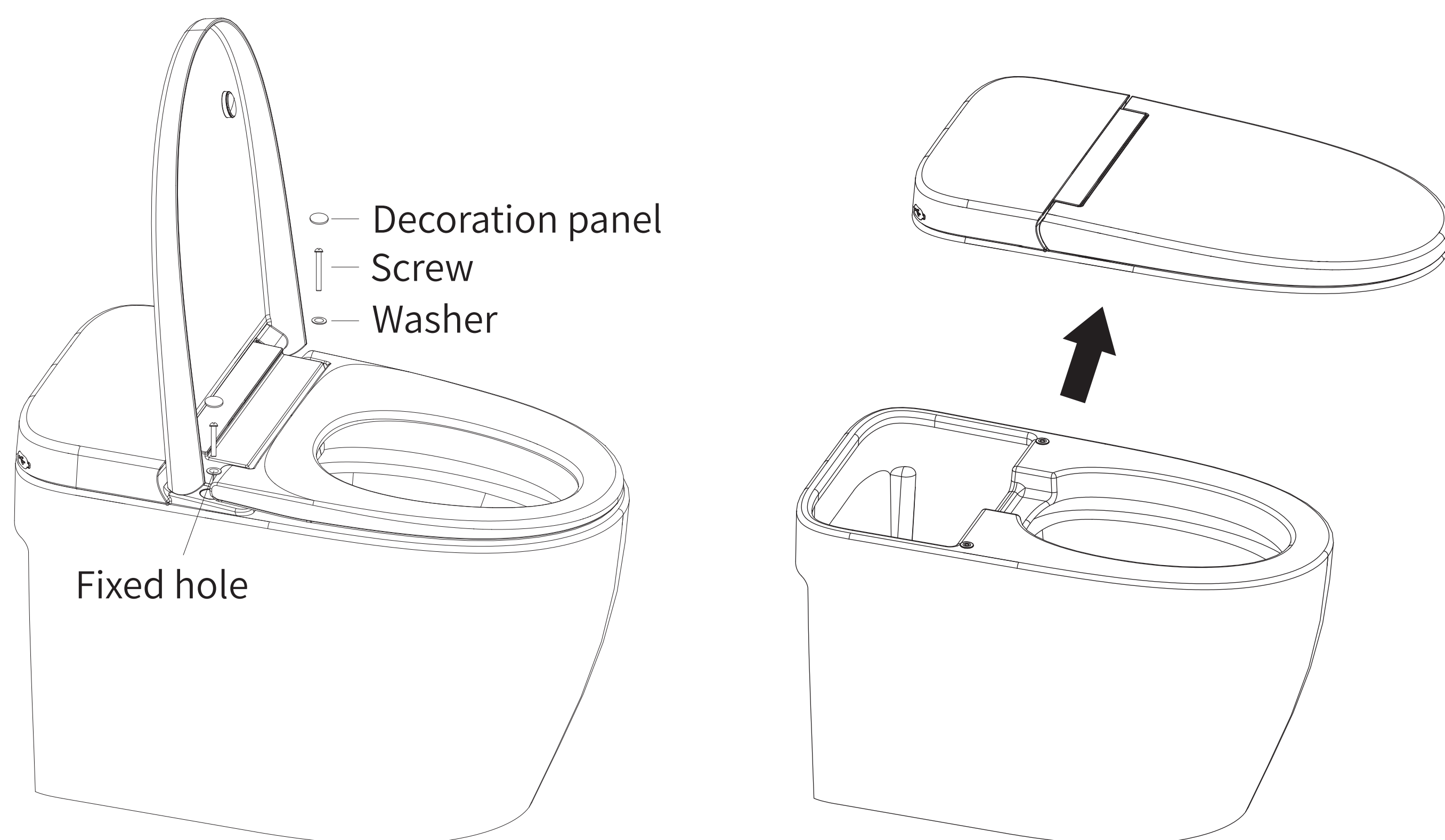

#### ② Sealing ring installation

Place the sealing ring onto the flange.

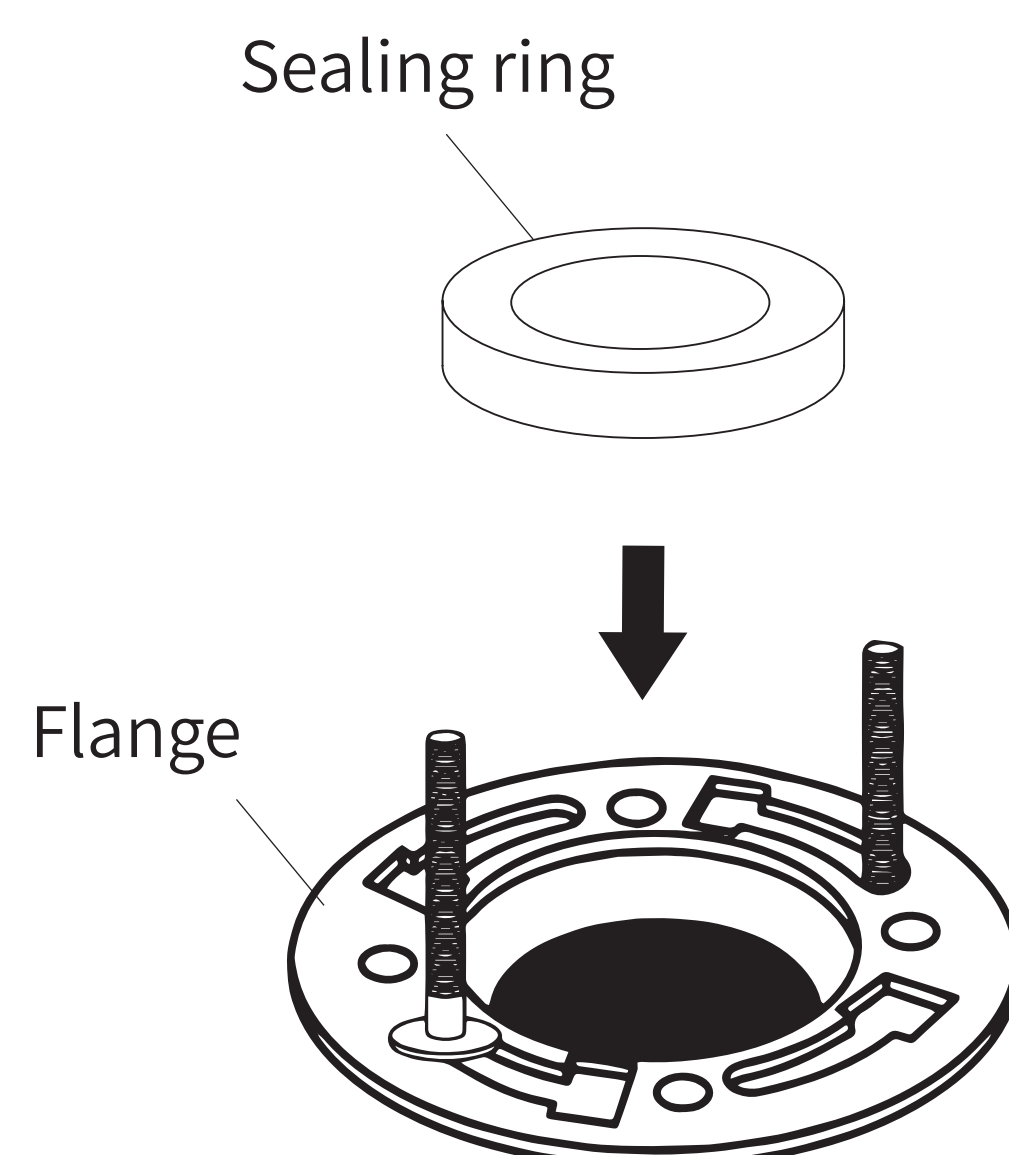

NOTE: Drawings may not exactly define contour of the product.

## Product Installation

### ③ Toilet(ceramic) installation

Glue the edge of toilet bottom with silicone sealant

Align the toilet with the flange and screws.

Place the toilet along the outline and secure the flange bolts.

Glue the edge of toilet bottom with silicone sealant.

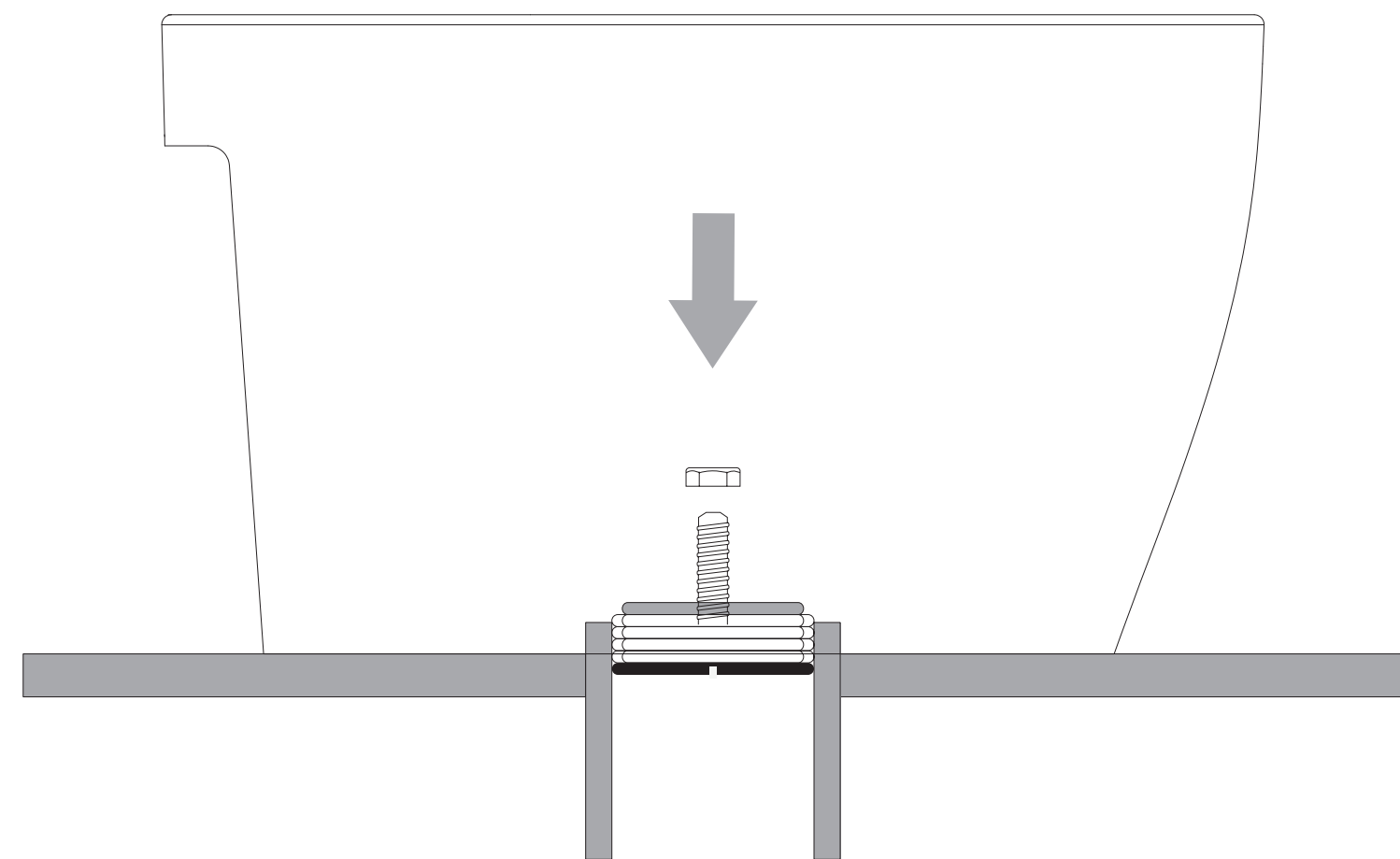
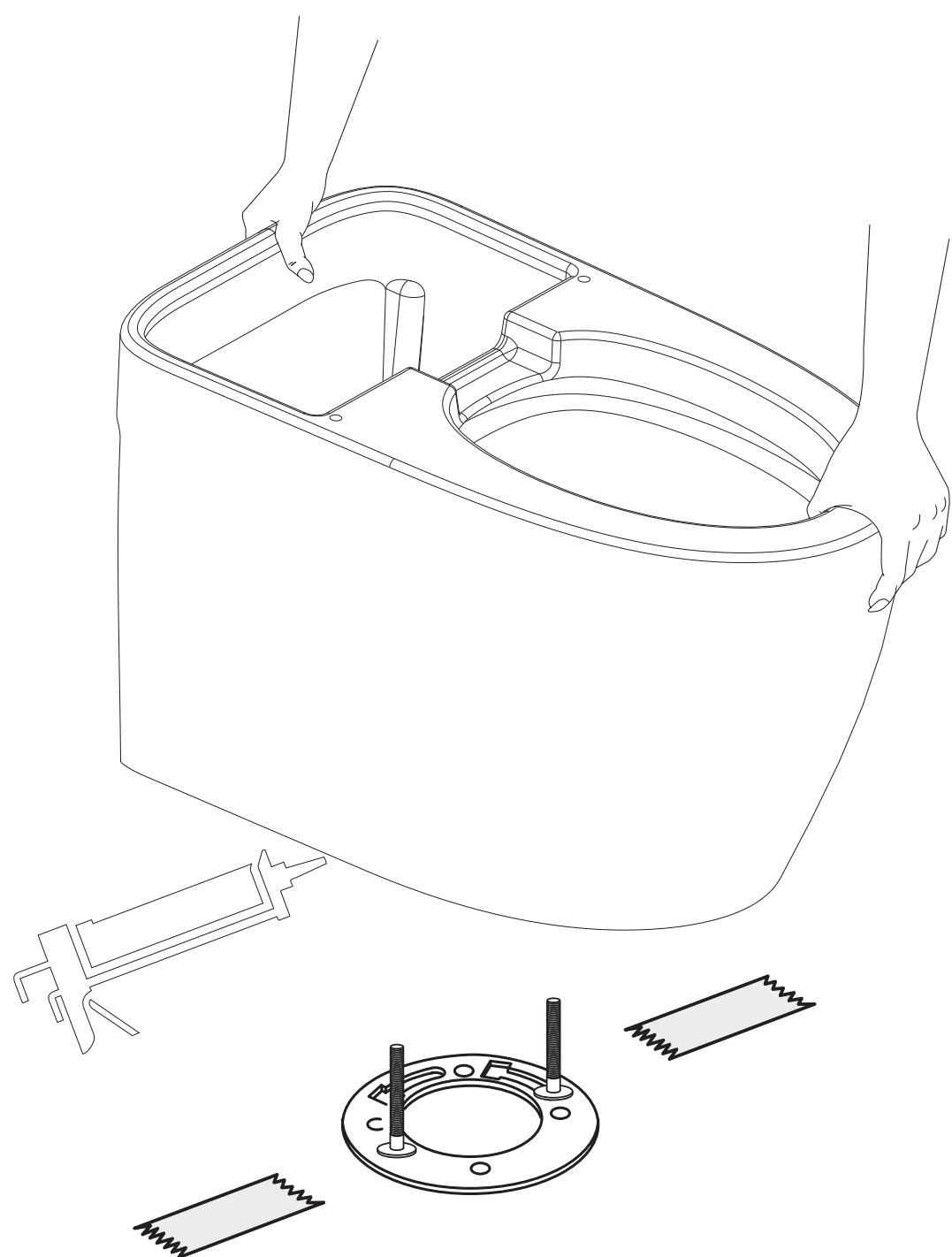

### ④ Bidet seat installation

Connect the hoses, inset the bidet seat and fix it on the toilet.

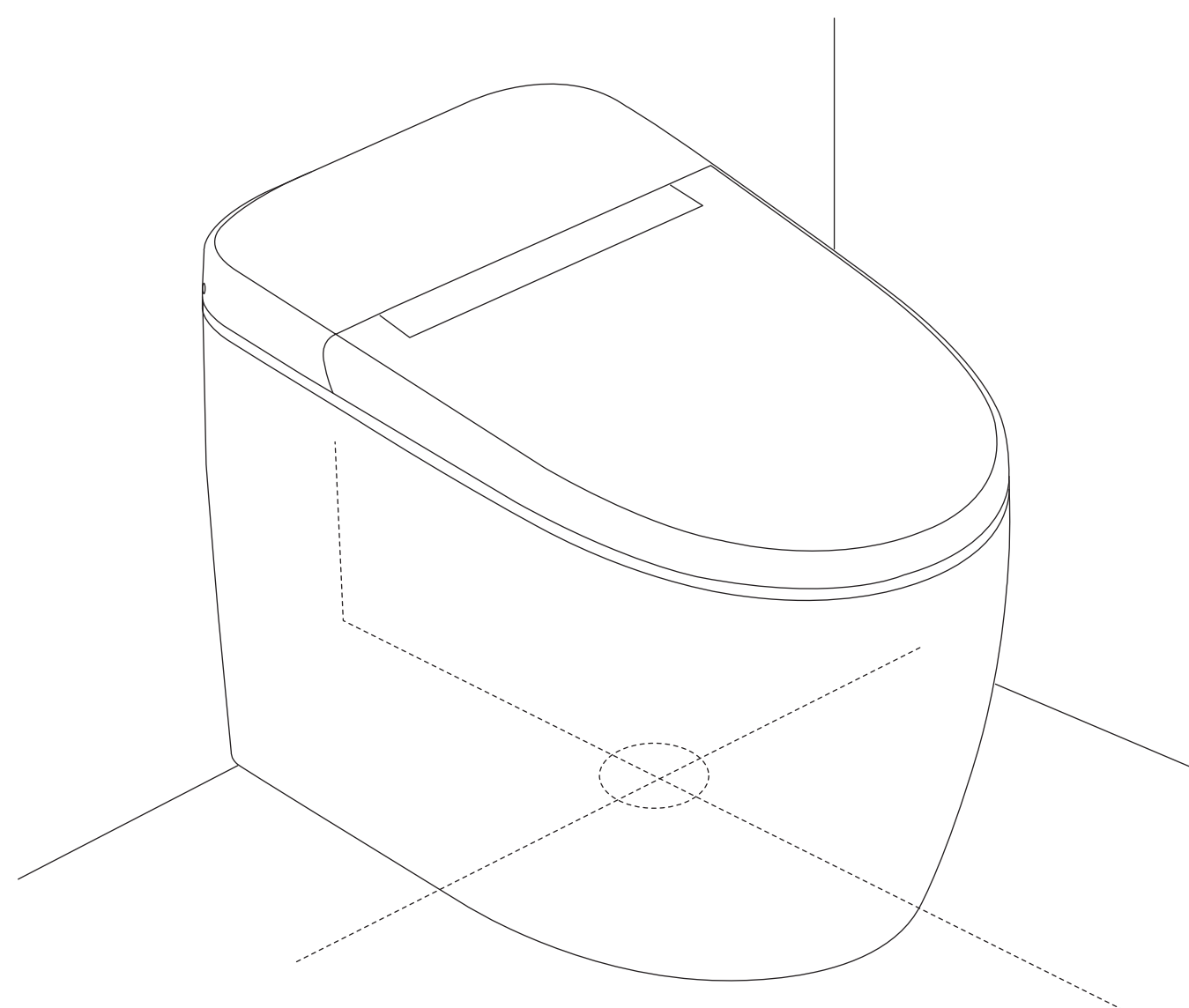
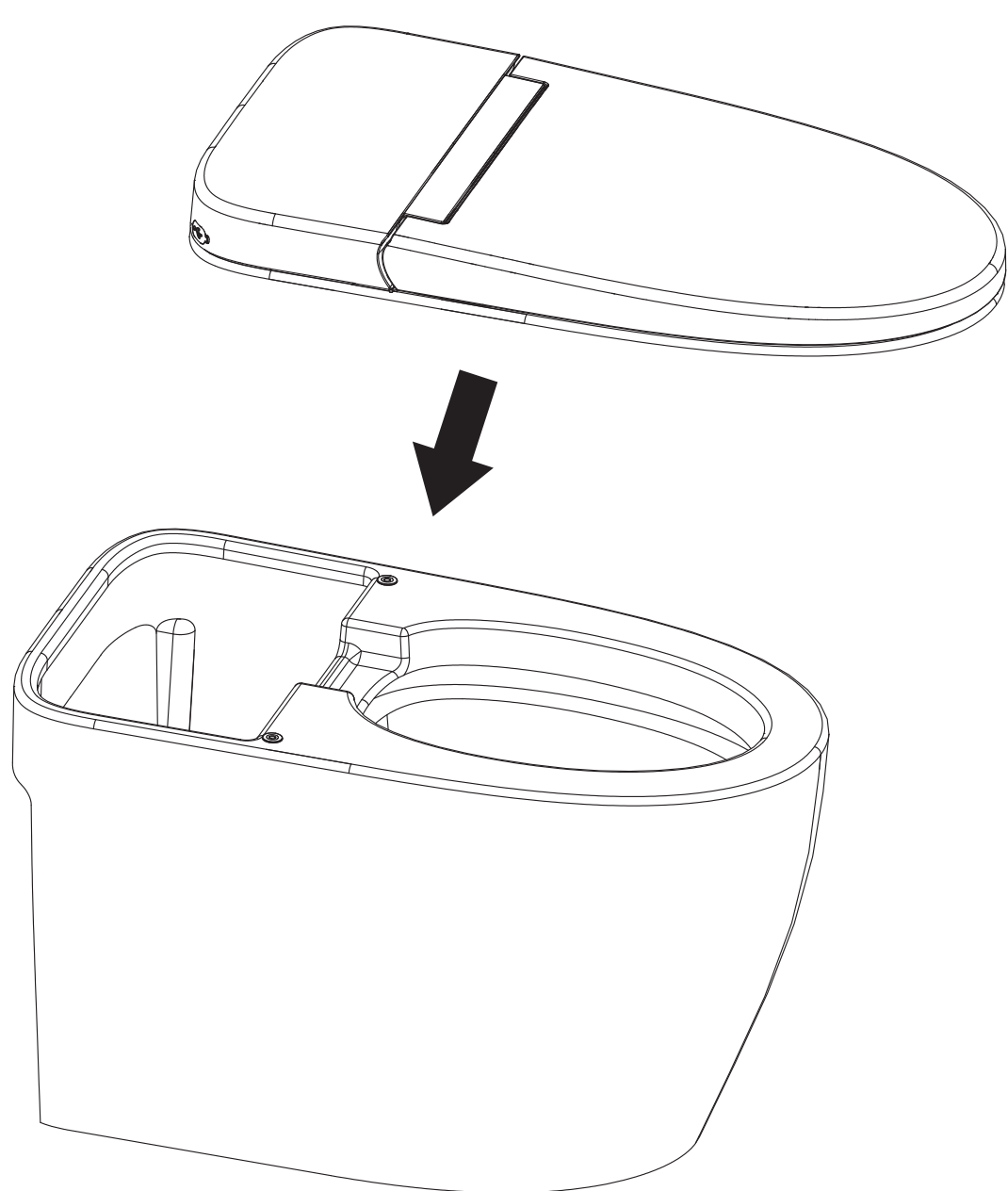

NOTE: Drawings may not exactly define contour of the product.



## Product Installation

### 5. Connect the water inlet valve and filter

As shown in the following figures.

#### NOTE:

Do not use the smart toilet immediately after installation, use it after 48 hours.

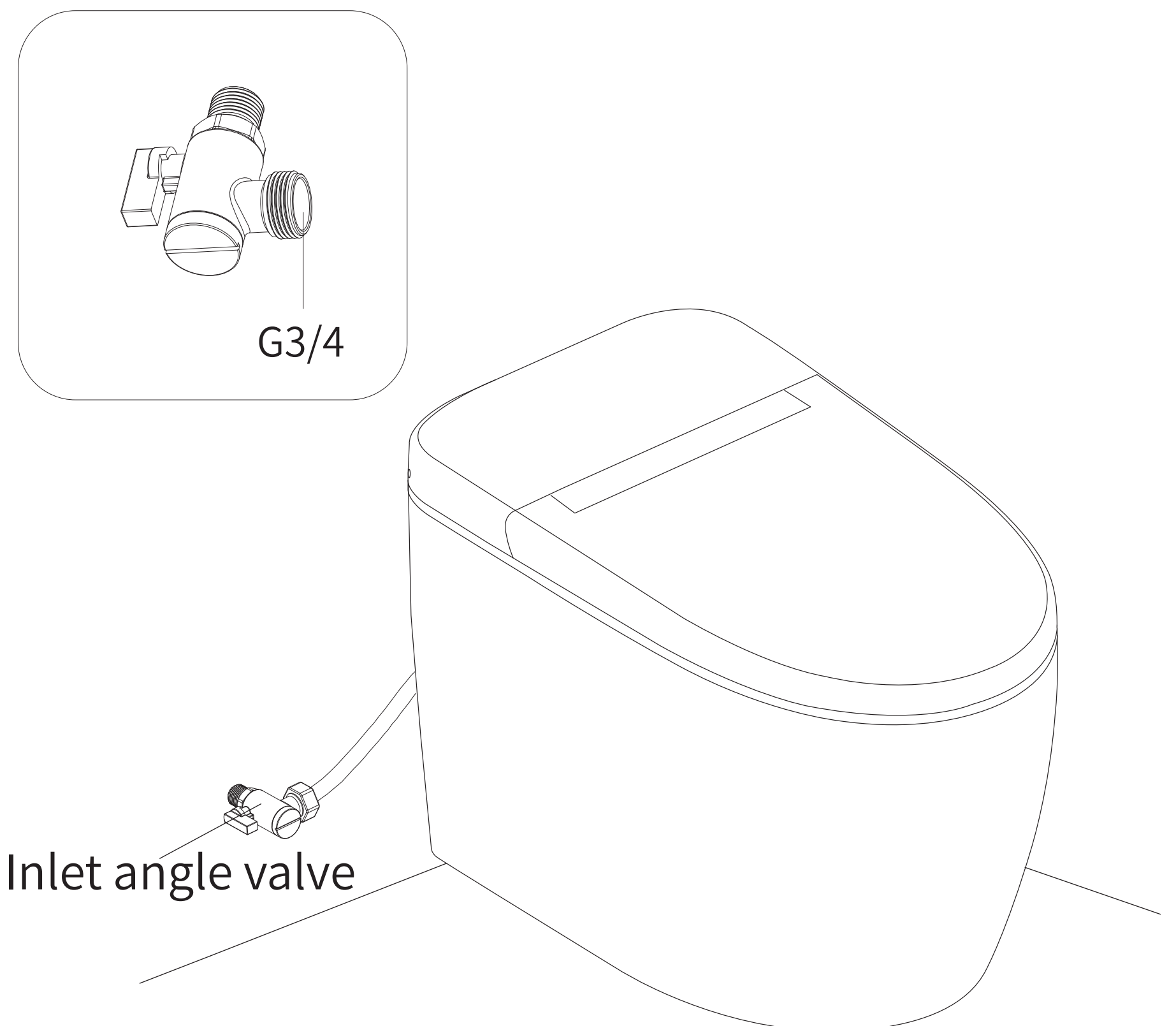
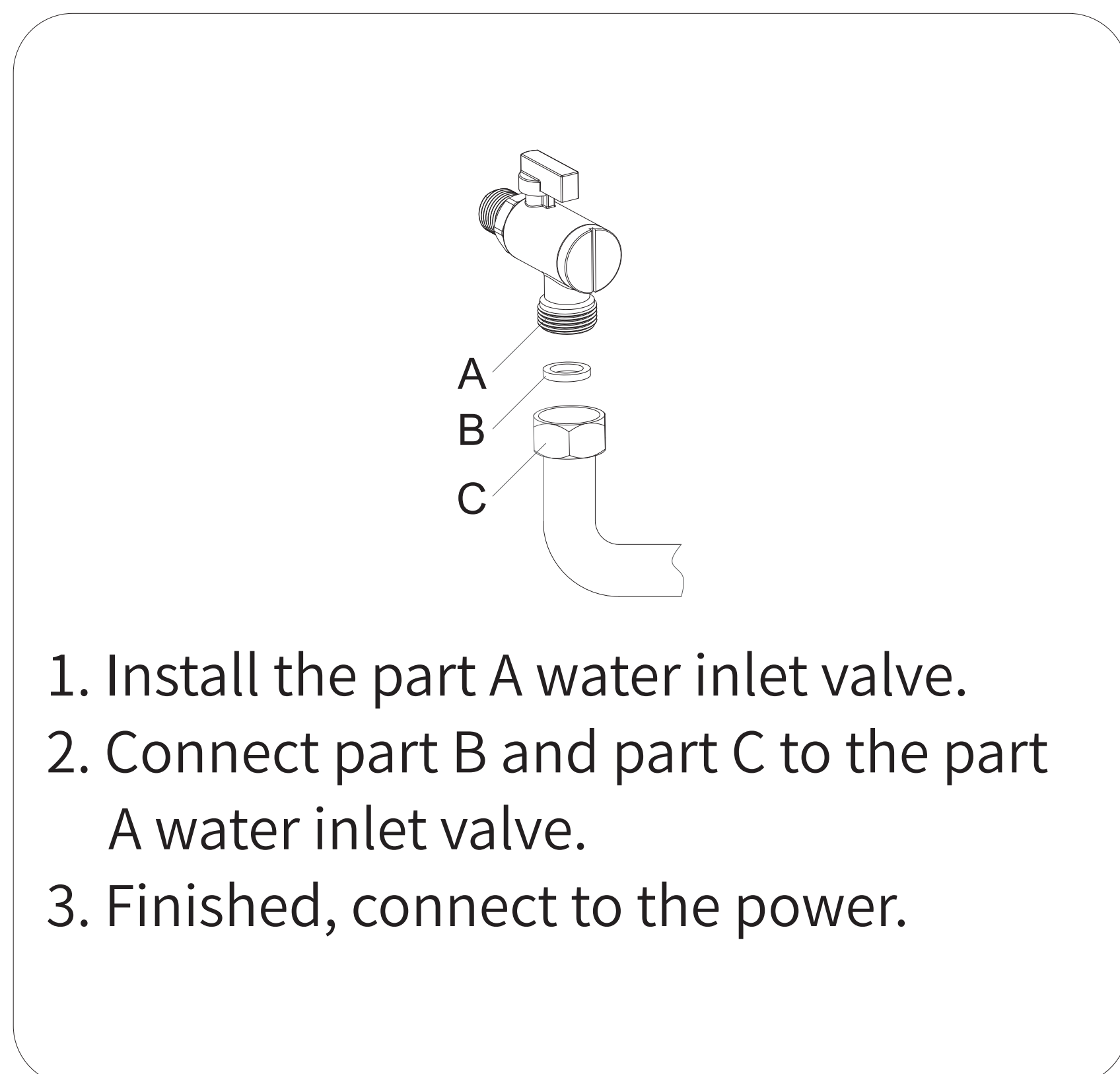

### 6. Connect to the power

Only connect this product to a properly grounded outlet.

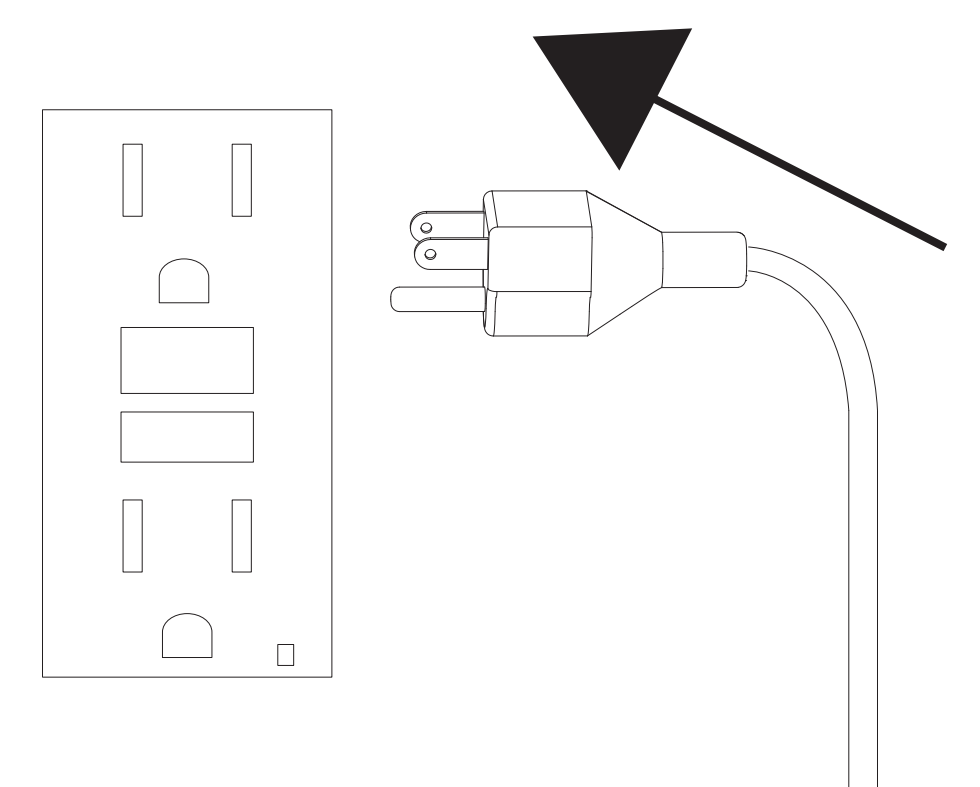

### 7. Using the product for the first time

Connect to the power and turn on the water inlet valve.

Check every function, such as seat temp adjustment, flushing, etc.

NOTE: Drawings may not exactly define contour of the product.

## Side Control Using Instructions

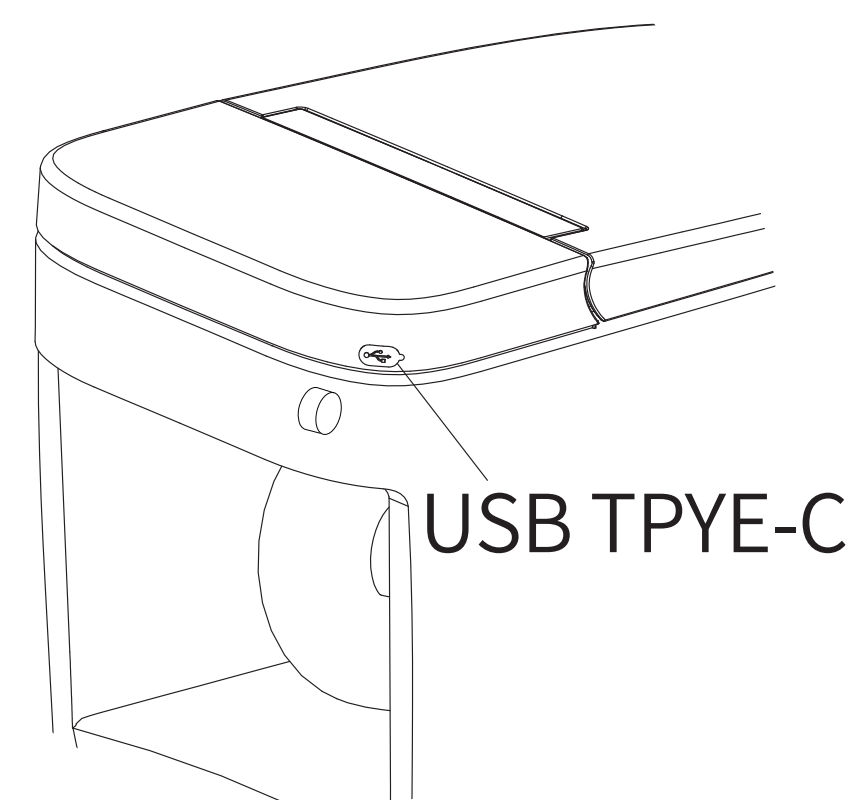
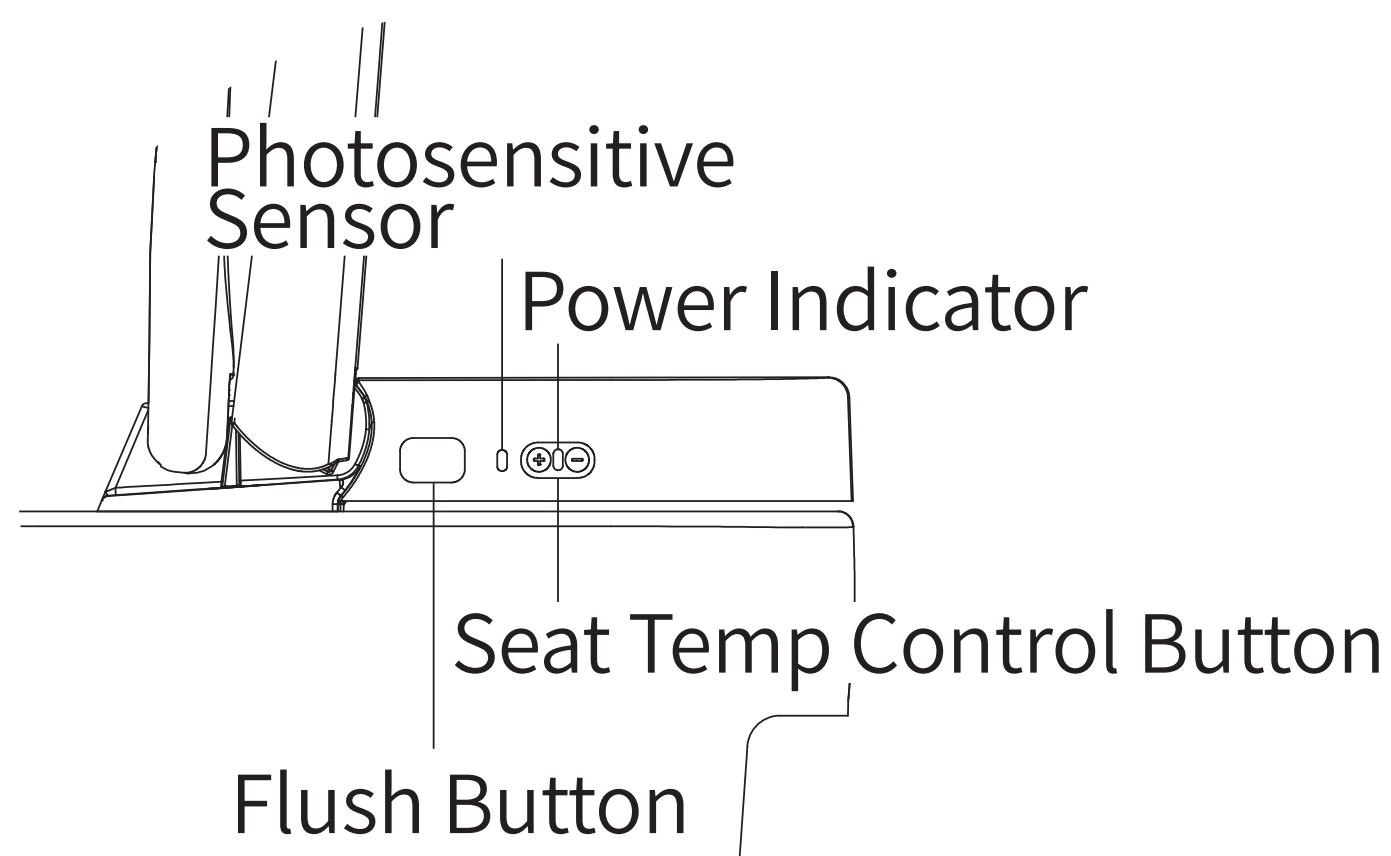

### Seat temp adjustment

The seat temperature can be adjusted by shortly pressing the "+" or "-" of the seat temp control button.

### Flushing

The flushing function can be turned on by shortly pressing the flush button.

### Auto nightlight

The auto nightlight function can be turned on or off by long pressing the "-" button under unseated state.

### Auto flushing after leaving seat

The auto flushing function can be turned on or off by long pressing the flush button and "-" button at the same time under unseated state.

### Kicking flushing

The kicking flushing function can be turned on or off by long pressing the flush button and "+" button at the same time under unseated state.

### Power outage flushing

Using mobile power to access the USB TPYE-C interface of the toilet in case of power outage. After that, you could use it normally.

### ECO

The ECO function can be turned on or off by long pressing the "+" button, at the same time under unseated state. After leaving the seat for 30 minutes, the seat temperature drops to 1st Level.

## Other Functions Instruction

### Kick sensing

Gently touch the foot sensor to activate the auto flushing function.

### Pre-wetting

Once sitting on the seat, the pre-wetting function will be activated to help reduce waste build-up.

NOTE: Drawings may not exactly define contour of the product.

## Maintenance and Cleaning

### Maintenance and cleaning of toilet lid and seat

1. Turn off the power, close the water outlet valve.
2. Use soft cloth to clean the lid and seat.

Be careful not to allow water to get inside or leave detergent in the gap between the top unit and the bowl unit.

Avoid using materials that will damage the surface. Clean the surface with a soft and wet cloth.

Corrosive chemicals or cosmetics (such as cleaners containing abrasive compounds and aftershave) can not be used to clean the lid and seat.

3. Turn on the power, open the the water outlet valve.

### Maintenance and cleaning of the toilet bowl

1. Turn off the power.
2. Use toilet brush and toilet detergent to clean the bowl.

Corrosive chemicals (such as cleaners containing abrasive compounds and strongly acidic cleaners or strong alkaline cleaners) should not be used to clean the bowl.

Wire brush or abrasive nylon scrubbing brush should not be used to clean the bowl.

3. Turn on the power.

## Cleaning The Water Filter

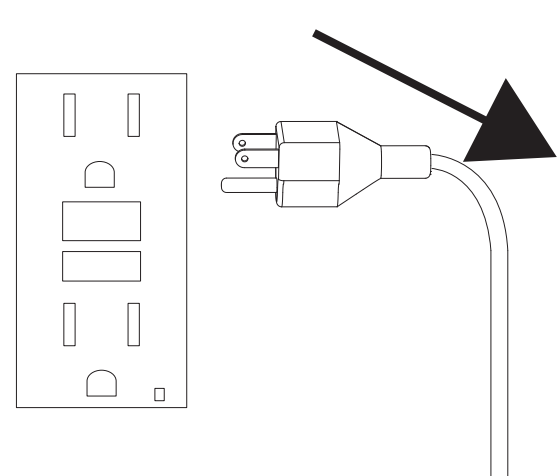

- ① Turn off the power  
Close the water outlet valve.

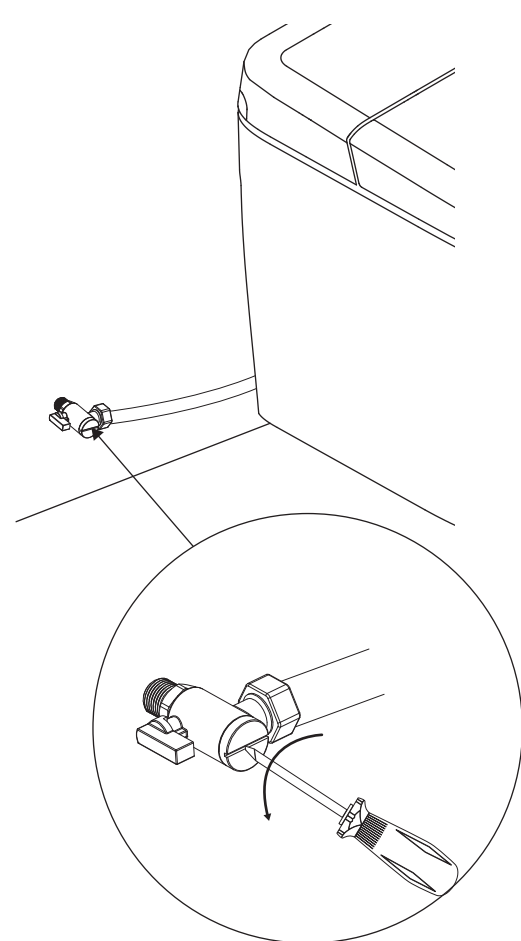

- ② Remove the water-inflow filter from the inlet hose.
- ③ Take out the filter by using a flat-blade screwdriver to unscrew the filter .

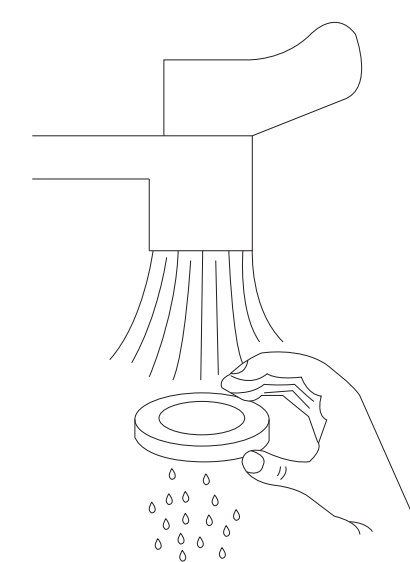
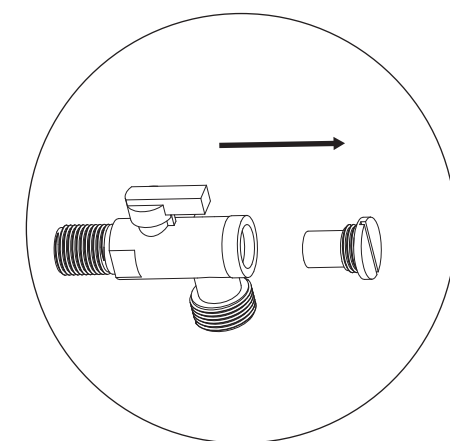

- ④ Remove the filter and rinse it with clean water.
- ⑤ Install the filter screen as it is, be sure to tighten it, otherwise it will cause water leakage.

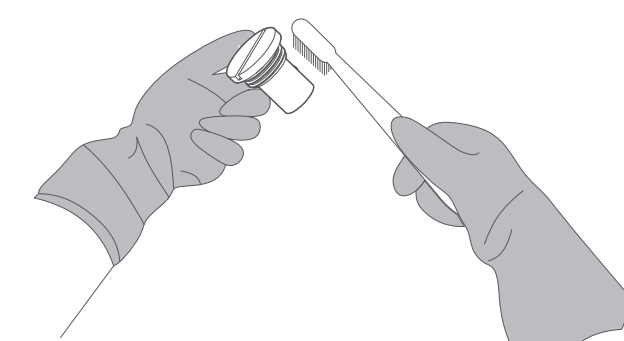

NOTE: Drawings may not exactly define contour of the product.

## How to Do?

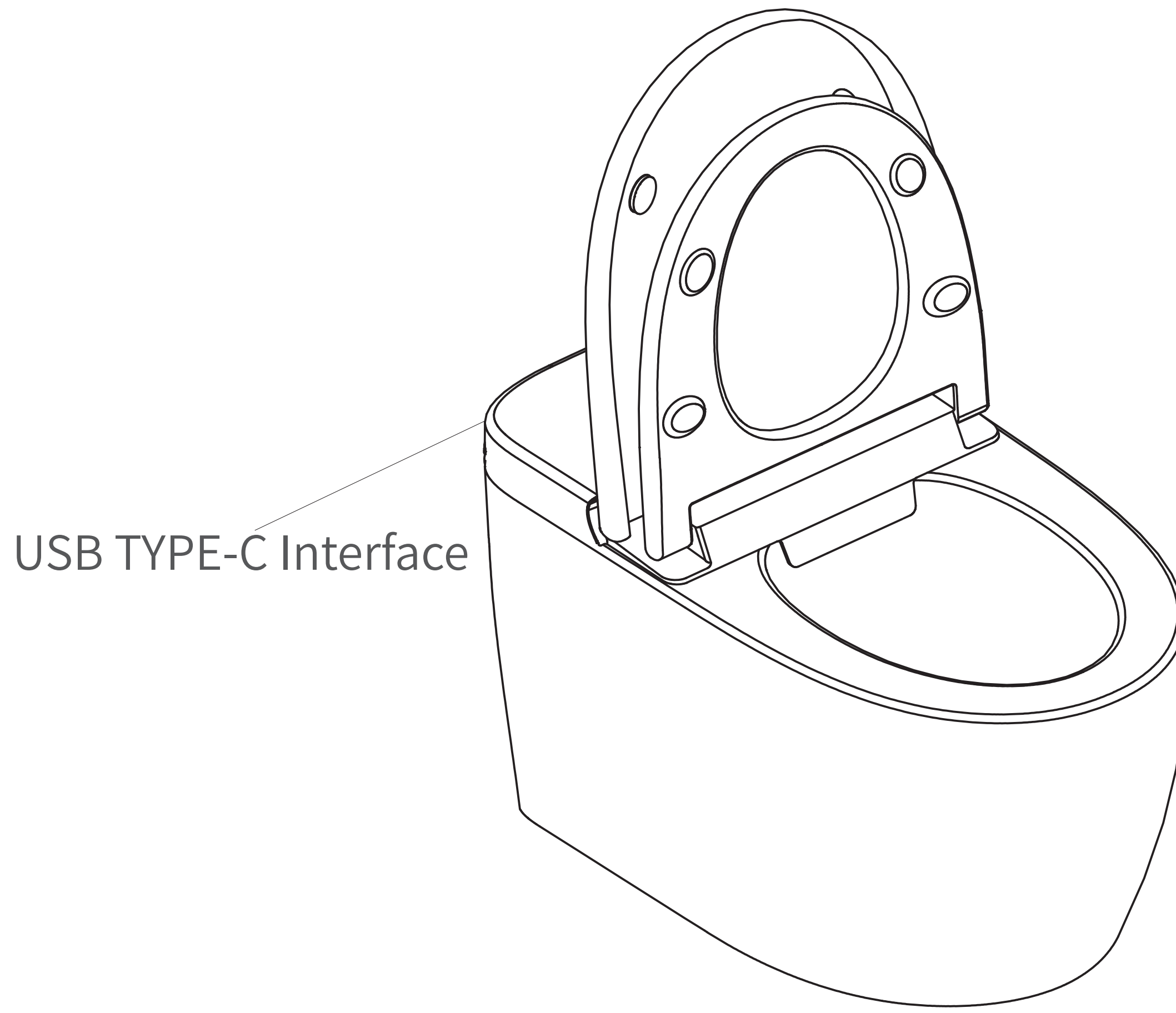

### 1. When the toilet can not flush automatically due to power outage.

Connect the smart toilet with power bank through the TPYE-C interface.

### 2. When the toilet can not flush automatically due to water outage.

- ① Flush the sewage in the toilet away with basin.
- ② After flushing, add water to the toilet to avoid stinking.

### 3. When the product is left unused for long time

- ① Turn off the power, and close the Angle valve, drain the water in the inlet hose.
- ② Especially in winter, the water inside the hose of the toilet should be discharged to avoid freezing.

NOTE: Drawings may not exactly define contour of the product.

## Troubleshooting

Phenomenon	Reasons	Measures
The product out of work	Whether the power supply is plugged in.	Insert the plug or detect the power socket.
	Power outage.	Wait until the power supply restored.
Water comes out unexpectedly from the inlet hose.	The inlet hose is defect.	Replace the inlet hose.
The toilet seat does not get warm.	The seat sensor does not sense someone sitting.	Sit on the toilet seat properly.
	Low seat temperature.	Use the side control to adjust seat temperature.
The toilet does not flush.	Water is not available from the water supply.	Taking water to flush.
	The water supply valve is not fully open.	Check the Angle valve.
The sewage can not be flushed away completely.	The water supply valve is not fully open.	Check the Angle valve.
	The water filter is clogged.	Clean the filter.
	The water supply pressure is weak.	Check the water supply.
	Flushing may be difficult due to the consistency of the waste material.	Flush the toilet again. If the bowl is not cleaned with a flushing, remove the stains with a brush or other tools.
There is residue on the bowl unit surface.	Oil and other hard-to -see grime may stick to the bowl unit surface.	Clean the bowl with a non-abrasive toilet detergent.
LED light doesn' t turn on.	The indoor light is too bright.	Please turn off the indoor light and close the curtain.
The top unit is unstable.	There is clearance between the toilet seat cushion and the bowl.	It' s common phenomenon.
Water is leaking from pipe joints.	Pipe joints are loose.	Tighten the hose.
	Pipe joints keep leaking.	Close the water outlet valve and replace a new hose.

### ● Notice

When facing an issue, carefully review the common troubleshooting provided above, and follow the solution instructions for product maintenance. Reach out for assistance by contacting professional maintenance personnel, dealers, or the DeerValley after-sale service team promptly.

Please be aware that discrepancies may exist between the contents of this manual and the actual product, and in such cases, the details of the actual product should take precedence.

NOTE: Drawings may not exactly define contour of the product.

## Maintenance Service Sheet

Product		Product code	
The selling store		Purchase date	
Province	City	Dealer (signature):	
Maintenance content			
<p><b>Free Maintenance Regulation:</b></p> <p>1. We warrant our products to be free from defects in materials and workmanship during normal use when properly installed and serviced, for a period of one (1) year from date of purchase. This limited warranty is extended only to the ORIGINAL PURCHASER of the product and is not transferable to any third party, including but not limited to any subsequent purchaser or owner of the product. This warranty applies only to our product is purchased and installed in USA and Canada.</p> <p>2. The obligations under this warranty are limited to repair, replacement or other appropriate adjustment, at our option, of the product or parts found to be defective in normal use, provided that such product was properly installed, used and serviced in accordance with instructions. We reserves the right to make such inspections as may be necessary in order to determine the cause of the defect.</p> <p>3. This warranty does not apply to the following items:</p> <p>a) Damage or loss sustained in a natural calamity such as fire, earthquake, flood, thunder, electrical storm, etc.</p> <p>b) Damage or loss resulting from any accident, unreasonable use, misuse, abuse, negligence, improper care, or maintenance of the product.</p> <p>c) Damage or loss resulting from sediments or foreign matter contained in a water system.</p> <p>d) Damage or loss resulting from the quality of water in the region where the product is used.</p> <p>e) Damage or loss resulting from improper installation or from installation of the product in a harsh and/or hazardous environment, or improper removal, repair or modification of the product.</p> <p>f) Damage or loss resulting from electrical surges or lightning strikes or other acts which are not the fault of the product or which the product is not specified to tolerate, including failure to use the factory equipped cord and plug or use of a loose or faulty electrical outlet or use of a current or socket other than a 120V, 60Hz electrical current from a GFI (ground, fused) socket.</p> <p>g) Damage or loss resulting from normal and customary wear and tear, such as gloss reduction, scratching or fading over time due to use, cleaning practices or water or atmospheric conditions, including but not limited to, the use of bleach, alkali, acid cleaners, dry (powder) cleaners or any other abrasive cleaners or the use of metal or nylon scrubbers.</p>			
<p>Executive standard: CONFORMS TO UL STD. 1431/UL STD. 1591 ASME A112.4.2-2021</p> <p>Warranty period: within one year from the purchase date</p>			

- Due to the constant improvement about our products, we will keep the final interpretation of products change.
- If the products you bought exist differences from the instruction, please in kind prevail.



**NOTE:** This equipment has been tested and found to comply with the limits for a Class B digital device, pursuant to Part 15 of the FCC Rules. These limits are designed to provide reasonable protection against harmful interference in a residential installation. This equipment generates uses

and can radiate radio frequency energy and, if not installed and used in accordance with the instructions, may cause harmful interference to radio communications.

However, there is no guarantee that interference will not occur in a particular installation. If this equipment does cause harmful interference to radio or television reception, which can be determined by turning the equipment off and on, the user is encouraged to try to correct the interference by one or more of the following measures:

- Reorient or relocate the receiving antenna.
- Increase the separation between the equipment and receiver.
- Connect the equipment into an outlet on a circuit different from that to which the receiver is connected.
- Consult the dealer or an experienced radio/TV technician for help.

**NOTE:** Drawings may not exactly define contour of the product.

## LIMITED WARRANTY COVERAGE

### 2-YEAR LIMITED WARRANTY

DeerValley products are made with quality materials and excellent craftsmanship to provide customers with a long-lasting product. If any defects in materials or craftsmanship are found under normal use within the first two years of delivery, DeerValley will provide replacement parts at no charge or, at its option, replace any product or part of the product deemed defective under normal installation, use, service, and maintenance. This warranty applies only to the original purchaser. Proof of purchase will be required to process any claims. **SCRATCHES ARE NOT COVERED UNDER WARRANTY.**

The manufacturer warrants this product to be free of manufacture defects during the above mentioned warranty time. Please keep a copy of the original invoice as proof of purchase.

DeerValley will, as its option, (1) repair or replace the defective part(s) or product(s) at no charge; (2) issue a refund of the original purchase price of the product(s) (Valid within 30 days from the date of delivery); or (3) issue a credit to be applied toward the purchase of a new DeerValley product shipping/delivery charges may apply and are in DeerValley sole discretion.

DeerValley recommends the installations to be made by a licensed, professional plumber. DeerValley will not be held responsible for any damage or product failure due to improper installation, misuse, or failure to use a licensed professional. DeerValley is not responsible for any removal or installation cost.

This limited warranty shall not apply to goods which have been subject to accident, negligence, improper installation, product abuse, product misuse, or use of cleaners containing abrasives, alcohol or other organic solvents, whether performed by a contractor, service company, or yourself, are excluded from this warranty.

DeerValley responsibility under this limited warranty is limited to only to replacement parts and no other costs. DeerValley will not be responsible for labor charges and/or damage incurred by installation, repair or replacement, nor for any indirect incidental or consequential damages, losses, injury or costs of any nature relating to this product Except as provided by law, this limited warranty is in lieu of and excludes all other warranties, conditions, and guarantees, whether expressed or implied, statutory or otherwise, including without restriction those merchantability of fitness for use.

### RESPONSIBILITIES OF OTHERS

Inspecting the unit prior to installation is the responsibility of the installer or building contractor who acts on behalf of the user. They are responsible for ensuring the unit is free of defect or damage.

Notices are placed on and in the unit and on the shipping carton advising the installer of this responsibility.

In the event of a problem, the unit must not be installed. DeerValley is not responsible for failures or damage that could have been discovered, repaired, or avoided by proper inspection and testing prior to installation.

Damage occurring in transit is the responsibility of the carrier. The user or installer **MUST** open the crate and inspect the unit for damage when it is delivered. If damage is discovered, it must be reported immediately to the seller and the carrier in writing, and an inspection requested. Failure of the carrier to respond should be reported to the seller and the carrier. Your freight claims should be filed promptly thereafter.

### LIMITATIONS AND EXCLUSIONS

This warranty does not cover instances of negligence, misuse, abuse, improper installation, carelessness, accident, hard water or mineral deposits, exposure to corrosive materials, misapplication, damages caused by improper maintenance, alteration of the product, or failure to follow care or installation instructions enclosed with your product. This warranty is void if the DeerValley is subject to alteration, or if repairs are attempted by anyone other than an authorized agent of DeerValley. This warranty does not extend to plumbing or components installed by dealers, installers or by any party other DeerValley.

DeerValley is not responsible for the loss of DeerValley use, inconvenience, or any incidental or consequential costs, expenses, or damages. Please be aware that in some states, the exclusion or limitation of incidental damages may not be allowed.

### DISCLAIMER

Except as expressly provided, there shall be no warranty or obligation, express or implied, oral or statutory. No dealer or other person has the authority to make any warranties or representations concerning DeerValley or its products. In no event shall DeerValley be held responsible for any such warranties or representations.

### WARRANTY SERVICE

NOTE: When requesting warranty, be sure to have the following:

- Copy of original invoice
- Date of installation
- Description and pictures of defect
- Model number or description of model

To obtain warranty service and replacement part, please contact DeerValley Customer Service. DeerValley will determine whether to repair or replace your product, issue a refund, or issue a credit.