

Tribesigns

DESIGNED FOR LIFE

Assembly Instructions

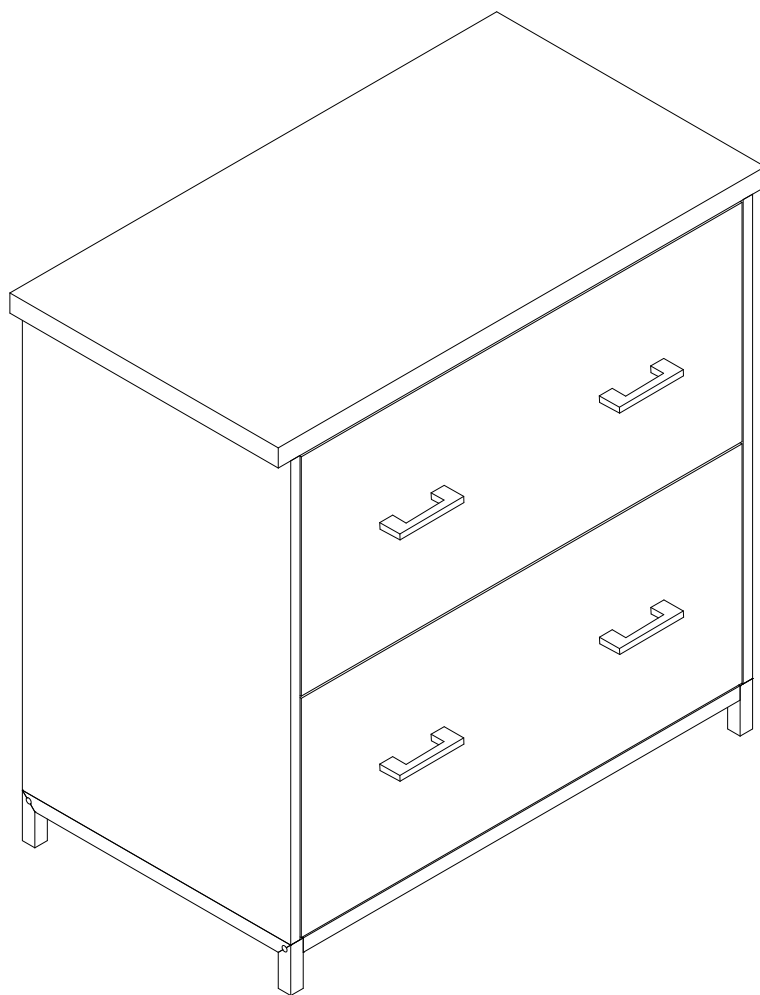

Lockers

Model No.
HOGA-HL0118

 **LITTLE TREE**
Little Tree by Tribesigns

www.tribesigns.com

Contact Us

We're here to help you.



Your satisfaction is our top priority. If you encounter any issues with this product, such as missing or damaged parts, we're here to help. Please retain the original packaging and take photos of the packaging and the product, then contact us as soon as possible.

Warm Tips

1. Carefully read these instructions and keep them for future reference.
2. Check the parts list and confirm everything's there before starting assembly.
3. When assembling, put all parts on a soft, smooth surface like a carpet to avoid scratches.
4. Don't fully tighten screws until all parts are confirmed in place to avoid misalignment.

How to Get the Assembly Video

Step 1 Scan the QR code.



Installation Video

Step 2 Search with the Model No. (on the bottom left corner of the title page)

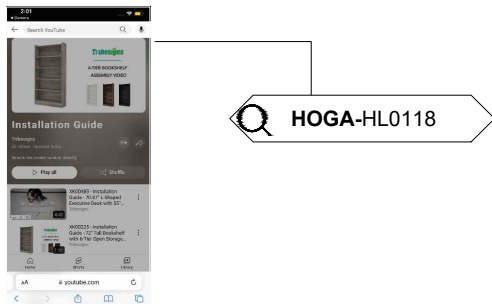

HOGA-HL0118

Note: If you can't find the assembly video, please contact us.

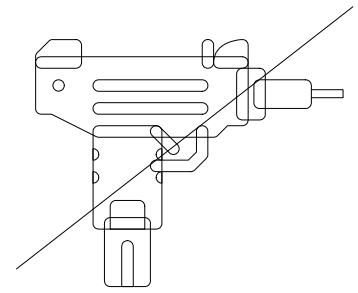
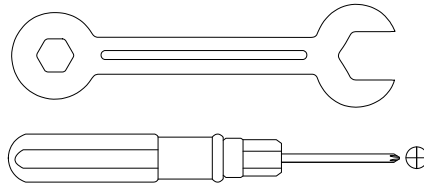
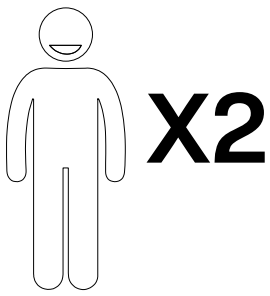

We recommend using hand tools for assembly.

If an electric screwdriver is used, reduce power and torque to avoid damage to the product.

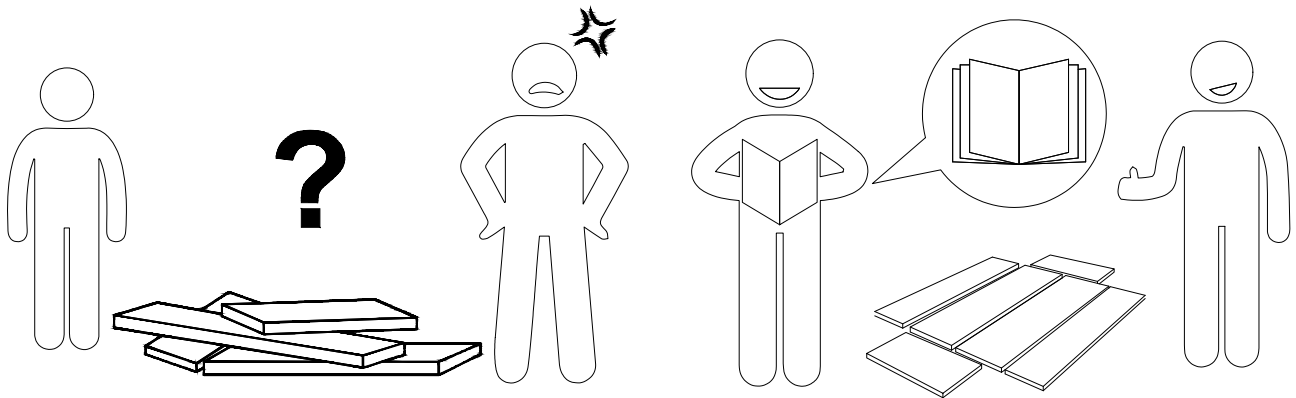

Install the Anti-Tip Straps

Using the anti-tip straps can reduce the risk of tipping over but can not eliminate it.

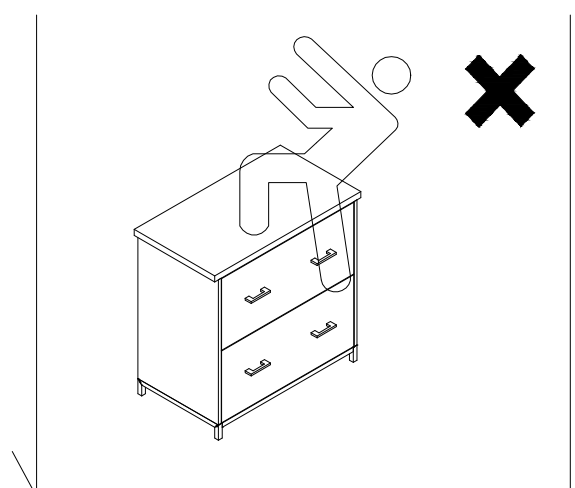
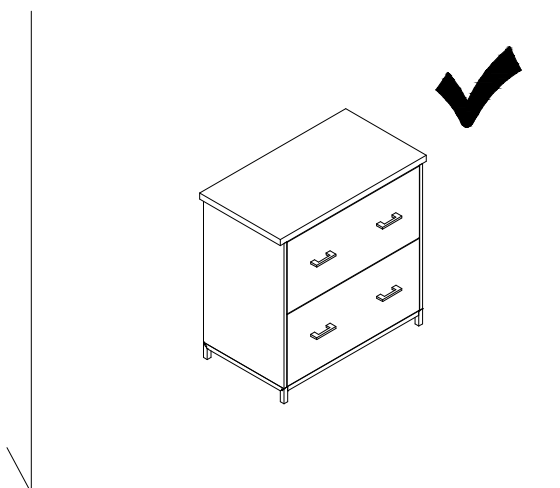

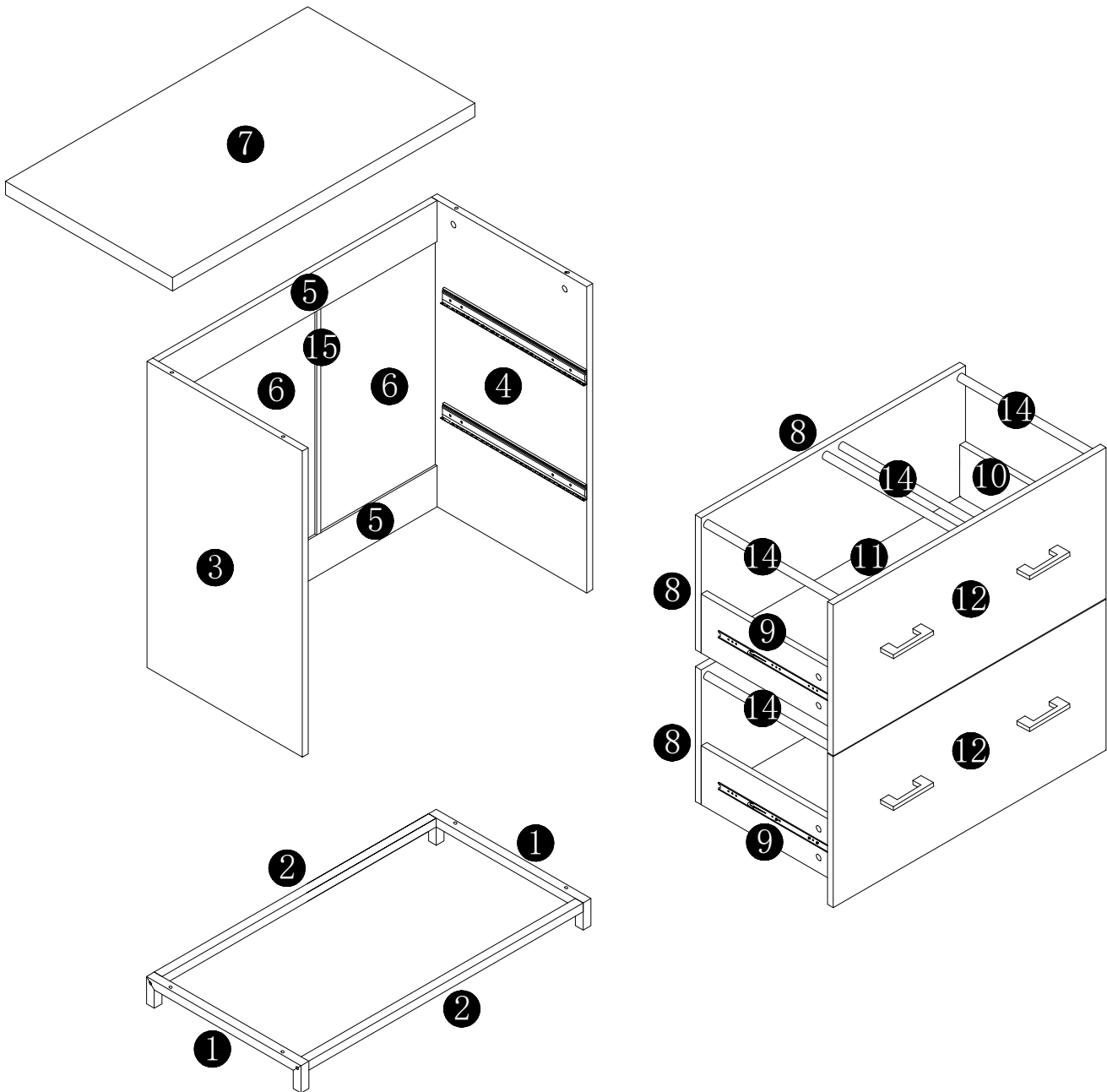







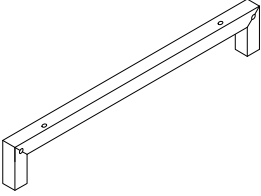
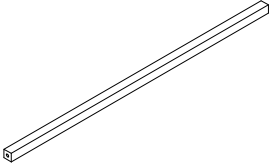
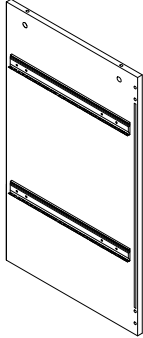
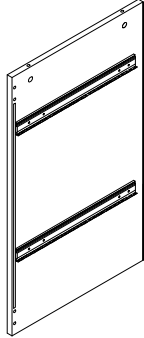
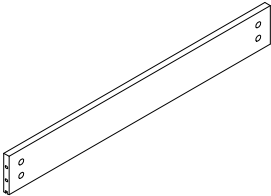

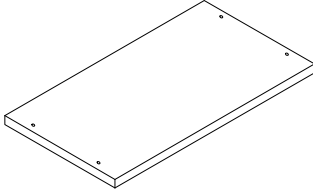
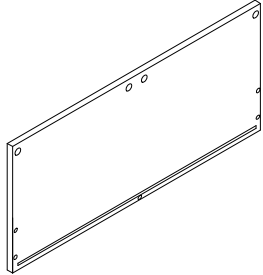
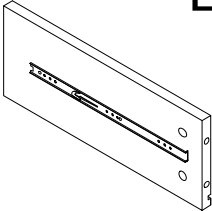
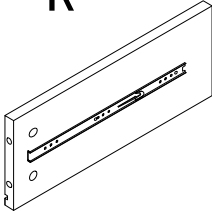
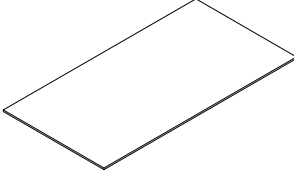
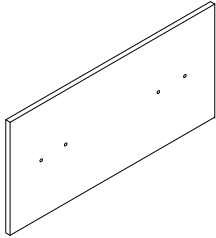
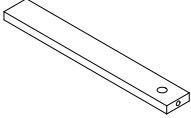
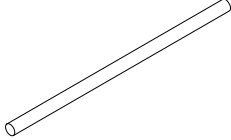
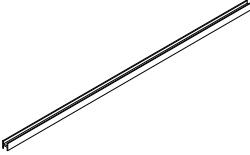



⚠ Caution

Make sure all parts are included. Most board parts are labeled or stamped on the raw edge. Contact us for a free replacement if you encounter any damaged or missing parts.

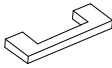
Hardware List

 <p>① 2pcs</p>	 <p>② 2pcs</p>	 <p>③ 1pc</p>	 <p>④ 1pc</p>
 <p>⑤ 2pcs</p>	 <p>⑥ 2pcs</p>	 <p>⑦ 1pc</p>	 <p>⑧ 2pcs</p>
<p>L</p>  <p>⑨ 2pcs</p>	<p>R</p>  <p>⑩ 2pcs</p>	 <p>⑪ 2pcs</p>	 <p>⑫ 2pcs</p>
 <p>⑬ 2pcs</p>	 <p>⑭ 8pcs</p>	 <p>⑮ 1pc</p>	

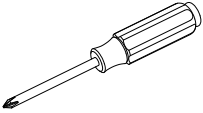
Hardware List

 <p>A 22pcs</p>	 <p>B 14pcs</p>	 <p>C 22pcs</p>
 <p>E 4pcs</p>	 <p>K 4pcs</p>	 <p>Q 4pcs</p>
 <p>S 8pcs</p>	 <p>U 4pcs</p>	 <p>Y 4pcs</p>
		

Installation of Cams and Pins

Screw the pin into the hole. To set the cams correctly, ensure that the arrow on the cam is opening to the hole of the pin it is locking. Lock the cam by turning the cam head with a screwdriver until it is tightened. Please do not use an electric screwdriver to assemble the unit.

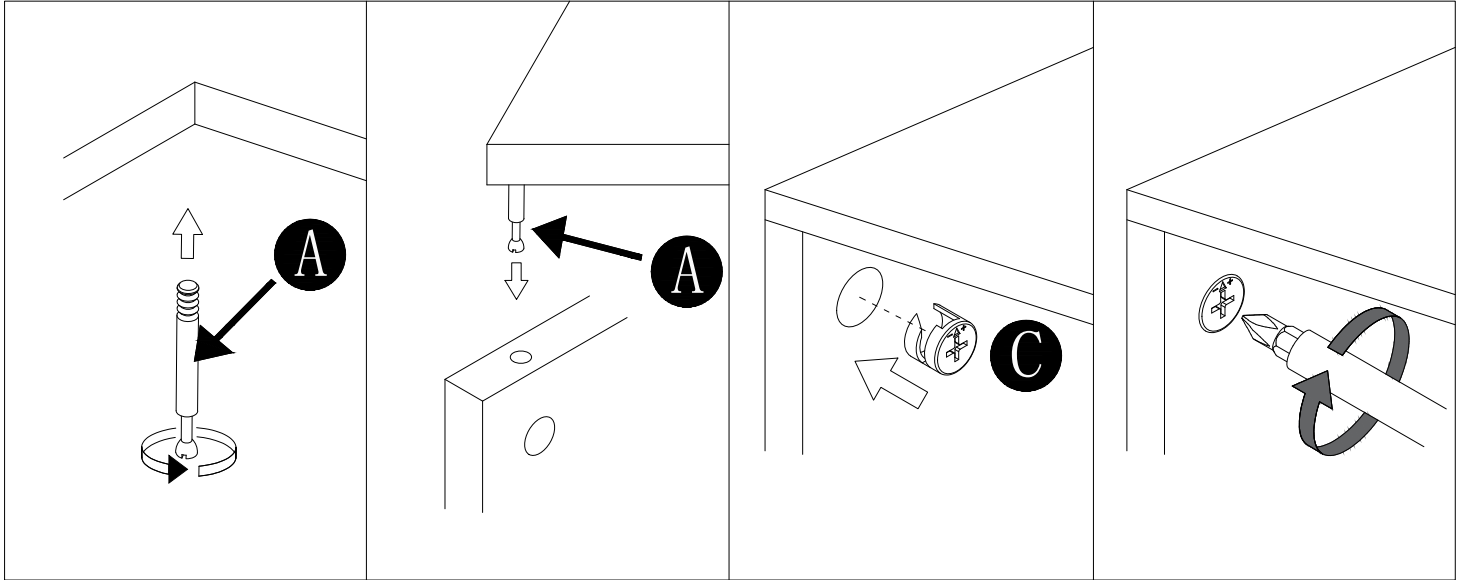

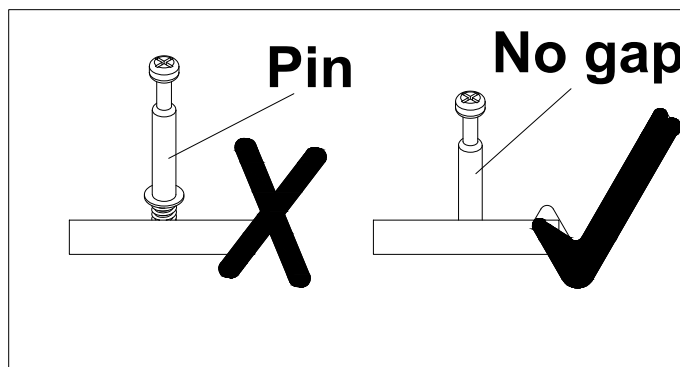

Read each step carefully before starting. It is very important that each step of instruction is performed in the correct order. If these steps are not followed in sequence, assembly difficulties will occur.



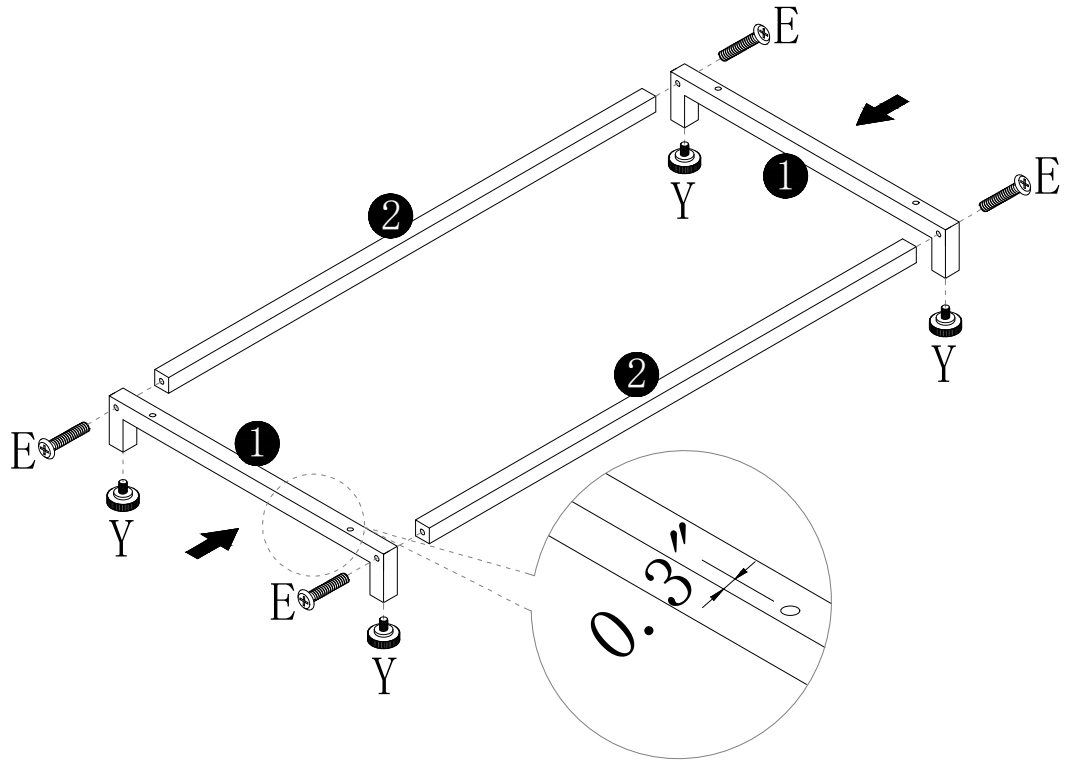

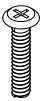
1

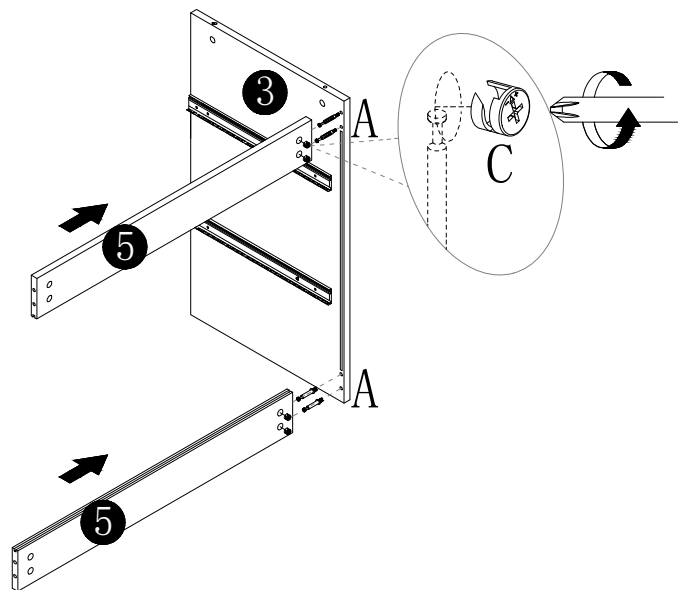

-  Ex4
-  Yx4

2



-  Ax4
-  Cx4

3

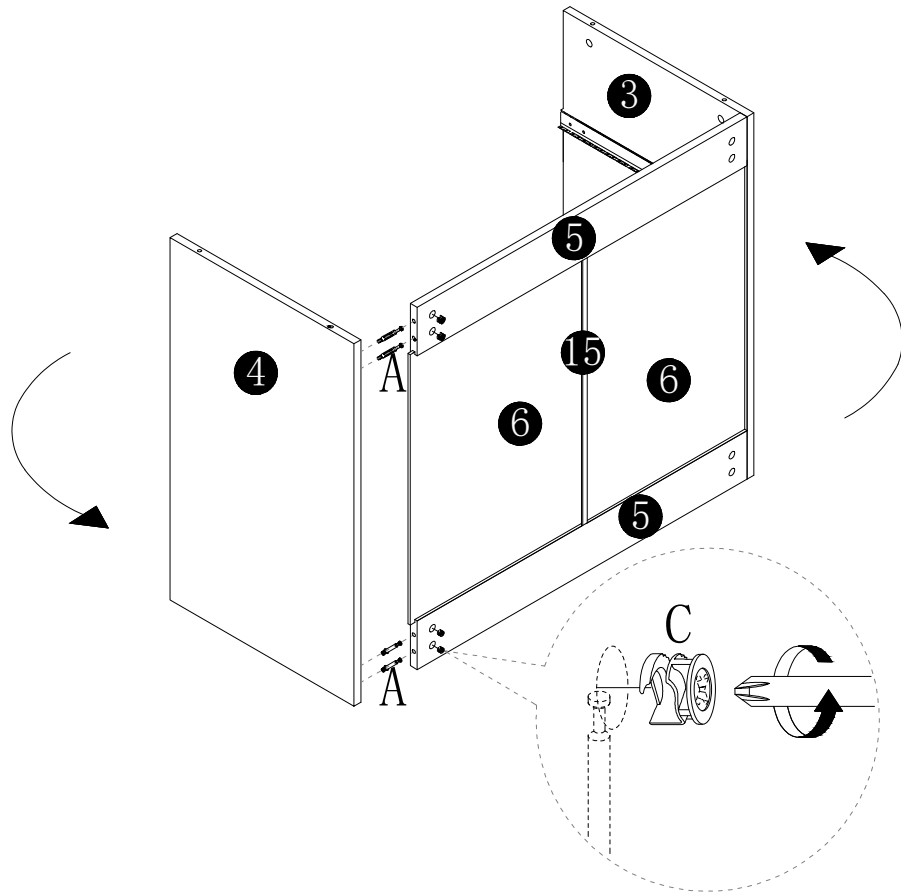

Ax4 Cx4

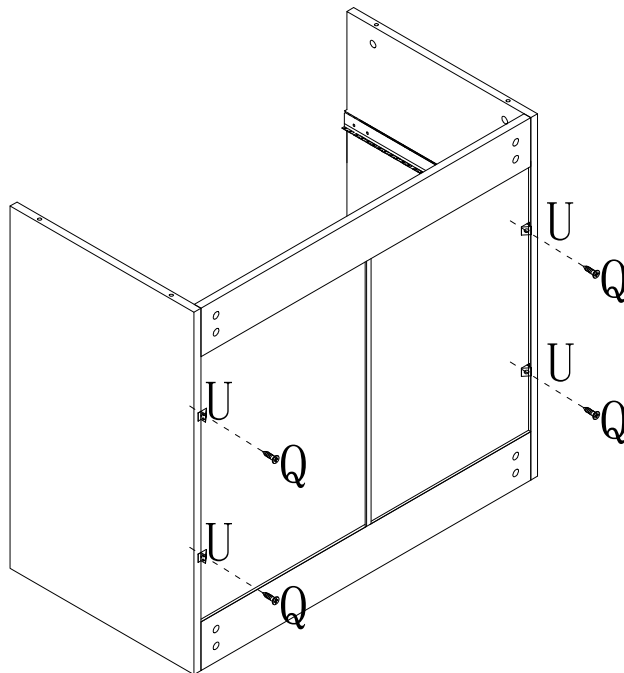

4

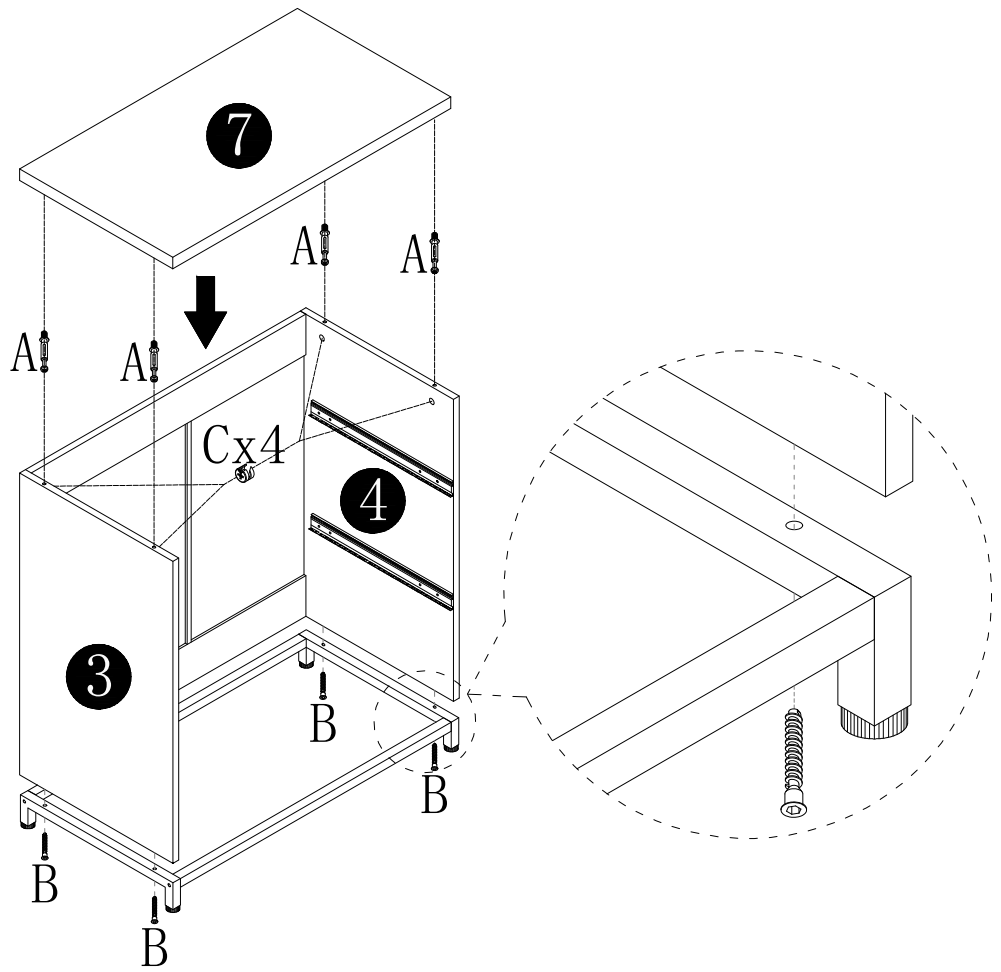

Ux4 Qx4

5



-  Bx4
-  Ax4
-  Cx4

6

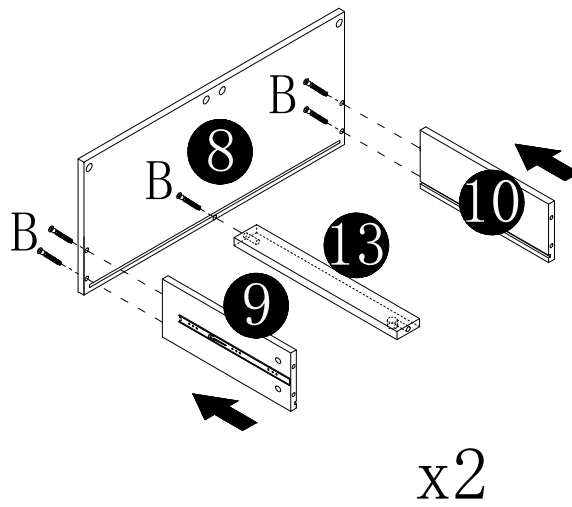

x2

-  Bx10

7

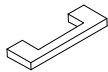
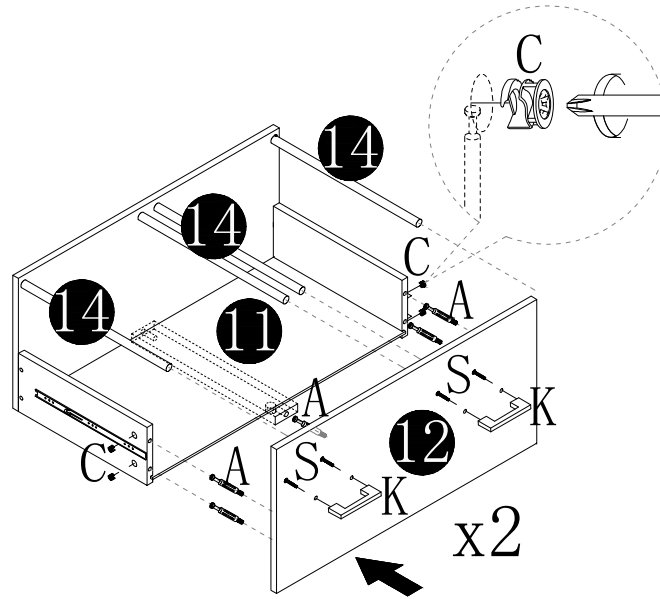

Ax10 Cx10 Kx4 Sx8

8

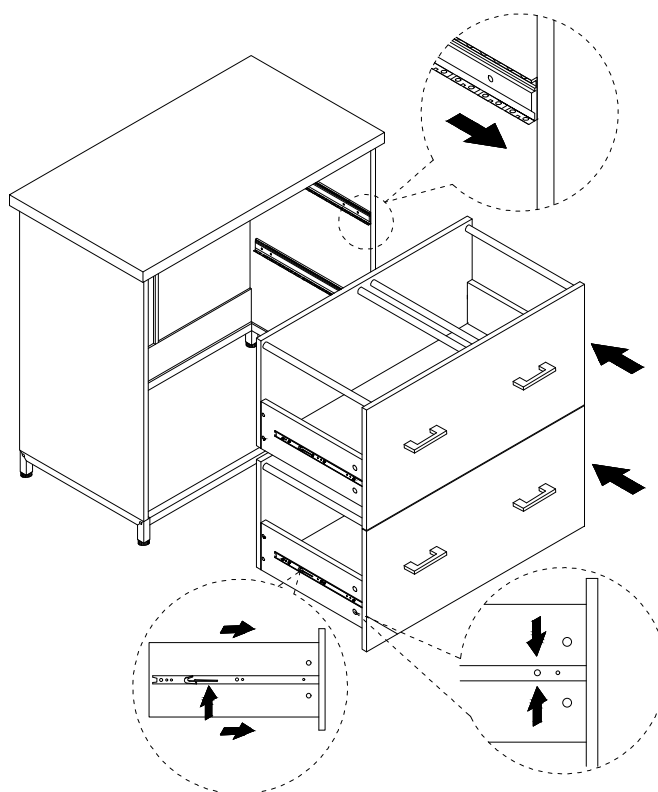



Thank you for your support!

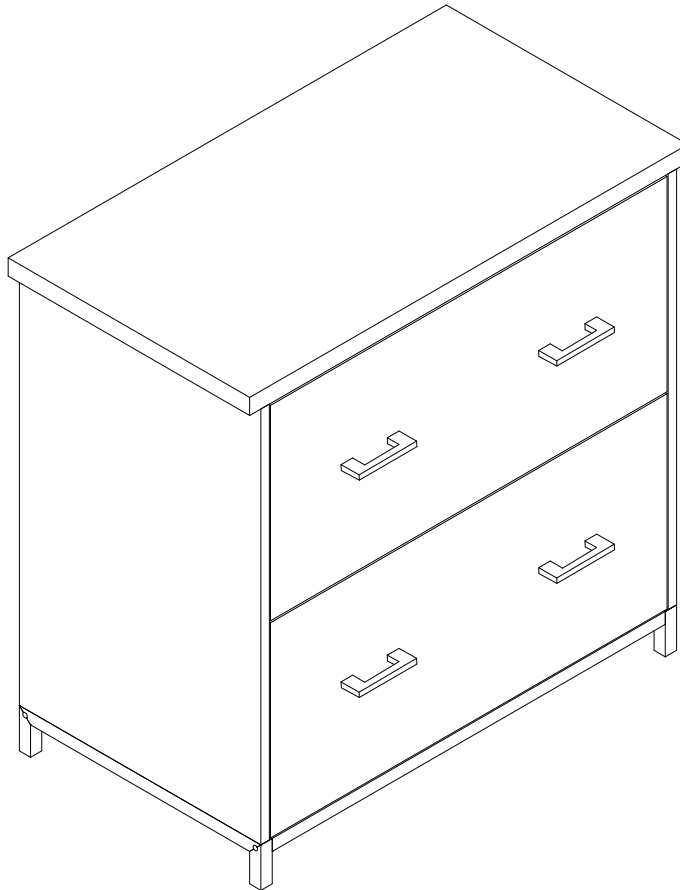

Contact our customer service team



support@tribesigns.com
www.tribesigns.com



1-424-220-6888
Contact us anytime except
12:00 AM to 8:00 AM EST.

Follow Tribesigns



Facebook



Instagram



Pinterest



Twitter



YouTube

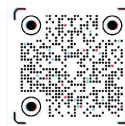

TikTok



WhatsApp