











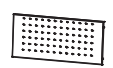



























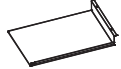





No.	#	QTY / CANT. / QTÉ	Description / Descripción / Description	Image / Imagen / Image
1	LJDB043B	1	Bottom shelf Estante inferior Etagere inferieure	
2	06-XZL-1-19-DY	1	Wheel axle Eje de las ruedas Axe de roue	
3	05-SLL-04	2	Wheel Rueda Roue	
4	LJQDB053B	2	Cart board Panel de carro Panneau du chariot	
5	LJ11TGLFD	1	Left front leg (down) Pata delantera izquierda (abajo) Jambe avant gauche (bas)	
6	LJ11TGLFU	1	Left front leg (up) Pata delantera izquierda (arriba) Jambe avant gauche (haut)	
7	LJ11TGRFD	1	Right front leg (down) Pata delantera derecha (abajo) Jambe avant droite (bas)	
8	LJ11TGRFU	1	Right front leg (up) Pata delantera derecha (arriba) Jambe avant droite (haut)	
9	LJ11TGLBD	1	Left back leg (down) Pata trasera izquierda (abajo) Jambe arrière gauche (bas)	
10	LJ12TGLBU	1	Left back leg (up) Pata trasera izquierda (arriba) Jambe arrière gauche (haut)	
11	LJ11TGRBD	1	Right back leg (down) Pata trasera derecha (abajo) Jambe arrière droite (bas)	
12	LJ11TGRBU	1	Right back leg (up) Pata trasera derecha (arriba) Jambe arrière droite (haut)	
13	05-JSL-39	2	Leg base Base de la pata Base de pied	
14	05-JSL-16	4	Leg connector Conector de pata Connecteur de pied	
15	LJ11TGLJP	4	Leg brace Sujeción de pata Attelle de pied	
16	ELJYP013B-DS1	1	Grease tray Bandeja de recogida de grasa Lêchefrite	
17	06-YBL-01-PT5	1	Grease cup Depósito de recogida de grasa Bac à graisse	

No.	#	QTY / CANT. / QTÉ	Description / Descripción / Description	Image / Imagen / Image
18	07-GGL-30	1	Grease cup bracket Soporte de taza para grasa Support de coupe à graisse	
19	06-XNL-5-17ABK -PDD1-PBK-RGC	3	Knob Perilla Bouton	
20	LT02HL	1	Side shelf (L) Bandeja lateral (I) Étagère latérale (G)	
21	LT02HR	1	Side shelf (R) Bandeja lateral (D) Étagère latérale (D)	
22		1	Main body Cuerpo principal Corps principal	
23	ES33BJB3B 04-SBS-28-345	1	Lid handle Manija de la tapa Poignée du couvercle	
24	LLFHB01	3	Flame tamer Regulador de llama Atténuateur de flamme	
25	LLCYKW02-TS1	2	Cooking grate Rejilla para asar Grille de cuisson	
26	LS40WDJDZ	1	Thermometer base Base del termómetro Base du thermomètre	
27	06-WDJ-6-04	1	Thermometer Termómetro Thermomètre	
28	03-WZJ-L-02-A -DD1	1	Warming rack beam Viga de la rejilla de calentamiento Poutre du support de réchauffage	
29	03-BWW-L-01 -3B-TC3	1	Warming rack Rejilla para calentar Grille de réchauffement	
30	06-XZL-4-01-DD1	1	LP cylinder barrier bar Barra de seguridad para la bombona de gas Barre de barrière de bouteille de gaz	
31	07-QPG-15-DD1	1	LP cylinder screw Perno de fijación de la bombona Vis de bouteille de gaz	
32	LJQPGDB01	1	Screw bushing Buje del perno de fijación de la bombona Douille de vis	
33	LJQPGRB01-DS1	1	Thermal baffle Deflector térmico Panneau isolant	
34	05-LGL-04-WH	2	Rim cover Cubierta del borde Couvre-jante	

No.	#	Image / Imagen / Image	No.	#	Image / Imagen / Image
A	M5x55	 ×16	F	Shoulder screw Tornillo de hombro Vis d'épaule	 ×8
B	Pad Arandela Tampon	 ×2	G	M6x30	 ×8
C	Split pin Pasador partido Goupille fendue	 ×3	H	M5x10	 ×16
D	M6x12	 ×6	I	Washer Arandela Rondelle	 ×1
E	Hook Gancho Crochet	 ×6	J	M4x8	 ×2

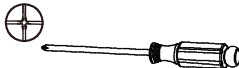
**TOOLS REQUIRED / HERRAMIENTAS REQUERIDAS / OUTILS REQUIS**

Phillips screwdriver Destornillador phillips Tournevis phillips	Wrench Llave Clé		
---	------------------------	--	---

Before beginning assembly, make sure all parts are present. If any parts are missing or damaged, do not attempt to assemble the products. Contact customer service for replacement parts via telephone or email.

- Tools needed (not included): Phillips screwdriver and wrench
- Approximate assembly time: 40 minutes
- Note: 1. The right and left sides of the grill are designed as if you are facing the front of the grill.  
2. Model shown for illustration purpose only, specific please in kind prevail.

Antes de comenzar el montaje, asegúrese de que todas las piezas estén presentes. Si falta alguna pieza o está dañada, no intente ensamblar los productos. Póngase en contacto con el servicio de atención al cliente para obtener piezas de repuesto por teléfono o correo electrónico.

- Herramienta necesaria (no incluido): Destornillador phillips y llave
- Tiempo aproximado de ensamblaje: 40 minutos
- Nota: 1. Los lados derecho e izquierdo de la parrilla están diseñados como si estuvieras frente a la parte delantera de la parrilla.  
2. El modelo que se muestra es sólo para fines ilustrativos, prevalecen los específicos en especie.

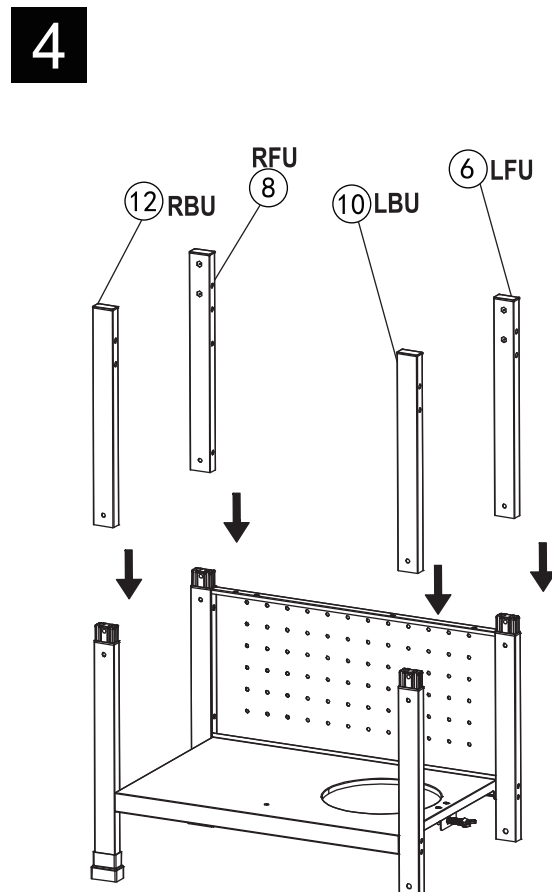
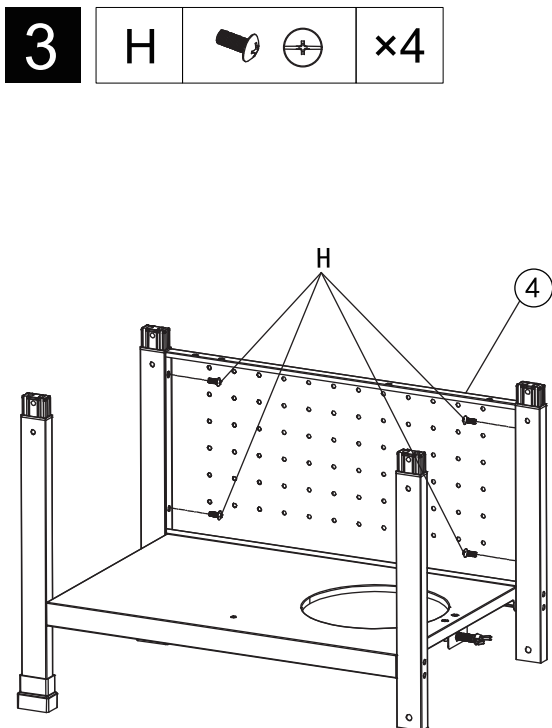
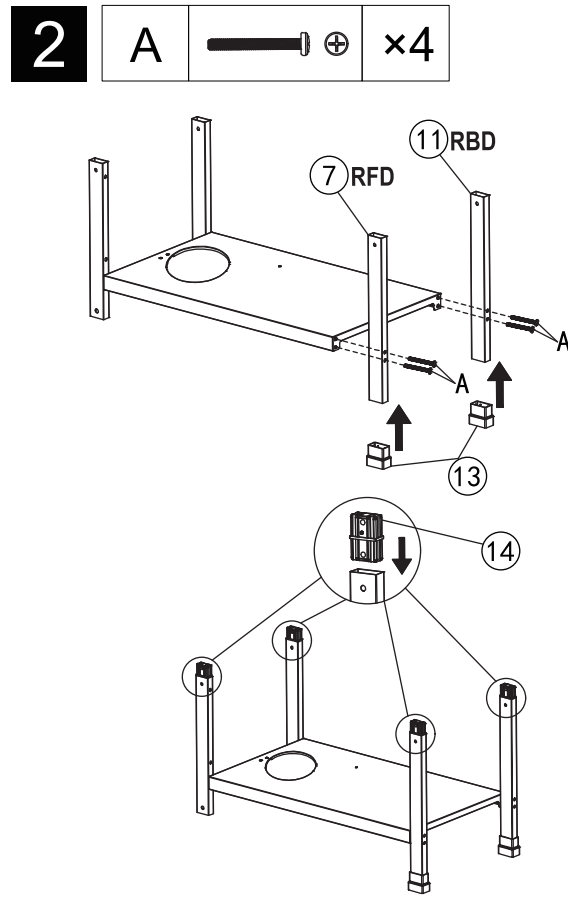
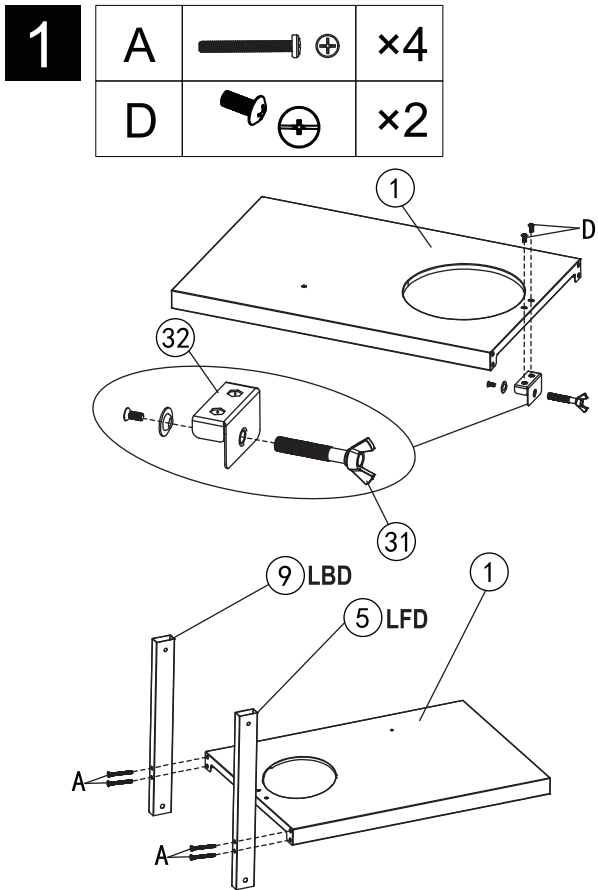

Avant de commencer l'assemblage, assurez-vous que toutes les pièces sont présentes. Si des pièces sont manquantes ou endommagées, n'essayez pas d'assembler les produits. Contactez le service de clientèle pour les pièces de rechange par téléphone ou par e-mail.

- Outils nécessaires (non inclus): Tournevis phillips et clé
- Temps nécessaire pour l'assemblage: 40 minutes
- Remarque: 1. les côtés droit et gauche du gril sont conçus comme si vous faisiez face à l'avant du gril.  
2. le modèle est présenté à des fins d'illustration uniquement, spécifiques en nature prévalent.

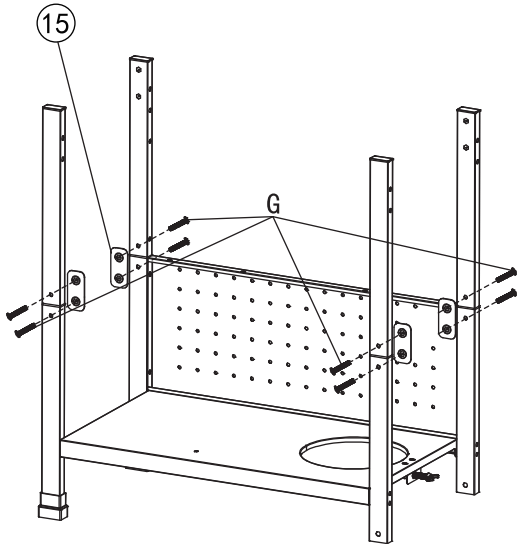

**5** G  ⊕ ×8



**6** B  ×2  
C  ×1

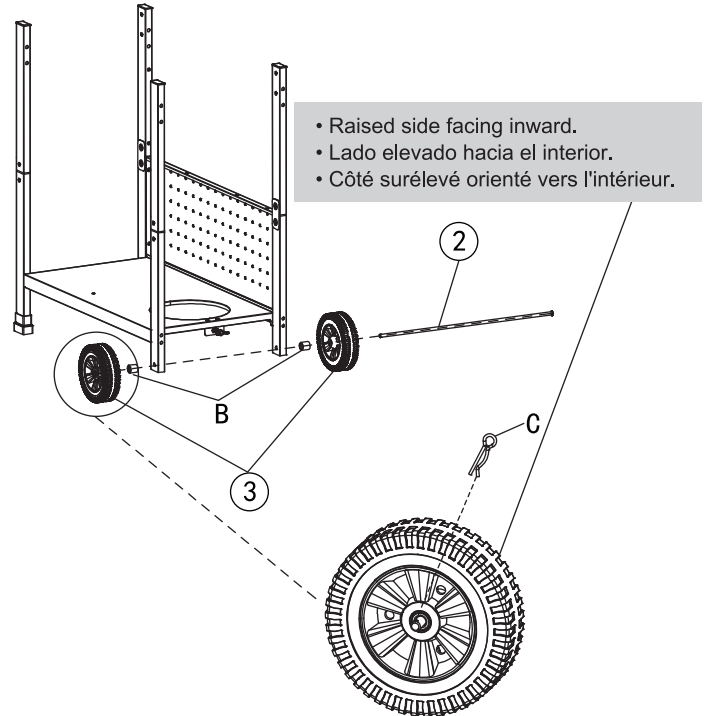



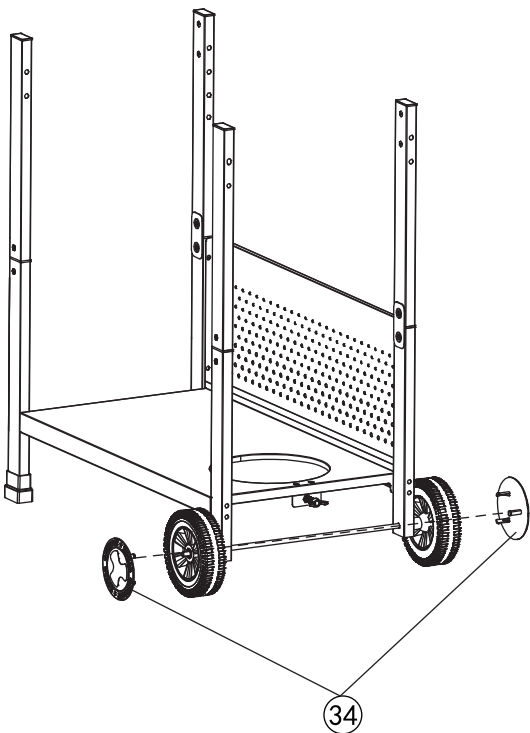

**7**

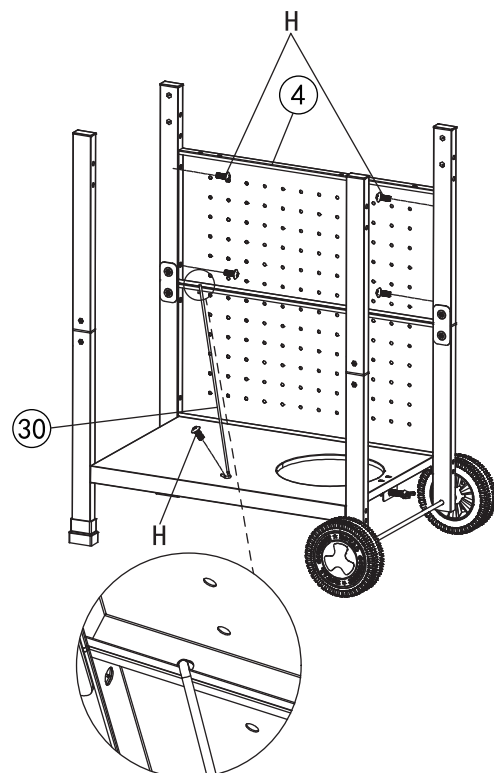

**8** H  ⊕ ×5



9	H			×1
	J			×2

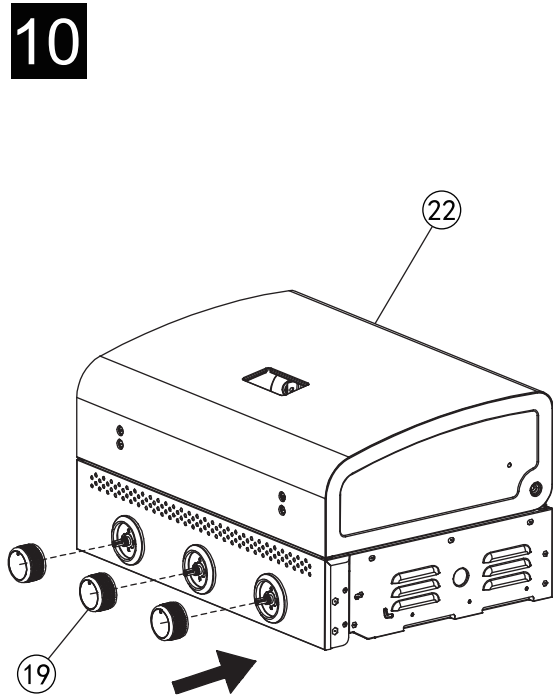
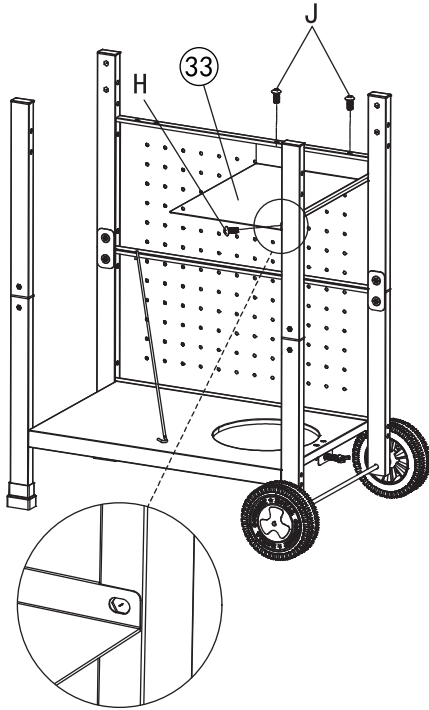

11	A		×8
----	---	---	----

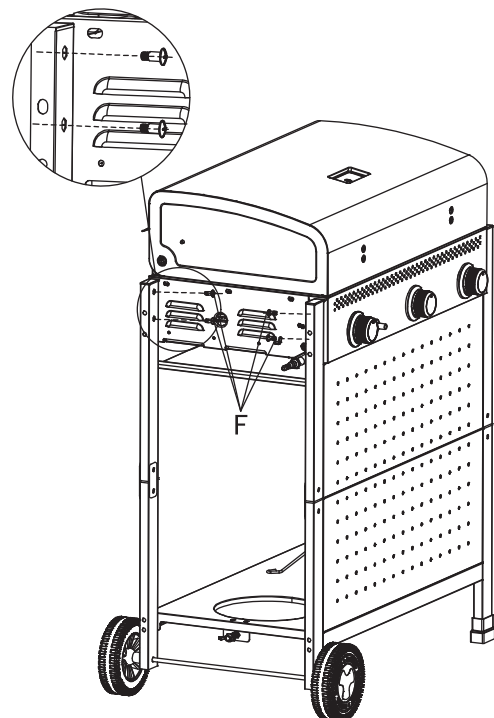
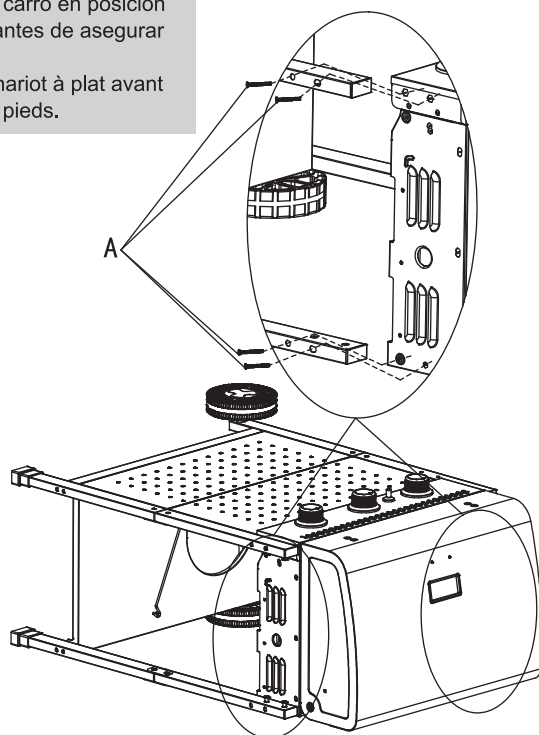

12	F		×4
----	---	---	----

- Lay down the cart before securing legs.
- Coloque el carro en posición horizontal antes de asegurar las patas.
- Posez le chariot à plat avant de fixer les pieds.

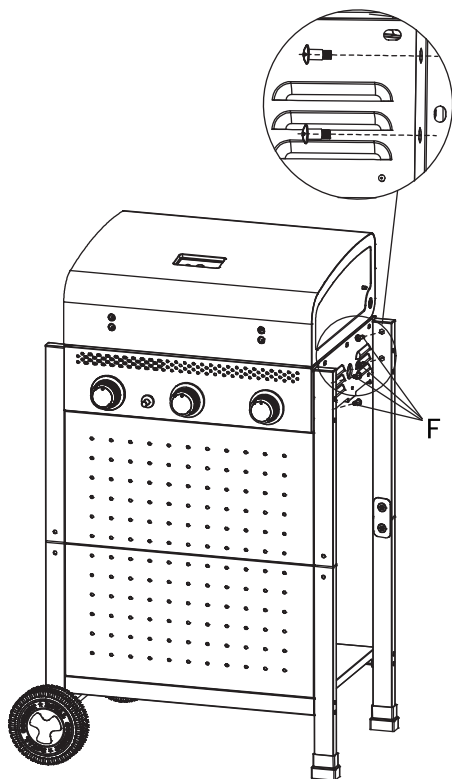

**13** F  ×4



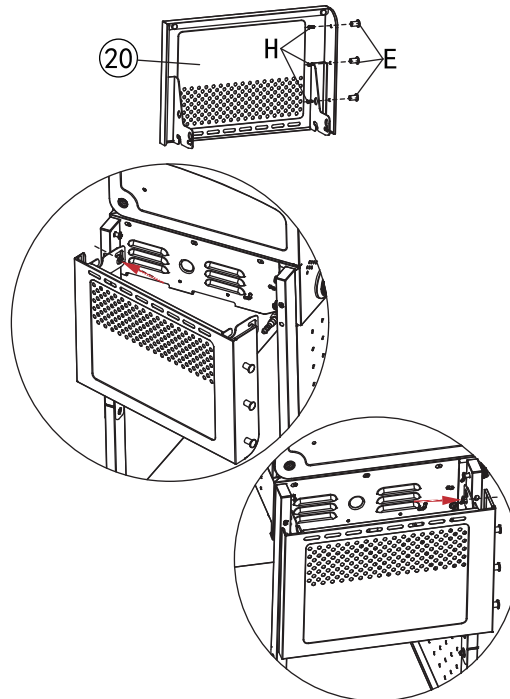

**14** E  ×3  
H   ×3

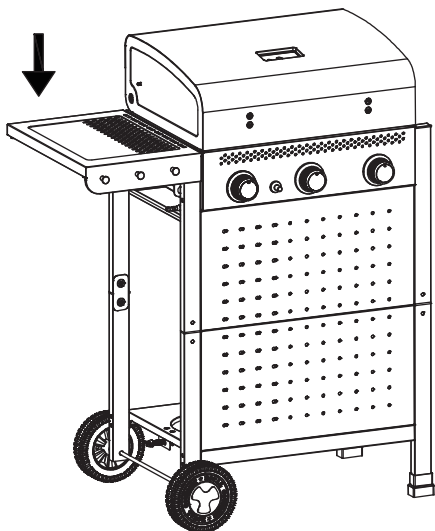
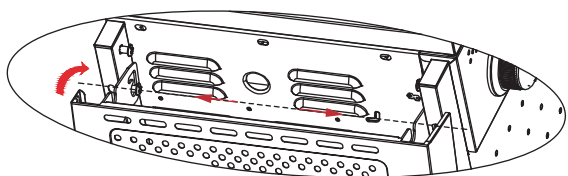

**15**



**16** E  ×3  
H   ×3

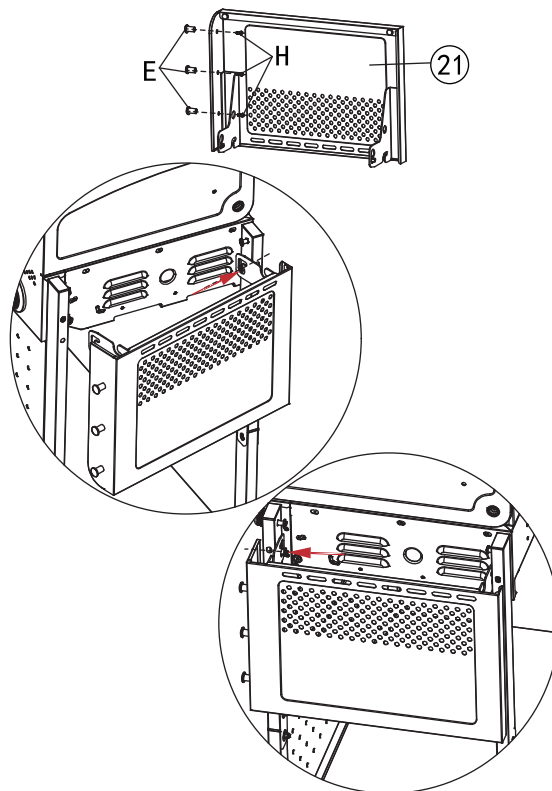

17

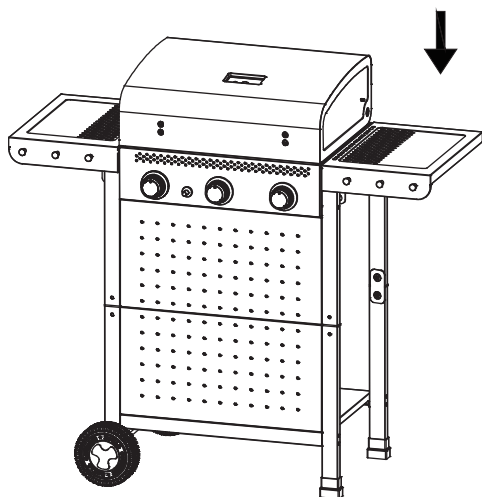
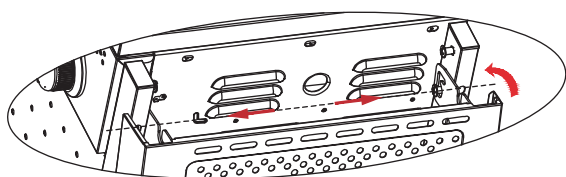

18

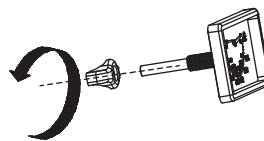
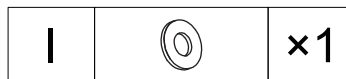

- Remove pre-installed nut in advance.
- Retire previamente la tuerca preinstalada.
- Retirez au préalable l'écrou préinstallé.

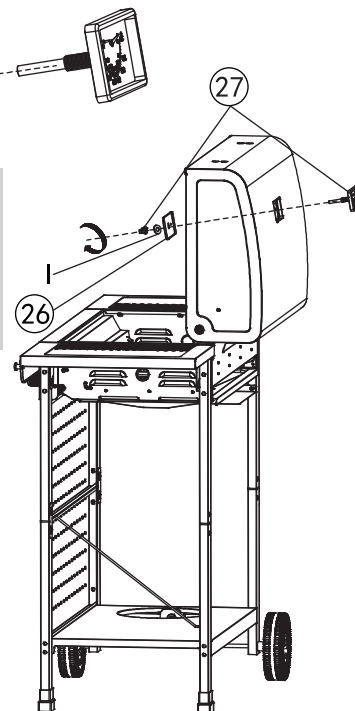

19

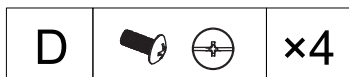

- Attach the handle with screws, then tighten through the top access hole.
- Fije el tirador con tornillos, luego apriete a través del orificio de acceso superior.
- Fixez la poignée avec des vis, puis serrez par le trou d'accès supérieur.

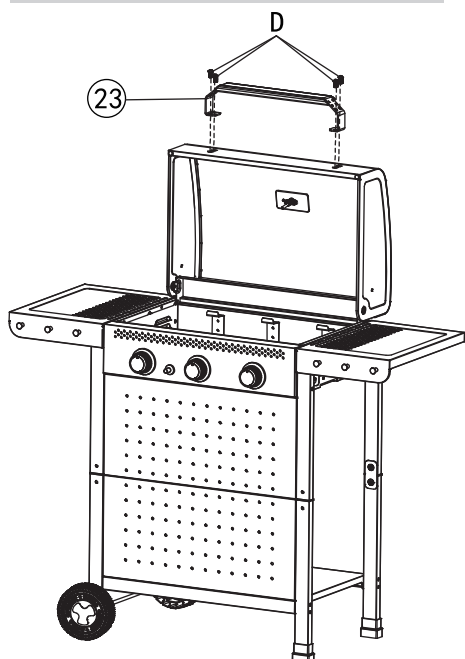

20

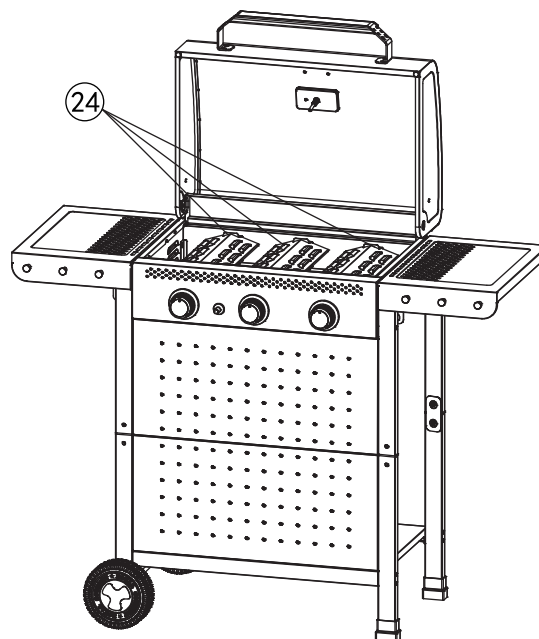
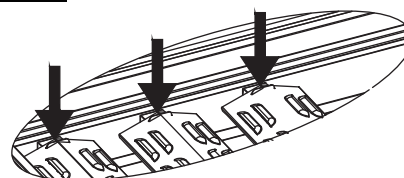

**21** C  ×2

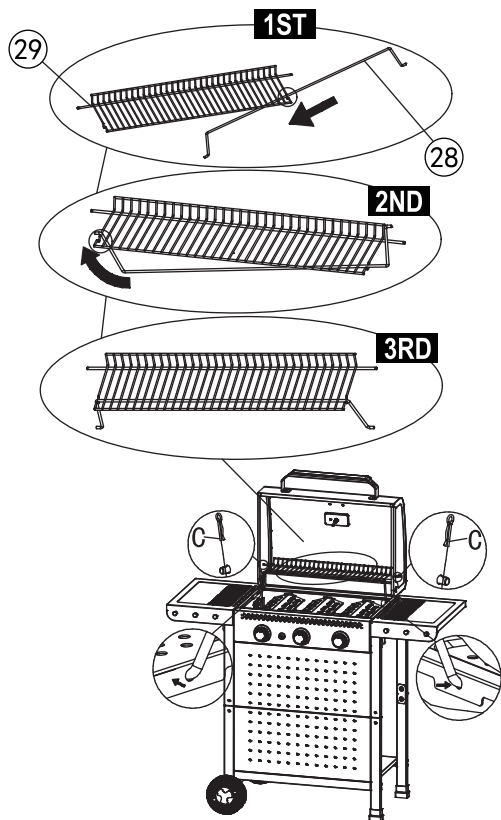

**22**

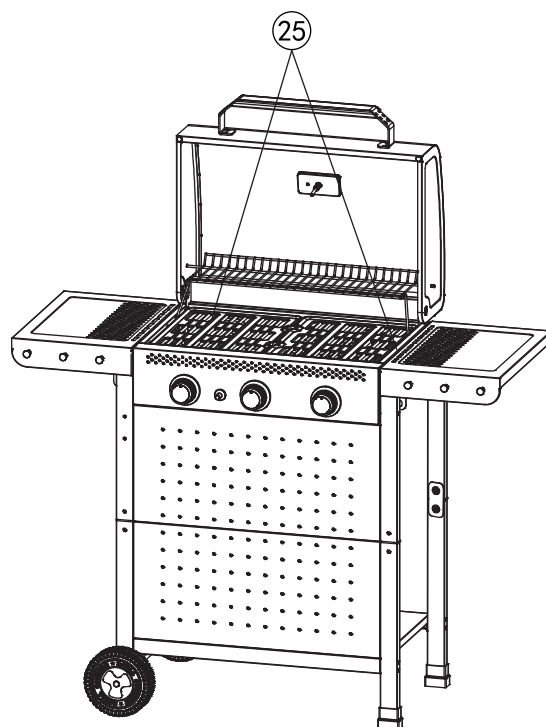

**23**

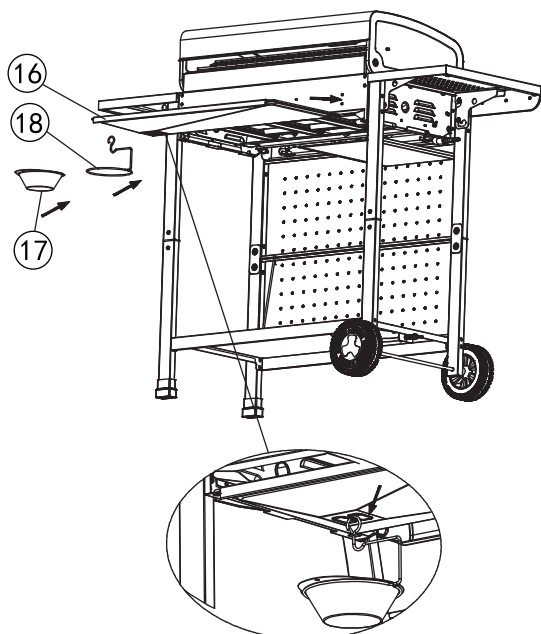

**24**

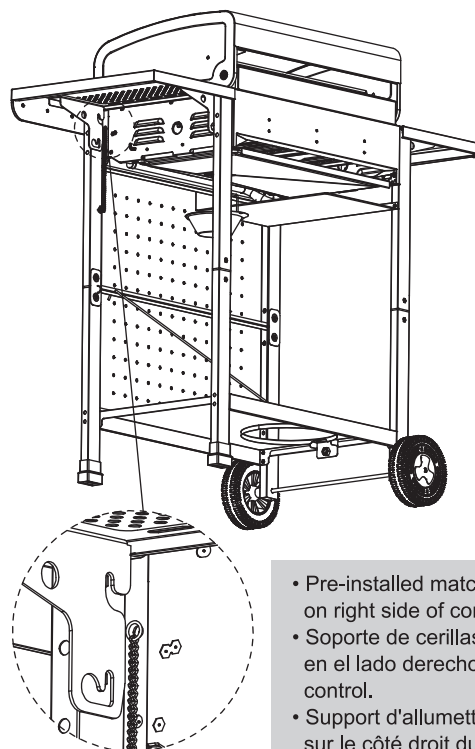

- Pre-installed match holder on right side of control panel.
- Soporte de cerillas preinstalado en el lado derecho del panel de control.
- Support d'allumettes préinstallé sur le côté droit du panneau de commande.

**Thank You  
For Choosing Us.**

**Any Problem!  
We Can Help!**

**Customer  
Service**

**1-800-618-6798**

**Monday to Friday (8:30 am - 5:00 pm EST)**

**[service@royalgourmetusa.com](mailto:service@royalgourmetusa.com)**