



MERCER VIII

66" x 36" Skirted Acrylic Combo Bath

Model Number
 3666MCSR_WH
 3666MCSL-WH
 RH & LH Drain White Combo
 3666MCSR-BI
 3666MCSL-BI
 RH & LH Drain Biscuit Combo

Features

- Color-matched jet trim and air controls
- 10 adjustable hydrotherapy jets
- 20+ high output lateral air injectors
- Constructed of high-gloss durable acrylic
- 3-Speed control for the 13.5 Amp pump
- 12 Amp variable speed blower
- Pre-leveled base for easy installation
- Pillow included
- Made in the USA



All dimensions are +/- 1/2" and subject to change without notice
Confirm specifications before installation

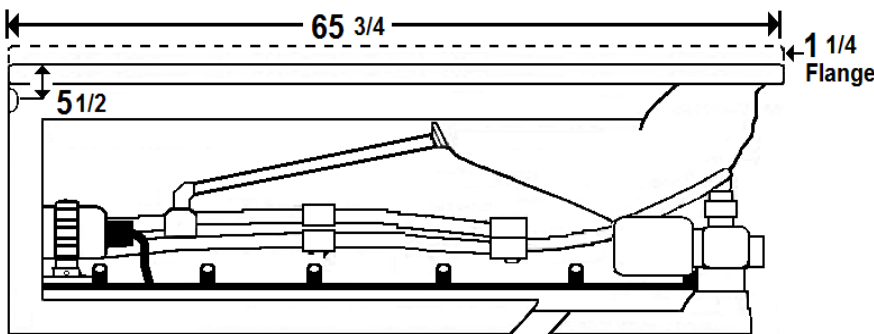
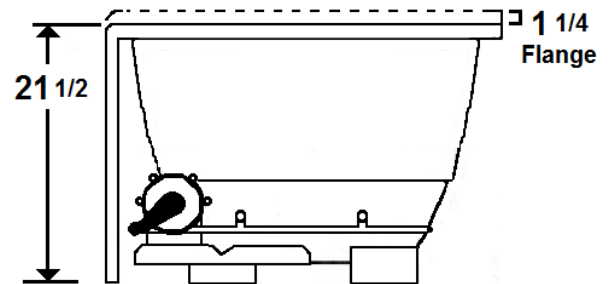
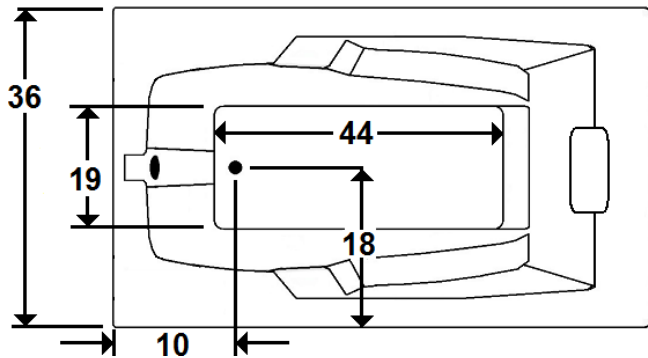

Standard (S) Pump Locations

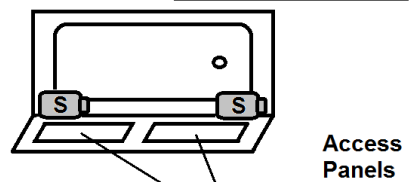
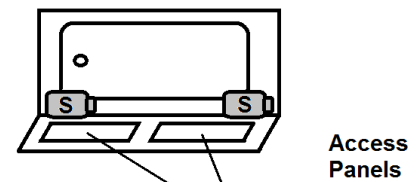

Technical Information

- Weight: 155 lbs.
- Water Depth to Overflow: 14"
- Water Operating Level: 47 gal.
- Water Capacity: 64 gal.
- Sump Dimension: 44" x 19"

Electrical Requirements.

- Standard Pump: 13.5 Amps
- Standard Blower: 12 Amps
- 2 Dedicated GFCI's required