













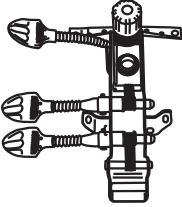

Estimated Assembly Time: 30mins

LB-8817

Assembly instructions

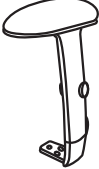
PARTS

① X 1 	A1.M6*20 X 2 
② X 1 	A2.M6*30 X 2 
③ X 1 	B.M6*40 X 6 
④ X 1 	C. X 6 
⑤ X 1 	D. X 1 
⑥ X 1(R) 	E. X 5 
⑦ X 1(L) 	F. X 1 
	G.M6*10mm X 1 

STEP 1

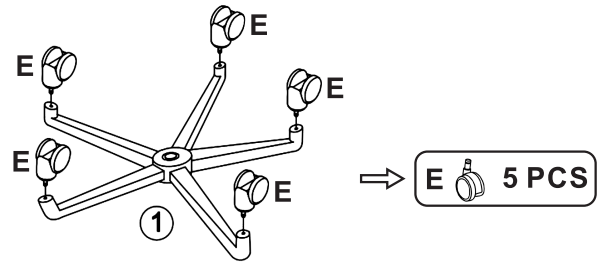

STEP 2

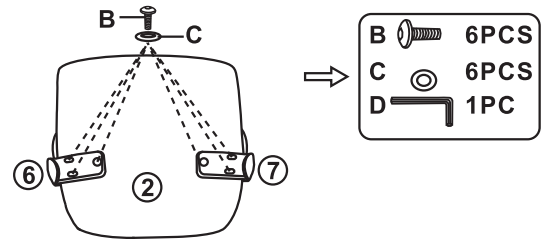

STEP 3

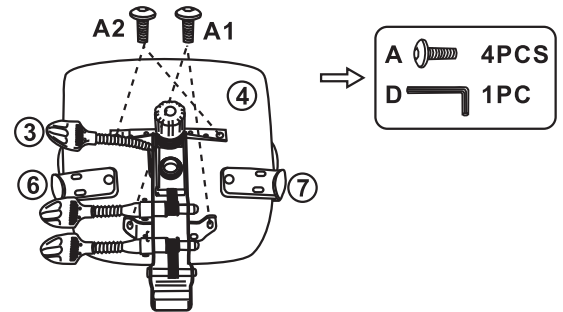

STEP 4

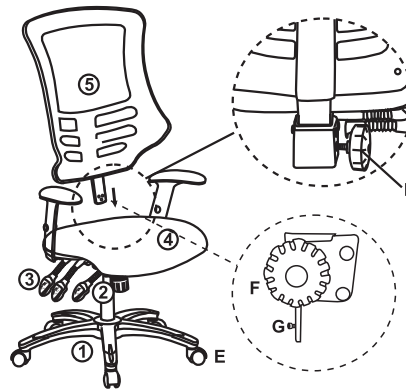

STEP 5

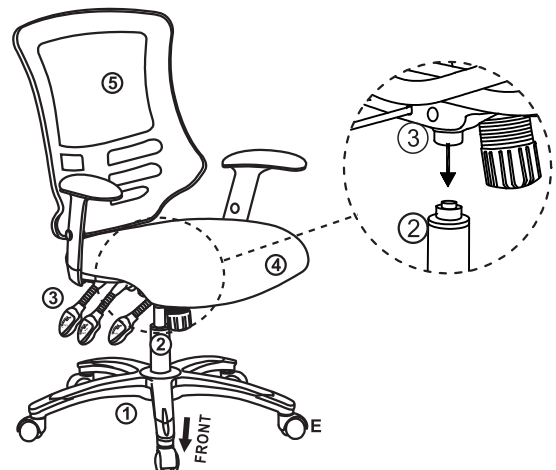

NOTICE:
EVERY 6 MONTHS, PLEASE MAKE SURE ALL BOLTS, SCREWS AND KNOBS ARE FULLY TIGHTENED TO ENSURE STABILITY.