

HO7305A0TX / HO7305B0TX

Huntleigh Turned-Leg Desk

Assembly Instructions



Southern  
ENTERPRISES

For assistance with assembly, contact:  
Southern Enterprises, Inc.  
Customer Service: 1-800-633-5096  
service@seidal.com  
www.seifurniturestore.com

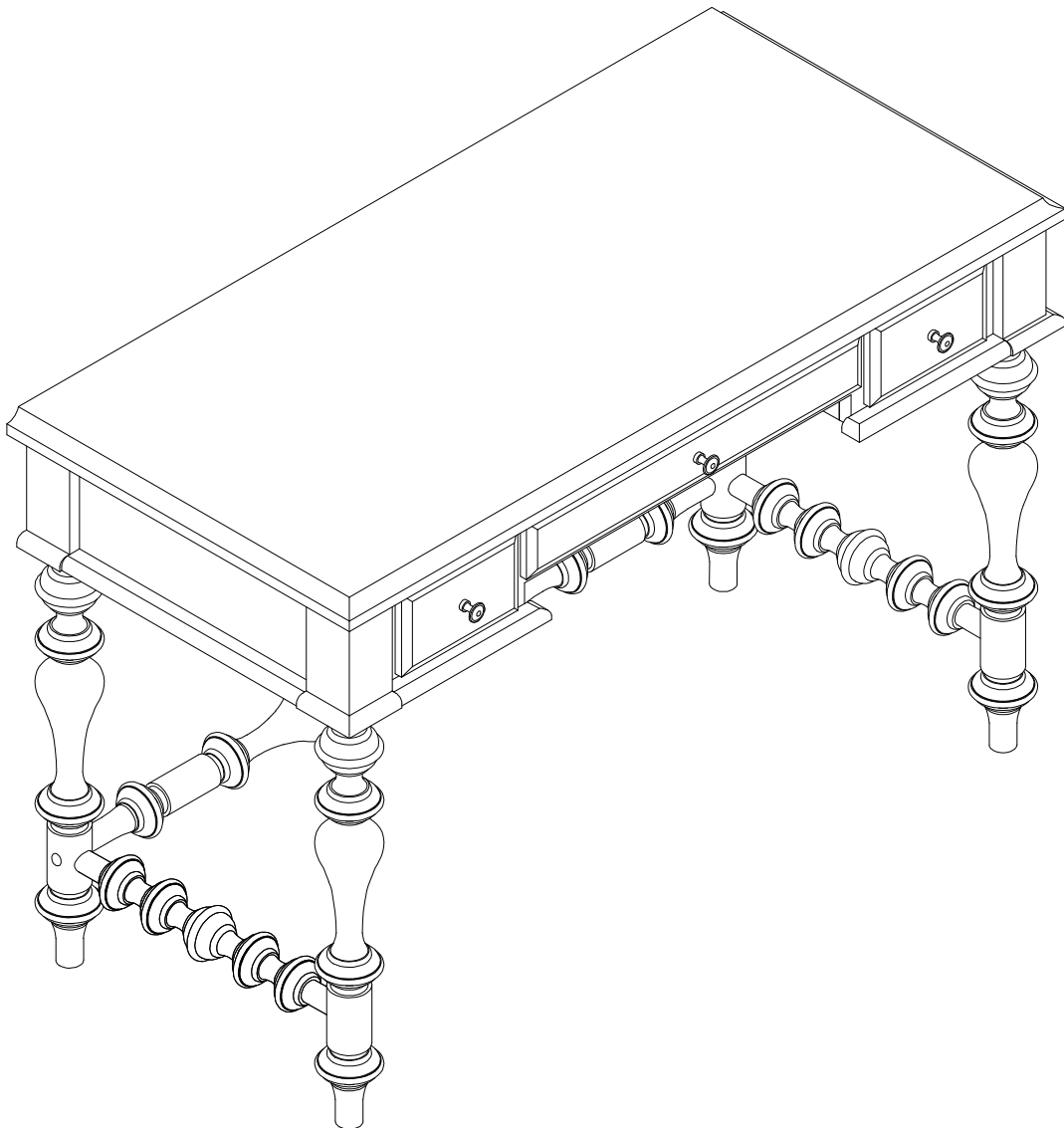

PO#:







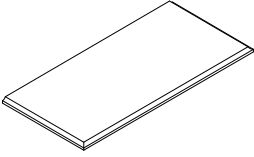
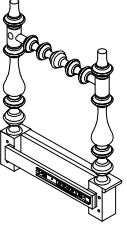
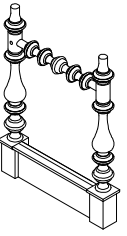
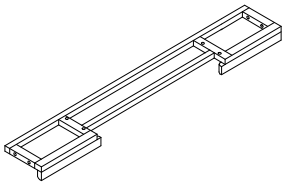
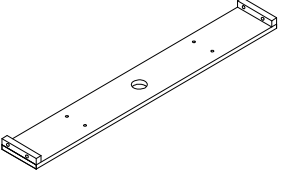

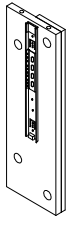
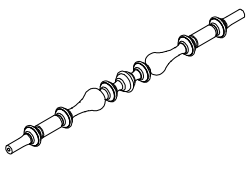
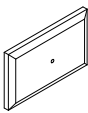
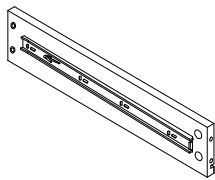
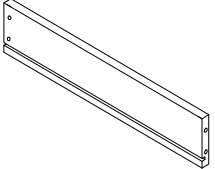
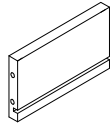

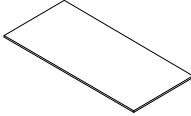
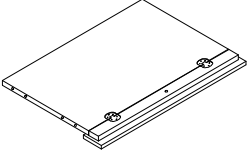
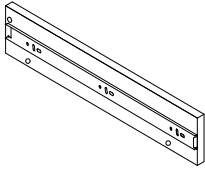
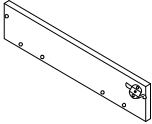
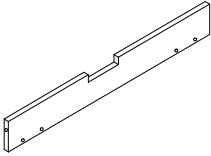





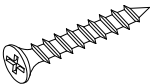
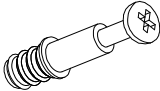

# Huntleigh Turned-Leg Desk

## Parts List

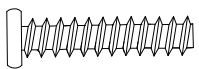
Please check packaging for all parts and hardware before discarding. Unpack and lay parts on clean, padded surface like carpet or a blanket. Check that you have all parts indicated. Call customer service if any hardware is missing. Before beginning assembly, carefully study the diagrams below and sort your hardware according to the pictures. Using the incorrect hardware will cause damage.

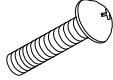
<p>1) Quantity of 1</p>  <p>Top Panel</p>	<p>2) Quantity of 1</p>  <p>Left Side Panel</p>	<p>3) Quantity of 1</p>  <p>Right Side Panel</p>
<p>4) Quantity of 1</p>  <p>Front Panel</p>	<p>5) Quantity of 1</p>  <p>Back Panel</p>	<p>6) Quantity of 1</p>  <p>Left Middle Panel</p>
<p>7) Quantity of 1</p>  <p>Right Middle Panel</p>	<p>8) Quantity of 1</p>  <p>Cross Panel</p>	<p>9) Quantity of 2</p>  <p>Small Drawer Front Panel</p>
<p>10) Quantity of 2</p>  <p>Left Drawer Side Panel</p>	<p>11) Quantity of 2</p>  <p>Right Drawer Side Panel</p>	<p>12) Quantity of 2</p>  <p>Drawer Back Panel</p>

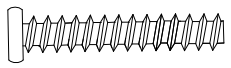
<p><b>13)</b> Quantity of 2</p>  <p>Small Drawer Bottom Panel</p>	<p><b>14)</b> Quantity of 1</p>  <p>Keyboard Drawer Bottom Panel</p>	<p><b>15)</b> Quantity of 1</p>  <p>Left Drawer Side Panel</p>
<p><b>16)</b> Quantity of 1</p>  <p>Right Drawer Side Panel</p>	<p><b>17)</b> Quantity of 1</p>  <p>Drawer Back Panel</p>	
<p><b>A)</b> Quantity of 15</p>  <p>Cam Bolts</p>	<p><b>B)</b> Quantity of 15</p>  <p>Cam Locks</p>	<p><b>C)</b> Quantity of 18</p>  <p>Wood Dowels Dia. 5/16"x1-1/4"</p>
<p><b>D)</b> Quantity of 7</p>  <p>Bolt Dia. 1/4x1-1/4" L</p>	<p><b>E)</b> Quantity of 4</p>  <p>Spring Washer Dia. 1/4"</p>	<p><b>F)</b> Quantity of 4</p>  <p>Flat washer Dia. 1/4" x 3/4"</p>
<p><b>G)</b> Quantity of 1</p>  <p>Allen Wrench</p>	<p><b>H)</b> Quantity of 12</p>  <p>Screw Dia. 5/32" x 1L</p>	<p><b>I)</b> Quantity of 8</p>  <p>Cam Bolts</p>

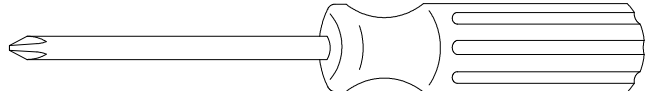
<p><b>J)</b> Quantity of 8</p>  <p>Cam Locks</p>	<p><b>K)</b> Quantity of 8</p>  <p>Bolt Dia. 1/4x1-1/2" L</p>	<p><b>L)</b> Quantity of 3</p>  <p>Knob</p>
<p><b>M)</b> Quantity of 3</p>  <p>Bolts Dia. 5/32" x 3/4" L</p>	<p><b>N)</b> Quantity of 4</p>  <p>Cotton Mat</p>	<p><b>O)</b> Quantity of 2</p>  <p>Wood Cap</p>
<p><b>P)</b> Quantity of 2</p>  <p>Bolt Dia. 1/4x1-3/4" L</p>	<p><b>Q)</b> Quantity of 8</p>  <p>Cotton Mat</p>	
<p><b>Care and Cleaning Instructions:</b>          Before using, wipe with a clean, dry cloth. Periodically apply furniture wax to renew the finish. Avoid rubbing or scratching the surface with rough or abrasive objects.</p>		<p>For replacement parts or questions, please call SEI customer Service at 1-800-633-5096.</p>
<p><b>Assembly Tool Required:</b>          No.2 Phillips Screwdriver          (Not Included)</p>		

# Huntleigh Turned-Leg Desk

## Assembly Instructions

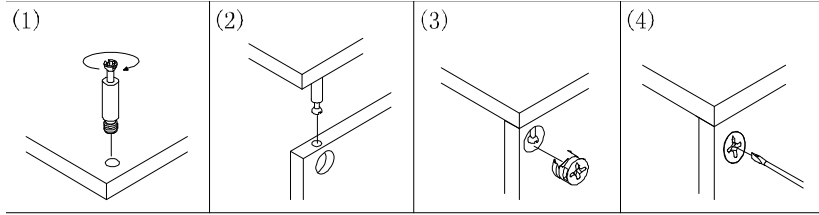

Please do not overtighten cam locks. Stop when they feel secure.

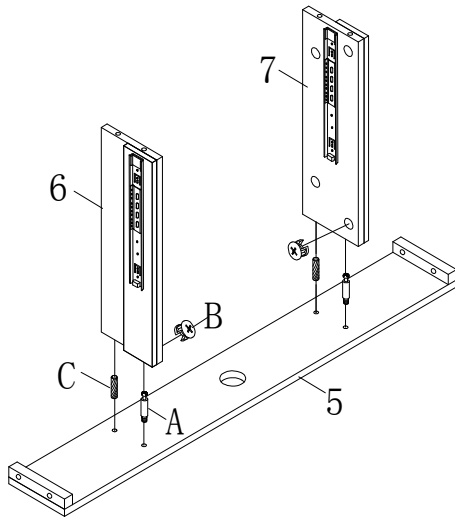

Figure 1

Insert Cam Locks **(B)** into corresponding holes on Middle Panel **(6/7)**.

Screw Cam Bolts **(A)** into threaded holes on Back Panel **(5)**.

Attach Back Panel **(5)** to Middle Panel **(6/7)** by inserting Cam Bolts **(A)** and Wood Dowels **(C)** into corresponding holes until all panels meet.

Tighten Cam Bolts **(A)** by rotating Cam Locks **(B)** clockwise using Phillips screwdriver (not included).

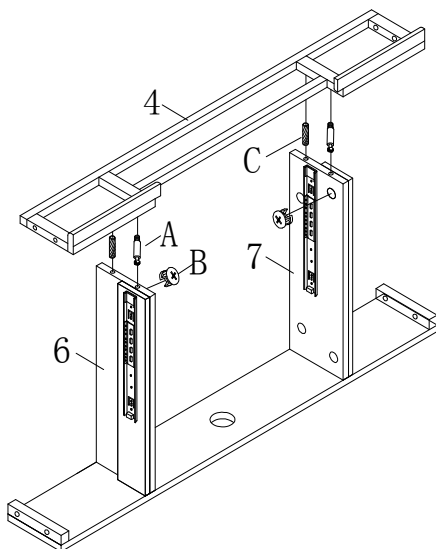

Figure 2

Insert Cam Locks **(B)** into corresponding holes on Middle Panel **(6/7)**.

Screw Cam Bolts **(A)** into threaded holes on Front Panel **(4)**.

Attach Front Panel **(4)** to Middle Panel **(6/7)** by inserting Cam Bolts **(A)** and Wood Dowels **(C)** into corresponding holes until all panels meet.

Tighten Cam Bolts **(A)** by rotating Cam Locks **(B)** clockwise using Phillips screwdriver (not included).

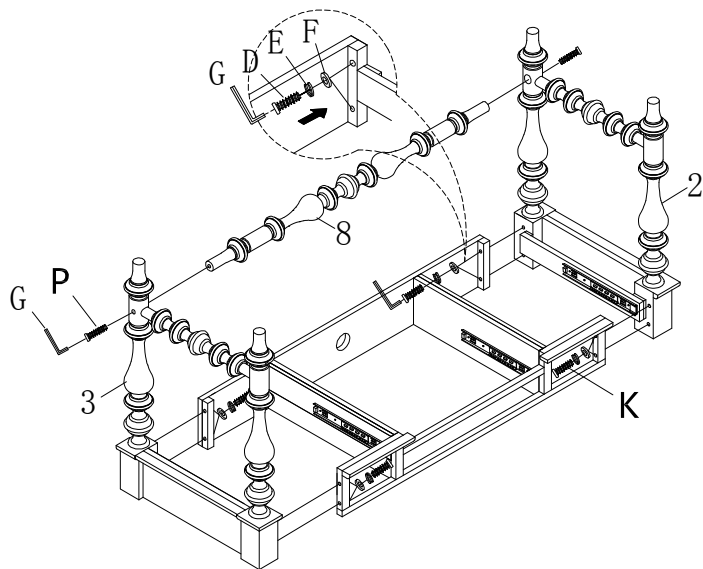

**Figure 3**

Attach the Left/Right Side Panel **(2/3)** to pre-assembled unit from Figure 2 with Bolts **(D/P/K)**, Spring Washers **(E)**, and Flat Washers **(F)**.

Tighten Bolt with Allen Wrench **(G)**.

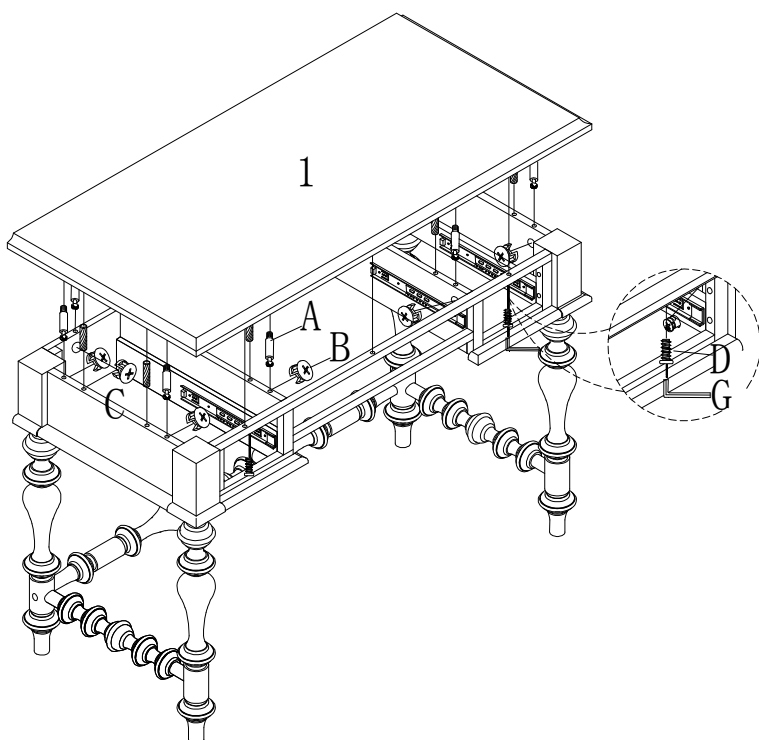

**Figure 4**

Insert Cam Locks **(B)** into corresponding holes on pre-assembled unit from Figure 3.

Screw Cam Bolts **(A)** into threaded holes on Top Panel **(4)**.

Attach Top Panel **(1)** to pre-assembled unit from Figure 3 by inserting Cam Bolts **(A)** and Wood Dowels **(C)** into corresponding holes until all panels meet.

Tighten Cam Bolts **(A)** by rotating Cam Locks **(B)** clockwise using Phillips screwdriver (not included).

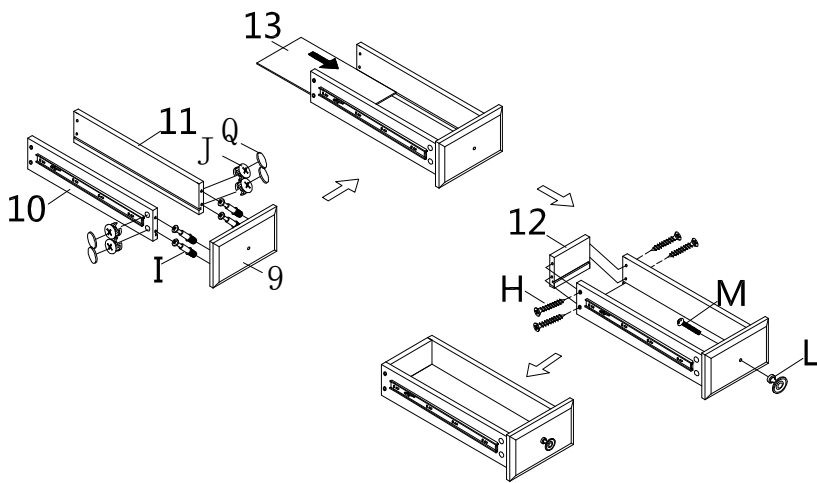

**Figure 5**

Attach Drawer Side Panels **(10/11)** to Drawer Front Panel **(9)** using Cam Bolts **(I)** and Cam Locks **(J)**.

Cover cam locks with adhesive pads **(Q)** as shown.

Insert Drawer Bottom Panel **(13)** into grooves of Drawer Side Panels **(10/11)**, and Drawer Back Panel **(12)**.

Attach Drawer Back Panel **(12)** to Drawer Side Panels **(10/11)** using Screws **(H)**.

Attach Knobs **(L)** to Drawer Front Panel **(9)** using Bolts **(M)** as shown.

Tighten Bolts **(M)** and Screws **(H)** with Phillips screwdriver (not included).

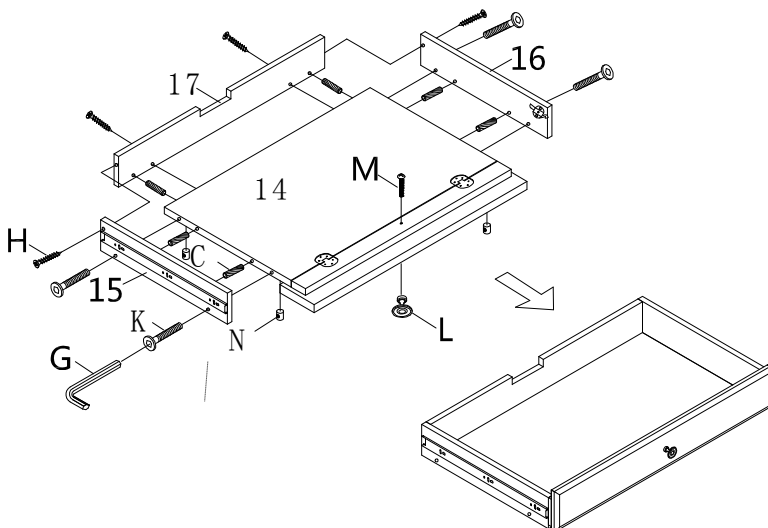

**Figure 6**

Connect Drawer Back Panel **(17)** to Drawer Bottom **(14)** using Wood Dowels **(C)**.

Connect Drawer Side Panels **(15/16)** to drawer using Wood Dowels **(C)**. Use Bolts **(K)**, Metal Nuts **(N)**, and Screws **(H)** to attach Drawer Side Panels **(15/16)**.

Tighten Bolts **(K)** and Screws **(H)** with Allen Wrench **(G)** and Phillips screwdriver (not included).

Attach Knob **(L)** to Drawer Front **(14)** using Bolts **(M)**.

Tighten bolts with Phillips screwdriver (not included).

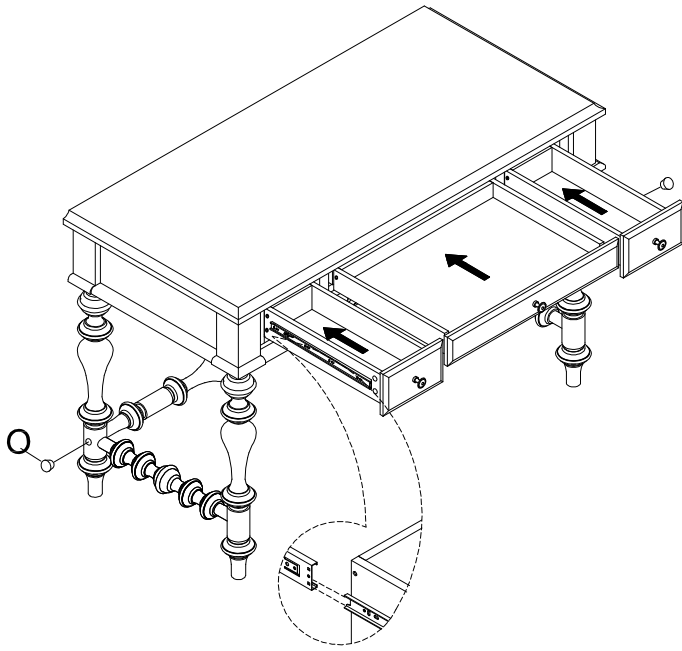

Figure 7

Insert drawers into pre-assembled unit.

Make sure all slides glide smoothly in and out.

Cover holes on legs with Wood Plugs (O).

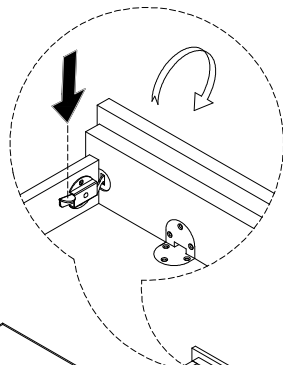
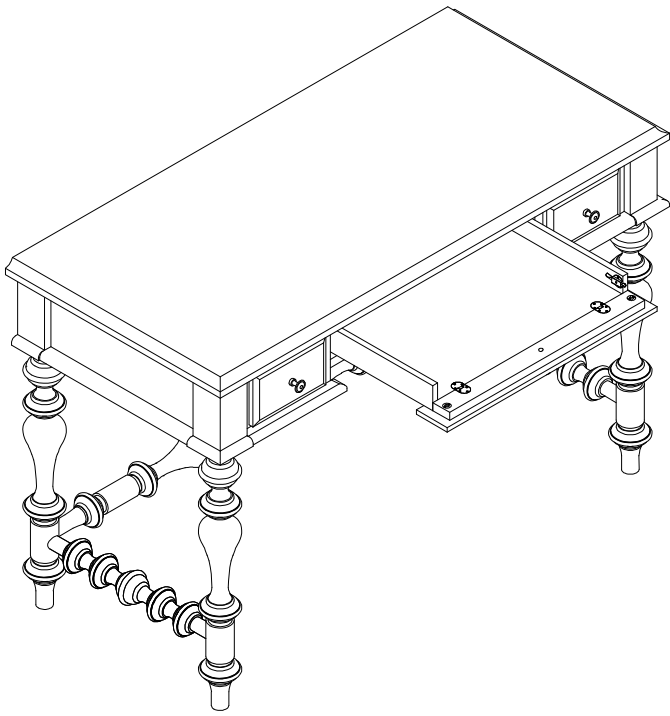

Figure 8

Note: There is a lever located on male slides for Keyboard Drawer. Hold levers up or down while pulling on drawer in order to detach male slide from female slide. This will flip the front of the drawer down for keyboard usage.



**Figure 9**

Now your Huntleigh Turned-Leg Desk is ready to us!

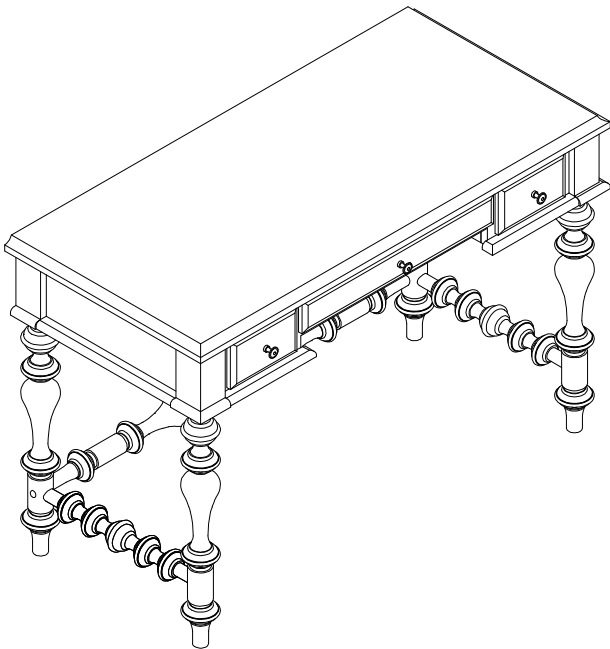

**Figure 10**

# Parts Replacement Form

## Customer Information

Name \_\_\_\_\_

Address \_\_\_\_\_

City/State/Zip Code \_\_\_\_\_

Phone Number \_\_\_\_\_

Please indicate where you purchased this item: Store/Website/Catalog

\_\_\_\_\_

Please indicate color/size/style number:

\_\_\_\_\_

Style No	Parts Letter	Parts Description	Quantity Needed
_____	_____	_____	_____
_____	_____	_____	_____
_____	_____	_____	_____

Please immediately examine this product carefully. Any request for missing parts or damage replacement must be received within 90 days of your receipt of the product. Replacement, if available, will be honored within this time frame. Parts will not be available for items arriving fully assembled. We do not recommend modifying product(s) and we are not responsible for any damages due to product modification(s). If damages or missing parts are not reported within 90 days of your receipt, we are under no obligation to provide parts or replacement merchandise.

For product issues, please contact Southern Enterprises at 800-633-5096 (toll-free) / 972-869-0111 (Dallas), Mon-Fri 9am – 4pm CST, or email us at [service@seidal.com](mailto:service@seidal.com). Please ask for customer service representative for issues involving damages or replacement parts. Please ask for technical assistance representative for any issues with product and assembly/construction.

Please contact the retailer that you purchased from for returns.



**Southern**  
ENTERPRISES

Customer Service: 1-800-633-5096  
[service@seidal.com](mailto:service@seidal.com)

Southern Enterprises, Inc.  
600 Freeport Parkway, Suite 200  
Coppell, Texas 75019