

TAR Select

2x2 Architectural LED Troffer Retrofit Kit

Product Description

The TAR Architectural LED Troffer Retrofit provides an economical, easy-to-install upgrade from linear fluorescent lighting to a long-lasting and energy-efficient LED solution. The contemporary center lens design delivers a soft natural glow with even illumination and minimized glare, making it an attractive general-purpose ambient lighting solution. The TAR also features a pre-mounted driver with a high-efficiency, maintenance-free LED chamber. Whether in a school, hospital, airport, office or convenience store, NICOR LED troffers bring a stylish and economical lighting solution to all commercial, educational, medical, and retail applications. The CCT Selectable design allows for easy adjustment to 3500K, 4000K, or 5000K.

Construction

- Durable steel construction with powder coat finish
- High efficiency, maintenance-free LED chamber
- Smooth formed sides for safe handling

Optical System

- Precision engineered polycarbonate diffuser
- No visible diodes, hot-spots, or shadows providing high uniformity, and reduced glare

Electrical

- Long-life LED system coupled with electrical driver to deliver optimal performance with 125+ lumens per watt depending on CCT
- Driver delivers full-range dimming from 0 - 10VDC
- Operating temperature rating of -4°F to 104°F (-20°C to 40°C)
- Input voltage of 120-277VAC

Mounting and installation

- Unique four rail system minimizes gaps, creating a more seamless look
- Quick and easy single person installation
- Features an integral driver for easy installation
- Seismic wire provided for safe installation and operation
- Suitable for use in IC rated troffer

Finish

- Matte white powder coat finish

Warranty

- 5-year limited system warranty standard
- Warranty does not cover product failure due to an overvoltage event (power surge.)
- TM-21 Projected L70(9k) life >50,000 hours
- LM-79, LM-80 testing performed in accordance with IESNA standards.

Project

Catalog

Type

Date

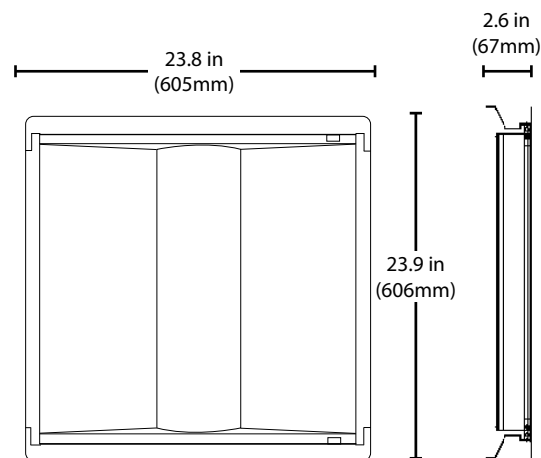

Photometric Data

TAR22 3500K, 30W

Input Voltage (VAC)	120-277
System Level Power (W)	30.60
Delivered Lumens (Lm)	3915
System Efficacy (Lm/W)	127.9
Correlated Color Temp (K)	3476
Color Rendering Index (CRI)	82
Beam Angle	126°
Spacing Criteria	1.25

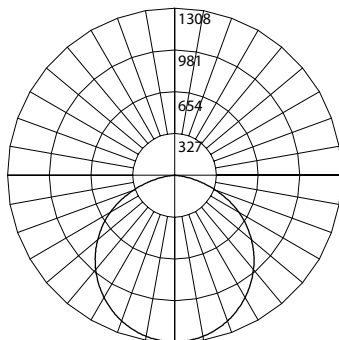

Intensity Summary (Candle Power)

Angle	Mean CP
0	1306
10	1275
20	1195
30	1072
40	915
50	732
60	539
70	350
80	172
90	2

Cone of Light Tabulation

Mounted height (Feet)	Footcandles Beam Center	Diameter (Feet)
8	20.4	31.4
10	13.1	39.3
12	9.1	47.1
14	6.7	55.0

Zonal Lumen Summary

Zone	Lumens	% of Luminaire
0-30	1007	25.7%
0-40	1649	42.1%
0-60	2940	75.1%
0-90	3915	100%
90-180	0	0%
0-180	3915	100%

Fixture tested per LM-79-08. Photometric data is of the performance of a representative fixture. Results may vary in the field.

Performance Data

Nominal CCT(K)	Power (W)	Light Output (lm)	Lumens/Watt
3500	30.6	3915	127.9
	25.3	3350	132.7
	20.1	2707	134.7
4000	29.7	4158	140.0
	25.3	3694	146.0
	20.1	3030	150.8
5000	30.7	3944	128.4
	25.3	3383	133.7
	20.1	2735	136.1

Recommended Dimmers*

Lutron NTSTV-DV-WH
Lutron DVSTV
Cooper SF10P
Legrand RH4FBL3PW

*Not a complete list. Check compatibility before installation.

Ordering Information

Example: TAR22U

Series	CCTs	Version	Size	Voltage
TAR	S (Selectable: 3500, 4000, 5000K)	1 (1.0)	22 (2' x 2')	U(120-277V)

Specifications and dimensions subject to change without notice.

This device complies with part 15 of the FCC Rules. Operation is subject to the following two conditions: (1) This device may not cause harmful interference, and (2) this device must accept any interference received, including interference that may cause undesired operation.

NOTE: This equipment has been tested and found to comply with the limits for a Class A digital device, pursuant to part 15 of the FCC Rules. These limits are designed to provide reasonable protection against harmful interference when the equipment is operated in a commercial environment. This equipment generates, uses, and can radiate radio frequency energy and, if not installed and used in accordance with the instruction manual, may cause harmful interference to radio communications. Operation of this equipment in a residential area is likely to cause harmful interference in which case the user will be required to correct the interference at his own expense.