

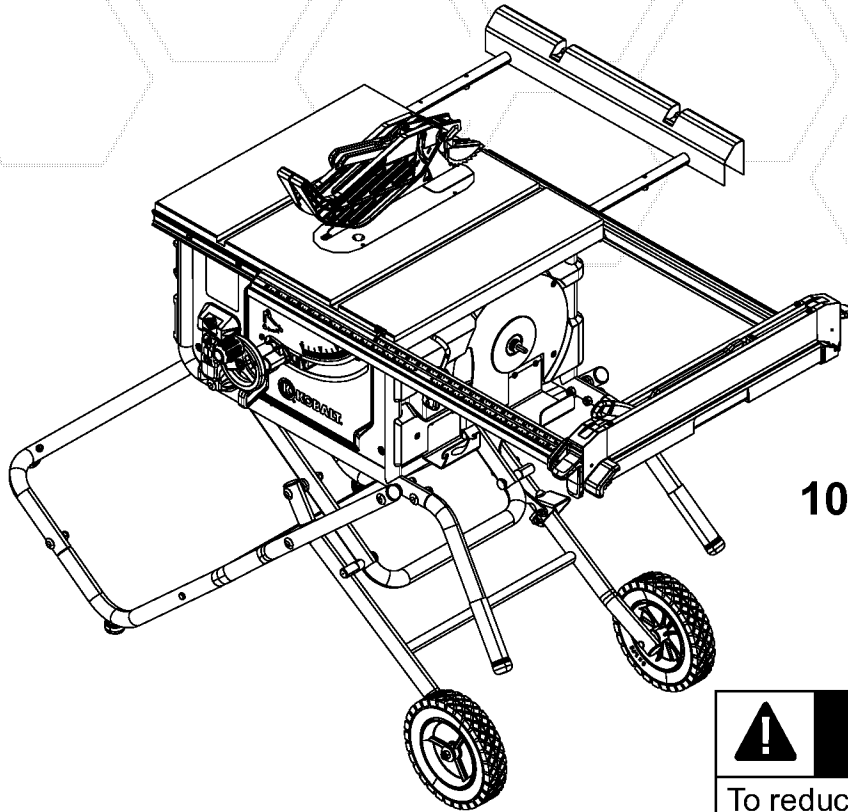

NEXT GENERATION OF TOUGH TOOLS™



ITEM #0486267

10 IN. TABLE SAW

MODEL #KT1015

Français p. 51

Español p. 102



WARNING

To reduce risk of serious injury, thoroughly read and comply with all warnings and instructions in this manual and on product.

KOBALT® and the K Design® are registered trademarks of LF, LLC. All Rights Reserved.

KEEP THIS MANUAL NEAR YOUR SAW FOR EASY REFERENCE AND TO INSTRUCT OTHERS

ATTACH YOUR RECEIPT HERE

Serial Number _____ Purchase Date _____



Questions, problems, missing parts? Before returning to your retailer, call our customer service department at 1-888-3KOBALT (1-888-356-2258), 8 a.m. - 8 p.m., EST, Monday - Friday.

AB13680B

kobalttools.com



TABLE OF CONTENTS

Package Contents	3
Hardware Contents.....	4
Safety Information	5
Power Connection	12
Assembly Instructions.....	14
Unpacking.....	15
Table Stand Assembly	15
Riving Knife Installation and Positioning.....	21
Blade Installation	22
Anti-Kickback Pawls Installation	23
Blade Guard Installation	24
Folding Leg Stand	25
Before Operating	26
Operating Components	26
Switch Assembly.....	26
Blades.....	27
Rip Fence	28
Miter Gauge.....	29
Outfeed Support	30
Slide Table Extension	30
Cutting Aids	31
How to Make a Push Stick.....	32
How to Make a Featherboard.....	33
How to Make a Push Block.....	33
Operating Instructions	35
Through-Cuts with Single Blades	35
Cutting Tips.....	35
Making Cuts.....	35
Types of Cuts.....	36
Dados and Other Non-Through-Cuts	39
Adjustments.....	40
Placing Knife in Lowered Position	40
Replacing Blade	41
Riving Knife and Saw Blade Alignment	42
Healing (Paralleling) Blade to Miter Gauge Groove	44
Setting Blade at 0° and 45°	45
Adjusting Bevel Indicator.....	46
Checking Alignment of Rip Fence to Miter Slot	46
Accessory Storage	46
Care and Maintenance	47
Troubleshooting.....	48
Warranty	49
Replacement Parts List	50

PACKAGE CONTENTS

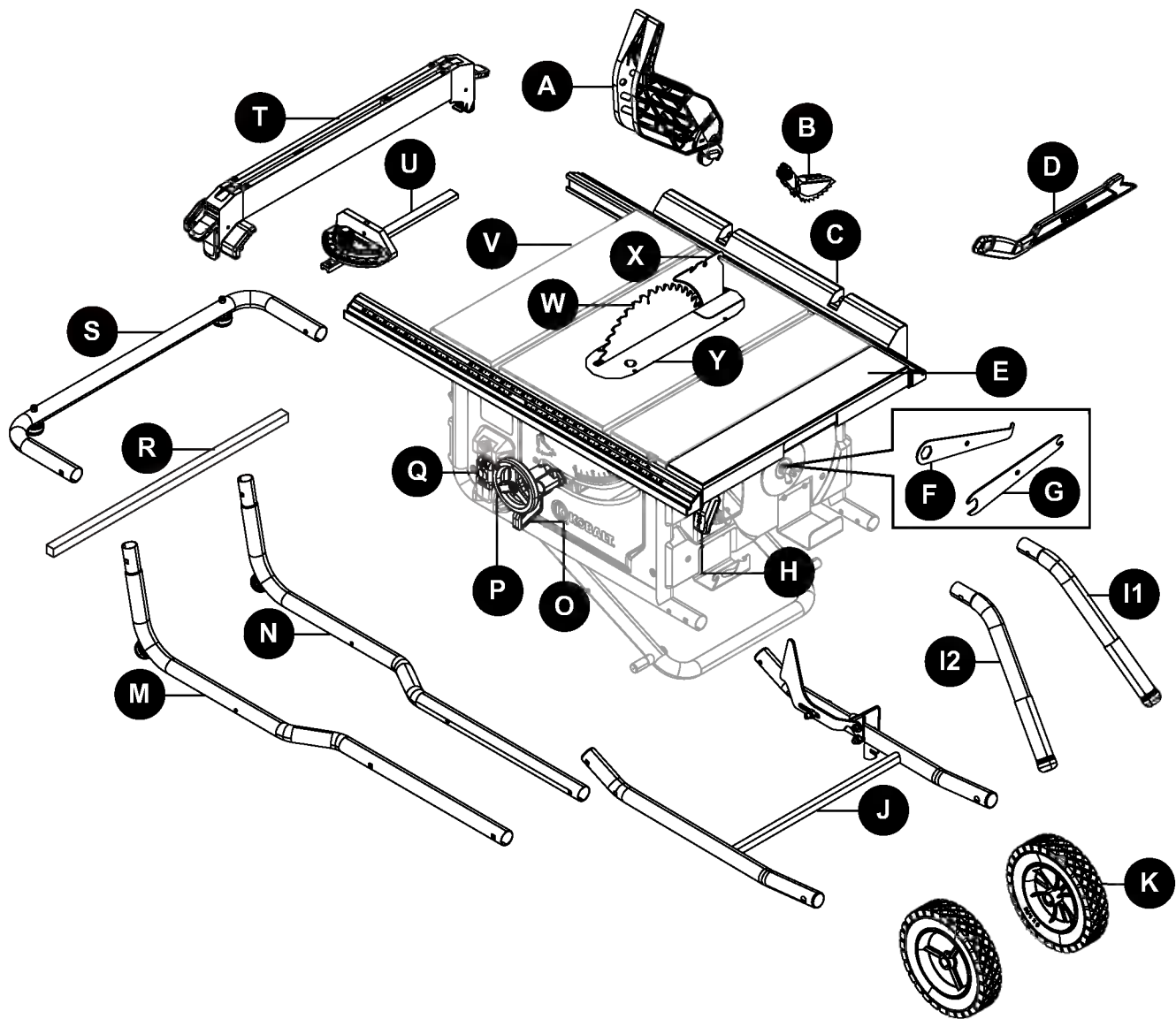

PART	DESCRIPTION	QUANTITY
A	Blade guard	1
B	Anti-kickback pawls	1
C	Out feed support	1
D	Push stick	1
E	Side table extension	1
F	Closed end wrench	1
G	Open end wrench	1
H	Side extension lock	1
I1, I2	Right and left handles	2
J	Lower right leg	1
K	Wheel	2
M	Left front leg	1

PART	DESCRIPTION	QUANTITY
N	Left rear leg	1
O	Release lever	1
P	Height adjusting wheel	1
Q	Off/On switch key	1
R	Left leg cross piece	1
S	Left leg end	1
T	Rip fence	1
U	Miter gauge	1
V	Table	1
W	Blade	1
X	Riving knife	1
Y	Throat plate	1

HARDWARE CONTENTS

AA

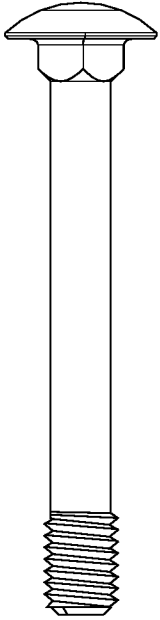

3 in. Cap screw

Qty. 6

BB

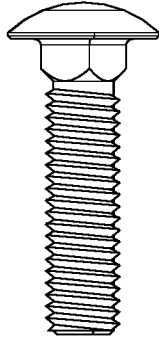

1-1/2 in. Cap screw

Qty. 4

CC

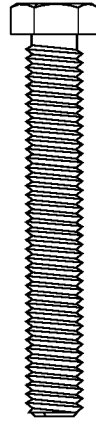

2 in. Bolt

Qty. 2

DD

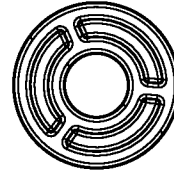

Spacer

Qty. 6

JJ



Nut
(preassembled
to lower right
leg assembly)

Qty. 2

EE

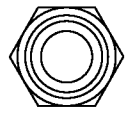

Nut

Qty. 10

KK

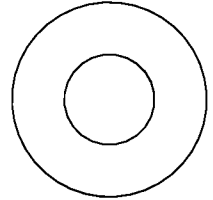

Washer
(preassembled
to lower right
leg assembly)

Qty. 4

FF

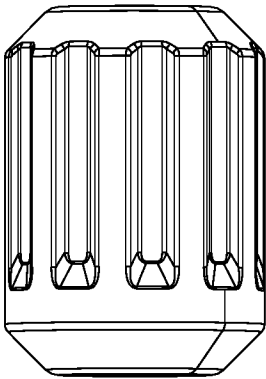

Height adjustment
knob

Qty. 1

GG

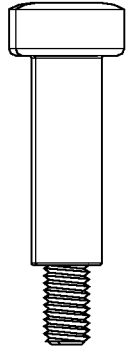

8 mm Hex bolt

Qty. 1

HH

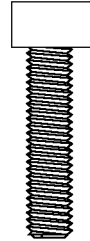

1 in. hex bolt

Qty. 2

IMPORTANT SAFETY INSTRUCTIONS

	WARNING
CAREFULLY READ AND FOLLOW ALL WARNINGS AND INSTRUCTIONS ON YOUR PRODUCT AND IN THIS MANUAL. SAVE THIS MANUAL. MAKE SURE ALL USERS ARE FAMILIAR WITH ITS WARNING AND INSTRUCTIONS WHEN USING THE TOOL. Improper operation, maintenance or modification of tools or equipment could result in serious injury and/or property damage.	

If you have any questions or concerns relative to the use of your tool or the contents of this manual, stop using the tool and contact customer service at 1-888-3KOBALT (1-888-356-2258), 8 a.m. - 8 p.m., EST, Monday - Friday.

DEFINITIONS – SAFETY SYMBOLS

The definitions below describe the level of severity for each signal word. Please read the manual and pay attention to these symbols.

	DANGER
Indicates an imminently hazardous situation which, if not avoided, will result in death or serious injury .	

	WARNING
Indicates a potentially hazardous situation which, if not avoided, could result in death or serious injury .	

	CAUTION
Indicates a potentially hazardous situation which, if not avoided, may result in minor or moderate injury .	

NOTICE

Indicates a practice **not related to personal injury** which, if not avoided, may result in **property damage**.

GENERAL POWER TOOL SAFETY

	WARNING
<ul style="list-style-type: none">• READ INSTRUCTION MANUAL AND KNOW YOUR TOOL. Read and familiarize yourself with entire instruction manual. Learning the tool's proper applications, limitations, and specific potential hazards will greatly minimize the possibility of accidents and injury. Make sure all users are familiar with its warnings and instructions before using tool.• KEEP GUARDS AND SAFETY DEVICES IN PLACE and working properly.• Failure to follow these rules may result in serious personal injury.	



SAFETY INFORMATION

- **REMOVE ADJUSTING KEYS AND WRENCHES.** Form habit of checking to see that all adjusting keys and wrenches are removed before starting tool.
- **KEEP WORK AREA CLEAN AND WELL LIT.** Cluttered or poorly-lit work areas, surfaces and benches can lead to accidents.
- **DO NOT USE OR STORE TOOL IN DANGEROUS ENVIRONMENTS.** Exposure to rain and damp or wet locations can result in shock or electrocution, or damage the tool. **DO NOT** operate electric tools near flammable liquids or in gaseous or explosive atmospheres. Motors and switches in these tools may spark and ignite fumes.
- **KEEP CHILDREN AND BYSTANDERS AWAY** from work area.
- **LOCK TOOLS AND WORK AREA.** Use padlocks, and master switches, or remove and store starter keys to prevent operation by children and other unauthorized users.
- **DO NOT FORCE TOOL OR WORKPIECE.** Operate tool at intended speed and feed rate for better and safer operation.
- **USE PROPER TOOL.** **DO NOT** force tool to do a task for which it was not designed.
- **DO NOT ABUSE POWER CORDS.** **NEVER** yank cord to disconnect from receptacle, crush cord, or expose it to heat, oil or sharp objects.
- **USE PROPER EXTENSION CORD.** If you use an extension cord, make sure it is in good condition and heavy enough to carry the current your product will draw. An undersized cord will cause a drop in line voltage, resulting in loss of power and overheating. See Extension Cord Chart for correct size depending on the cord length and data plate ampere rating. If in doubt, use the next smaller gauge number. The smaller the gauge number, the heavier the cord. When working outside, make sure extension cord is rated for outdoor use. Consult power connection section of this manual for Extension Cord Chart and power connection safety.
- **WEAR PROPER APPAREL.** **DO NOT** wear loose clothing, gloves, neckties, rings, bracelets, or other jewelry which may get caught in moving parts. Non-slip protective footwear is recommended. Wear protective hair covering to contain long hair.
- **WEAR PROPER EYE PROTECTION.** All persons in work area should wear safety glasses with side shields. Everyday eyeglasses with impact resistant lenses are not safety glasses. Eye equipment should comply with ANSI Z87.1 standards.
- **HEARING PROTECTION.** All people in work area should wear proper hearing protection consistent with noise levels and exposure. Hearing equipment should comply with ANSI S3.19 standards.
- **DUST PROTECTION.** Direct particles away from face and body. Always operate tool in well ventilated area and provide for proper dust removal. Use dust collection system whenever possible. Exposure to dust may cause serious and permanent respiratory or other injury, including silicosis (a serious lung disease), cancer, and death. Avoid breathing dust and avoid prolonged contact with dust. Allowing dust to get into your mouth or eyes, or lay on your skin may promote absorption of harmful material. Use properly fitting NIOSH/OSHA approved respiratory protection appropriate for the dust exposure and wash exposed areas with soap and water.
- **SECURE WORKPIECE.** Use clamps or a vise to hold the workpiece when practical. It is safer than using your hands and frees both hands to operate tool.
- **DO NOT OVERREACH.** Keep proper footing and balance to maintain control.
- **MAINTAIN TOOLS WITH CARE.** Keep tools sharp and clean for best and safest performance. Follow instructions for lubricating and changing accessories.
- **DISCONNECT TOOL** from power source before servicing, adjusting or changing set-ups or blades, bits, cutters and other accessories.
- **TO REDUCE RISK OF ACCIDENTAL STARTING,** make sure power switches are in “OFF” position before plugging tool in. **DO NOT** touch the plug’s metal prongs when unplugging or plugging in the cord.



SAFETY INFORMATION

- **USE RECOMMENDED ACCESSORIES.** Consult manual for recommended accessories. Use of inappropriate accessories may cause personal injury or property damage.
- **NEVER STAND ON TOOL.** Serious injury could occur if the tool tips or if you unintentionally contact the cutting surface.
- **CHECK TOOLS FOR DAMAGE.** Before using, and after tool or accessory has been dropped or damaged, check guards and affected parts for alignment of moving parts, binding of moving parts, breakage of parts, and any other condition that may affect its operation to make sure tool will operate properly and all parts will perform their intended function. **DO NOT** use a damaged product. A guard or any other part that is damaged should be properly repaired or replaced using factory-approved service parts.
- **USE PROPER FEED DIRECTION.** Feed workpiece against the direction of rotation of the tool's blade, cutter, or abrasive surface. Feeding in the other direction may cause the workpiece to be thrown at high speed.
- **NEVER LEAVE TOOL RUNNING UNATTENDED. TURN POWER OFF. DO NOT** leave tool until it comes to a complete stop. In the event of a power failure, move switch to "OFF" position.
- **STAY ALERT, WATCH WHAT YOU ARE DOING, AND USE COMMON SENSE. DO NOT** use power tools when tired or under the influence of drugs, alcohol, or medication. A moment of inattention while operating power tools may result in injury.
- **SERVICE PARTS.** Use only identical replacement parts when servicing your tool.

TABLE SAW SAFETY RULES



WARNING

- Failure to follow these rules may result in serious personal injury.

Terminology

The following terms will be used throughout the manual and you should become familiar with them.

- **Through cut** refers to any cut that completely cuts through the workpiece.
- **Non-through cut** refers to any cut that does not completely cut through the workpiece.
- **Push stick** refers to a wooden or plastic stick, usually homemade, that is used to push a small workpiece through the saw and keeps the operator's hands clear of the blade.
- **Kickback** occurs when the saw blade binds in the cut and thrusts the workpiece back toward the operator.
- **Freehand** refers to cutting without the use of a miter gauge or rip fence or any other means of guiding or holding the workpiece other than the operator's hand.
- **Plunge cutting** refers to blind cuts in the workpiece made by either raising the blade through the workpiece or lowering the workpiece down to the blade.
- **Resawing** – Flipping material to make a cut the saw is not capable of making in one pass.
- **Cove cutting** – Also known as coving, cove cutting is an operation where the work is fed at an angle across the blade.



WARNING

- **NEVER** perform freehand cutting.
- **NEVER** perform plunge cutting.
- Resawing is **NOT** recommended.

 **WARNING**

- To reduce the risk of personal injury, **DO NOT** perform cove cutting. Table saw blades are not designed for the excessive side loading needed.
- **SEE GENERAL POWER TOOL SAFETY SECTION OF THIS MANUAL.** Read entire instruction manual before operating saw. Learning the saw's proper applications, limitations, and specific potential hazards will greatly minimize the possibility of accidents and injury. Make sure all users are familiar with its warnings and instructions before using saw.
- **SEE POWER CONNECTION SECTION OF THIS MANUAL** for instructions and warnings regarding power cords and connections.
- **WEAR EYE PROTECTION**, appropriate apparel, hearing protection and dust protection as specified in the General Power Tool Safety Section of this manual.
- **USE SAW-BLADE GUARD, RIVING KNIFE AND ANTI-KICKBACK PAWLS.** Your saw is equipped with a modular blade guard, riving knife and anti-kickback pawl assembly, each module of which should be used for every possible operation, including all through cuts. This assembly is discussed in more detail below. Make sure modules are securely installed prior to operation.
- **KEEP HANDS AND OTHER BODY PARTS OUT OF THE BLADE PATH. NEVER** have any part of your body in line with the path of the saw blade.
- **USE A PUSH STICK** that is appropriate to the application to push and hold down a workpiece through the saw. A push stick is a wooden or plastic stick, usually homemade, that should be used whenever the size or shape of the workpiece would cause you to place your hands within 6 in. (152 mm) of the blade. Instructions for making a push stick are included in this manual.
- **AVOID KICKBACK.** Pay particular attention to instructions (below) on reducing risk of kickback.
- **NO FREEHAND CUTS.** Always use a miter fence, miter gauge, or other appropriate devices to guide or hold down the workpiece. Use hold-downs, jigs, fixtures or feather boards to help guide and control the workpiece. Accessories for use with your saw are available at extra cost from your local dealer or authorized service center.
- **DO NOT USE RIP FENCE AND MITER GAUGE AT THE SAME TIME.**
- **DO NOT REACH OVER/REACH AROUND. NEVER** reach over, in back of, or around, the cutting tool with either hand while the blade is in motion.
- **STABILITY.** Make sure table saw is properly assembled and located on a stable surface before use to keep saw from moving during cut.
- **PROPER ASSEMBLY. DO NOT** operate this saw until it is completely assembled and installed according to the instructions.
- **CHECK WORKPIECE AND SET-UP** before each operation. Knots, irregularities, or nails in workpiece and positioning mistakes or incomplete set-up may interfere with or affect saw performance and personal safety.
- **USE PROPER THROAT PLATE.** The proper throat plate must be in place and properly secured at all times to reduce the risk of a thrown workpiece and possible injury.
- **USE CORRECT BLADE AND RIVING KNIFE** for the intended operation. The blade must be installed to rotate toward the front of the saw. **DO NOT** use oversized blade or blade with incorrect arbor opening. Always tighten the blade arbor nut securely. Before use, inspect the blade for cracks or missing teeth. **DO NOT** use a damaged or dull blade. Always use blade within the thickness range for which the riving knife is designed.
- **AVOID AWKWARD OPERATIONS AND HAND POSITIONS** where a sudden slip could cause a hand to move into a saw blade. Operate with table at or near waist level for maximum balance and



SAFETY INFORMATION

control. Anticipate effect of workpiece size on your ability to adjust position and maintain control through completion of cut. It is not possible to control a large workpiece from a kneeling position.

- **KEEP ARMS, HANDS AND FINGERS AT LEAST SIX INCHES AWAY FROM THE BLADE.**
- **NEVER CUT METALS, CEMENT BOARD OR MASONRY.** Certain man-made materials have special instructions for cutting on table saws. Follow the manufacturer's recommendations at all times.
- **NEVER ATTEMPT TO FREE A STALLED BLADE OR TRAPPED WORKPIECE** without first turning the machine off and disconnecting the saw from the power source.
- **NEVER START THE MACHINE WITH THE WORKPIECE AGAINST THE BLADE** to reduce the risk of a thrown workpiece.
- **NEVER PERFORM LAYOUT, ASSEMBLY OR SET-UP WORK ON THE TABLE/WORK AREA** when the saw is running.
- **BEFORE LEAVING THE SAW**, wait for the blade to come to a complete stop, then disconnect from the power source, clean the table and work area, and lock out switch to prevent unauthorized use.
- **SUPPORT YOUR WORKPIECE** based on its size and the type of operation to be performed. Hold the work firmly against the fence and down against the table surface. **DO NOT** leave a wide panel or long board (or other workpiece) unsupported – the weight of the board may causes it to shift on the table resulting in loss of control.
- **AN UNFAMILIAR NOISE OR EXCESSIVE VIBRATION** may indicate a problem with your saw. If this happens, turn it off and disconnect it from the power source until the problem has been located and corrected. Contact customer service for assistance if the problem can not be solved.
- **OBTAIN ADVICE** from your supervisor, instructor, or another qualified person if you are not thoroughly familiar with the operation of this machine. Knowledge is safety.

SAW BLADE GUARD, ANTI-KICKBACK PAWLS AND RIVING KNIFE ASSEMBLY

- Your table saw is equipped with a blade guard, anti-kickback pawls and riving knife assembly that covers the blade and reduces the possibility of accidental blade contact. The riving knife is a flat plate that fits into the cut made by the saw blade and effectively fights kickback by lessening the tendency of the blade to bind in the cut. Two anti-kickback pawls are located on the sides of the riving knife that allow the wood to pass through the blade in the cutting direction but reduce the possibility of the material being thrown backwards toward the operator. The blade guard and anti-kickback pawls can only be used when making through cuts that sever the wood. When making rabbets and other non-through cuts, the blade guard and anti-kickback pawls must be removed and riving knife lowered to the non-through cut position marked on the riving knife.
- Use all components of the guarding system (blade guard assembly, riving knife and anti-kickback pawls) for every operation for which they can be used including all through cutting. If you elect not to use any of these components for a particular application, exercise additional caution regarding control of the workpiece, the use of push sticks, the position of your hands relative to the blade, the use of safety glasses, the means to avoid kickback and all other warnings contained in this manual and on the saw itself. Replace the guarding systems as soon as you return to through cutting operations. Keep the guard assembly in working order.

MAKING A PUSH STICK

- In order to operate your table saw safely, you must use a push stick whenever the size or shape of the workpiece would otherwise cause your hands to be within 6 in. (152 mm) of the saw blade or other cutter. A push stick is included with this saw.

SAFETY INFORMATION

- No special wood is needed to make additional push-sticks as long as they are sturdy and long enough. A length of 16 in. (400 mm) is recommended with a notch that fits against the edge of the workpiece to prevent slipping. It's a good idea to have several push sticks of the same length [16 in. (400 mm)] with different size notches for different workpiece thicknesses.
- The shape can vary to suit your own needs as long as it performs its intended function of keeping your hands away from the blade. Angling the notch so the push stick can be held at a 20-30 degree angle from the saw's table will help you to hold down the workpiece while also moving it through the saw. See push stick enclosed with your saw.

KICKBACKS

- Kickbacks can cause serious injury. A kickback occurs when a part of the workpiece binds between the saw blade and the rip fence, or other fixed object, and rises from the table and is thrown toward the operator. Kickbacks can be avoided by attention to the following conditions.

How to reduce the risk of kickbacks and protect yourself from possible injury

1. Be certain that the rip fence is parallel to the saw blade.
2. **DO NOT** rip by applying the feed force to the section of the workpiece that will become the cut-off (free) piece. Feed force when ripping should always be applied between the saw blade and the fence; use a push stick for narrow work, 6 in. (152 mm) wide or less.
3. Keep saw blade guard assembly, riving knife and anti-kickback assembly in place and operating properly. The riving knife must be in alignment with the saw blade and the anti-kickback assembly must stop a kickback once it has started. Check their action before ripping by pushing the wood under the anti-kickback assembly. The teeth must prevent the wood from being pulled toward the front of the saw. If any part of assembly is not operational, return your unit to the nearest authorized service center for repair.
4. Plastic and composite materials (like hardboard) may be cut on your saw. However, since these are usually quite hard and slippery, the anti-kickback pawls may not stop a kickback. Therefore, be especially attentive to following proper set up and cutting procedures for ripping.
5. Use saw blade guard assembly, anti-kickback assembly and riving knife for every operation for which it can be used, including all through-cut sawing.
6. Push the workpiece past the saw blade prior to releasing control.
7. **NEVER** rip a workpiece that is twisted or warped, or does not have a straight edge to guide along the fence.
8. **NEVER** saw a large workpiece that cannot be controlled.
9. **NEVER** use the fence as a guide or length stop when crosscutting.
10. **NEVER** saw a workpiece with loose knots, flaws, nails or other foreign objects.
11. **NEVER** rip a workpiece shorter than 10 in. (254 mm).
12. **NEVER** use a dull blade. A dull blade should be replaced or resharpened.



WARNING

PROPOSITION 65 WARNING: Dust created by power sanding, sawing, grinding, drilling, and other construction activities may contain chemicals known to the state of California to cause cancer, birth defects or other reproductive harm. Some examples are:

- Lead from lead-based paints
- Crystalline silica from bricks and cement and other masonry products
- Asbestos dust
- Arsenic and chromium from chemically-treated lumber

- Your risk from these exposures varies depending on how often you do this type of work. To reduce your exposure to these chemicals: work in a well-ventilated area and work with approved safety equipment, such as dust masks that are specially designed to filter out microscopic particles.
- Avoid prolonged contact with dust from power sanding, sawing, grinding, drilling, and other construction activities. Wear protective clothing and wash exposed areas with soap and water. Allowing dust to get into your mouth, eyes, or lay on the skin may promote absorption of harmful chemicals.



WARNING

- Use of this tool can generate and/or disburse dust, which may cause serious and permanent respiratory or other injury. Always use NIOSH/OSHA approved respiratory protection appropriate for the dust exposure. Direct particles away from face and body. Always operate tool in well-ventilated area and provide for proper dust removal. Use dust collection system wherever possible.

SAVE THESE INSTRUCTIONS

- Refer to them frequently.
- Use to instruct others who may use the tool.
- If tool is loaned to someone, also loan them these instructions.

POWER CONNECTION

EXTENSION CORDS



WARNING

- Keep the extension cord clear of the working area. Position the cord so it will not get caught on lumber, tools or other obstructions while you are working with a power tool. Failure to do so can result in serious personal injury.
- Check extension cords before each use. If damaged, replace immediately. Never use product with a damaged cord. Touching the damaged area could cause electrical shock resulting in serious injury.
- Use only 3-wire extension cords with 3-prong grounding plugs and 3-pole receptacles that accept the tool's plug. When using a power tool at a considerable distance from the power source, use an extension cord heavy enough to carry the current that the tool will draw. An undersized extension cord will cause a drop in line voltage, resulting in a loss of power and causing the motor to overheat. Use the chart below to determine the minimum wire size required for an extension cord. Only round, jacketed cords listed by Underwriter's Laboratories (UL) should be used.

Minimum Gauge Extension Cord				Minimum Gauge Extension Cord			
Ampere Rating	Volts	Total Cord Length in feet	Gauge of Extension Cord	Ampere Rating	Volts	Total Cord Length in feet	Gauge of Extension Cord
0-6	120	Up to 25	18 AWG	10-12	120	Up to 25	16 AWG
0-6	120	25-50	16 AWG	10-12	120	25-50	16 AWG
0-6	120	50-100	16 AWG	10-12	120	50-100	14 AWG
0-6	120	100-150	14 AWG	10-12	120	100-150	12 AWG
6-10	120	Up to 25	18 AWG	12-16	120	Up to 25	14 AWG
6-10	120	25-50	16 AWG	12-16	120	25-50	12 AWG
6-10	120	50-100	14 AWG	12-16	120	Greater than 50 feet not recommended	
6-10	120	100-150	12 AWG				

Note: AWG=American Wire Gauge

*Used on 12 gauge – 20 amp circuit

- When working with the tool outdoors, use an extension cord designed for outside use. This is indicated by the letters “W-A” or “W” on the cord’s jacket.
- Before using an extension cord, inspect it for loose or exposed wires and cut or worn insulation.

ELECTRICAL CONNECTION

- This product is powered by a precision built electric motor. It should be connected to a power supply that is 120 V, AC only (normal household current), 60 Hz. **DO NOT** operate this product on direct current (DC).
- A substantial voltage drop will cause a loss of power and the motor will overheat.
- If the saw does not operate when plugged into an outlet, double check the power supply.

POWER CONNECTION

SPEED AND WIRING

- The no-load speed of this tool is approximately 5,000 RPM. This speed is not constant and decreases under a load or with lower voltage.
- For voltage, the wiring in a shop is as important as the motor's horsepower rating. A line intended only for lights cannot properly carry a power tool motor. Wire that is heavy enough for a short distance will be too light for a greater distance. A line that can support one power tool may not be able to support two or three tools.



DOUBLE INSULATION

To reduce the risk of electric shock, this equipment has a polarized plug (one blade is wider than the other). This plug will fit in a polarized outlet only one way. If the plug does not fit fully in the outlet, reverse the plug. If it still does not fit, contact a qualified electrician to install the proper outlet.

DO NOT change the plug in any way.

PREPARATION

Before beginning assembly of product, make sure all parts are present. Compare parts with package contents list and hardware contents list. If any part is missing or damaged, **DO NOT** attempt to assemble the product.

Estimated Assembly Time: 45 minutes

Tools Required for Assembly (not included): Sharp knife or utility knife to cut carton, Phillips screwdriver, flathead screwdriver, combination square, framing square, tape measure or ruler, 13 mm open end wrench, 10 mm open end wrench or adjustable wrench, 8 mm Allen wrench, 5 mm Allen wrench.



WARNING

- **DO NOT** use this product if any parts on the Loose Parts List are already assembled to your product when you unpack it. Parts on this list are not assembled to the product by the manufacturer and require customer installation. Use of a product that may have been improperly assembled could result in serious personal injury.
- If any parts are damaged or missing, **DO NOT** operate this saw until the parts are replaced. Use of this product with damaged or missing parts could result in serious personal injury.
- **DO NOT** attempt to modify this saw or create accessories not recommended for use with this saw. Any such alteration or modification is misuse and could result in a hazardous condition leading to possible serious personal injury.
- **DO NOT** connect to power supply until assembly is complete. Failure to comply could result in accidental starting and possible serious personal injury.
- **DO NOT** lift the saw without help. Hold it close to your body. Keep your knees bent and lift with your legs, not your back. Ignoring these precautions can result in back injury.
- **NEVER** stand directly in line with the blade or allow hands to come closer than 6 in. to the blade. **DO NOT** reach over or across the blade. Failure to heed this warning can result in serious personal injury.
- **FULLY ASSEMBLE** saw with leg assembly prior to use. Leg assembly is an integral and necessary part of the support structure for this saw.

This product requires assembly.

- Carefully remove the upper piece of packaging material and leave the saw in the lower piece of packaging material.
- This tool is heavy. To avoid back injury, keep your knees bent and lift with your legs, not your back. Get help when needed.
- Inspect the tool carefully to make sure no breakage or damage occurred during shipping.
- **DO NOT** discard the packaging material until you have carefully inspected the tool, identified all loose parts, and satisfactorily operated the tool.
- The saw is factory set for accurate cutting. After assembling it, check for accuracy. If shipping has influenced the settings, refer to specific procedures explained in this manual.
- If any parts are damaged or missing, please call 1-888-356-2258 for assistance.

ASSEMBLY INSTRUCTIONS

UNPACKING

1. Cut sides of box at all four corners.

IMPORTANT: Before assembly, separate upper and lower packing trays. Leave base section in lower tray while completing steps 1 - 8.

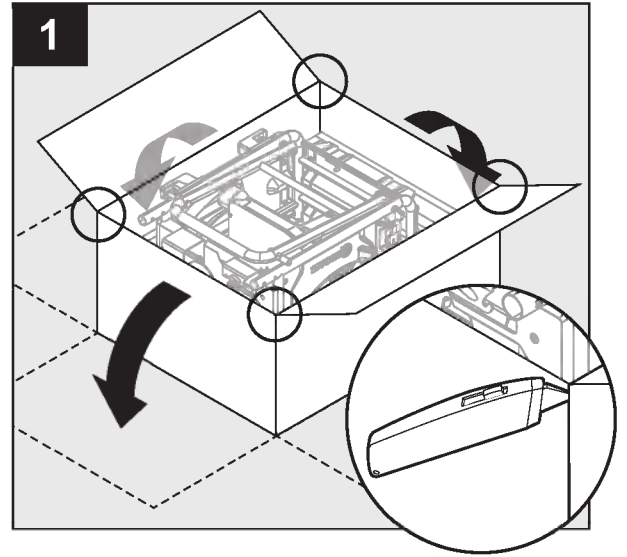
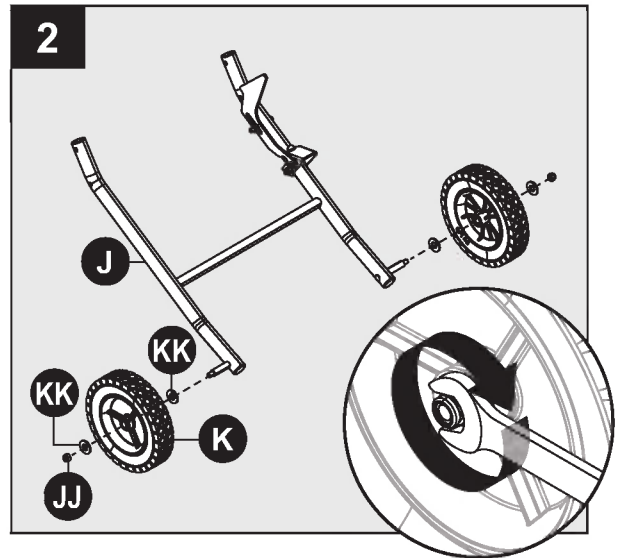
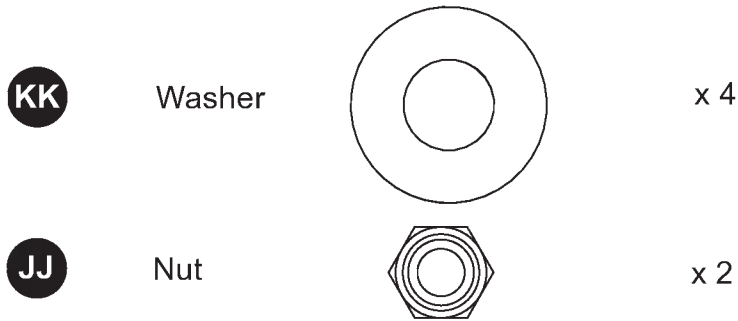

TABLE STAND ASSEMBLY

2. First remove washers (KK) and nuts (JJ) from lower right leg assembly, then attach wheels (K) to lower right leg assembly (J) with washers (KK) (one on each side of wheel) and nut (JJ). Check orientation of wheels and if wheels rub against frame, reverse orientation. Set wheel assembly aside for later use.



Hardware Used



3. Attach left leg cross piece (R) to left front leg (M) and left rear leg (N) with 1-3/8 in. bolts (CC).

Hardware Used

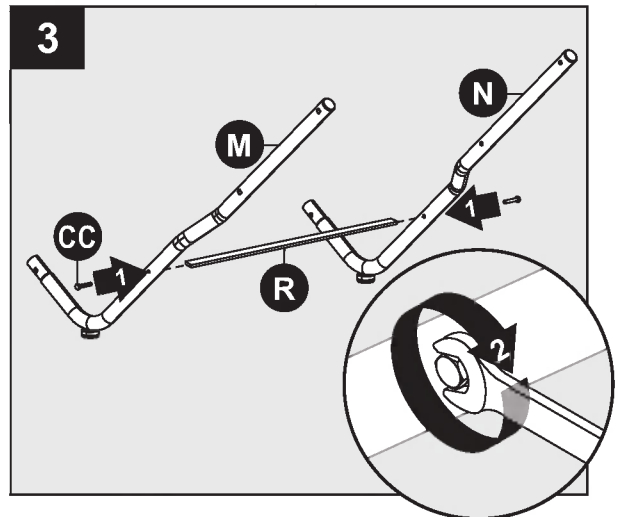
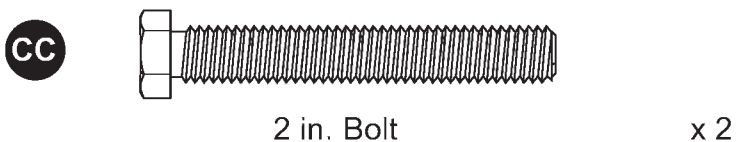

ASSEMBLY INSTRUCTIONS

4. Attach left leg end (S) onto the leg assembly from step 3. Secure with 1-1/2 in. cap screw (BB) and nut (EE).

Note: The feet on the left leg end (S) should face to the outside (left).

Hardware Used

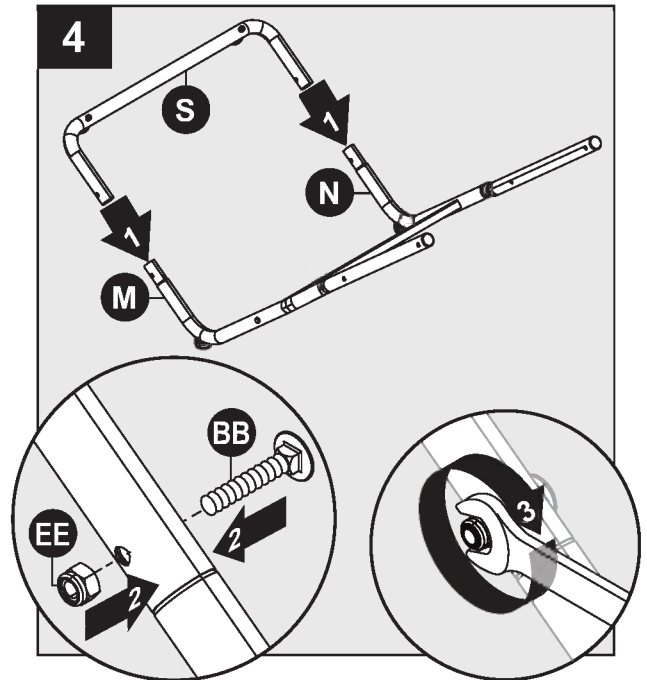
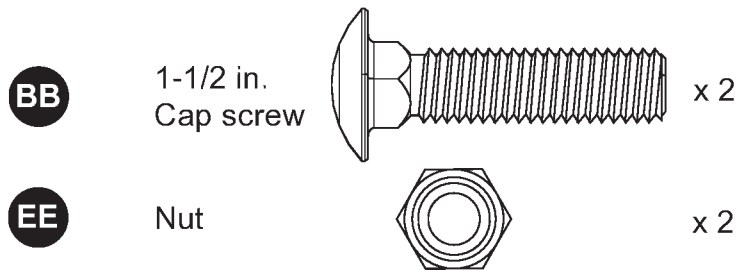

5. With table (V) still in lower packing tray, attach two handles (I1 & I2) to table (V) with 1-1/2 in. cap screw (BB) and nut (EE).

Note: Square and round holes can be aligned together.

Hardware Used

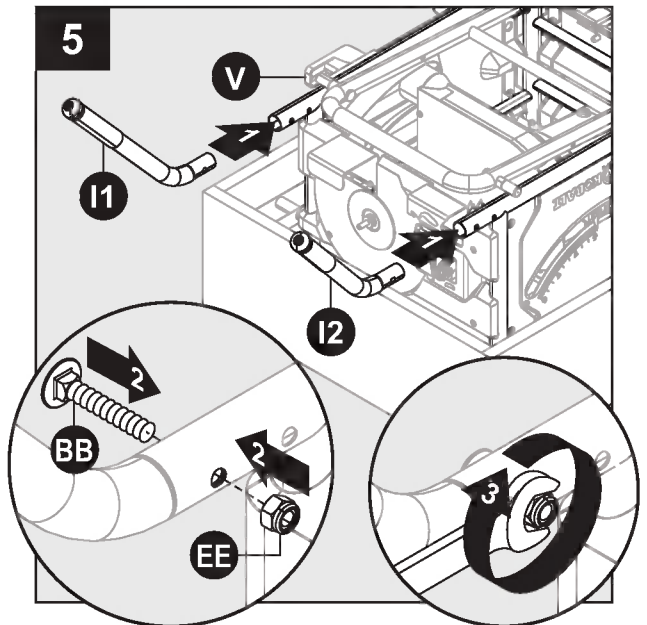
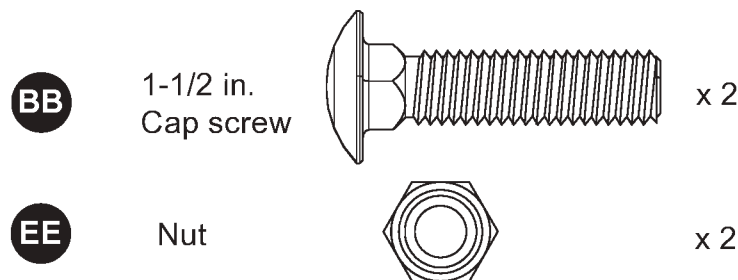

ASSEMBLY INSTRUCTIONS

6. Attach leg assembly to table (V). Insert spacer (DD) between legs and secure with 3 in. carriage bolt (AA) and nut (EE).

Note: Cut zip tie securing the preassembled upper leg in place.

Hardware Used

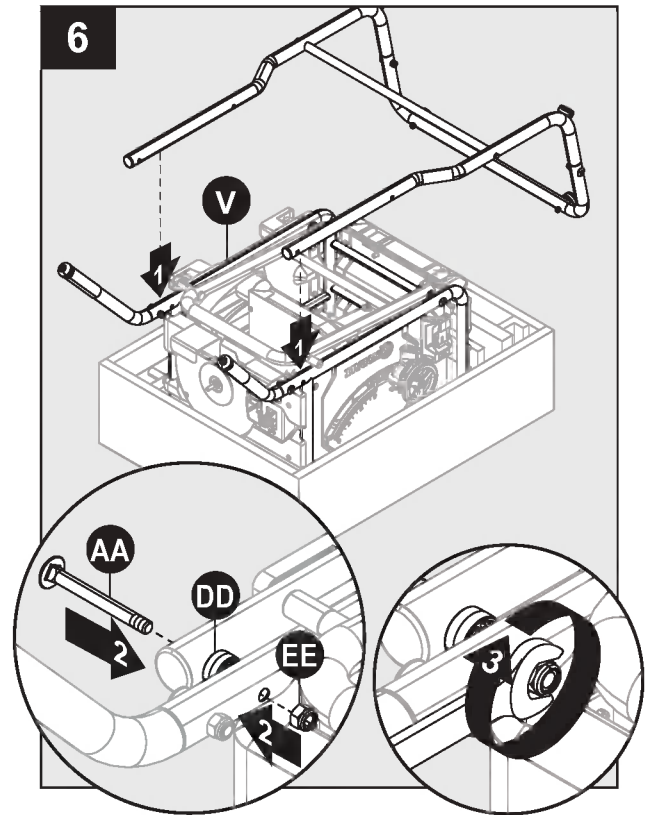
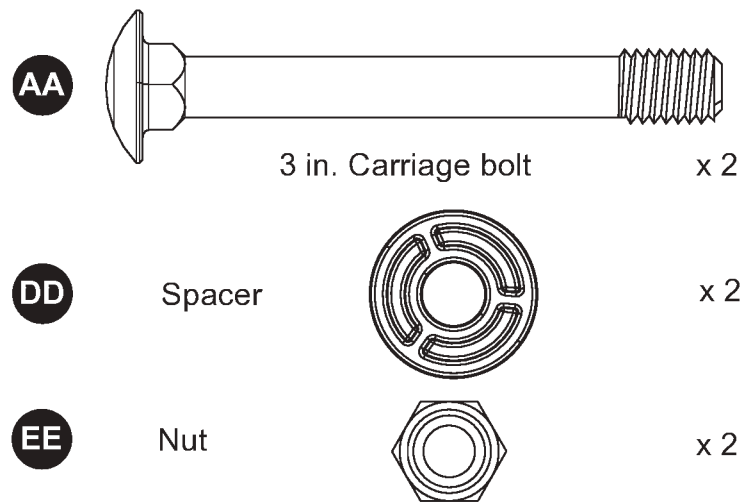

7a. Install the wheel assembly from step 2 to leg assembly installed in step 6. Insert spacer (DD) between legs and secure with 3 in. carriage bolt (AA) and nut (EE).

Hardware Used

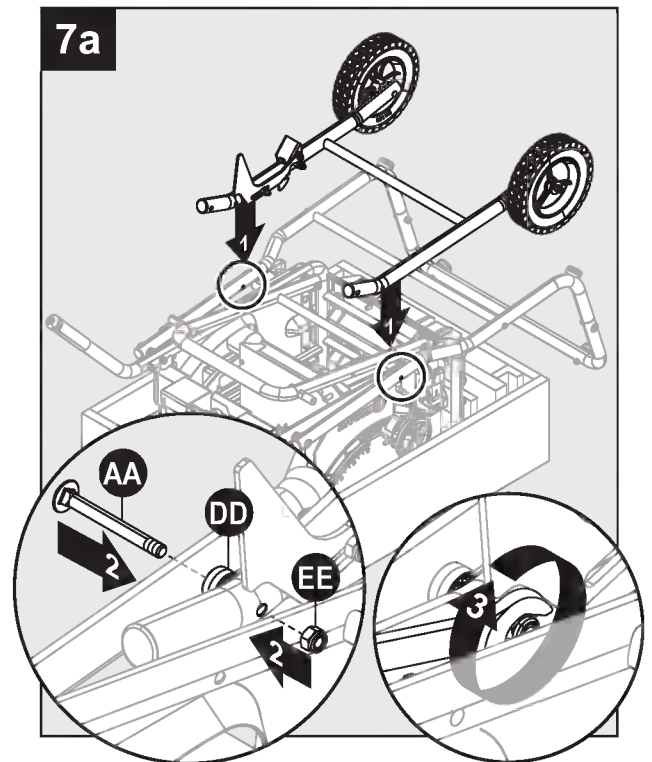
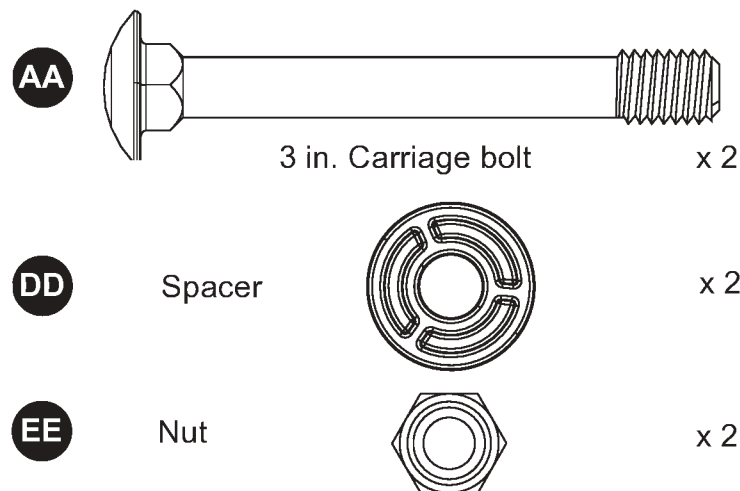

ASSEMBLY INSTRUCTIONS

7b. Raise the narrowest part of the stand to help align the holes. Insert spacer (DD) between legs and secure with 3 in. cap screw (AA) and nut (EE).

Note: DO NOT overtighten. Cut zip tie securing pedal.

Hardware Used

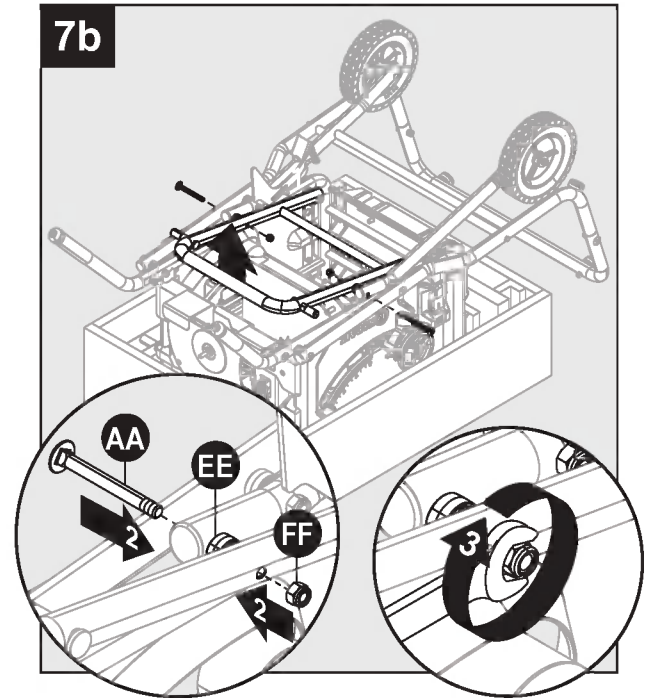
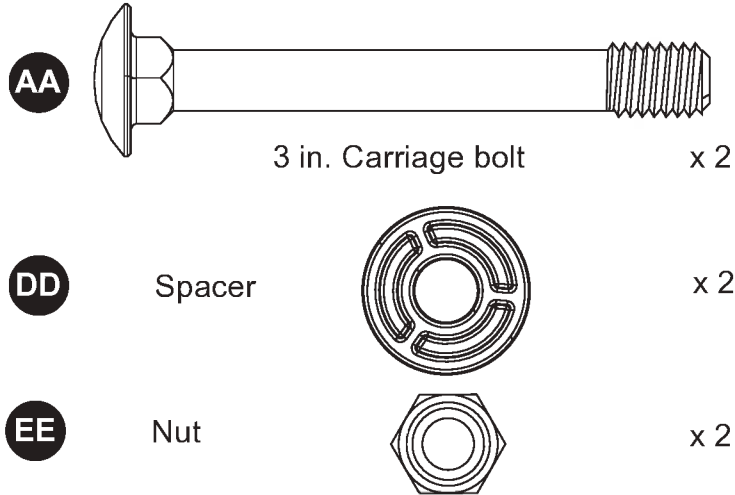

8. Grasp handles and tilt table saw back onto wheels. Remove table saw from packing tray. Let machine "stand" and tighten all screws.

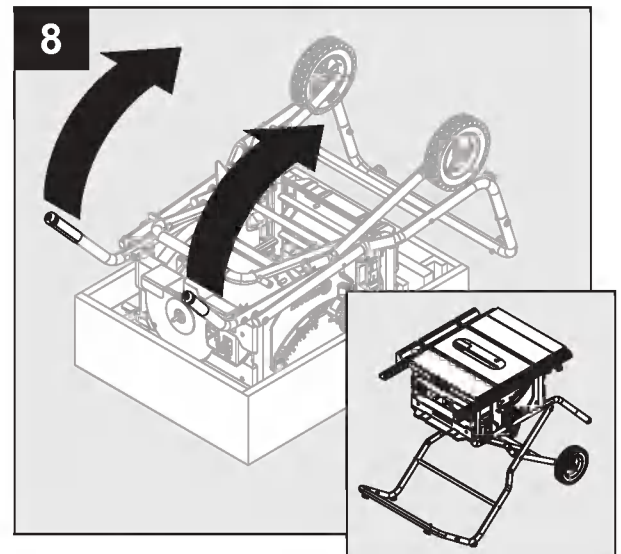

ASSEMBLY INSTRUCTIONS

9. **IMPORTANT:** Release height adjustment locking lever and tilt blade to 45° to release and remove packing material under motor.

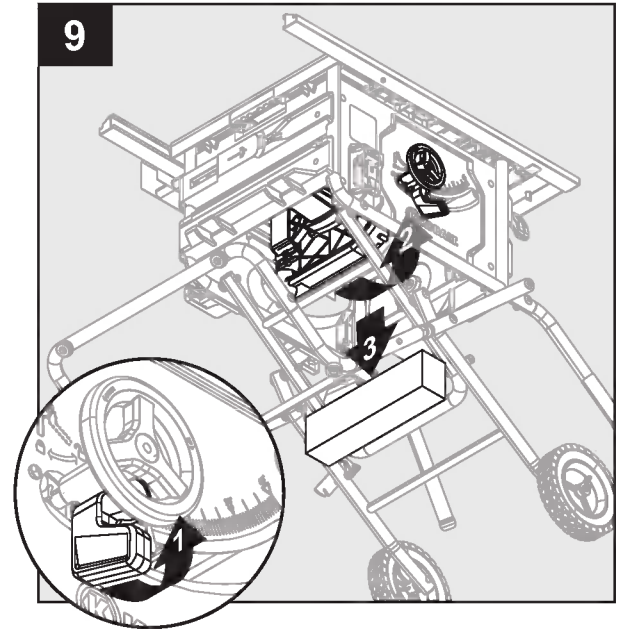

10. Install height adjustment knob (FF) and hex bolt (GG) to height adjustment wheel.

Hardware Used

GG 8 mm Hex bolt

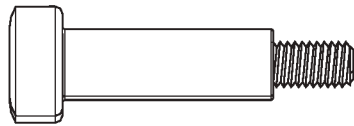

FF Height adjustment knob

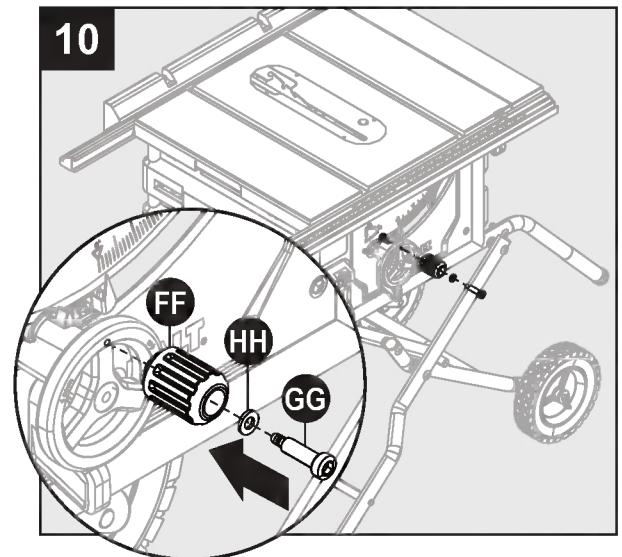
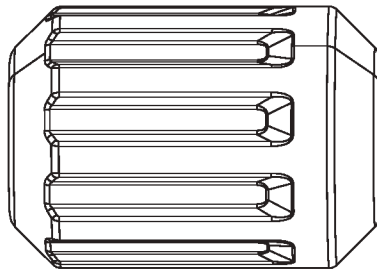

ASSEMBLY INSTRUCTIONS

11. Stand behind saw. Grasp out feed support (C) with both hands and pull until it is fully extended. Install hex bolts (HH) to secure.

Hardware Used

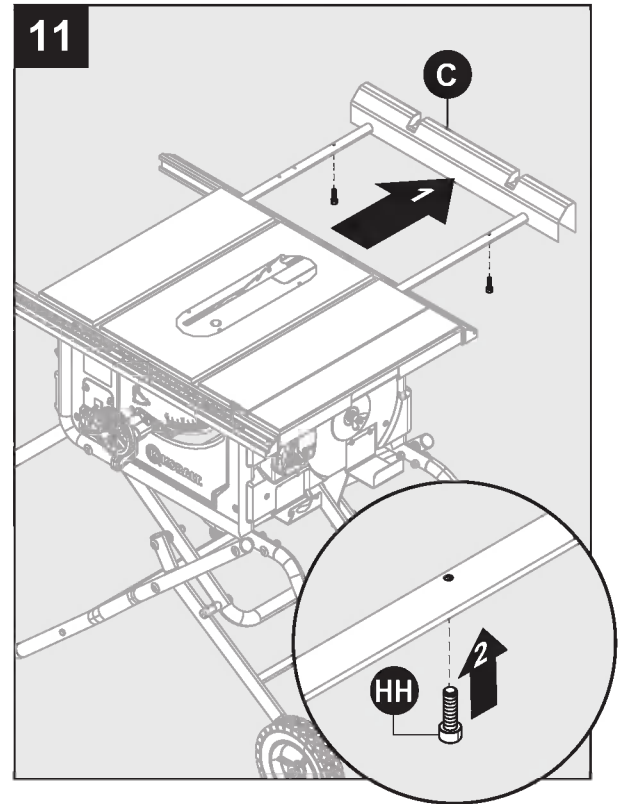

ASSEMBLY INSTRUCTIONS

RIVING KNIFE INSTALLATION AND POSITIONING

Note: This saw is shipped with riving knife in lowered position for non-through cuts. Riving knife must be placed in raised position to attach anti-kickback pawls and blade guard for all through cut operations.

Note: 0.087 in. (2.2 mm) thick riving knife. Only use for 10 in. (254 mm) blade width. 0.01 in. (2.6 mm) min. kerf width and 0.073 in. (1.85 mm) max body thickness.

To place riving knife in raised position (for through cuts):

1. Raise blade (W) all the way to highest position by turning height adjusting wheel (P) clockwise.

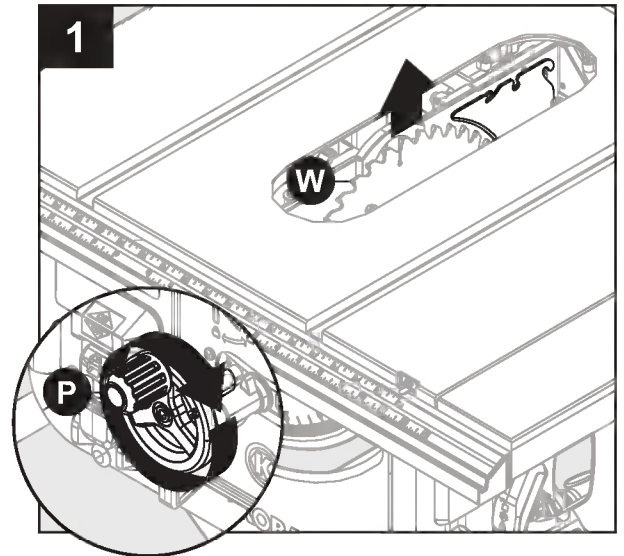

2. Unscrew riving knife lock knob with fingers. Then push in on loosened knob to release riving knife. Grasp riving knife (X) and pull toward right side of saw to release it from spring-loaded riving knife clamp. Notice the different riving knife height positions. Position the riving knife in the raised position with the through-cut position (marked on the riving knife), level with tabletop.

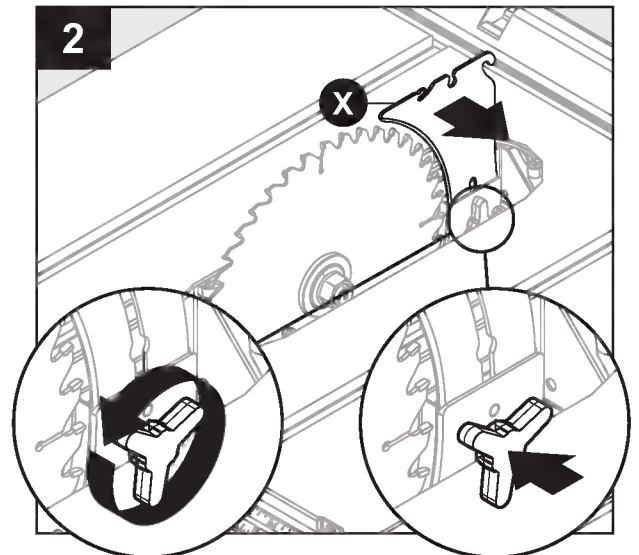

ASSEMBLY INSTRUCTIONS

BLADE INSTALLATION

CAUTION

- To work properly, saw blade teeth must point down toward the front of the saw. Failure to do so could cause damage to the saw blade, the saw, or the workpiece.

1. Make sure blade is turned right way. Remove blade wrenches from storage area. Install blade and washer (with small side facing outward), then apply nut to shaft. Place open end wrench (G) on flats of arbor shaft. Insert closed end wrench (F) over blade nut.

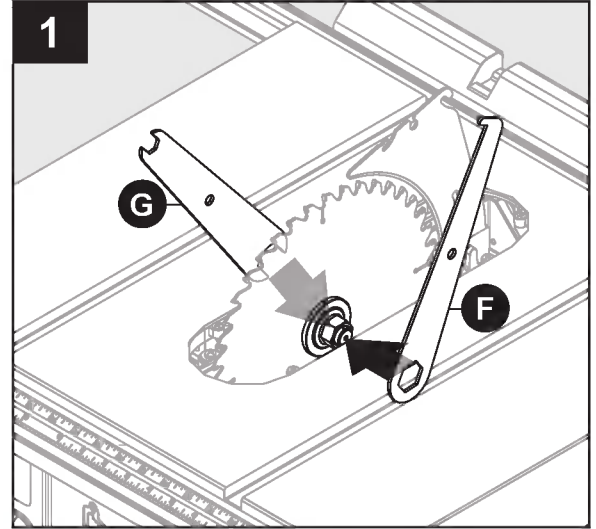

To tighten the blade:

2. Holding both wrenches firmly, push closed end wrench (F) to back of machine. Make sure blade nut is securely tightened. **DO NOT** over tighten. Reinstall the throat plate (Y). Check all clearances for free blade rotation.

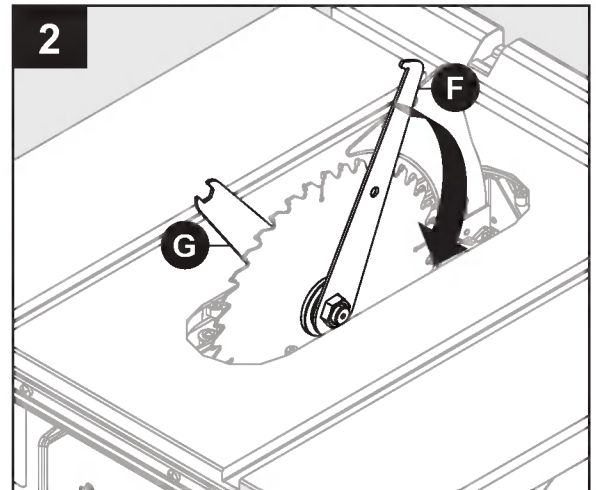

ASSEMBLY INSTRUCTIONS

3. To install throat plate (Y), slip tab into slot at back of saw and push down to secure in place.

Note: There are five screws pre-assembled to the table (V) located under the throat plate that can be used for leveling the throat plate if necessary.

NOTICE

These five screws should not be used to fasten the throat plate to the table. They are for leveling purposes only.

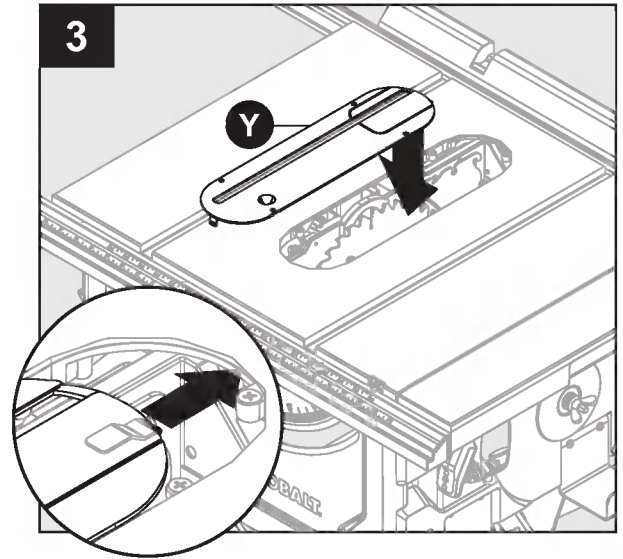
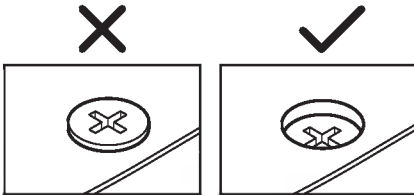

ANTI-KICKBACK PAWLS INSTALLATION

- Anti-kickback pawls should only be installed for through cuts.



WARNING

- Replace dull or damaged anti-kickback pawls. Dull or damaged anti-kickback pawls may not stop a kickback, increasing the risk of serious personal injury.

1. Unplug saw. Raise blade (W) by turning height adjusting wheel (P) clockwise. Place riving knife (X) in raised position. Press and hold button on right side of anti-kickback pawls (B). Align slot in anti-kickback pawls (B) over center slot of riving knife (X).
2. Push anti-kickback pawls (B) down until it snaps into place and release button.

Note: Pull up on anti-kickback pawl assembly to make sure it is secured to riving knife.

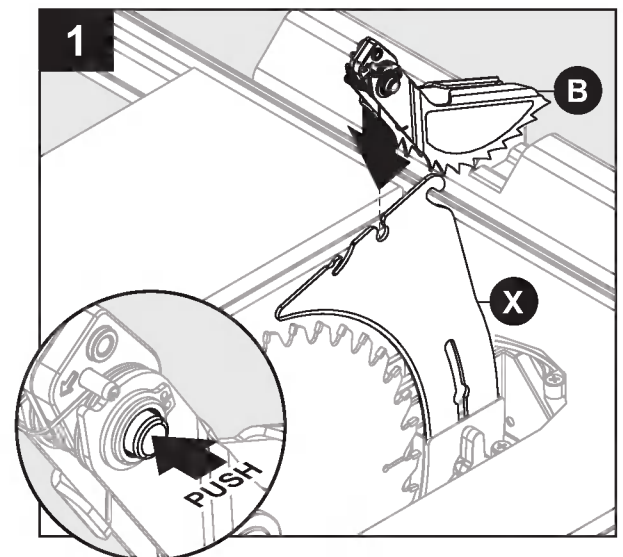

ASSEMBLY INSTRUCTIONS

BLADE GUARD INSTALLATION

To install blade guard:

1. With front of blade guard (A) raised, hook back end of guard onto rear slot of riving knife (X).

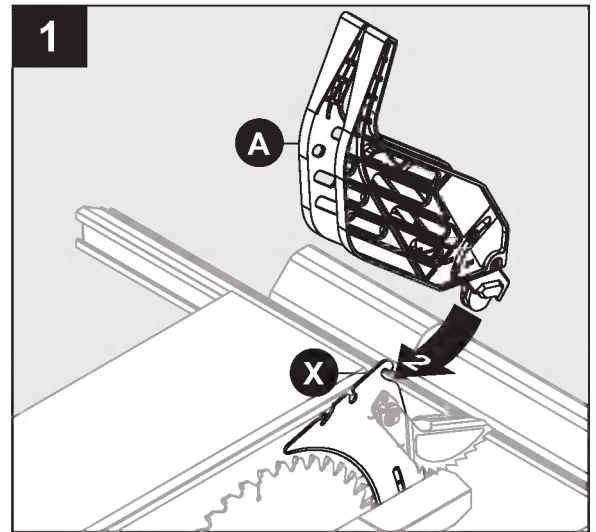

2. Push front down until it is parallel to table. Lock blade guard (A) in place by pushing lever down.

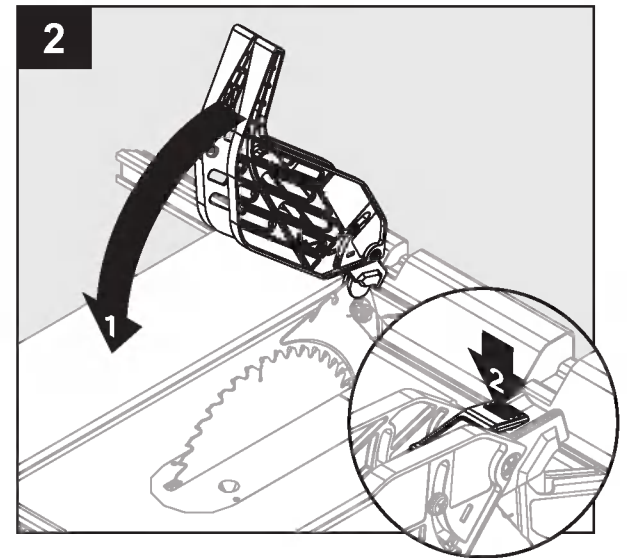

3. If blade guard (A) is not parallel to table, riving knife (X) is not in raised (through cut) position.

Note: Blade alignment with riving knife can be adjusted. See: **Checking and Aligning Riving Knife and Saw Blade, page 41.** Check the blade guard (A) for clearances and free movement.

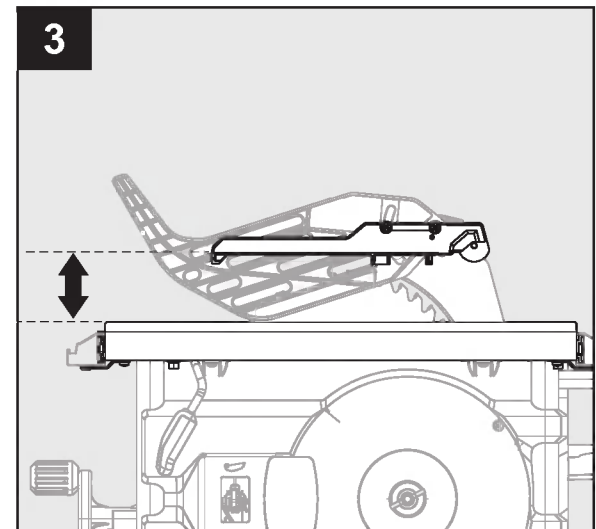

FOLDING LEG STAND

1. To fold stand for moving, return side and rear extension tables to inner position. Stow rip fence and miter gauge. Grasping handles, push the stand release pedal with your foot and tilt up and forward until the saw rests on the wheels and stand feet.

STORAGE FEATURES

- The table saw has two convenient storage areas (one on either side of saw cabinet) specifically designed for storage.
- When not in use, store rip fence, blade wrenches, miter gauge, push stick and blades by securely snapping each in place.

2. Table saw can be moved to proper storage area.

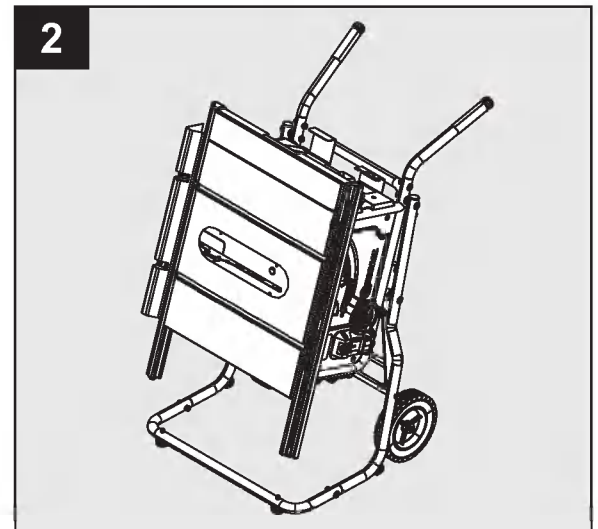
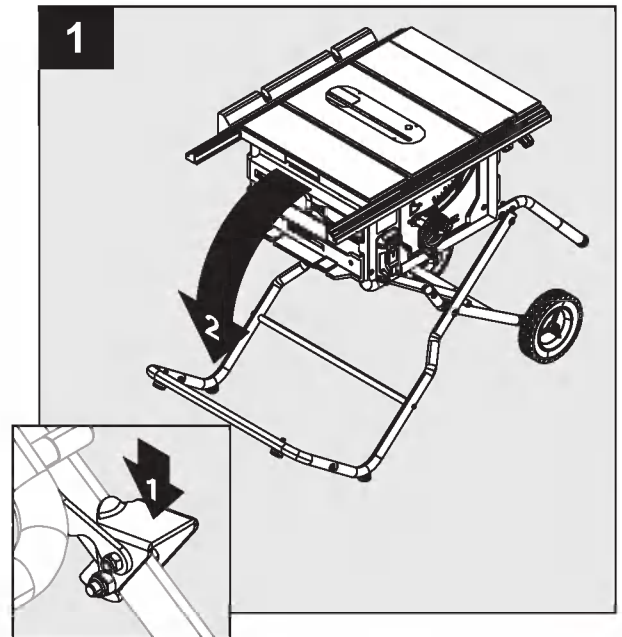

BEFORE OPERATING



WARNING

- **ALWAYS** remove the off/on switch key (Q) when the saw is not in use and keep it in a safe place. In the event of a power failure, turn the switch off and remove the key to prevent the saw from accidentally starting when power returns.
- **ALWAYS** make sure your workpiece is not in contact with the blade (W) before operating the switch to start the saw. Blade contact could result in kickback or thrown workpiece.
- To reduce the risk of accidental starting, **ALWAYS** make sure the switch is in the off position before plugging saw into the power source.
- **DO NOT** use blades rated less than the speed of this tool. Failure to heed this warning could result in serious personal injury.

OPERATING COMPONENTS

- The upper portion of the blade (W) projects up through the table (V) and is surrounded by an insert called the throat plate (Y). The height of the blade (W) is set with a height adjust wheel (P) on the bevel adjustment assembly. Detailed instructions are provided in this manual for the basic cuts: cross cuts, miter cuts, bevel cuts, and compound cuts.
- The rip fence (T) is used to position work for lengthwise cuts. A scale on the front rail shows the distance between the rip fence (T) and the blade (W).
- It is very important to use the blade guard assembly for all through-cut sawing operations. The blade guard assembly includes: riving knife (X), anti-kickback pawls (B), and blade guard (A).

SWITCH ASSEMBLY

This saw is equipped with a switch assembly that has a built-in locking feature. This feature is intended to prevent unauthorized and possibly hazardous use by children and others.

Turning saw on and off:

1. Ensure that the off/on switch key (Q) is inserted into the switch.
2. Lift the switch to turn on the saw.
3. Press the switch down to turn off the saw.

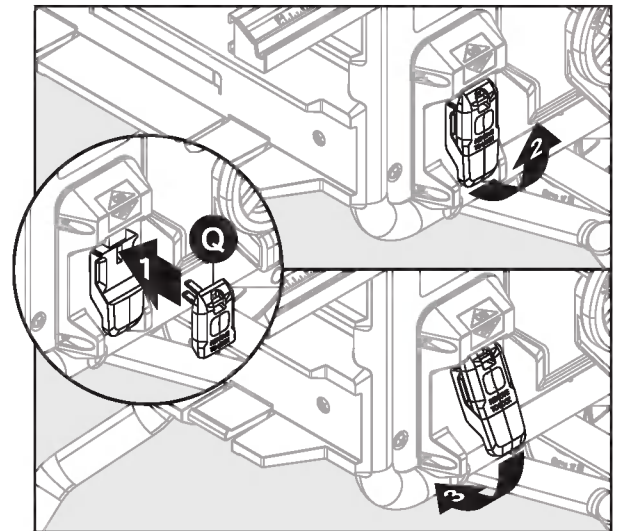

BEFORE OPERATING

BLADES

- Your saw comes equipped with a 10 in. combination blade suitable for ripping and cross-cutting. Additional blade styles are available for specific operations such as ripping. Your local dealer can provide you with complete information.
- Kerf width must be within the limits stamped on the riving knife (X).

Changing Blade Depth

Blade depth should be set so that outer points of blade (W) are higher than workpiece by approximately 1/8 in. to 1/4 in. and bottom of gullets are below top surface of workpiece.

1. Make sure release lever (O) is locked (in down position).
2. Raise blade (W) by turning height adjusting wheel (P) clockwise. Lower blade (W) by turning height/bevel adjusting wheel (P) counterclockwise.
3. Make sure blade (W) is at proper height.

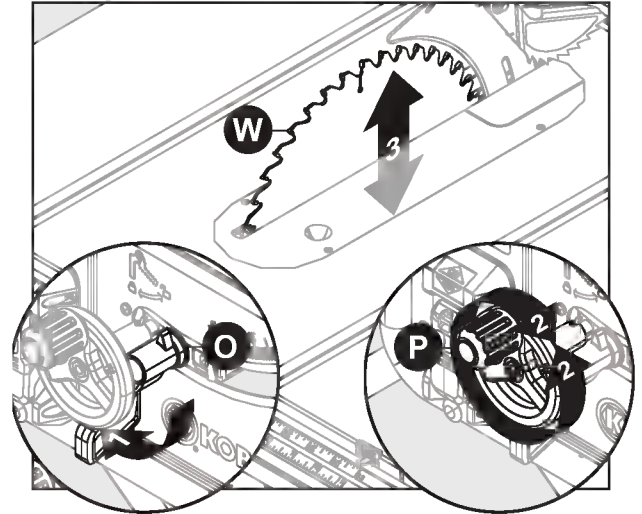

Changing Blade Angle (Bevel)

Note: A 90° cut has a 0° bevel and a 45° cut has a 45° bevel.

Note: If bevel indicator is not at zero when saw blade is at 0°, see Adjusting Bevel Indicator, page 46.

1. Loosen bevel control by pulling release lever (O) all the way to the right.
2. Adjust bevel angle by first pushing height adjusting wheel assembly all the way to the left.
3. Holding knob/wheel, slide bevel indicator to the right to increase angle of blade (W) (bringing it closer to 45° from the tabletop). Holding knob/wheel, slide bevel indicator to the left to decrease the angle (bringing blade closer to 90° from the tabletop).
4. Make sure blade (W) is at desired angle. Tighten bevel control by pushing release lever (O) to the left.

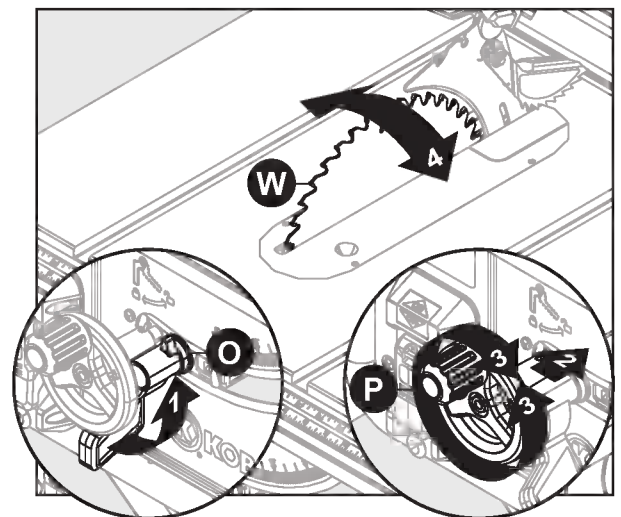

BEFORE OPERATING

RIP FENCE



WARNING

- To reduce the risk of injury, always make sure the rip fence (T) is parallel to the blade (W) before beginning any operation. **Using Rip Fence**

1. Place rip fence (T) flat on table (V).
2. Push rip fence (T) toward front rail to align fence to table (V).
3. Push locking lever down slowly to automatically align and secure fence.
4. Lock rear lever.

Setting Rip Fence Scale Indicator

- Use indicator on rip fence (T) to position fence along scale on front rail.

1. Loosen rip fence (T) by lifting front and rear locking levers. Use a tape measure or ruler to measure 6 in. and move fence until it aligns with measured distance.

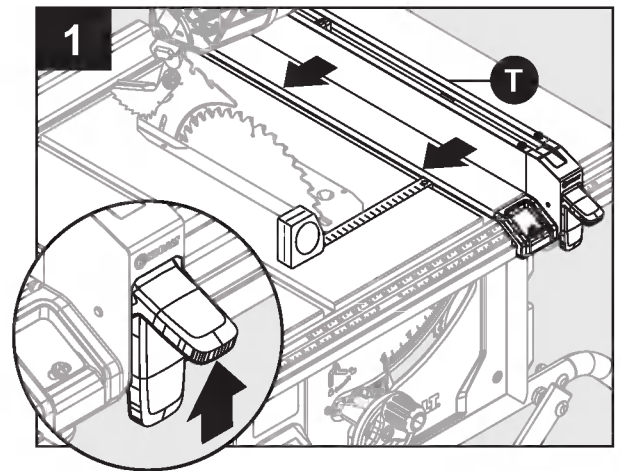

2. Scale indicator should align with 6 in. mark on fence as shown.
3. To adjust scale indicator, loosen screw as shown and align scale indicator with 6 in. mark on fence. Then retighten screw.

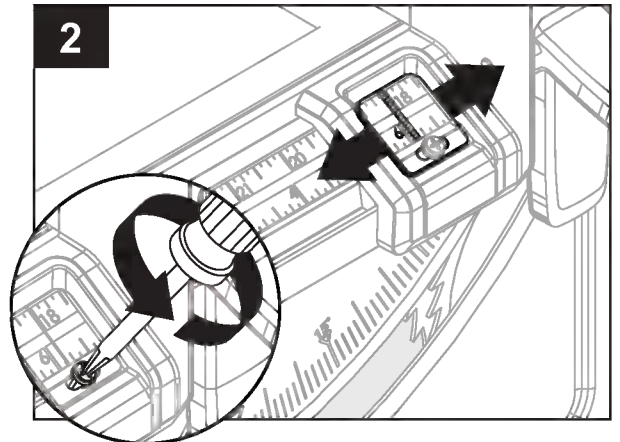

BEFORE OPERATING

MITER GAUGE

The miter gauge provides accuracy in angled cuts. For very close tolerances, test cuts are recommended.

There are two miter gauge grooves, one on either side of blade. When making a 90° cross cut, use either miter gauge groove. When making a beveled cross cut (blade tilted in relation to table (V), miter gauge should be located in groove on right so that blade is tilted away from miter gauge and hands.

Using Miter Gauge

1. Loosen lock knob. With miter gauge in miter gauge groove, rotate gauge until desired angle on scale is reached. Retighten lock knob.

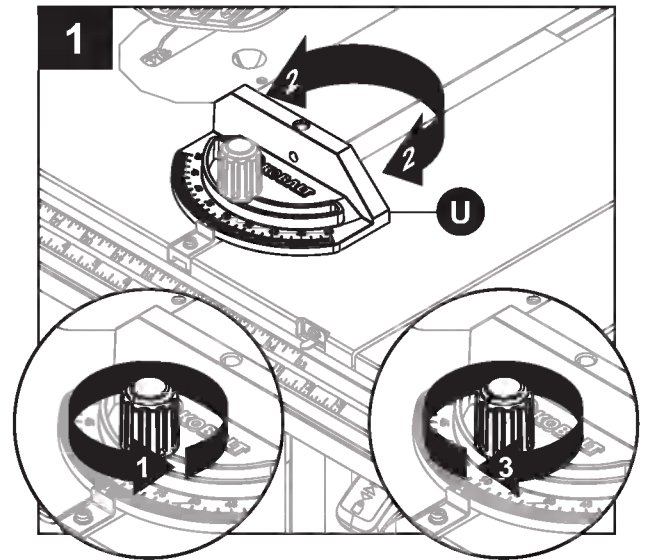

BEFORE OPERATING

OUT FEED SUPPORT

The out feed support (C) slides to give operator additional support for cutting long work pieces.

1. With table saw in off position, stand behind saw. Grasp out feed support (C) with both hands and pull until it is fully extended.

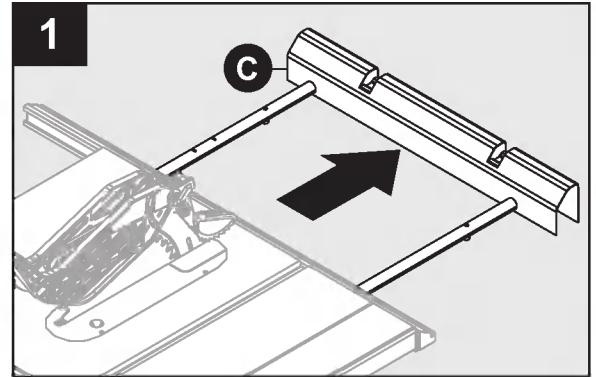

SLIDING TABLE EXTENSION

Increase the length of the saw table (V) by using the table extension (E).

1. For rip cuts between 13 in. and 30 in., set rip fence (T) to 13 in. (far right on lower scale).

Note: With rip fence set at 13 in., use top scale on front rail to set desired width.

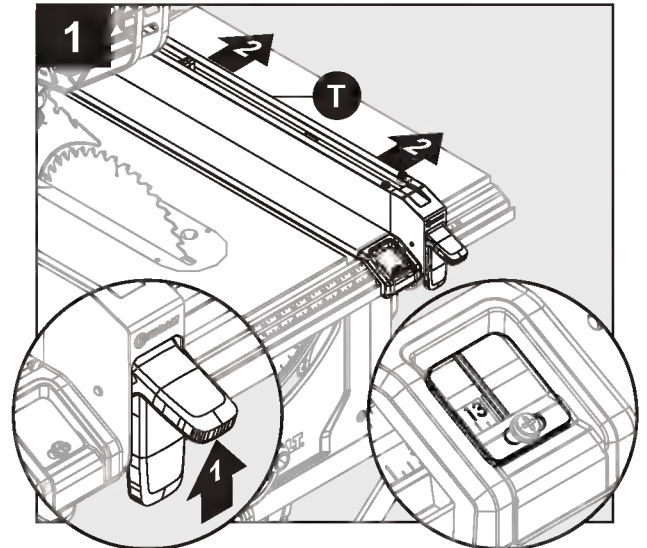

2. Release the extension table slide lever by pulling side extension lock (H) outward. Slide side table extension (E) out to the right. Use the blue pointer on the top scale to determine desired distance. When side table extension (E) is set to desired width, re-lock lever.

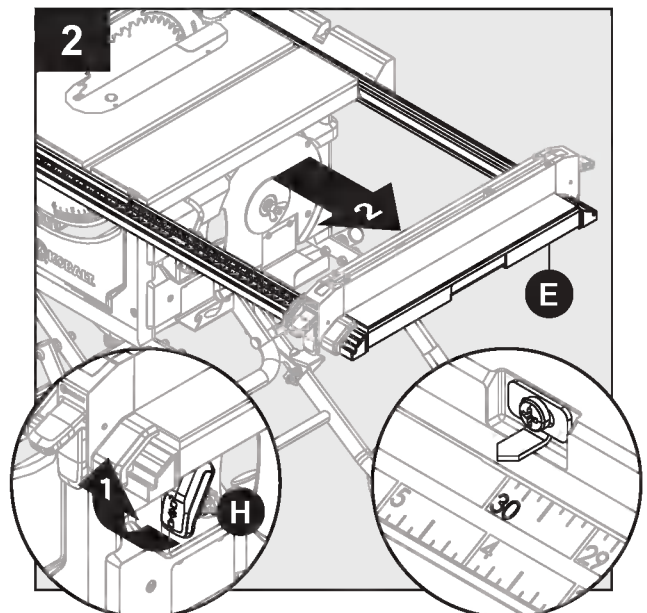

BEFORE OPERATING

CUTTING AIDS

Cutting aids such as push sticks, push blocks, featherboards and jigs should be used where appropriate to maximize your ability to control your workpiece for a safe and precise cut.

When making non-through cuts or ripping narrow stock, always use a push stick, push block, featherboard and/or jig set-up so hands do not come within 6 inches of saw blade (W).

A push stick is included with your saw. Additional push sticks and other cutting aids can be purchased separately at any authorized dealer. Instructions for making cutting aids can be found at on pages 32-34.

Push Sticks

Push blocks can be purchased or made to securely hold down the workpiece against the table when making non-through cuts. They should include a gripping surface on the bottom and a handle to hold the block. Any screws running through the underside of the block to fasten the handle should be recessed in order to avoid contact with the workpiece

Push Blocks

Push blocks are blocks used to securely hold down the workpiece against the table. They include some gripping surface or handle to hold the block. Any screws running through the underside of the block to fasten the handle should be recessed in order to avoid contact with the workpiece.

Featherboards

A featherboard is a device used to help control the workpiece by guiding it securely against the table (V) or rip fence (T). Featherboards are especially useful when ripping small workpieces and for completing non-through cuts. The end is angled with a series of narrow slots to give a friction hold on the workpiece. It is locked in place on the table (V) with a C-clamp.



WARNING

- When using featherboard, it must be mounted in front of the saw blade and used only against the uncut portion of the workpiece to avoid a kickback that could result in serious injury.

Jigs

Jigs may be created with a variety of special set-ups to control particular workpiece shapes for particular cuts. Guidance on how to make specialized jigs can be found in woodworking magazines and other reference sources.



WARNING

- Do not attempt to create a jig unless you are thoroughly familiar with table saw safety. Do not use any jig that could result in pinching of a kerf or jamming of the workpiece between the jig and the blade. Incorrect setups may cause kickback which could result in serious injury.

BEFORE OPERATING

*Some materials mentioned in this section are sold separately.

HOW TO MAKE A PUSH STICK

- In order to operate your table saw safely, you must use a push stick whenever the size or shape of the workpiece would otherwise cause your hands to be within 6 in. (152 mm) of the saw blade or other cutter. A push stick is included with this saw.
- No special wood is needed to make additional push-sticks as long as it's sturdy and long enough. A length of 15.7 in. (400 mm) is recommended with a notch that fits against the edge of the workpiece to prevent slipping. It's a good idea to have several push sticks of the same length [15.7 in. (400 mm)] with different size notches for different workpiece thicknesses.
- The shape can vary to suit your own needs as long as it performs its intended function of keeping your hands away from the blade.

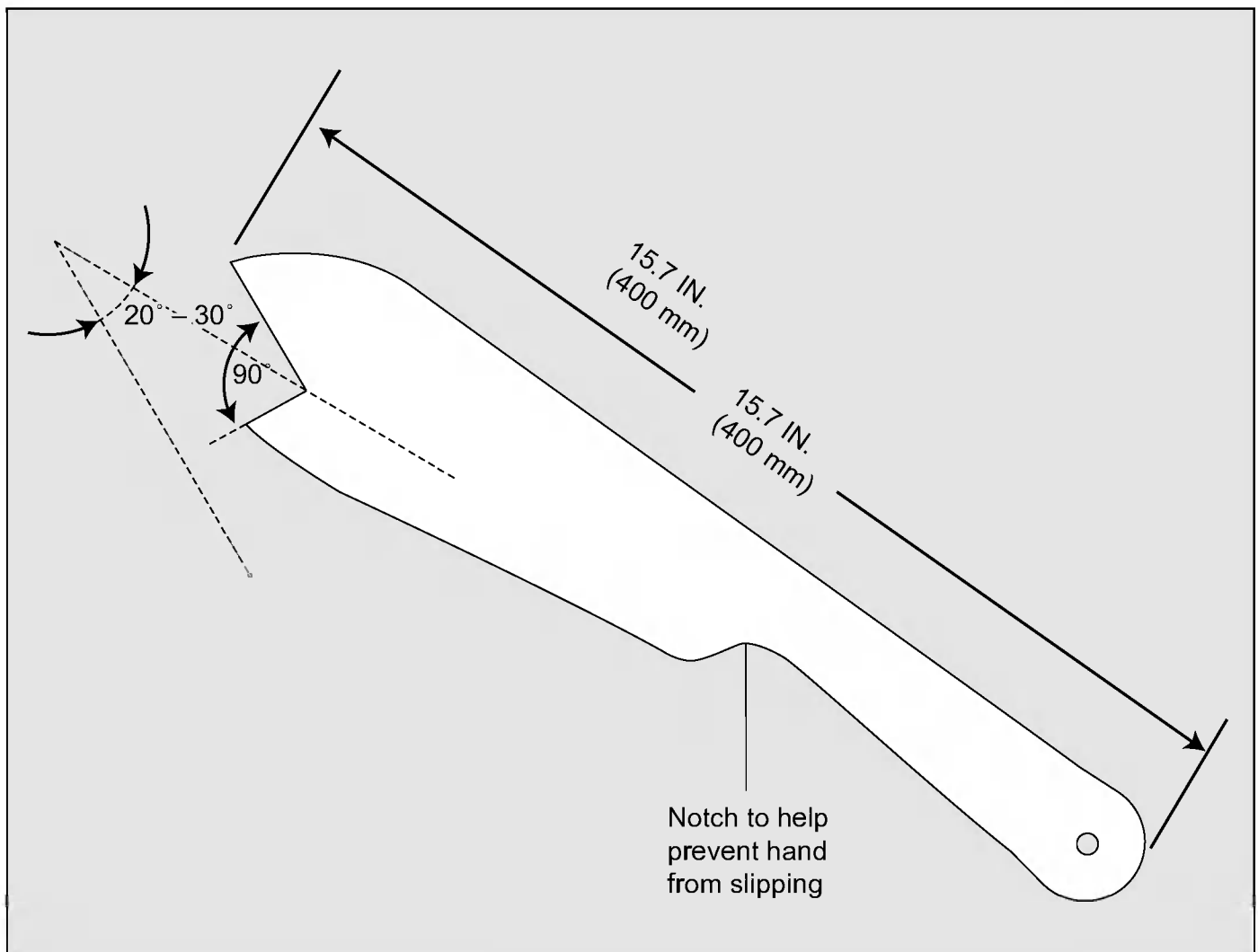

BEFORE OPERATING

HOW TO MAKE A FEATHERBOARD

- Select a solid piece of lumber approximately 3/4 in. thick, 2-1/2 in. wide and 12 in. long.
- Mark the center width on one end of stock. Miter width to 70° (see miter cut section for information on miter cuts).
- Set rip fence to allow approximately a 1/4 in. “finger” to be cut in the stock.
- Feed stock only to mark previously made at 6 in.
- Turn saw off and allow blade to completely stop rotating before removing stock.
- Reset rip fence (T) and cut spaced rips into workpiece to allow approximately 1/4 in. fingers and 1/8 in. spaces between fingers.

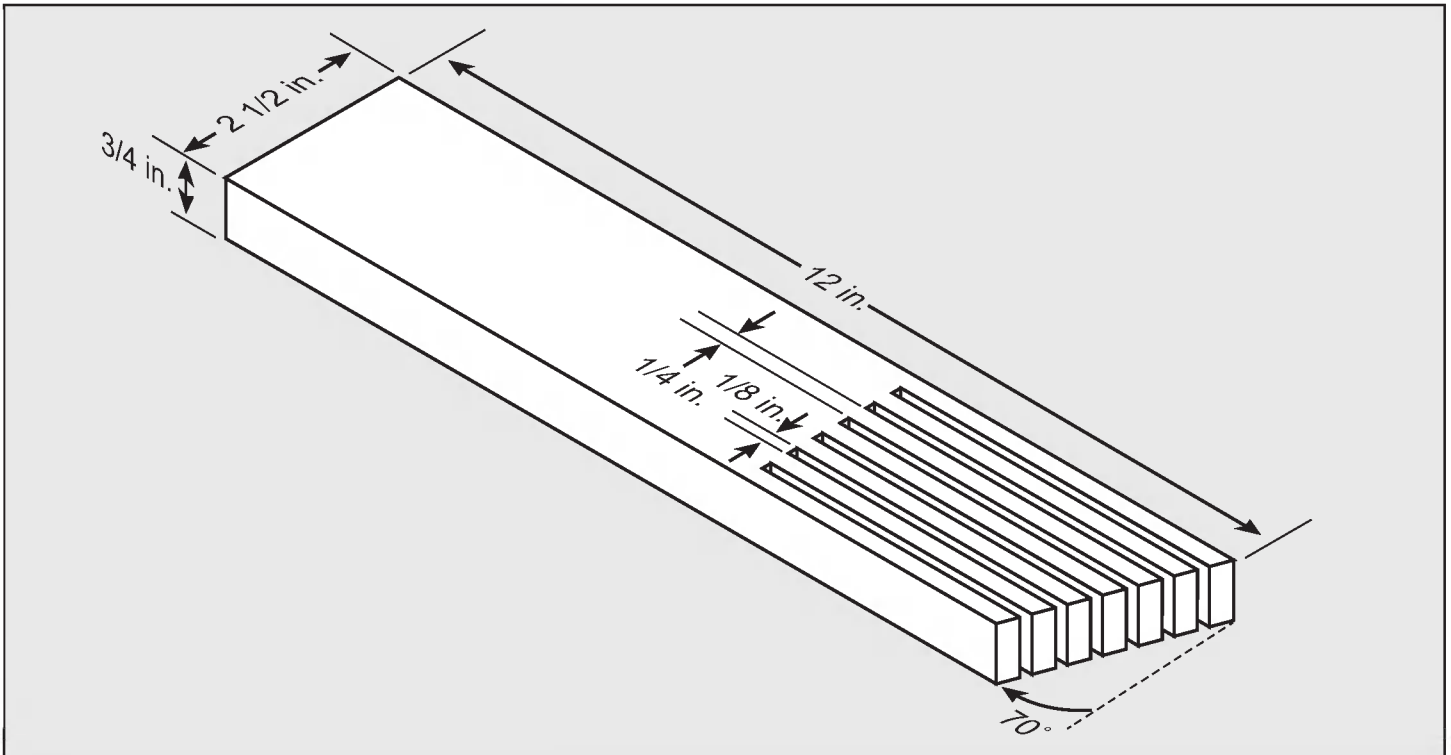

HOW TO MAKE A PUSH BLOCK

- Select a piece of wood about 4 in. wide, 6 in. long and 1 to 2 in. thick (a cutoff from a 2 by 4 makes a good blank for a push block).
- Drill a hole in the block and glue in a dowel to use as a handle (you can angle the hole to provide a more comfortable grip on the handle).
- To finish off the block, glue a piece of sandpaper or some kind of rubber material (old mouse pads work well) to the bottom of the block.

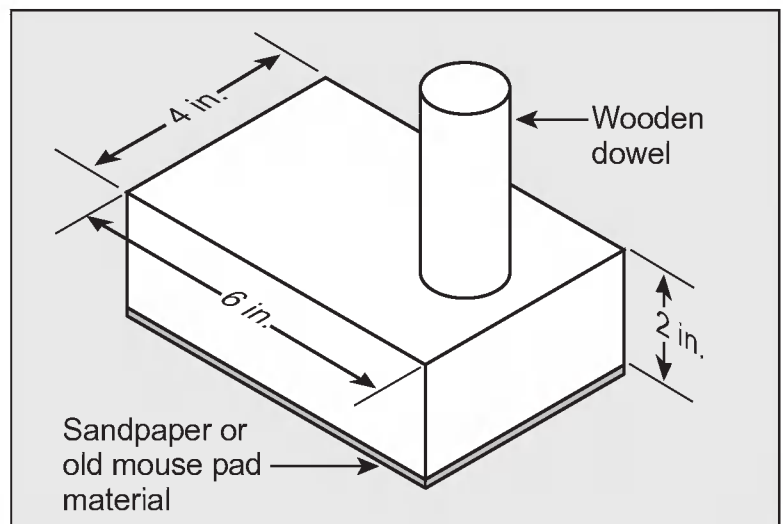

BEFORE OPERATING

HOW TO MAKE AN AUXILIARY FENCE

An auxiliary fence is a device used to close the gap between rip fence and saw table. **ALWAYS** use an auxiliary fence when ripping material 1/8 in. or thinner to prevent stock from slipping under fence.

- Select a piece of wood 3/4 in. thick, 2 3/8 in. wide and the width of the rip fence (19-3/4 in.).
- Drill a 1/4 in. hole, 1 in. from each end and 1-1/8 in. from bottom of rip fence.
- Drill a 1/4 in. hole in the middle rip fence 1/2 in. from bottom of auxiliary fence.
- Attach auxiliary fence to rip fence; place wood against rip fence and firmly on the saw table.
- From back side of rip fence, secure wood to fence using 1-3/4 in. wood screws.

Note: Make sure hardware does not protrude from front of auxiliary wood fence.

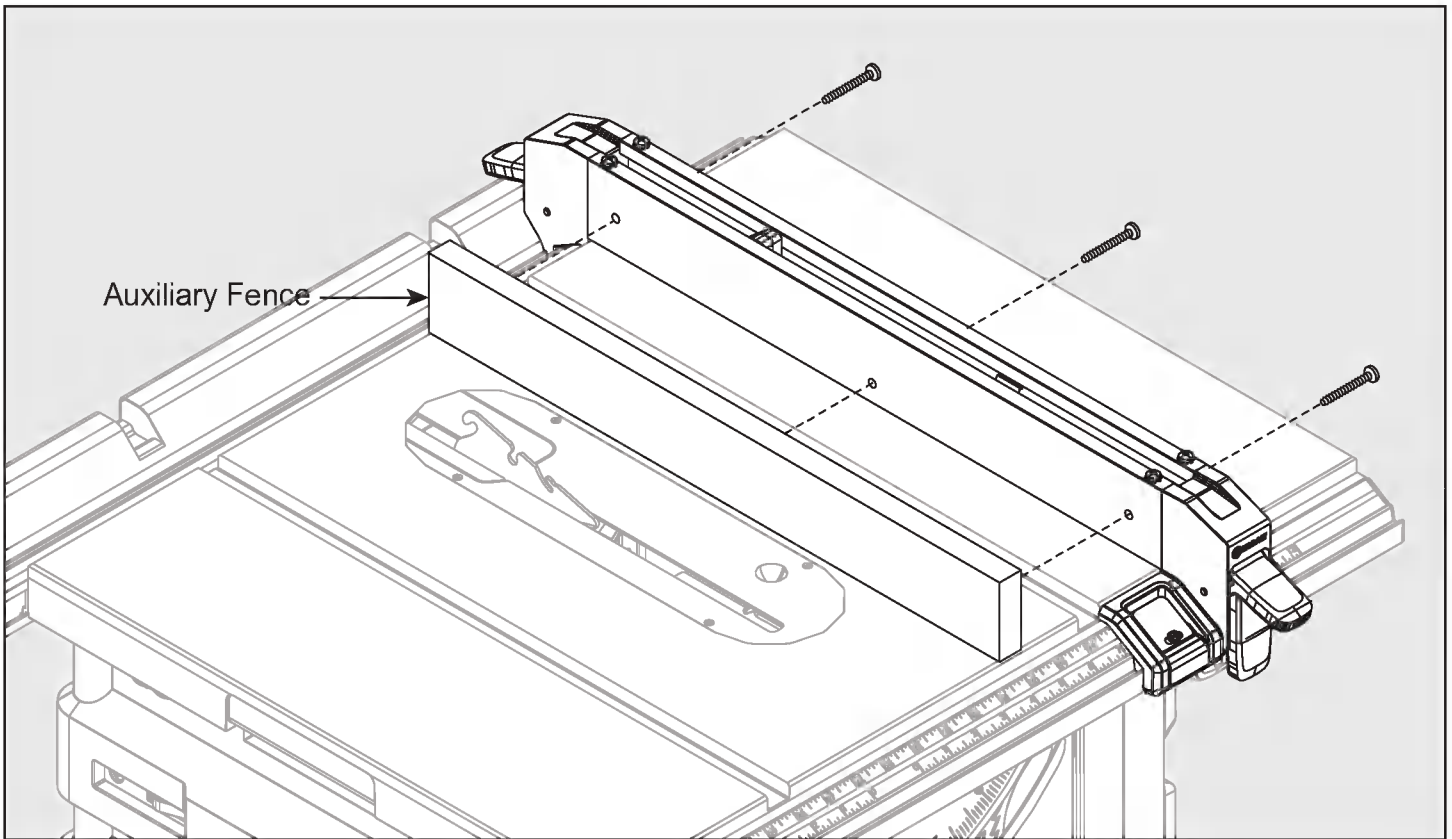

THROUGH CUTS WITH SINGLE BLADES



WARNING

- Always make sure the blade guard (A) and anti-kickback pawls (B) are in place and working properly when making these cuts to avoid possible injury.
- **DO NOT** use blades rated less than the speed of this tool. Failure to heed this warning could result in personal injury.
- To avoid kickback, make sure one side of the workpiece is securely against the rip fence during any rip cut, and hold the workpiece firmly against the miter gauge during any miter cut.
- **DO NOT** attempt compound miter cuts, with blade beveled and miter fence angled, until you are thoroughly familiar with the basic cuts and understand how to avoid kickback.



WARNING

- **DO NOT** use blades rated less than the speed of this tool.
- Failure to heed this warning could result in personal injury.
- Make sure blade guard (A) is installed and working properly to avoid serious possible injury.
- **DO NOT** attempt to make any cuts not covered here unless you are thoroughly familiar with the proper procedures and necessary accessories.
- Rip fence (T) must be on right side of blade (W) to avoid trapping wood and causing kickback. Placement of rip fence (T) to left of blade (W) will result in kickback and risk of serious personal injury.
- Using rip fence (T) as a cutoff gauge when cross cutting will result in kickback which can cause serious personal injury.
- **NEVER** make freehand cuts (cuts without miter gauge (U) or rip fence (T)). Unguided workpieces can result in serious injury.

CUTTING TIPS

- Knock out loose knots before making cut.
- Always provide proper support for wood as it comes out of saw.

MAKING CUTS

- Stand slightly to the side of blade path to reduce the chance of injury should kickback occur.
- Use miter gauge (U) when making cross, miter, bevel, and compound miter cuts. To secure angle, lock miter gauge (U) in place by twisting lock knob clockwise. **ALWAYS** tighten lock knob securely in place before use.

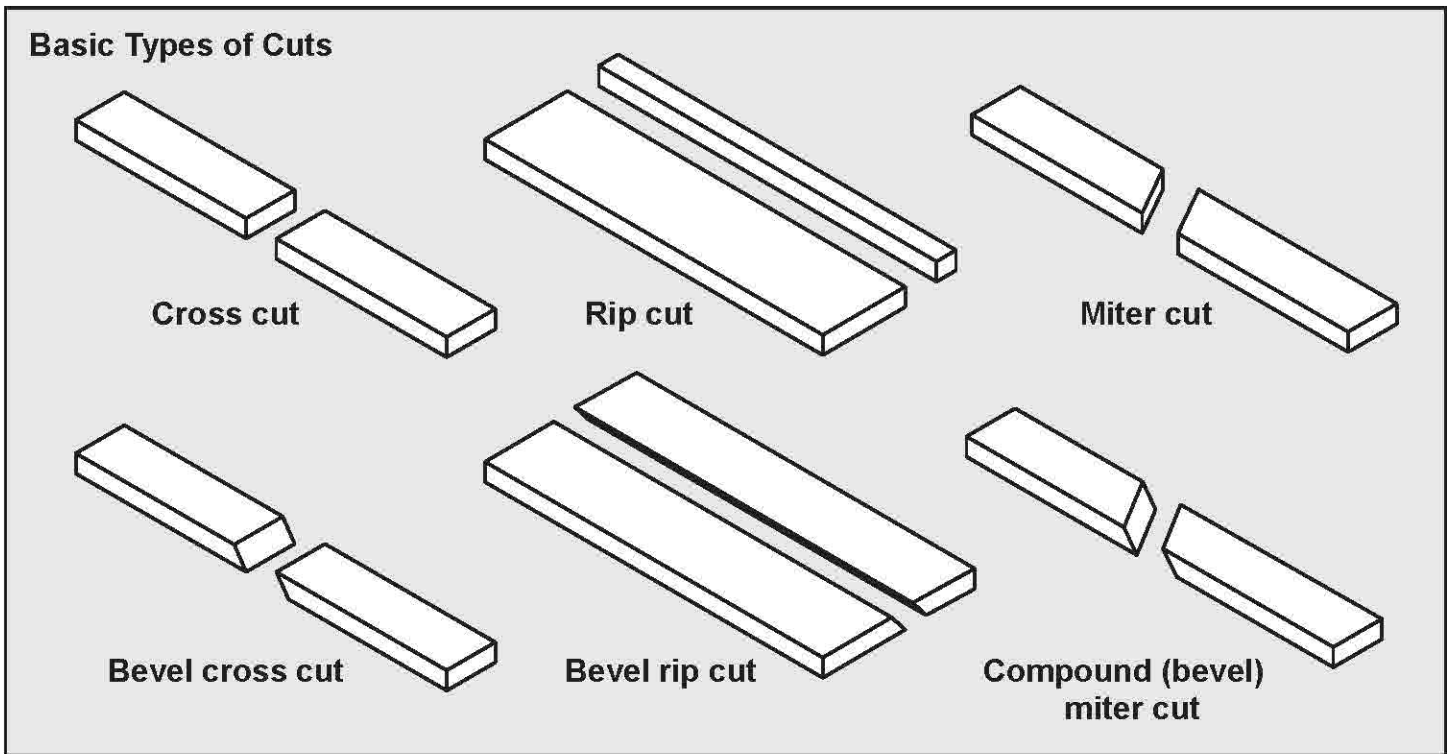

Note: All other cuts are combinations of these basic six. Operating procedures for making each kind of cut are given later in this section.

Making a Cross Cut

1. Remove rip fence (T).
2. Set blade (W) to correct depth for workpiece.
3. Set miter gauge (U) to 0° and tighten lock knob.
4. Make sure wood is clear of blade (W) before turning on saw.
5. To turn saw on, lift switch button.
6. Let blade (W) build up to full speed before moving workpiece into blade (W).
7. Hand closest to blade (W) should be placed on miter gauge (U) lock knob and hand farthest from blade (W) should be placed on workpiece. Feed workpiece into blade (W).
8. When cut is complete, turn saw off. Wait for blade (W) to come to a complete stop before removing workpiece.

Making a Rip Cut

1. Set blade (W) to correct depth for workpiece.
2. Position rip fence (T) at desired distance from blade (W) for cut and lock both ends securely.
3. Make sure wood is clear of blade (W) before turning on saw.
4. When ripping a long workpiece, place support same height as table (V) surface behind saw for cut work.
5. Turn saw on.
6. Position workpiece flat on table (V) with edge flush against rip fence (T). Let blade (W) build up to full speed before feeding workpiece into blade.

OPERATING INSTRUCTIONS

7. Once blade (W) has made contact with workpiece, use hand closest to rip fence (T) for guidance. Make sure edge of workpiece remains in solid contact with both rip fence (T) and surface of table (V). If ripping a narrow piece, use push stick (D) and/or push blocks to move piece through cut and past blade.
8. When cut is complete, turn saw off. Wait for blade (W) to come to a complete stop before removing workpiece.

Making a Miter Cut

1. Remove rip fence (T).
2. Set blade (W) to correct depth for workpiece.
3. Set miter gauge (U) to 0° and tighten lock knob.
4. Make sure the wood is clear of the blade (W) before turning on the saw.
5. Turn the saw on.
6. Let the blade (W) build up to full speed before moving the workpiece into the blade (W).
7. Hand closest to blade (W) should be placed on miter gauge (U) lock knob and hand farthest from blade (W) should be placed on workpiece. Feed workpiece into blade (W).
8. When cut is complete, turn saw off. Wait for blade (W) to come to a complete stop before removing workpiece.

Making a Bevel Cross Cut

1. Remove rip fence (T).
2. Unlock bevel locking lever.
3. Adjust bevel angle to desired setting.
4. Lock bevel locking lever.
5. Set blade (W) to correct depth for workpiece.
6. Set miter gauge (U) to 0° and tighten lock knob.
7. Make sure wood is clear of blade (W) before turning on saw.
8. Turn saw on.
9. Let blade (W) build up to full speed before moving workpiece into blade (W).
10. Hand closest to blade (W) should be placed on miter gauge (U) lock knob and hand farthest from blade (W) should be placed on workpiece. Feed workpiece into blade (W).
11. When cut is complete, turn saw off. Wait for blade (W) to come to a complete stop before removing workpiece.

Making a Bevel Rip Cut

1. Remove miter gauge (U).
2. Unlock bevel locking lever.
3. Adjust bevel angle to desired setting.
4. Lock bevel locking lever.
5. Set blade (W) to correct depth for workpiece.
6. Position rip fence (T) at desired distance from blade (W) for cut and securely lock handle.
7. Make sure wood is clear of blade before turning on saw.
8. When ripping a long workpiece, place support same height as table (V) surface behind saw for cut work.

OPERATING INSTRUCTIONS

9. Turn saw on.
10. Position workpiece flat on table (V) with edge flush against rip fence (T). Let blade build up to full speed before feeding workpiece into blade.
11. Once blade has made contact with workpiece, use hand closest to rip fence for guidance. Make sure edge of workpiece remains in solid contact with both rip fence and surface of table (V). If ripping a narrow piece, use push stick (D) to move piece through cut and past blade.
12. When cut is complete, turn the saw off. Wait for the blade to come to a complete stop before removing the workpiece.

Making a Compound (Bevel) Miter Cut

1. Remove rip fence (T).
2. Unlock bevel locking lever.
3. Adjust bevel angle to desired setting.
4. Lock bevel locking lever.
5. Set blade (W) to correct depth for workpiece.
6. Set miter gauge (U) to desired angle and tighten adjusting clamp knob.
7. Make sure wood is clear of blade (W) before turning on saw.
8. Turn saw on.
9. Let blade (W) build up to full speed before moving workpiece into blade (W).
10. Hand closest to blade should be placed on miter gauge lock knob and hand farthest from blade (W) should be placed on workpiece.
11. When cut is complete, turn saw off. Wait for blade (W) to come to a complete stop before removing workpiece.

Making a Large Panel Cut

1. Place a support the same height as top of saw table (V) behind saw for cut work. Add supports to sides as needed.
2. Depending on shape of panel, use rip fence (T) or miter gauge (U). If panel is too large to use either rip fence (T) or miter gauge (U), it is too large for this saw.
3. Make sure wood does not touch blade (W) before saw is turned on.
4. Turn saw on.
5. Position workpiece flat on table (V) with edge flush against rip fence. Let blade build up to full speed before feeding workpiece into blade (W).
6. Use push stick (D) to move piece through cut and past blade (W).
7. When cut is complete, turn saw off. Wait for blade (W) to come to a complete stop before removing workpiece.

DADOS AND OTHER NON-THROUGH CUTS

The use of a non-through cut is essential to cutting grooves, rabbets and dados. Non-through cuts can be made using a standard blade having a diameter of 10 inches or less, or a dado blade up to 13/16 inches wide with a diameter of 8 inches or less. Non-through cuts are the only type of cuts that should be made without the blade guard assembly installed. Make sure the blade guard assembly is reinstalled upon completion of this type of cut.

Making a Non-Through Cut



WARNING

- To reduce the risk of serious injury when making non-through cuts, follow all applicable warnings and instructions listed below in addition to those listed above for the relevant through cut.
- When making a non-through cut, blade (W) is covered by workpiece during most of cut. Be alert to exposed blade (W) at start and finish of every cut to avoid the risk of personal injury.
- Never feed wood with hands when making any non-through cuts such as rabbets or dados. To avoid personal injury, always use push blocks, push sticks, and/or featherboards.
- Read the appropriate section which describes the type of cut in addition to this section on non through or dado cuts. For example, if your non-through cut is a straight cross cut, read and understand the section on straight cross cuts before proceeding.
- Once all dado and non-through cuts are completed, unplug saw and reinstall riving knife (X) in raised position. Install anti-kickback pawls (B) and blade guard (A).
- Always use push blocks and or push sticks, and/or featherboards when making dado cuts to avoid the risk of serious injury.

1. Unplug saw.
2. Unlock release lever (O).
3. Adjust bevel angle to 0°.
4. Lock release lever (O).
5. Remove blade guard (A) and anti-kickback pawls (B).
6. Place riving knife (X) in “lowered” position.
7. Set blade (W) to correct depth for workpiece.
8. Depending on shape and size of wood, use either rip fence (T) or miter gauge (U).
9. Plug saw into power source and turn saw on.
10. Let blade (W) build up to full speed before moving workpiece into blade (W).
11. Always use push blocks, push sticks, and/or featherboards when making non-through cuts to reduce the risk of serious injury.
12. When cut is made, turn saw off. Wait for blade (W) to come to a complete stop before removing workpiece.

Making a Dado Cut

Dado blades are stacked blades that can be used when making through cut slots in a workpiece, or the non-through cuts described above. Dado blades require a special throat plate. Dado blades and throat plates are all sold separately.



WARNING

Before performing any adjustment, make sure tool is unplugged from power supply and switch is in off position. Failure to do so could result in serious personal injury.

The table saw has been adjusted at the factory for making very accurate cuts. However, some components might have been jarred out of alignment during shipping. Also, over a period of time, readjustment will probably become necessary due to wear.

Carefully check alignment with a framing square before beginning adjustments to confirm whether they are necessary. Use test cuts after completing adjustments to avoid damaging workpiece.

To place riving knife in lowered position (for non-through cuts):

Note: Remove throat plate (Y).

1. Raise the blade (W) by turning the height adjusting wheel (P) clockwise.
2. Unscrew riving knife lock knob with fingers. Then push in on loosened knob to release riving knife. Push the riving knife (X) down until it is below the blade (W). Tighten riving knife lock knob with fingers. Reinstall throat plate (Y).

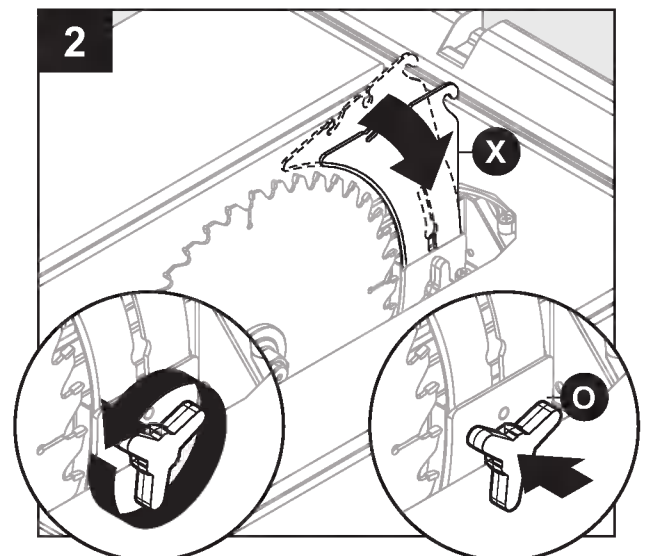
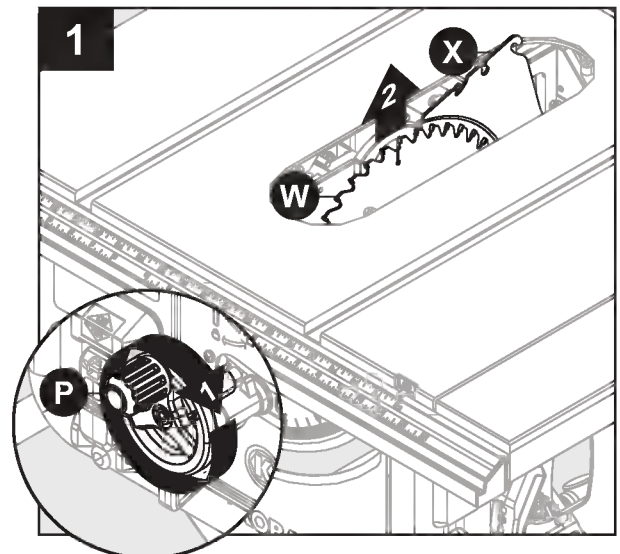

ADJUSTMENTS

CHECKING AND ALIGNING RIVING KNIFE AND SAW BLADE

See Assembly Instructions, page 21.

REPLACING BLADE

Note: Turn power off and unplug saw. Set bevel setting to "0". Remove blade guard (A), anti-kickback pawls (B) and throat plate (Y). Raise saw blade (W).

1. Make sure release lever (O) is locked. Insert open end wrench (G) onto flats on arbor shaft. Insert closed end wrench (F) over blade nut.

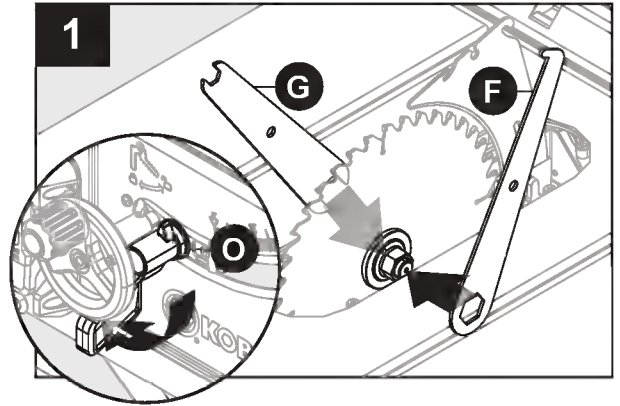

2. Holding both wrenches firmly, pull closed end wrench (F) forward while pushing open end wrench (G) to back of saw.

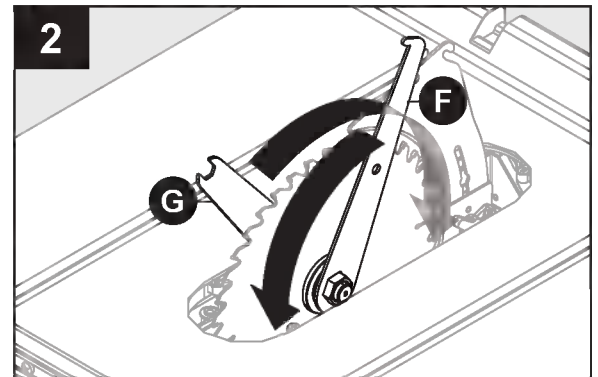

3. Remove nut, washer and blade (W).
4. Place new blade on arbor shaft (teeth must point down toward front of saw to work properly).
5. Place blade washer and blade nut over arbor shaft. Be sure dome side of blade washer faces out from blade and all items are snug against arbor housing. Make sure blade nut is securely tightened. **DO NOT** over tighten.
6. Rotate blade by hand to make sure it turns freely.
7. Lower saw blade and reinstall throat plate (Y).

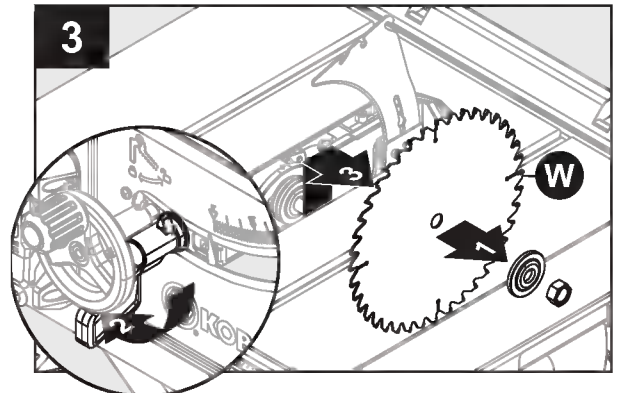

Note: To replace blade (W) with an accessory blade, follow instructions provided with accessory.

ADJUSTMENTS

RIVING KNIFE AND SAW BLADE ALIGNMENT

Blade and riving knife alignment is set at factory and in most cases will not need to be adjusted. However, the alignment should always be checked after installing blade or riving knife, and can be adjusted if necessary. If riving knife (X) is out of alignment with blade (W), adjustment is needed. Riving knife (X) must be in alignment front to back (horizontally) and top to bottom (vertically).

Note: Unplug saw. With bevel adjustment assembly in vertical (0 degree) position, raise blade (W) by turning height/bevel adjusting wheel (P) clockwise. Remove anti-kickback pawls (B) and blade guard (A).

To check/adjust (horizontally):

1. Place framing square (or straight edge) against both blade (W) and riving knife (X). Blade (W) and riving knife (X) are aligned if framing square contacts both blade (W) and riving knife (X) evenly with no gaps.

Note: Place framing square between carbide teeth and measure from blade. This step will ensure framing square is square against blade from front to back of blade.

2. If blade and riving knife are not aligned, using hex head wrench, slowly turn top two set screws (located below and to either side of riving knife lock knob) until the riving knife (X) is aligned with the blade (W).

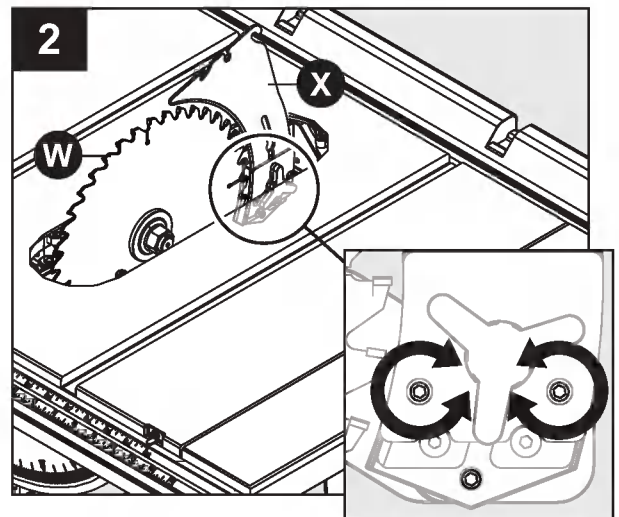
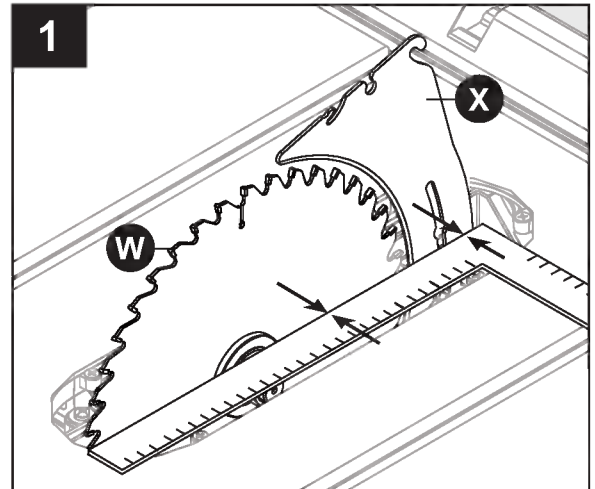

ADJUSTMENTS

To check/adjust (vertically):

1. Place framing square on table and against both blade (W) and riving knife (X). Blade (W) and riving knife (X) are aligned if framing square contacts both blade (W) and riving knife (X) evenly with no gaps.

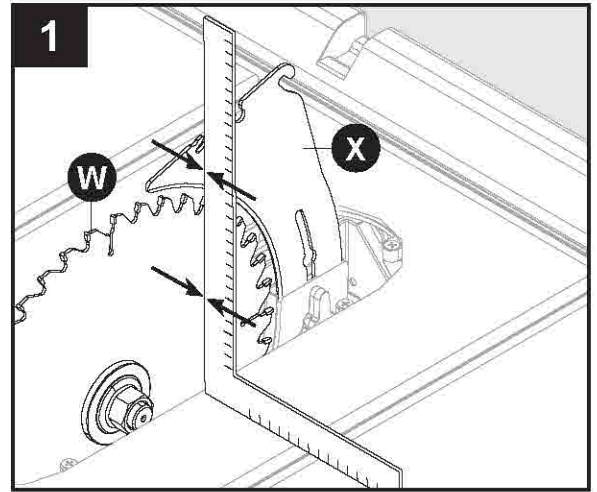

2. If blade and riving knife are not aligned, using hex head wrench, slowly turn the bottom set screw (located below riving knife lock knob) until the riving knife (X) is aligned with the blade (W).

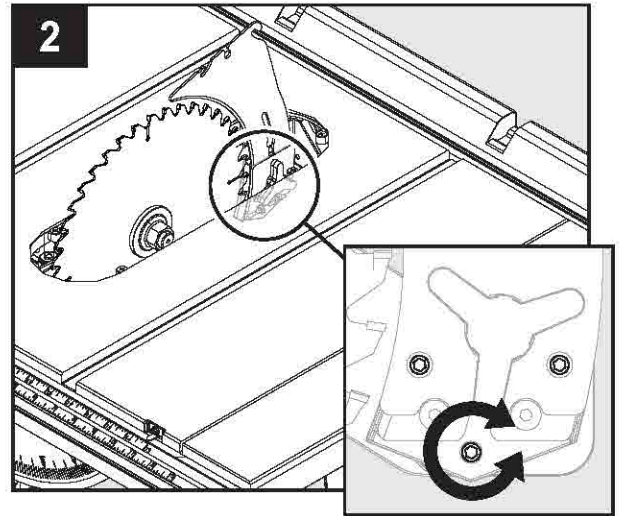

ADJUSTMENTS

HEELING (PARALLELING) BLADE TO MITER GAUGE GROOVE



WARNING

- Blade (W) must be parallel to miter gauge groove so that wood does not bind, resulting in kickback. Failure to do so could result in serious personal injury.
- To reduce risk of injury from kickback, align rip fence (T) to blade (W) following any blade adjustments.

DO NOT loosen any screws for this adjustment until alignment has been checked with a square to be sure adjustments are necessary. Once screws are loosened, items **must** be reset.

Note: Unplug saw. Remove blade guard (A) and anti-kickback pawls (B). Raise the blade (W) by turning height adjusting wheel (P).

1. Mark beside one of blade teeth at front of blade (W). Place a combination square even with front of saw table (V) and side of saw blade (W) as shown.

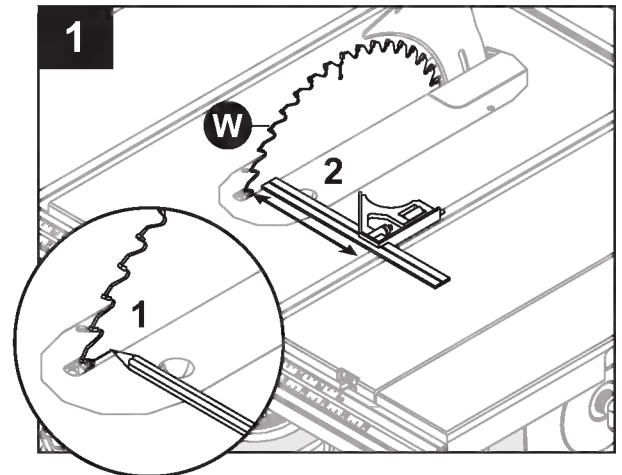

2. Turn blade (W) so that marked tooth is at back. Move combination square to the rear and again measure the distance. If the distances are the same, blade (W) is square.

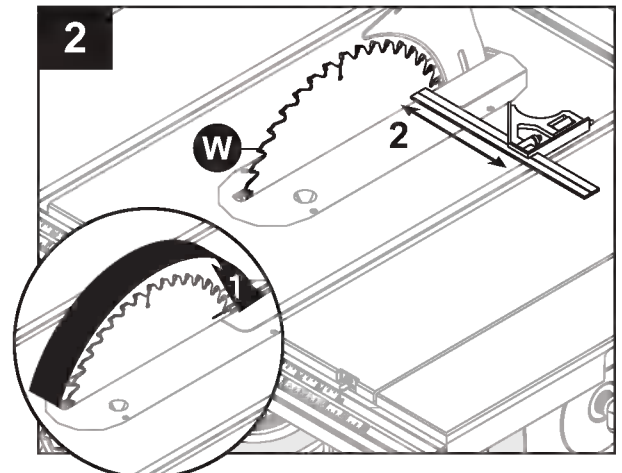

ADJUSTMENTS

If the distances are different:

3. From underneath the table top, loosen trunnion securing bolts with a hex wrench.

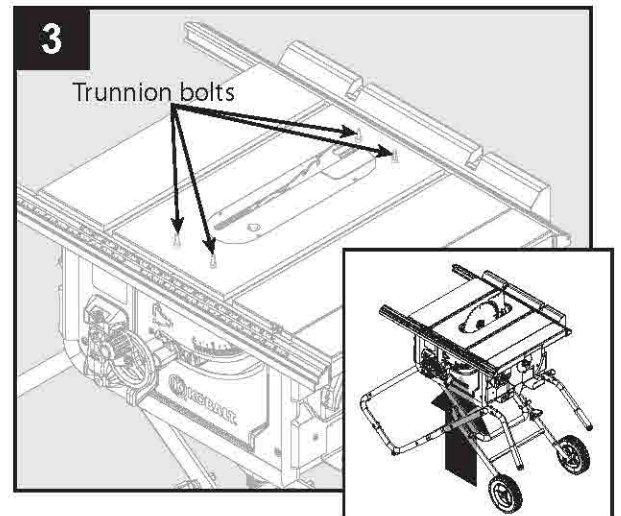

4. If back of blade (W) was too close to combination square, place a block of wood on right side of blade (W) tap with a small hammer to align to square.
5. Retighten the trunnion bolts with hex wrench. Recheck alignment after bolts are retightened.

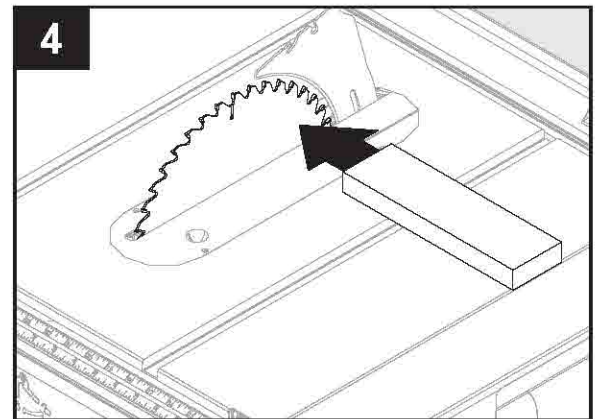

BEVEL ADJUSTMENT

Angle settings of saw have been set at the factory and, unless damaged in shipping, should not require setting during assembly. After extensive use, they may need to be checked.

To check 0° bevel:

1. Turn power off and unplug saw.
2. Raise blade (W) and blade guard (A).
3. Loosen release lever (O) and slide to 0° position.
4. Place a combination square beside blade (W) and check.
5. If blade is out of square, loosen cam and adjust to exactly at 0°.
6. Retighten cam.

To check 45°:

1. Turn power off and unplug saw.
2. Raise blade (W) and blade guard (A).
3. Loosen release lever (O) and slide to 45° position.
4. Place a combination square beside blade (W) and check.
5. If blade is out of square, loosen cam and adjust to exactly 45°.
6. Retighten cam.

Note: For ease of use, bevel adjust should stop at 45° and 90°.

ADJUSTMENTS

ADJUSTING BEVEL INDICATOR

• Adjust bevel indicator if it is not at zero when the blade is perpendicular to the table.

1. With blade perpendicular to table, loosen screw.
2. Set indicator to 0° on bevel scale.
3. Retighten screw.

CHECKING ALIGNMENT OF RIP FENCE TO MITER SLOT

1. Turn power off.
2. Unplug saw.
3. Raise locking levers to permit rip fence (T) to be moved.
4. Move fence so until it aligns with miter slot.
5. Lower locking levers.
6. Make two or three test cuts on scrap wood. If cuts are not true, repeat process.

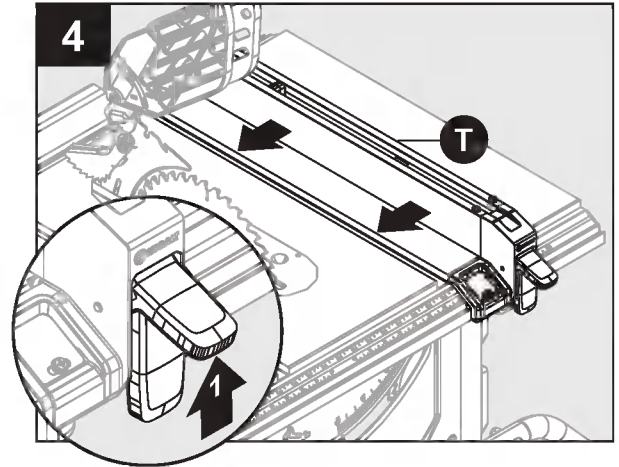

ACCESSORY STORAGE

• Accessories can be stored in positions shown below.

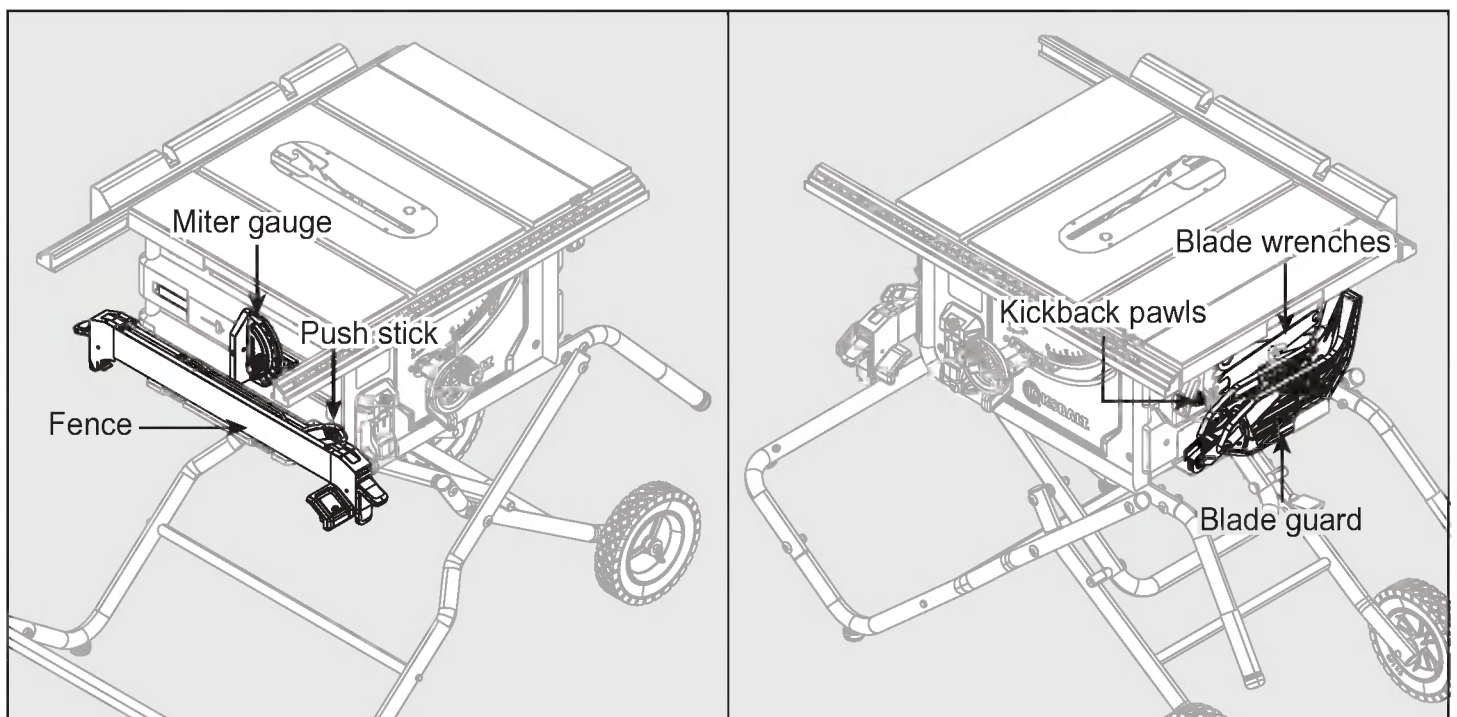



WARNING

- When servicing, use only identical replacement parts. Use of any other parts may create a risk of personal injury or cause product damage.
- Before performing any maintenance, make sure the tool is unplugged from the power supply and the switch is in the off position.
- **DO NOT** at any time let brake fluids, gasoline, petroleum-based products, penetrating oils, etc., come in contact with plastic parts. Chemicals can damage, weaken, or destroy plastic.

GENERAL MAINTENANCE

- Avoid using solvents when cleaning plastic parts. Most plastics are susceptible to damage from various types of commercial solvents and may be damaged by their use. Use clean cloths to remove dirt, dust, oil, grease, etc.
- Periodically check all clamps, nuts, bolts, and screws for tightness and condition. Make sure the throat plate is in good condition and level with the table.
- Check the blade guard assembly after performing maintenance to make sure it is installed correctly and functioning properly.
- **Clean plastic parts only with a soft damp cloth. DO NOT** use any aerosol or petroleum solvents.

LUBRICATION

- All of the bearings in this tool are lubricated with a sufficient amount of high grade lubricant for the life of the unit under normal operating conditions. Therefore, no further lubrication is required.

TROUBLESHOOTING

PROBLEM	POSSIBLE CAUSE	CORRECTIVE ACTION
Excess vibration.	<ol style="list-style-type: none"> 1. Blade is out of balance. 2. Blade is damaged. 3. Legs are not properly attached to saw. 4. Work surface is uneven. 5. Blade is warped. 	<ol style="list-style-type: none"> 1. Replace blade. 2. Replace blade. 3. Tighten all hardware. 4. Reposition on flat surface. Adjust legs of leg stand. 5. Check saw blade installation. Replace blade if necessary.
Rip fence does not move smoothly.	<ol style="list-style-type: none"> 1. Rip fence not mounted correctly. 2. Rails are dirty or sticky. 	<ol style="list-style-type: none"> 1. Remount the rip fence. 2. Clean and wax rails.
Cutting binds or burns work.	<ol style="list-style-type: none"> 1. Blade is dull. 2. Work is fed too fast. 3. Wood is warped. 4. Rip fence is misaligned. 5. Riving knife is out of alignment. 	<ol style="list-style-type: none"> 1. Replace or sharpen blade. 2. Slow the feed rate. 3. Replace the wood. 4. Check and adjust the rip fence. Align the rip fence. 5. See Checking and Aligning Riving Knife and Saw Blade, page 41.
Wood edges away from rip fence when ripping.	<ol style="list-style-type: none"> 1. Blade not properly sharpened or set. 	<ol style="list-style-type: none"> 1. Re-sharpen or replace dull blade.
Saw does not make accurate 90° or 45° cuts.	<ol style="list-style-type: none"> 1. Positive stops inside cabinet need adjusting (Bevel Cuts). 2. Miter gauge is misaligned (Miter Cuts). 	<ol style="list-style-type: none"> 1. Adjust positive stops. 2. Adjust the miter gauge.
Height adjust wheel is hard to turn.	<ol style="list-style-type: none"> 1. Gears or screw post inside cabinet are clogged with saw dust. 	<ol style="list-style-type: none"> 1. Clean the gears.
Saw does not start.	<ol style="list-style-type: none"> 1. Power cord or wall cord is not plugged in. 2. Circuit fuse is blown. Circuit breaker is tripped. 3. Cord or switch is damaged. 	<ol style="list-style-type: none"> 1. Plug in power cord or wall cord. 2. Replace circuit fuse. Reset circuit breaker. 3. Have the cord or switch replaced at your nearest authorized service center.
Blade makes poor cuts.	<ol style="list-style-type: none"> 1. Blade is dull or dirty. 2. Blade is wrong type for cut being made. 3. Blade is mounted backwards. 	<ol style="list-style-type: none"> 1. Clean, sharpen, or replace blade. 2. Replace with correct type. 3. Remount blade.
Motor labors in rip cut.	<ol style="list-style-type: none"> 1. Blade not proper for rip cut. 	<ol style="list-style-type: none"> 1. Change blade; rip blade typically has fewer teeth.

THREE YEAR LIMITED WARRANTY

The Manufacturer will repair any product or component which under normal usage is proven to be defective in workmanship or material for a period of THREE (3) years from the date of initial retail purchase. This warranty is valid only to the original retail purchaser, as evidenced by the purchaser's original receipt or such other proof of purchase as Manufacturer may accept. This warranty is not transferable and does not cover any parts that have been subjected to misuse, abuse, alteration, overload, or accident, or damage caused by normal wear of moving parts.

Warranty replacement parts can be obtained by contacting Manufacturer at 1-888-3KOBALT. Only Manufacturer and its authorized agents are authorized to perform warranty service on this product. This warranty does not apply to accessories or damage caused where repairs have been made or attempted by others.

Manufacturer is not responsible for direct, indirect, incidental or consequential damages. Some states do not allow limitations on how long an implied warranty lasts and/or do not allow the exclusion or limitation of incidental damages, so the above limitations may not apply to you. This warranty gives you specific legal rights, and you may also have other rights, which vary from state to state.

Manufacturer makes no warranties, representations or promises as to the quality of its power tools other than those specially stated in this warranty.

For questions or warranty claims, call our customer service department at 1-888-3KOBALT (1-888-356-2258).

REPLACEMENT PARTS LIST

For replacement parts, call our customer service department at 1-888-3KOBALT, 8 a.m. - 8 p.m., EST, Monday - Friday.

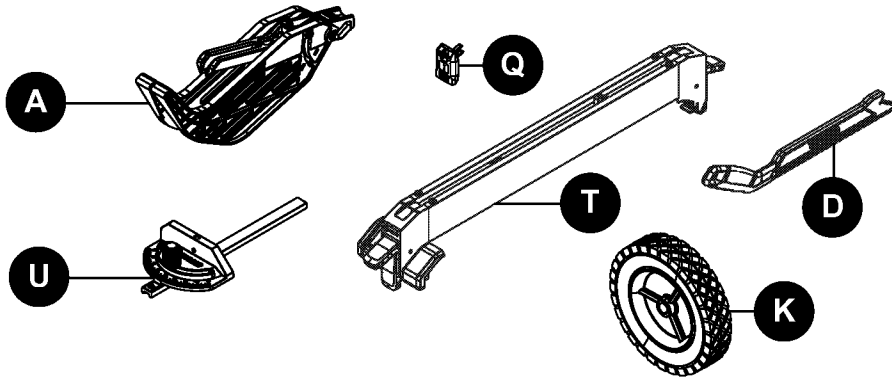

PART	DESCRIPTION	PART #
A	Blade guard	101501
Q	Key for off/on switch	101502
U	Miter gauge	101503
T	Rip fence	101504
D	Push stick	101505
K	Wheel	101506

Printed in Taiwan

KOBALT® and the K Design® are registered trademarks of LF, LLC. All Rights Reserved.