

# TDT-1201 MINI TRENCHER



Video on Youtube



Service information,  
Customer Support (888)680-2849,  
[inquiry@bilthardusa.com](mailto:inquiry@bilthardusa.com)

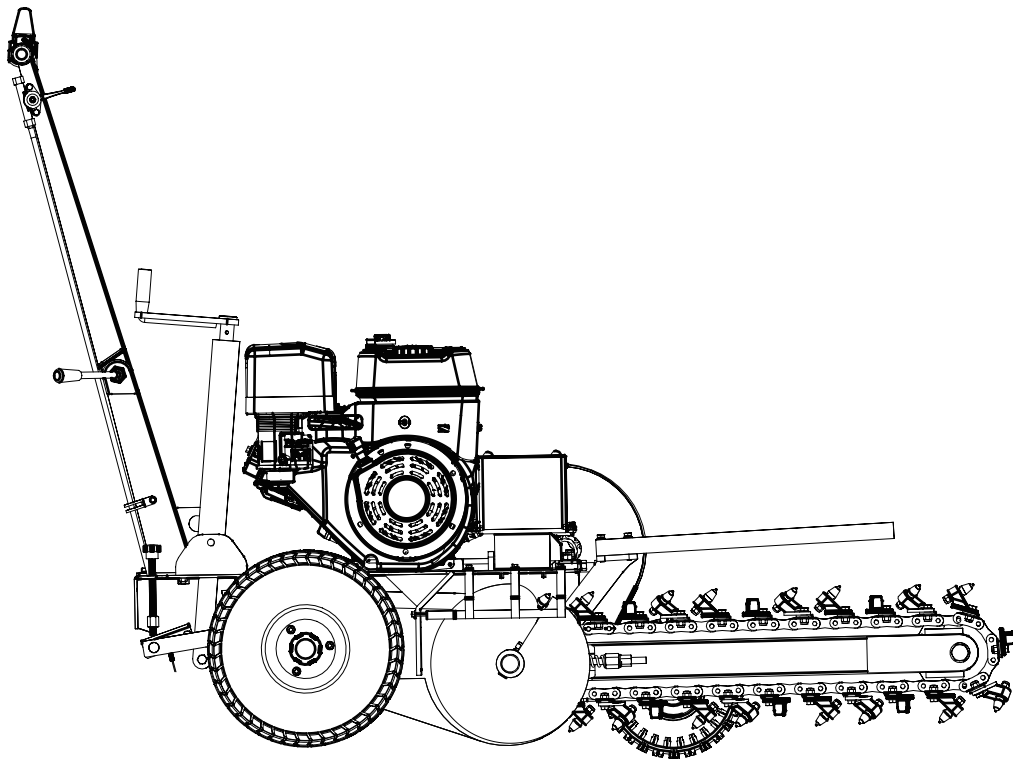

## Operator's Manual

***BILT HARD***

# ***BILT HARD***

## **WARNING**

---

- ▲ Any changes by the operators or dealers at their own are forbidden.
  - ▲ Any other purposes except **MINI TRENCHER** are not allowed.
  - ▲ Please read the owner's manual carefully and make sure you understand the instructions before using the machine.
  - ▲ Any damages or injuries caused by disobeying the above terms, our company will be free from any responsibilities and warranty services for this machine will be terminated accordingly.
-

---

## INTRODUCTION

---

There's a unique pride that comes with improving your own property. That moment you step back, wipe the sweat from your brow, and see a landscape transformed by your own two hands is incredibly rewarding. Whether you're installing a new sprinkler system, building a French drain to handle heavy rain, or laying down conduit for outdoor lighting, these projects elevate your home's function and beauty. But let's be honest: the initial excitement can quickly fade when you're facing the prospect of digging a long, deep trench with a shovel. That's back-breaking, weekend-stealing work. For any serious digging project, the right tool doesn't just make the job easier—it makes it possible. Today, we're diving into the world of trenchers and how to choose the perfect one for your DIY mission. This is the kind of machine that moves you from a hopeful DIYer to a landscape pro. The 15HP engine is your guarantee of power, plowing through tough soil that would have you hacking away with a pickaxe for hours. The electric start means you begin your project with a smile, not a struggle. And the 24-inch max depth means you can confidently take on almost any residential digging task, from simple sprinkler lines to serious yard drainage solutions.

---

## TABLE OF CONTENTS

---

|  |           |
|--|-----------|
| <b>TABLE OF CONTENTS.....</b>                  | <b>1</b>  |
| <b>SPECIFICATIONS.....</b>                     | <b>2</b>  |
| <b>OVERALL DIMENSIONS.....</b>                 | <b>3</b>  |
| <b>SAFETY SIGNS.....</b>                       | <b>3</b>  |
| <b>SAFETY.....</b>                             | <b>4</b>  |
| <b>UNPACKING THE CONTAINER.....</b>            | <b>8</b>  |
| <b>CONTENTS SUPPLIED.....</b>                  | <b>8</b>  |
| <b>ASSEMBLY.....</b>                           | <b>10</b> |
| <b>OPERATION.....</b>                          | <b>13</b> |
| <b>MAINTENANCE.....</b>                        | <b>17</b> |
| <b>EXPLOSION VIEW AND SPARE PART LIST.....</b> | <b>20</b> |

**SPECIFICATIONS**

| <b>Model</b>             | <b>TDT-1201</b>   |
|--------------------------|---|
| <b>Engine</b>            | <b>DUCAR DH420 15HP</b>                                 |
| <b>Engine Type</b>       | <b>ELECTRIC START AIR COOLED 4 STROKE PETROL ENGINE</b> |
| <b>Displacement/ HP</b>  | <b>15hp;420cc</b>                                       |
| <b>Start</b>             | <b>Recoil/E-Start; 12V 14Ah Lead-acid battery</b>       |
| <b>Belt</b>              | <b>2x V-Belts</b>                                       |
| <b>Clutch</b>            | <b>Centrifugal Clutch</b>                               |
| <b>Carbide Tip</b>       | <b>27 x Carbide Alloy High-Pressure Teeth</b>           |
| <b>Scraper</b>           | <b>9 Pcs</b>  |
| <b>Chain Length</b>      | <b>81.5 in</b>  |
| <b>Chain Speed</b>       | <b>1805ft / min</b>                                     |
| <b>Max. Trench Depth</b> | <b>24 in</b>  |
| <b>Max. Trench Width</b> | <b>4 in</b>   |
| <b>Wheelbase</b>         | <b>29 in</b>  |
| <b>Tire</b>              | <b>15 x 6-6 /4.1-4 Tubeless Tire</b>                    |
| <b>Assembled Weight</b>  | <b>419 lbs</b>  |
| <b>Gross Weight</b>      | <b>441 lbs</b>  |
| <b>Packing Size</b>      | <b>45.6x 30.1 x 33.4 in</b>                             |
| <b>Machine Warranty</b>  | <b>1 Year</b>   |
| <b>Engine Warranty</b>   | <b>1 Years</b>  |

## OVERALL DIMENSIONS

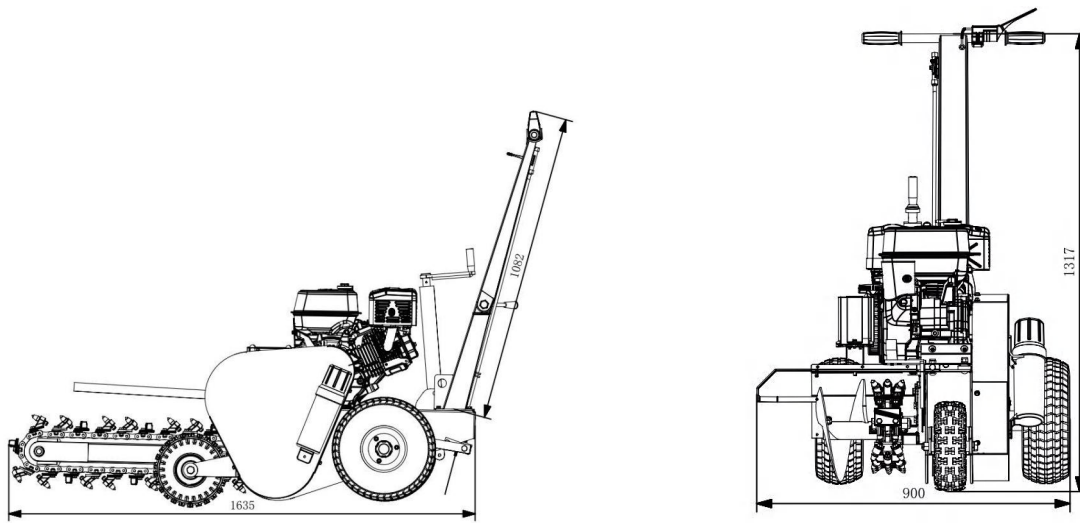

## SAFETY SIGNS

The rating plate on your machine may show symbols. These represent important information about the product or instructions on its use.

# TRENCHER

### WARNING AND SAFETY INSTRUCTIONS

#### OPERATOR SAFETY

- Always wear the proper clothing and protective gear. Eye and ear protection, hard hat, boots, gloves and dust masks are that may be required.
- Keep hair, fingers, and all other body parts away from openings and moving parts. Always wear long pants, boots, and gloves. Secure hair so it is above shoulder length.
- Do not operate trencher indoors. outdoor use only.
- Do not operate trencher when tired, ill, or under the influence of alcohol, drugs, or medication.
- Always assume the digging location contains underground utilities. Contact appropriate utility company to determine where electrical cables, gas lines, water lines, etc. are buried before operation.
- Always use extreme caution while operating tool. Be sure of your footing and physical capabilities.

#### TOOL SAFETY

- Inspect entire trencher before each use. Replace damaged or worn parts.
- Check for fuel leaks and make sure all fasteners are in place and securely fastened.
- Replace digging blades that are severely worn. Be sure the digging chain and engine is not moving.

#### MAINTENANCE SAFETY

- Maintain according to recommended procedures included in this manual.
- Disconnect the spark plug wire before performing maintenance.
- Stop engine before removing fuel cap.
- Use only genuine replacement parts of the engine manufacturer.

#### FUEL SAFETY

- Refuel outdoors and where no sparks and flames.
- Store fuel in a container approved for gasoline.
- Do not smoke or allow smoking near fuel or the trencher or while using the trencher.
- Clean up all fuel spills before starting engine.
- Move at least 10 feet away from fueling site before starting engine.
- Stop engine before removing fuel cap.

#### DIGGING SAFETY

- Be sure that the area is clear of potential hazards, such as pipes, rocks or other materials that could possibly entangle itself around the digging chain or cause unstable footing before using the trencher.
- Keep others bystanders and helpers outside a 15 foot hazard zone from the trencher.
- Hold the trencher handle firmly with both hands.
- Keep all your body and clothing away from the digging chain, auger and other moving parts.
- Inspect the digging site. Soil, job specifications and operator experience may dictate that a different trencher or method be used to do the job.
- Do not leave trenches open or unmarked.

#### TRANSPORTATION AND STORING

- Always shut off the fuel valve and engine.
- Always allow the engine to cool.
- Store trencher and fuel where fuel vapors cannot reach sources of combustion like, water heaters, electric motors, switches, furnaces, etc.
- Always secure this trencher with tie downs or similar restraints when transporting.
- The trencher shall be stored in a manner that prevents it from falling, rolling or tipping over.



---

## SAFETY

---

### Operator Preparation

Thoroughly read and understand the operator's manual and all labels on the machine. Familiarize yourself with its applications, limitations, and all potential hazards specific to it. Ensure you are completely familiar with all controls and their proper operation, including how to stop the machine and disengage controls quickly. Before operation, you must read and understand all instructions and safety precautions in the separately provided Engine Manufacturer's Manual. Do not attempt to start or operate the machine until you fully understand the proper procedures for operating and maintaining the engine to prevent accidental injury or property damage.

### Personal Safety

Do not operate the machine while under the influence of drugs, alcohol, or any medication that could impair your ability. Dress appropriately by wearing heavy long pants, boots, and gloves. Do not wear loose clothing, short pants, or jewelry of any kind. Secure long hair above shoulder level. Keep hair, clothing, and gloves away from moving parts, as they can become entangled. Always use appropriate safety equipment, including eye protection. Equipment such as dust masks, hard hats, or hearing protection, when used for suitable conditions, reduces personal injuries.

### Work Area Safety

Never start or run the machine inside a closed area. Engine exhaust fumes contain carbon monoxide, a deadly, odorless gas. Operate the unit only in a well-ventilated outdoor area. Do not operate the machine without good visibility or lighting. Maintain proper footing and balance at all times to ensure better control of the machine in unexpected situations. Do not overreach. Operate the machine only while wearing protective footwear that protects your feet and improves traction on slippery surfaces; never operate it barefoot or in sandals.

### Machine Inspection and Condition

#### Machine Inspection and Condition

Inspect your machine before starting it. Ensure all guards are in place and in good working order. Check that all nuts, bolts, etc.,

are securely tightened. Never operate a machine that requires repair or is in poor mechanical condition. Check for fuel leaks and replace any damaged, missing, or failed parts before use. Keep the machine in a safe working condition at all times.

### Safety Devices and Control

Never remove or tamper with any safety devices. Check their proper operation regularly. Do not use the machine if the engine switch fails to turn the engine on or off. Any gasoline-powered machine that cannot be controlled with its switch is dangerous and must be repaired. Form a habit of checking that keys and adjusting wrenches are removed from the machine before starting it. A wrench or key left attached to a rotating part can cause personal injury.

### Operational Awareness

Stay alert and watch what you are doing at all times. Use common sense when operating the machine. To avoid accidental starting, ensure the engine is off before transporting the machine or performing any maintenance or service. Transporting or servicing a machine with the engine running invites accidents.

#### FUEL SAFETY

### General Hazard

Fuel is highly flammable, and its vapors can explode if ignited. Always observe precautions during use to minimize the risk of serious personal injury.

### Refueling Precautions

Always refuel or drain the fuel tank in a clean, well-ventilated outdoor area using an approved fuel storage container. Never smoke, and keep away from all sparks, open flames, or other ignition sources during refueling or operation. To prevent sparking or arcing, keep grounded conductive objects such as tools away from exposed, live electrical parts and connections, as these could ignite fuel vapors.

## Safe Refueling Procedure

Always shut off the engine and allow it to cool completely before refueling. Never remove the fuel tank cap or add fuel while the engine is running or hot. Do not operate the machine if any leaks are present in the fuel system. Slowly loosen the fuel tank cap to relieve any internal pressure. Never overfill the tank; fill to no more than 12.5 mm (1/2 inch) below the filler neck to allow for fuel expansion due to engine heat.

## Handling Spills and Storage

Securely replace all fuel tank and container caps after refueling. Immediately wipe up any spilled fuel. Never operate the unit without the fuel cap securely in place. If a fuel spill occurs, do not start the engine. Move the machine away from the spill and avoid creating any ignition source until the vapors have completely dissipated. Store fuel only in specifically designed and approved containers, placed in a cool, well-ventilated area away from sparks, open flames, or other ignition sources.

## Machine Storage

Never store fuel or a machine with fuel in its tank inside a building where fumes could reach an ignition source, such as a water heater, furnace, or clothes dryer. Always allow the engine to cool completely before storing the machine in any enclosure.

# MACHINE USE AND CARE

## Operational Safety

Secure the machine to prevent movement during maintenance, cleaning, adjustment, accessory assembly, or storage. Do not force the machine. Use the correct machine for your application, as it will perform the job more effectively and safely at its designed capacity. Do not alter the engine governor settings or overspeed the engine, as the governor controls the maximum safe operating speed. Avoid running the engine at high speed when not actively working.

## Contact Hazards

Keep hands and feet away from all rotating parts. Avoid contact with hot fuel, oil, exhaust fumes, and hot surfaces. Do not touch the engine or muffler, as these parts become extremely hot during operation and remain hot for some time after the unit is turned off. Always allow the engine to cool before performing maintenance or adjustments.

## Inspection and Maintenance

If the machine begins to make unusual noise or vibrate, immediately shut off the engine, disconnect the spark plug wire, and investigate the cause, as this often indicates a problem. Use only attachments and accessories approved by the manufacturer to prevent personal injury. Maintain the machine regularly. Check for misalignment or binding of moving parts, part breakage, and any other condition that may affect operation. If damaged, have the machine repaired before use, as many accidents are caused by

## Cleanliness and Disposal

Keep the engine and muffler free of grass, leaves, excessive grease, or carbon buildup to reduce fire hazards. Never douse or spray the unit with water or other liquids. Keep handles dry, clean, and free from debris. Clean the machine after each use. Adhere to proper disposal laws and regulations for gas, oil, and other fluids to protect the environment.

## Storage and Access

Store an idle machine out of the reach of children. Do not allow persons unfamiliar with the machine or these instructions to operate it, as the machine is dangerous in the hands of untrained users.

# SERVICE

## Safety Protocol

Before cleaning, repairing, inspecting, or adjusting the machine, always shut off the engine and ensure all moving parts have stopped. Disconnect the spark plug wire and keep it away from the plug to prevent accidental starting.

## Qualified Service

Have your machine serviced only by qualified repair personnel using identical replacement parts. This ensures the safety of the machine is maintained. Intended Use and Operator Responsibility

This machine is designed exclusively for trench digging and must not be used for any other purpose. It may only be operated by trained personnel who are thoroughly familiar with the contents of this manual. Using or installing parts not approved by your dealer is potentially hazardous. We disclaim all liability for consequences resulting from such use, which also voids the machine warranty.

## Pre-Operation Inspection

Before operating the trencher, ensure the following:  
The operator is fully trained and has read and understood the User Manual.  
All blades are in good condition, securely fastened, and sharpened or replaced in complete sets.  
All fasteners have been checked and are tight.

## Operational Safety

During use, adhere to these procedures:  
Maintain strict discipline and service the machine at specified intervals.  
Always stand in the middle of the two handles, maintaining a safe distance from the engaged wheel to prevent foot injuries.  
Keep body parts, clothing, and foreign objects clear of the rotating auger and digging chain.  
Contact appropriate utility representatives before operation to locate and avoid buried electrical cables, gas lines, or water lines. Contact with utilities can cause severe injury or death.  
Do not operate the machine under the influence of alcohol or drugs.  
Use only in daylight or under illumination exceeding 500 lux. Never operate after dark.

### Personal Protective Equipment (PPE)

This is a high-powered machine with high-energy moving parts.  
Always take these precautions:  
The operator is responsible for accidents involving themselves, other people, or property.  
Always wear protective goggles or safety glasses with side shields to protect against thrown debris.  
Avoid loose clothing or jewelry that could catch on moving parts.  
Wear shoes with non-slip treads; safety shoes are recommended.  
Never operate barefoot or in open sandals.  
Wear earplugs for hearing protection.

## Work Area Safety

Keep all bystanders at least 50 feet (15 meters) away from the work area.  
Stop the engine immediately if another person or pet approaches.  
Safety Regarding Children and Pets  
Tragic accidents can occur; always be alert:  
Keep children and pets at least 50 feet (15 meters) from the work area under a responsible adult's supervision.  
Be alert and turn the machine off if children or pets enter the area.  
Never allow children to operate the trencher.

## Gasoline Safety

Gasoline is highly flammable and its vapors can explode:  
Never run the engine in an enclosed area or without proper ventilation. Engine exhaust contains deadly, odorless carbon monoxide gas.  
Store all fuel and oil in specifically designed, approved containers, away from heat, open flame, and children.  
Replace rubber fuel lines and grommets when worn, damaged, or every 5 years.  
Refuel outdoors with the engine off and cooled. Do not handle gasoline near ignition sources or while smoking. Securely reinstall all fuel caps.  
If gasoline is spilled, do not start the engine. Move the machine from the spill area and avoid ignition sources until vapors dissipate. Wipe up spilled fuel immediately and dispose of the waste properly to prevent a fire hazard.  
Storage and Maintenance Safety  
Allow the engine to cool completely before storing the machine in any enclosure. Never store a machine containing gasoline in its tank, or any fuel container, near an open flame or potential spark source such as a water heater, space heater, clothes dryer, or furnace.  
Never make adjustments or repairs while the engine is running.  
Always shut off the engine, disconnect the spark plug wire and keep it away from the plug to prevent accidental starting. Wait at least five minutes for the engine to cool before beginning any work

## Engine and Component Safety

Never tamper with the engine's governor setting. The governor is calibrated to control the maximum safe operating speed, protecting the engine and other moving parts from damage. Over-speeding the engine is dangerous. For any required adjustments, consult your authorized dealer.  
Keep all combustible substances away from a hot engine. Never cover the machine while the muffler is still hot. Do not operate the engine with the air cleaner or the carburetor air intake cover removed, as this could create a fire hazard. Do not clean the air filter with flammable solutions. Be aware that the muffler and engine become extremely hot during operation and can cause severe burns; avoid contact. it away from the plug to prevent accidental starting.  
Wait at least five minutes for the engine to cool before beginning any work

## Fundamental Operating Precautions

Safe operation of this trencher is necessary to prevent death or serious injury. Always take the following precautions:

This trencher is a powerful tool, not a plaything. Exercise extreme caution at all times.

Use the machine only for its designed purpose of digging trenches. Know how to stop the trencher quickly.

Exercise caution to avoid slipping or falling.

Follow the manufacturer's instructions for proper operation and accessory installation.

Never operate the machine without all guards and shields in place.

## Machine Integrity and Inspection

Never remove, bend, cut, weld, or otherwise alter any standard parts, including all shields and guards. Such modifications can cause personal injury, property damage, and will void the warranty.

If the machine begins to make an unusual noise or vibrate, immediately shut off the engine, disconnect the spark plug wire, and wait five minutes for the engine to cool. Then, inspect for damage.

Vibration is generally a warning of trouble. Check all damaged parts and clean, repair, or replace as necessary.

Never tamper with safety devices. Check their proper operation regularly. Before performing any maintenance or inspection, always shut off the engine, disconnect the spark plug wire, and wait for the machine to cool.

## Operator Responsibility

Never allow individuals unfamiliar with these instructions to operate the trencher. Permit only responsible persons who are thoroughly familiar with these safe operation rules to use the machine.

Never overload the machine or attempt to dig trenches beyond the manufacturer's recommendations, as this can result in personal injury or machine damage. Avoid rushing or taking safety for granted. If you are uncertain about the equipment or your surroundings, stop the machine and assess the situation.

Never operate the machine under the influence of alcohol, drugs, or medication. Use the machine only in daylight. Stay alert for hidden hazards and traffic. Keep all nuts and bolts tight and maintain the equipment in good operating condition.

## A Note to All Users

The provided list of warnings and cautions cannot cover every possible situation. If a scenario occurs that is not addressed in this manual, the operator must apply common sense and operate the trencher in a safe manner. Contact your dealer for assistance.

## UNPACKING THE CONTAINER

Use the screwdriver and hammer to open all the side locks.

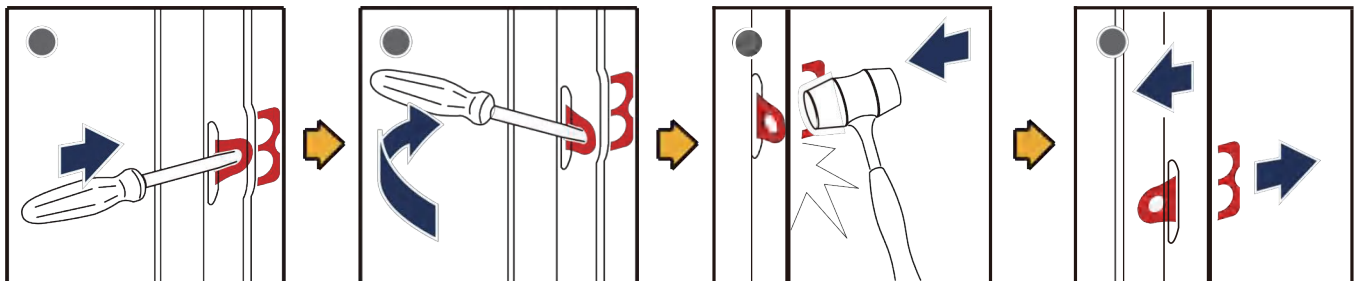

## CONTENTS SUPPLIED

Your Wood chipper comes partially assembled and contains the following:

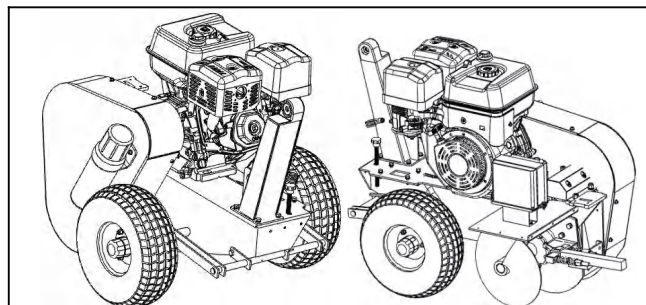

**1x Engine and Base Frame**

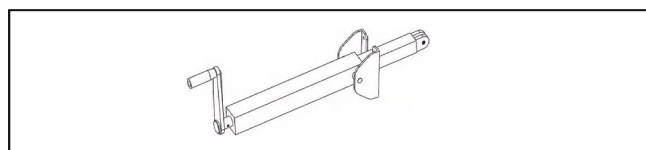

**1x Position Adjustment Part**

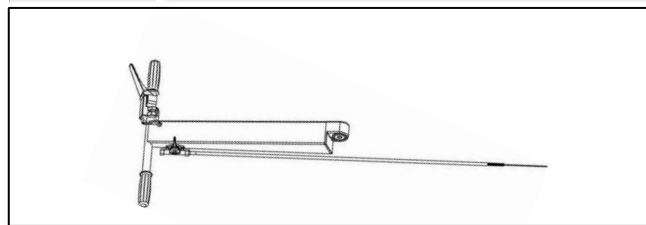

**1x Upper Handle**

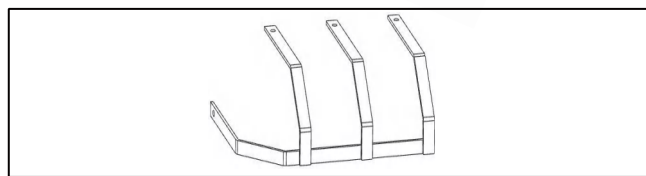

**1x Ridger Shield**

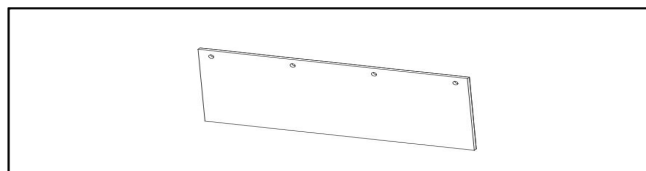

**1x Mudguard**

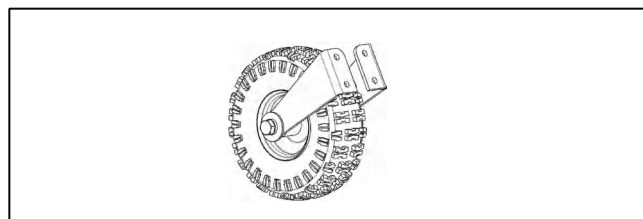

**1x Front Tire**

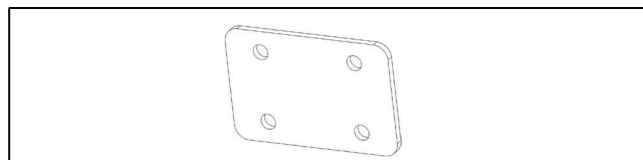

**1x Front Tire Locking Block**

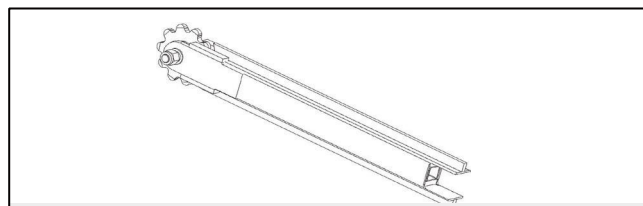

**1x Chain Guard**

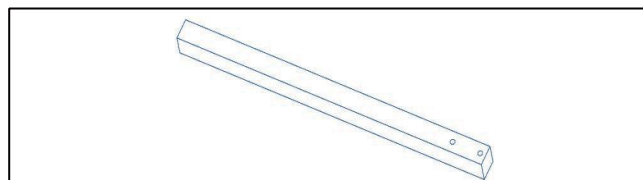

**1x Square Steel Bar**

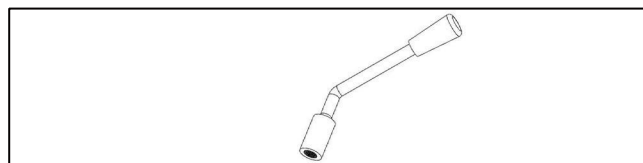

**1x Adjustment Handle**

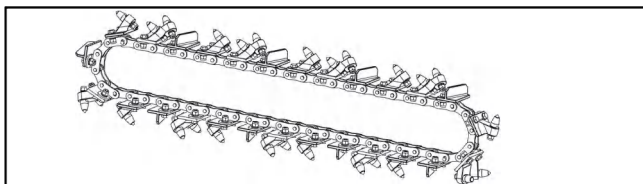

**1x Chain**

## ASSEMBLY

### 1.Upper Handle

Attach the upper handle to the lower handle using 1 Hex head bolt M16X90 and Adjustment Handle.(See Figure 1)

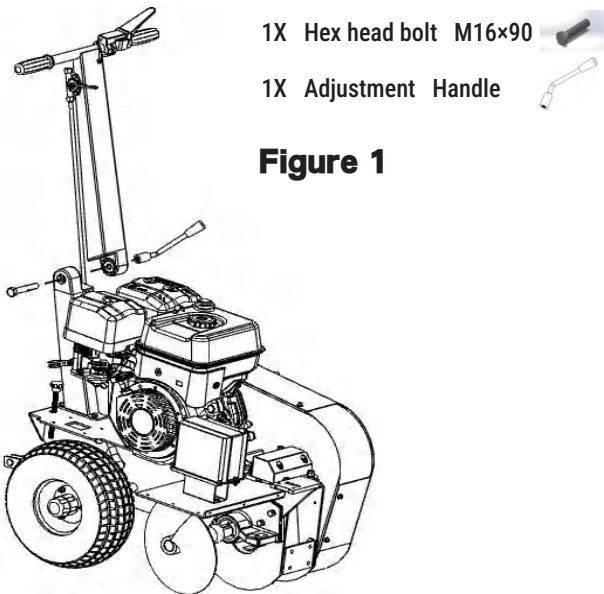

### 3.Square Steel Bar

Mount the square steel bar onto the bracket main plate using 2 units Hex head bolt M8x45, 2 units Flat washer 8, 2 spring washer 8.(See Figure 3)

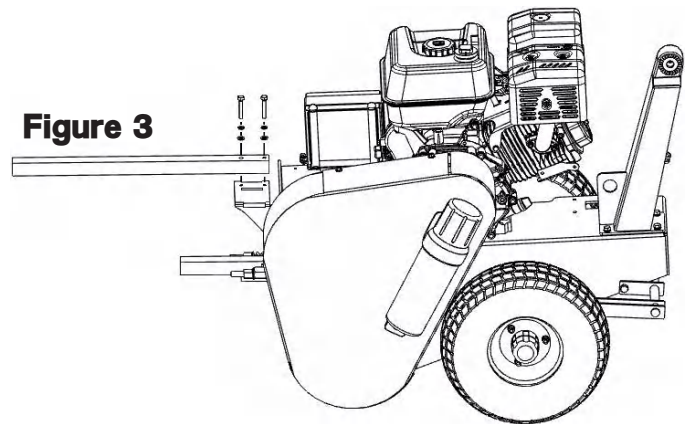

### 2.Position Adjustment Part

Install the original position adjustment mechanism on top of the main frame plate using 4 units Hex head bolt M8x25, 4 units Flat washer 8, 4 units spring washer 8, 4 units lock nut M8(See Figure 2).

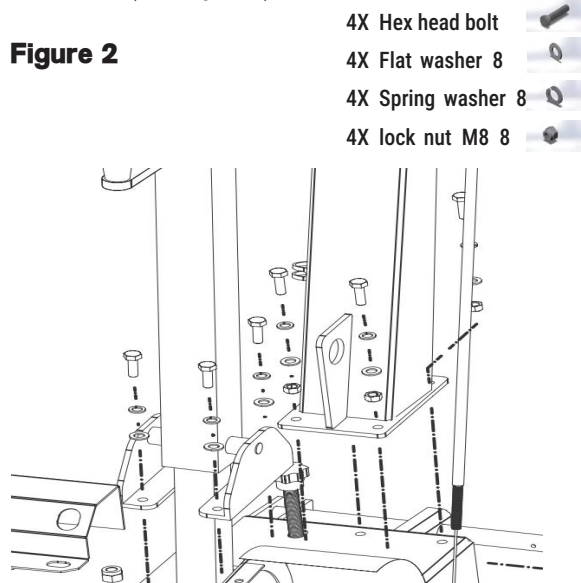

### 4.Chain Guard

Slide the trencher chain guard welding assembly over the short square steel. (See Figure 4)

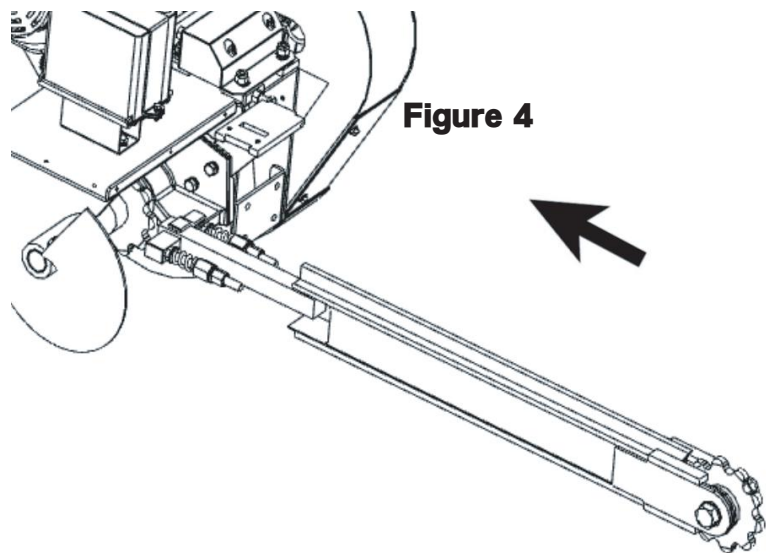

## 5.Chain

Install the trencher chain onto the chain guard assembly.  
(See Figure 5)

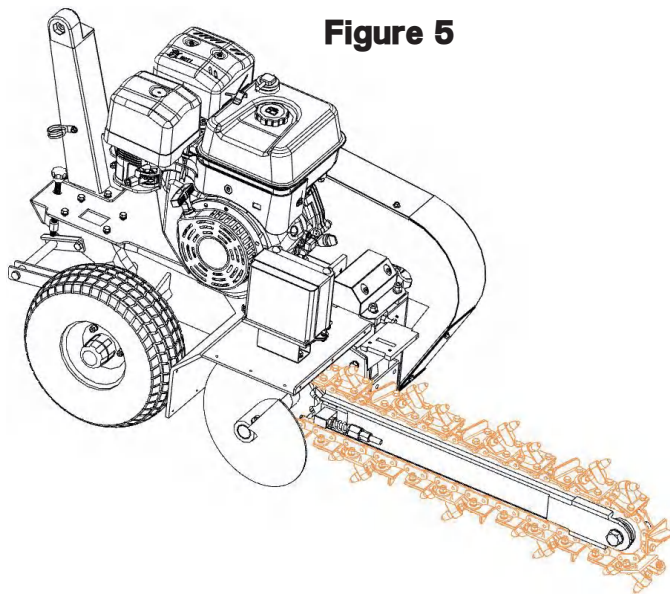





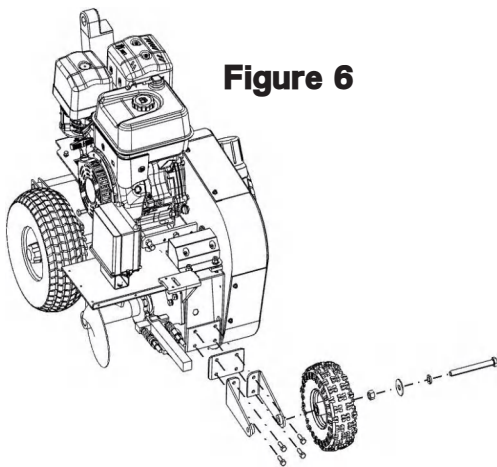

**Figure 5**

## 6.Front Wheel

Install the front wheel using 1 front tire locking block inside and then attach 2 side plates with 4 units Hex Head Bolt M10x30, then attach tire to the plates with 1 hex head bolt M16\*150, spring washer 16, large washer 16, and lock nut M16 each.  
(See Figure 6)

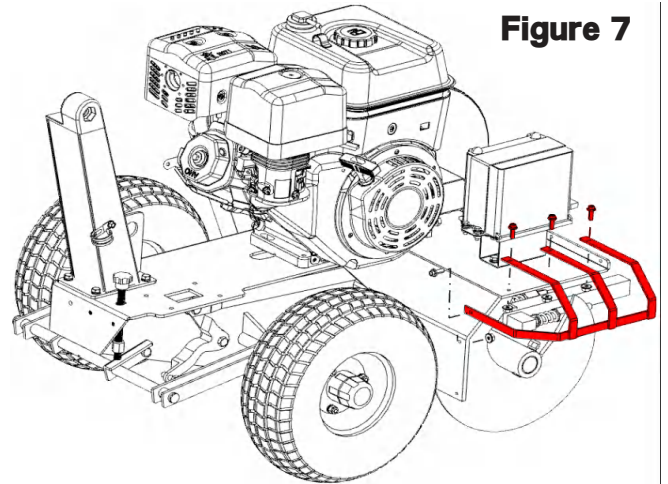

**Figure 6**

- 1X Front Tire Locking Block 
- 2X Side Plate 
- 4X Hex Head Bolt M10x30 
- 1X Hex Head Bolt M16x150 
- 1X Spring Washer 16 
- 1X Large Washer 16 
- 1X Lock Nut M16 

## 7.Ridger Shield

Prioritize the installation of the Ridger Shield. Position it onto the frame and securely fasten it using the provided hardware.



**Figure 7**

- 4X Hex lock nut M6
- 4X Hex bolt M6X20mm

## KNOW YOUR MACHINE

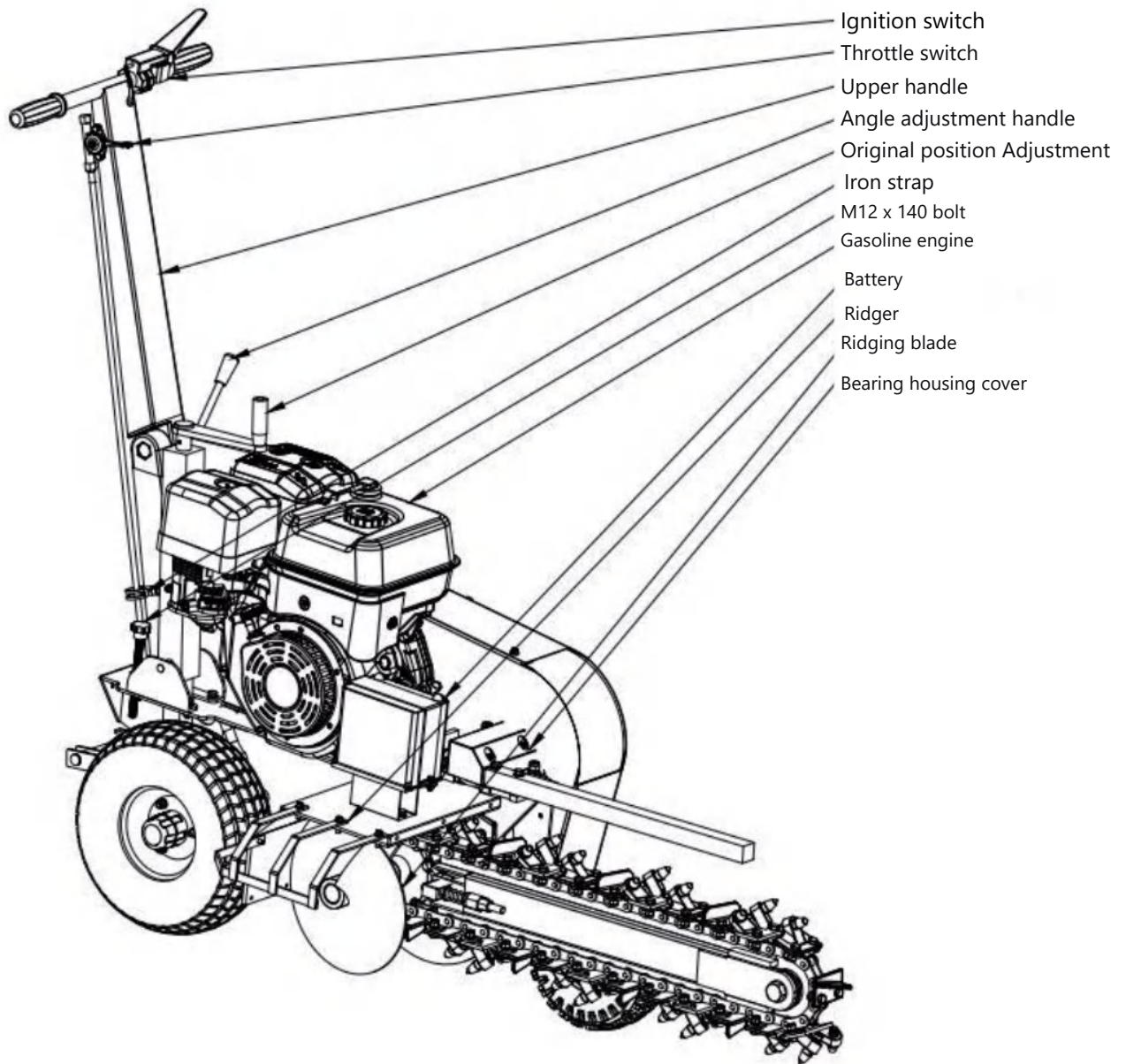

## KNOW YOUR MACHINE

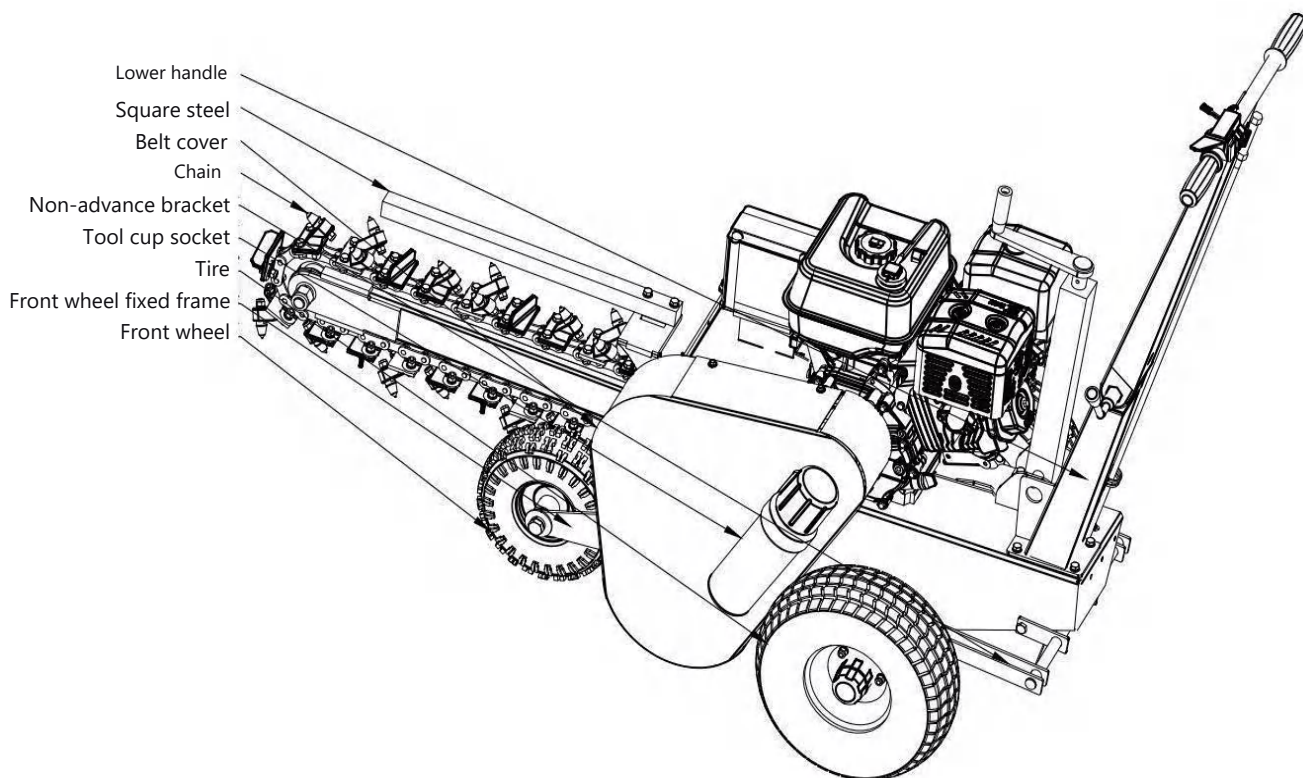

## OPERATION



The engine is shipped without oil. Do not start the engine before adding oil.

### ADD OIL TO ENGINE

1. Make sure the trencher is on a flat, level surface.

Unscrew and pull out the oil dipstick.

Add engine oil as needed.

Reinsert the dipstick completely, then remove it again to check the oil level.

The correct oil level is between the "Low" (MIN) and "Full" (MAX) marks on the dipstick.

Once the level is correct, securely screw the dipstick back into place.



Fill the fuel tank outdoors, never indoors. Gasoline vapors can ignite if they collect inside an enclosure. Explosion can result.

1. The engine must be off and allowed to cool at least two minutes before adding fuel.

2. Remove the fuel filler cap and fill the tank. (See engine manual for fuel capacity, fuel recommendation, and location of fuel cap.)

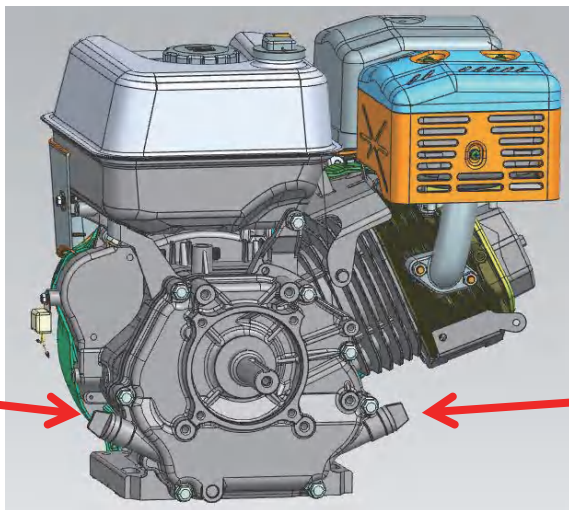
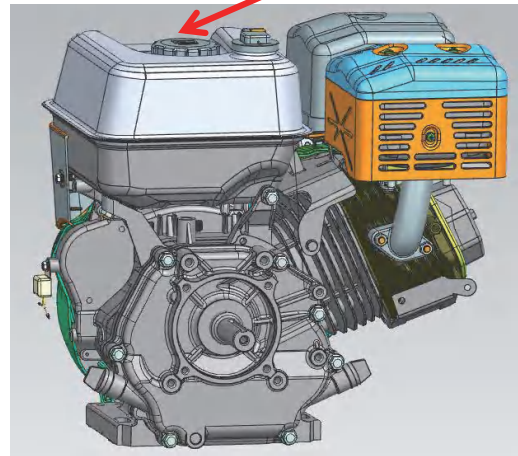

Oil Dipstick

Oil Plug



**DO NOT OVERFILL.** Check engine oil level daily and add as needed.



### ADD GASOLINE TO ENGINE

Gasoline is highly flammable and explosive. You can be burned or seriously injured when handling fuel. Use extreme care when handling gasoline.



### IMPORTANT: DO NOT OVERFILL !

This equipment and/or its engine may include evaporative emissions control system components, required to meet EPA and/or CARB regulations, that will only function properly when the fuel tank has been filled to the recommended level. Overfilling may cause permanent damage to evaporative emissions control system components. Filling to the recommended level ensures a vapor gap required to allow for fuel expansion. Pay close attention while filling the fuel tank to ensure that the recommended fuel level inside the tank is not exceeded. Use a portable gasoline container with an appropriately sized dispensing spout when filling the tank. Do not use a funnel or other device that obstructs the view of the tank filling process.

## Precautions for starting the machine

The following is for reference only: the machine startup process and stoppage

1. Unscrew the dipstick from the oil filler neck, add an appropriate amount of oil. The standard for proper oil level is that when the dipstick is reinserted, the oil should immerse between the lower mark and upper mark on the dipstick. After adding the oil, screw the dipstick back into place.

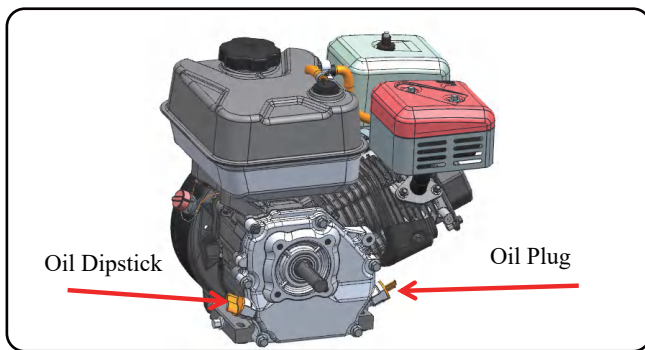

2. Unscrew the gasoline cap, add an appropriate amount of gasoline and rotate the gasoline cap after filling

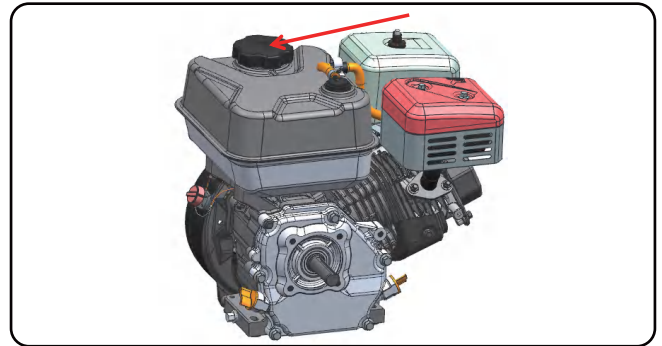

3. Turn on the throttle switch on the carburetor (dial to the right)



4. Turn on the engine switch (the switch is turned on to the ON position)

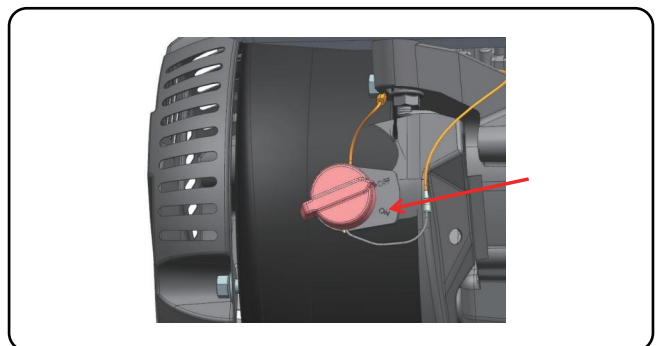

5. Close the choke on the carburetor (dial left)

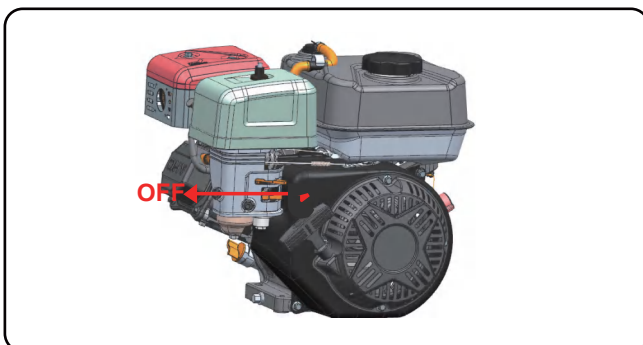

### Ignition Switch

To start the engine, press and hold the ignition switch. This applies to both electric start and pull-start methods.

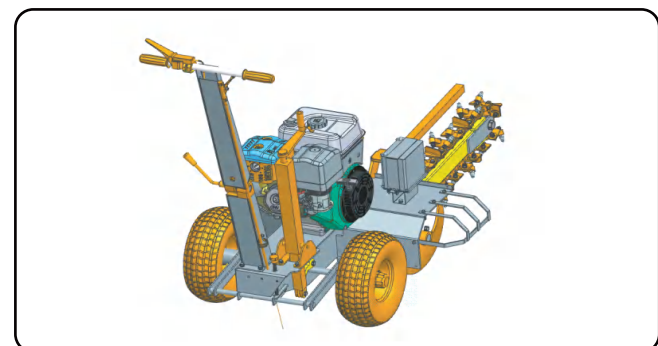

6. recoil start pull the recoil starter rope

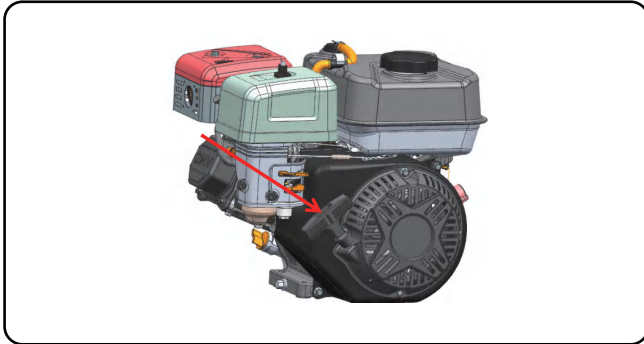

7. Electric Start: Turn on the electric starter switch to the start position.



8. Open the choke (Pull it to the right) 1-2 seconds after starting.

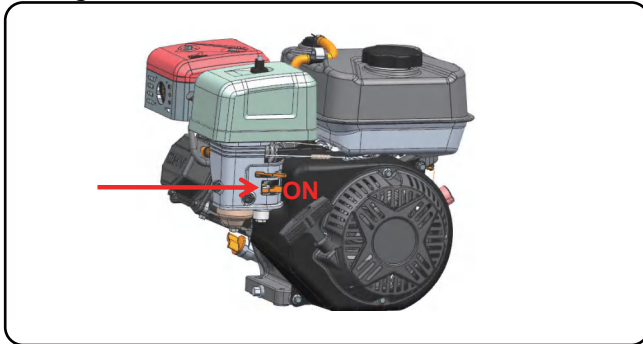

9. To stop the machine, press the ignition switch again.

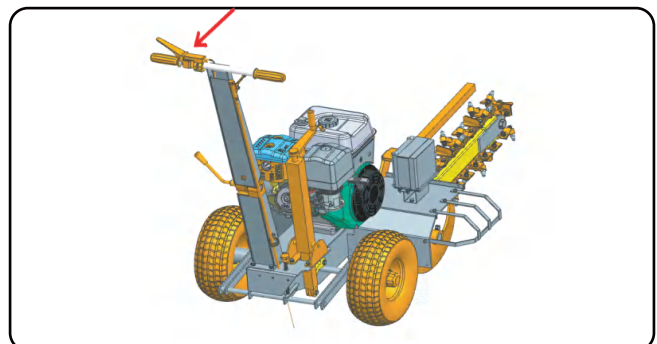

10. If the machine is to be stopped for a long time turn off the kill switch (switch is turned to the OFF position)

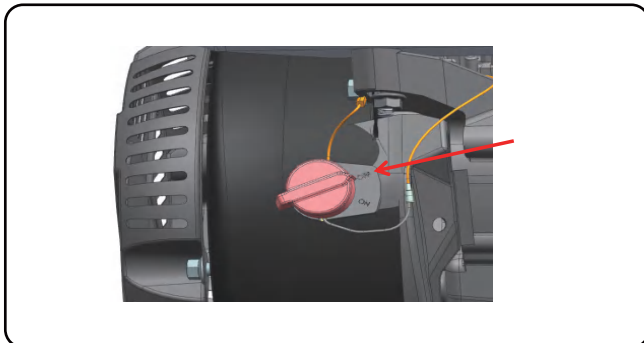

## WORKING AREA

Never start or operate the machine indoors or in any enclosed area. Engine exhaust contains carbon monoxide, a colorless, odorless, and deadly gas. Operate the unit only in a well-ventilated outdoor location. Additionally, never operate the machine under conditions of poor visibility or inadequate lighting.

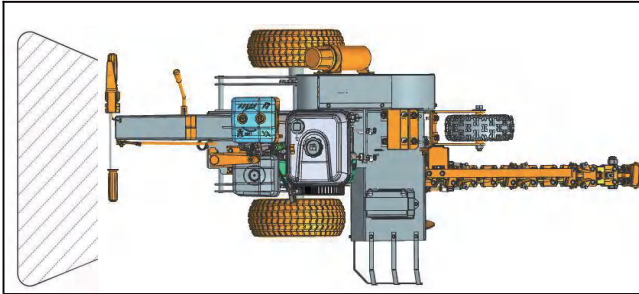

## TRENCHING

Ensure the digging chain is completely stationary when the engine is at idle. Before relocating the trencher within the job site, the engine must be shut off or running at idle speed. To adjust the operating position, rotate the height adjustment handle to set the upper handlebar to your preferred and most comfortable height. All depth measurements are approximate. Actual trench depth can vary based on soil conditions and the degree of trencher blade wear. Furthermore, the actual trenching speed and performance are directly influenced by soil composition and operator expertise.

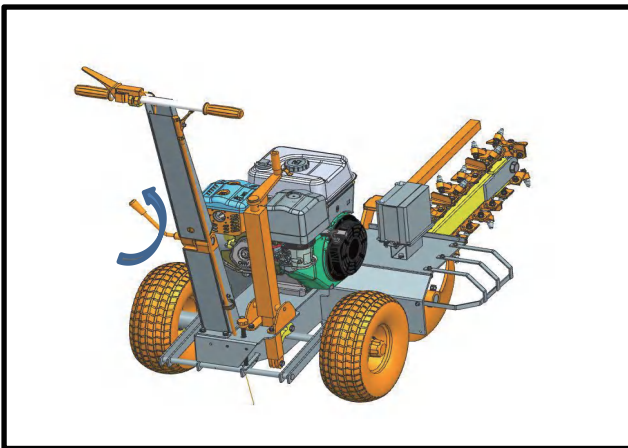

## A GENERAL DESCRIPTION ON HOW TO TRENCH:

Rotate the depth control handle counterclockwise to raise the digging chain.

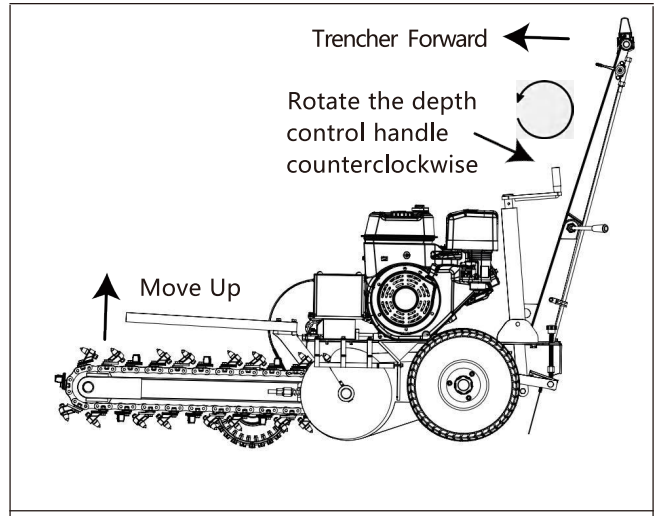

The trencher can now be pushed forward to the desired starting point.

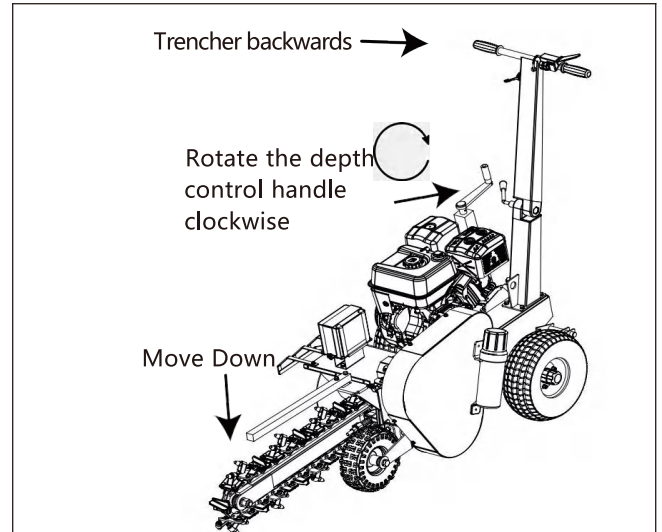

Rotate the depth control handle clockwise. Lower the digging chain to your desired depth. Note: The maximum trenching depth is 60 cm (24 inches). As the chain engages the soil, steadily pull the trencher backward to create the trench.



For your safety, depress the brake bracket on the red color part (Below Picture) when attempting to move the trencher's tires.

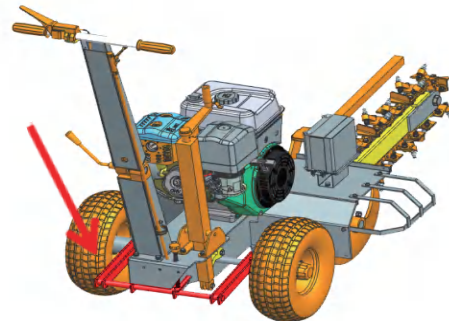

## STOPPING

There are two stop switches on the trencher; one on the handle bar and one on the engine. Refer to the engine manual for the switch location on your trencher. The operator can turn the trencher off at any time by switching either stop switch to the "OFF" position. Both switches must be "ON" before the engine can start.

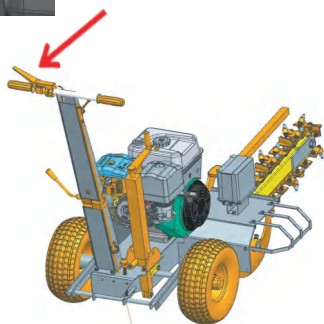
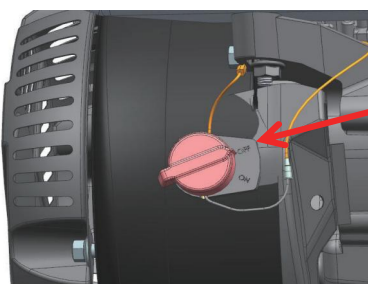

## STOPPING THE ENGINE FOLLOWING THE PROCEDURES:

Switching stop switch on handle.

Move the Throttle Lever to IDLE.

Electric Start: Turn the switch to the OFF position ;

Recoil Start: Turn the ignition switch to the OFF position.

## WHEN BLOCKED

STOP the engine immediately.

After the engine has come to a complete stop, carefully clear away any mud, debris, or obstructions from the chain and trenching assembly.

Once cleared, restart the engine and resume digging

## OPERATOR SAFETY

Always use extreme caution while operating tool. Be sure of your footing and physical capabilities.

Pre-Use Inspection: Inspect the entire machine before each use. Replace any damaged or worn parts immediately.

Maintenance: Grease all rack and pinion gears prior to every operation.

Personal Protective Equipment (PPE): Always wear appropriate safety gear, including:

Eye and hearing protection

A hard hat

Safety boots

Heavy-duty gloves

Long pants

A dust mask (where required)

Physical Safety: Keep hair, loose clothing, fingers, and all body parts away from openings and moving parts. Secure long hair above shoulder level.

Operating Environment: Operate the trencher OUTDOORS only, in a well-ventilated area. Never operate indoors.

Operator Condition: Never operate when fatigued, ill, or under the influence of alcohol, drugs, or medication.

Underground Hazards: Always assume there are buried utilities. Contact local utility companies to locate and mark underground cables, gas lines, and water pipes BEFORE you start digging.

Awareness & Footing: Maintain solid footing and be constantly aware of your surroundings and physical capabilities.

## TRENCHER OPERATIONAL DEMONSTRATION

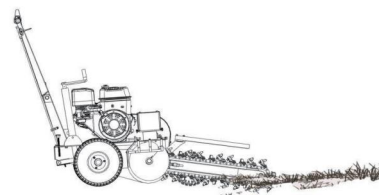
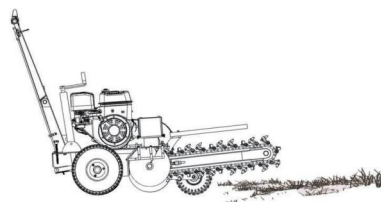

## MAINTAINING YOUR TRENCHER

### MAINTENANCE SAFETY

Before performing any maintenance or inspection, always stop the engine and wait at least five minutes for all components to cool down.

Disconnect the spark plug wire and secure it away from the spark plug. For electric-start models, also disconnect the battery terminals.

Always ensure the engine is stopped before removing the fuel cap.

Use only genuine replacement parts approved by the engine manufacturer.

### LUBRICATION

Recommended Engine Oil: Use 4-stroke gasoline engine oil. The recommended specification is SF grade under the API service classification, or SAE 10W-30 (which is equivalent to SG grade).

#### SAE

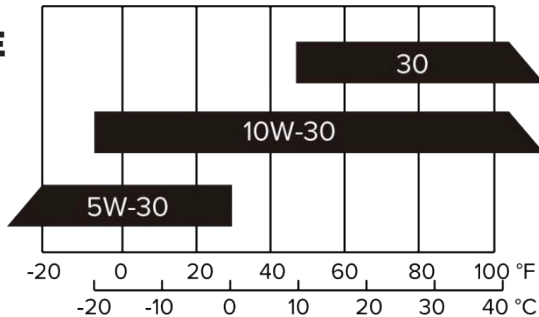

#### AMBIENT TEMPERATURE

### Belt Replace

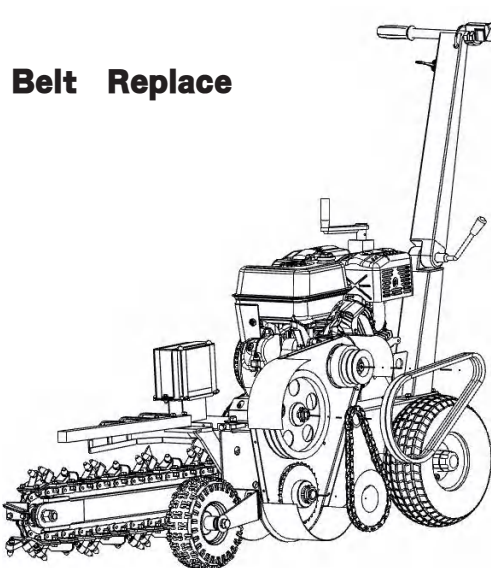

### GREASE FITTING

Grease is applied to bearings, gears, and other components that require durable lubrication and sealing. This helps protect the machine from premature wear and aging.

Keep all grease fittings clean and perform regular lubrication maintenance

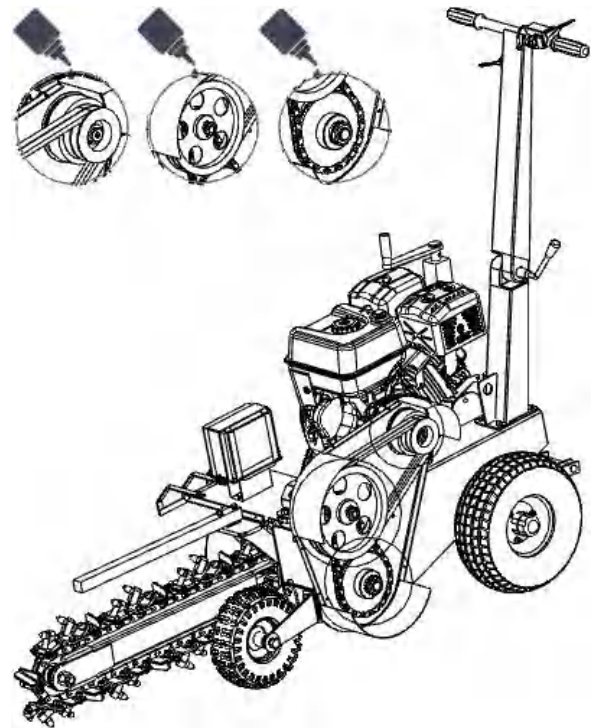

## Maintenance The Mini Trencher

Regular maintenance is the way to ensure the best performance and long life of your machine. Please refer to this manual and the engine manufacturer's user manual for maintenance procedures.

### **WARNING**

Before performing any maintenance procedure or inspection, stop the engine, wait five minutes to allow all parts to cool. Disconnect the spark plug wire, keeping it away from the spark plug. Disconnect the Battery Terminals (Electric start only).

### Regular Maintenance Checklist

| Procedure                         | Before Each Use      | Every 3 Hours | Every 25 Hours | Every 100 Hours |
|-----------------------------------|----------------------|---------------|----------------|-----------------|
| Check engine oil level            | Δ                    |               |                |                 |
| Check general equipment condition | Δ                    |               |                |                 |
| Check wedge for sharpness         | Δ                    |               |                |                 |
| Check belts                       | Δ                    |               |                |                 |
| Check tire pressure               |                      |               | Δ              |                 |
| Clean engine exterior and cooling |                      |               | Δ              |                 |
| Change Engine Oil                 | First time<br>5hours |               | Δ              |                 |
| Replace air filter                |                      |               | Δ              |                 |
| Replace spark plug                |                      |               |                | Δ               |

### Engine Service

Refer to the engine manufacturer's user manual for engine maintenance.

#### Lubrication

### **NOTICE**

All Bearings of your Chipper are sealed units and should have sufficient lubricant to last the life of your machine with normal use.

#### Greasing the rack and Pinion

### **NOTICE**

All the rack and pinion should be greased before every use.

## Troubleshooting Table

| SYMPTOM   | POSSIBLE CAUSE   |
|---|--|
| <p><i>The engine won't start.</i></p> <p><i>(Please refer to the engine user manual for engine-specific procedures.)</i></p>                            | <ul style="list-style-type: none"> <li>➤ <i>Is the ignition switch in the "ON" position?</i></li> <li>➤ <i>Is the fuel shut-off valve on?</i></li> <li>➤ <i>Are you using fresh, clean gas? If the gas is old, change it. Use a fuel stabilizer if you keep gas longer than 30 days.</i></li> <li>➤ <i>Is the spark plug clean? If the spark plug is dirty or cracked, change it. If it's oily, leave it out, hold a rag over the plug hole and pull the recoil cord several times to blow out any oil in the cylinder, then wipe off the plug and reinsert it.</i></li> </ul>   |
| <p><i>The engine lacks power or is not running smoothly.</i></p> <p><i>(Please refer to the engine user manual for engine-specific procedures.)</i></p> | <ul style="list-style-type: none"> <li>➤ <i>Check that the Throttle Lever is in the "Run" position.</i></li> <li>➤ <i>Is the air filter clean? If it's dirty, change it following the procedure in the engine manufacturer's owner's manual.</i></li> <li>➤ <i>Is the spark plug clean? If it's fouled or cracked, change it. If it's oily, leave it out, hold a rag over the plug hole and pull your recoil cord several times to blow out any oil in the cylinder, then wipe off the plug and reinsert it.</i></li> <li>➤ <i>Are you using fresh, clean unleaded gas? If it's old, change it. Use a fuel stabilizer if you keep gas longer than 30 days.</i></li> <li>➤ <i>Does your engine have the right amount of clean oil? If it's dirty, change it following the procedure in the engine manufacturer's owner's manual.</i></li> <li>➤ <i>Check the oil level and adjust as needed.</i></li> </ul> |
| <p><i>Engine smokes.</i></p> <p><i>(Please refer to the engine user manual for engine-specific procedures.)</i></p>                                     | <ul style="list-style-type: none"> <li>➤ <i>Check the oil level and adjust as needed.</i></li> <li>➤ <i>Check the air filter and clean or replace if needed.</i></li> <li>➤ <i>You may be using the wrong oil—too light for the temperature. Refer to your Engine Owner's Manual for detailed information.</i></li> <li>➤ <i>Clean the cooling fins if they're dirty.</i></li> </ul>   |
| <p><i>Machine does not seem to have full chipping power.</i></p>  | <ul style="list-style-type: none"> <li>➤ <i>The belts may be too loose and slipping. Adjust or replace belts as need.</i></li> </ul>   |

## PARTS LIST

| No | DESCRIPTION                                      | QTY |
|----|--|-----|
| 1  | (New) 15HP Anti-Kickback Frame Right Short Plate | 1   |
| 2  | (New) 15HP Anti-Kickback Frame Long Plate, Qty 4 | 4   |
| 3  | Anti-Kickback Frame Cover Plate                  | 2   |
| 4  | Anti-Kickback Frame Round Tube                   | 1   |
| 5  | Anti-Kickback Frame Short Plate                  | 1   |
| 6  | Ratchet Wheel                                    | 2   |
| 7  | Ratchet Wheel Tube                               | 2   |
| 8  | Home Position Adjustment Mechanism               | 1   |
| 9  | M12x140 Bakelite Bolt                            | 1   |
| 10 | Rotating Plate                                   | 1   |
| 11 | Handle   | 1   |
| 12 | 15HP Gasoline Engine                             | 1   |
| 13 | Rotating Block Spacer                            | 1   |
| 14 | Front Wheel Fixing Base                          | 1   |
| 15 | GB-T70.1-2000, Hex Socket Bolt M10x60            | 1   |
| 16 | Compression Spring 14x22x72                      | 2   |
| 17 | GB804-1988, Retaining Ring M12                   | 2   |
| 18 | GB-T95-2002, Flat Washer M12                     | 6   |
| 19 | GB-T5780-2000, Bolt M12x120                      | 2   |
| 20 | GB-T95-2002, Flat Washer M8                      | 164 |
| 21 | GB859-87, Light Spring Washer 8                  | 101 |
| 22 | GB-T6182-2000, Nut M8x1.25                       | 87  |
| 23 | Double Cutter Holder                             | 9   |
| 24 | Steel Plate Cutter Head                          | 9   |
| 25 | Cutter Tip                                       | 27  |
| 26 | Cutter Body                                      | 27  |
| 27 | Single Cutter Holder                             | 9   |
| 28 | 15HP Gasoline Engine                             | 68  |
| 29 | Trencher Closing Chain Link                      | 1   |

| No | DESCRIPTION  | QTY |
|----|--|-----|
| 30 | Main Trencher Chain Link                             | 1   |
| 31 | GB-T6182-2000, Nut M20X2.5                           | 1   |
| 32 | GB7244-87, Washer 20                                 | 1   |
| 33 | GB-T97.1-2002, Washer M20                            | 1   |
| 34 | GB-T5781-2000, Bolt M20X100                          | 1   |
| 35 | GB812-88, Nut M30X1.5                                | 2   |
| 36 | Driven Trencher Sprocket Cover                       | 2   |
| 37 | M30 Round Nut Lock Washer                            | 1   |
| 38 | Driven Sprocket                                      | 1   |
| 39 | Ridger Spacer  | 1   |
| 40 | Drive Trencher Sprocket                              | 1   |
| 41 | Large Sprocket Shaft                                 | 1   |
| 42 | Sprocket Shaft Plate                                 | 1   |
| 43 | Short Square Steel                                   | 1   |
| 44 | Trencher Chain Tensioning Block                      | 1   |
| 45 | Short Square Steel Reinforcement Plate               | 2   |
| 46 | Extension Rod Fixing Plate                           | 1   |
| 47 | GB56-1988, Nut M16                                   | 1   |
| 48 | Trencher Chain Roller Guide                          | 2   |
| 49 | Chain Frame Nut Spacer Block                         | 1   |
| 50 | Trencher Chain Frame Inner Square Tube Welding Block | 1   |
| 51 | Ridger Blade   | 1   |
| 52 | Ridger Shaft Sleeve                                  | 1   |
| 53 | Hub Rubber Cap                                       | 2   |
| 54 | Tire 15x6.00-6                                       | 2   |
| 55 | Seal Ring 47   | 4   |
| 56 | Spacer 25 22 23                                      | 1   |
| 57 | Spacer 25 22 8                                       | 1   |
| 58 | GB-T292-1994, Bearing 7204AC                         | 4   |

| No | DESCRIPTION   | QTY |
|----|---|-----|
| 59 | Ratchet Wheel Fixing Block  | 2   |
| 60 | GB812-88, Nut M20x1.5   | 3   |
| 61 | M20 Round Nut Lock Washer   | 2   |
| 62 | Ridger Protector Longitudinal Bar   | 1   |
| 63 | Ridger Protector Cross Bar  | 3   |
| 64 | GB-T41-2000, Nut M10x1.5  | 3   |
| 65 | GB-T5781-2000, Bolt M10x30  | 1   |
| 66 | GB-T95-2002, Flat Washer M10  | 4   |
| 67 | GB12-88, Bolt M10x40  | 4   |
| 68 | Drive Sprocket  | 1   |
| 69 | Grease Nipple   | 2   |
| 70 | P205 Pillow Block Bearing   | 2   |
| 71 | Pulley Shaft  | 1   |
| 72 | 10A Roller Closing Chain Link   | 1   |
| 73 | Clutch  | 1   |
| 74 | Spacer 26x30x9.5  | 1   |
| 75 | Belt Pulley / Sheave  | 1   |
| 76 | Conventional V-Belt   | 2   |
| 77 | GB-T5781-2000, Bolt M10x80  | 2   |
| 78 | Bearing Housing Cover Side Plate  | 1   |
| 79 | Bearing Housing Cover Main Plate  | 6   |
| 80 | GB/T6185-2000, Hexagon Prevailing Torque Nut (All Metal Type 2) M8 -      | 8   |
| 81 | GB882-88, Clevis Pin (Type A) 10x35 -                                     | 2   |
| 82 | GB/T16674-1996, Hexagon Flange Bolt (Small Series) M7x20                  | 13  |
| 83 | GB-T5780-2000, Bolt M10x30  | 10  |
| 84 | GB/T96.2-2002, Large Washer (Product Grade C) 16x3 -                      | 1   |
| 85 | GB/T7244-1987, Heavy Spring Washer (Assembled) 16x4.8                     | 1   |
| 86 | GB/T5781-2000, Hexagon Head Bolt (Full Thread, Product Grade C) M16x150 - | 1   |
| 87 | GB/T6185-2000, Hexagon Prevailing Torque Nut (All Metal Type 2) M16 -     | 1   |

| No  | DESCRIPTION   | QTY |
|-----|---|-----|
| 88  | Bracket Main Plate  | 1   |
| 89  | Bracket Fixing Plate                                      | 1   |
| 90  | Trencher Chain Cover Square Steel                         | 1   |
| 91  | GB-T5781-2000, Bolt M8X45                                 | 2   |
| 92  | GB-T5780-2000, Bolt M10X20                                | 2   |
| 93  | Tool Cup Lid  | 1   |
| 94  | Tool Cup Body   | 1   |
| 95  | Spring Washer 2   | 5   |
| 96  | Flat Washer   | 3   |
| 97  | Square Nut  | 3   |
| 98  | Bolt 2  | 2   |
| 99  | Bolt  | 3   |
| 100 | Flat Washer 2   | 2   |
| 101 | Clamping Strip  | 1   |
| 102 | Battery Top   | 1   |
| 103 | Battery Box   | 1   |
| 104 | Battery Cover Bottom                                      | 1   |
| 105 | Battery Cover   | 1   |
| 106 | Battery   | 1   |
| 107 | Belt Cover Base Plate Thk 1.5                             | 1   |
| 108 | Cold Rolled Sheet Cover Right Arc Plate                   | 1   |
| 109 | Cold Rolled Sheet Cover Lower Arc Plate                   | 1   |
| 110 | Cold Rolled Sheet Cover Upper Arc Plate                   | 1   |
| 111 | Engine & Bearing Seat Adjustment Block<br>5144            | 1   |
| 112 | Right Front Wheel Bracket (New)                           | 1   |
| 113 | Left Front Wheel Bracket (New)                            | 1   |
| 114 | Spacer 16 30 10   | 2   |
| 115 | Tire 4.10-4   | 1   |
| 116 | Chain Frame Reinforcement Plate (New)                     | 4   |
| 117 | Chain Frame Reinforcement Block                           | 4   |
| 118 | 7HP Trencher Thk 5 (Welded) Adjustable<br>Extension Rod 2 | 2   |

| No  | DESCRIPTION                | QTY |
|-----|----------------------------|-----|
| 119 | 10A Roller Chain Link      | 1   |
| 120 | Wheel Axle                 | 1   |
| 121 | Front Wheel Fixing Block   | 1   |
| 122 | Upper Handle               | 1   |
| 123 | GB-T5780-2000, Bolt M16X90 | 1   |
| 124 | Angle Adjustment Handle    | 1   |
| 125 | Mudguard / Fender          | 1   |
| 126 | Driven Trencher Sprocket   | 1   |

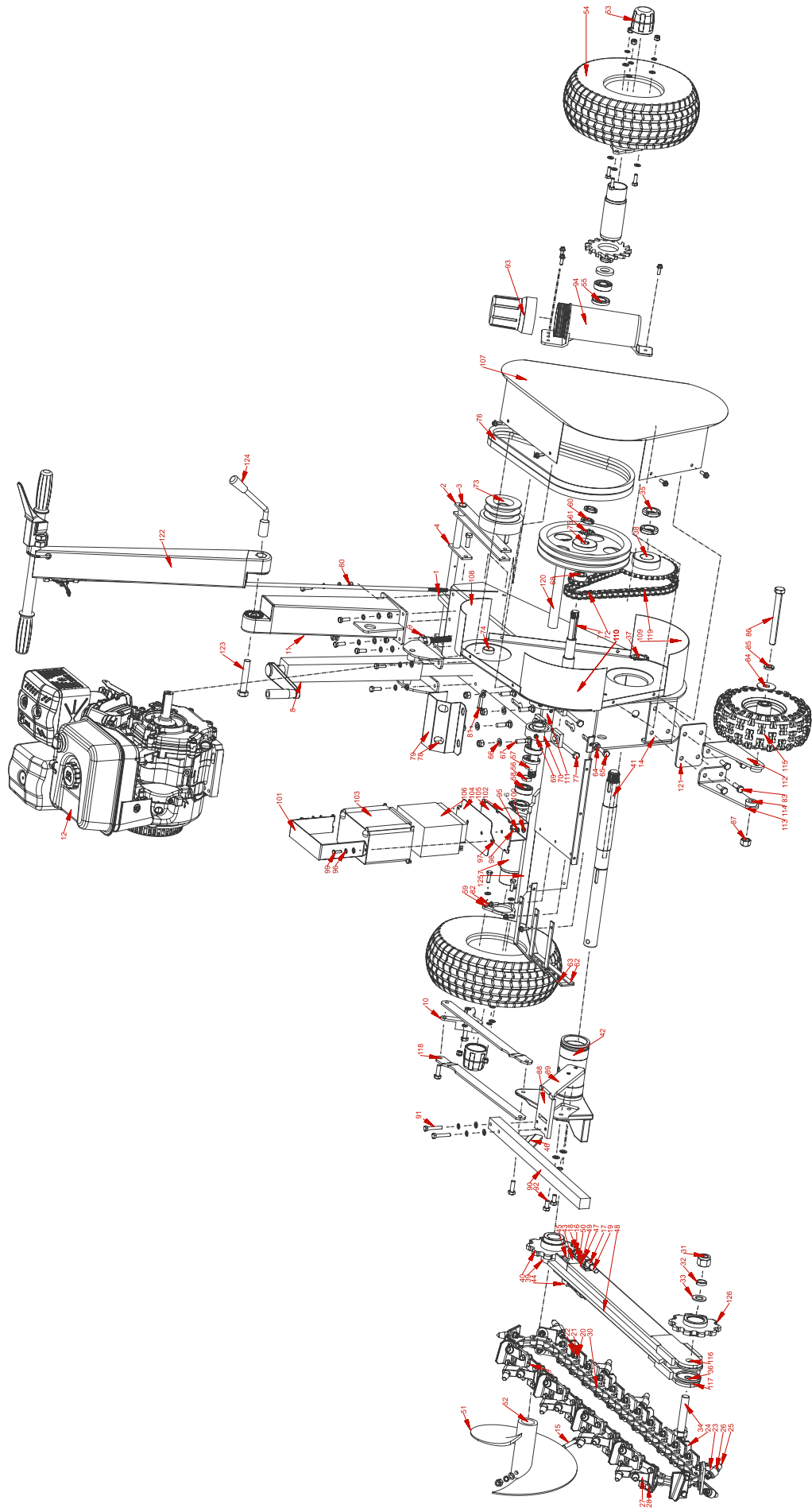

Video on Youtube

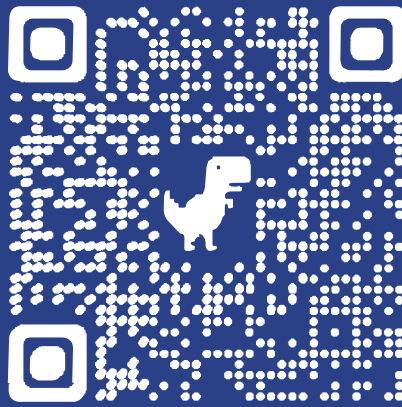

***BILT HARD***

Service information,

Customer Support (888)680-2849,

[inquiry@bilthardusa.com](mailto:inquiry@bilthardusa.com)