

**MODEL: CHM24V**

Contact us at [cs@adamaxinc.com](mailto:cs@adamaxinc.com) or via our website at [newhousehardware.com](http://newhousehardware.com) with any questions.

The figures below and on page 2 are referenced with the notes below, as well as the chime removal, installation instructions and troubleshooting, which are on pages 3 and 4.

\*If the existing chime has already been removed, see the section "Installing a replacement chime" on page 4.

**IMPORTANT BEFORE AND AFTER INSTALLING:**

- Power MUST be supplied from a 24V AC, 40-Watt transformer.
- Remove the two cable ties and white cotton pieces that are beneath the Tone Bars (see figure 1 for the image of the tone bars).
- DO NOT remove the foam piece that is above the plunger that makes the sound for the REAR or side door (see figure 3).
- NEVER use cleaners, polish or any fluids on the chime base. Use a dry cloth to clean the chime cover and base.
- Not all regular lighted doorbell buttons will work with this 24V chime as most of these buttons are 16V. The button may burn out as a result. Unlighted buttons should work (check with the manufacturer first). Below is a list of Newhouse Hardware button models that will work with this chime:

BR4BL, BR5W, BT1W and FMB

All illustrations may vary from the actual chime unit.

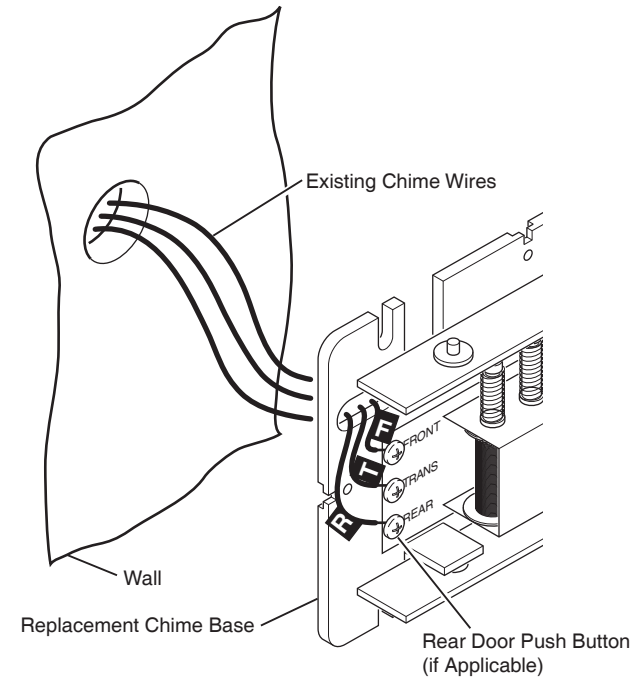

**Figure 2 - Mechanical Chime Wiring**

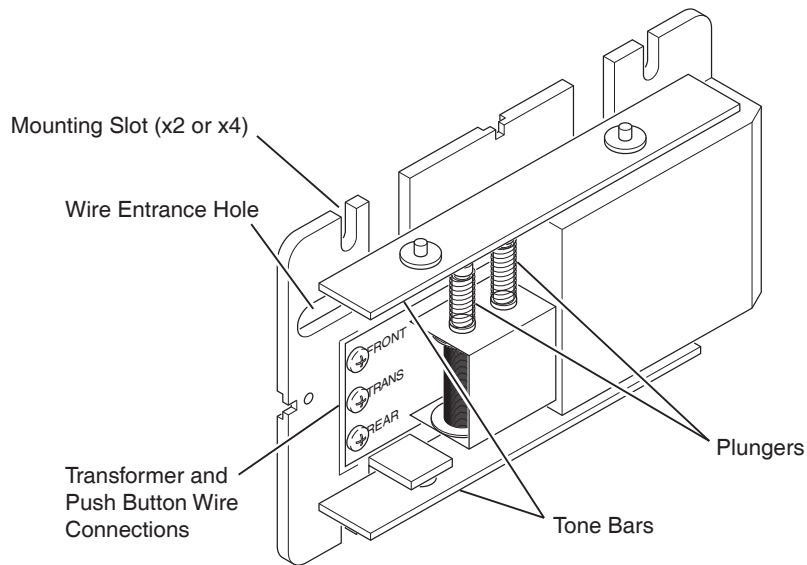

**Figure 1 - Mechanical Chime Identification**

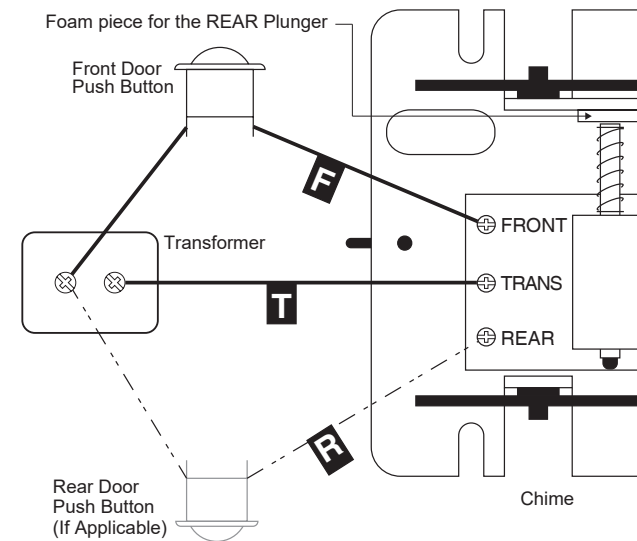

**Figure 3 - Chime System Wiring Diagram**

## Locating and removing an existing doorbell chime

**IMPORTANT:** READ ALL INSTRUCTIONS BEFORE REMOVING THE CHIME.  
FOLLOW ALL NATIONAL AND LOCAL ELECTRICAL CODES.

CONTACT A QUALIFIED ELECTRICIAN IF THERE ARE ANY QUESTIONS AS TO THE SUITABILITY OF THE SYSTEM.

**Step 1: WARNING: Turn the power off at the fuse or circuit breaker before removing the chime.**

**Step 2: Locate your doorbell chime.**

The chime is usually located by the front door, near the ceiling.

**Step 3: Remove the cover.**

Most chimes have a cover that snaps into the chime base. Hold the cover firmly and pull without using too much force and it should come off. If you are unable to hold the cover, gently place a flathead screwdriver underneath one of the edges of the cover and pry it loose.

**Step 4: Check for electricity to the chime.**

Use a voltage tester or voltmeter on the wires connecting to the chime to make sure that no electricity is running through the chime unit.

**Step 5: Mark the terminal wires.**

Most chimes have screw terminals that are marked "Front" (front door), "Rear" (rear or side door wire) and "Trans" (transformer) (see figure 1). The wires coming out of the wall connect to these terminals (you may not have a rear wire). Use masking or electrical tape to label these wires so that you do not forget which wire is which when installing the new chime. Mark "F" for the front wire, "R" for the rear wire and "T" for the transformer wire.

**Step 6: Disconnect the wires.**

Loosen the terminal screws using a screwdriver and remove the wires.

**Step 7: Remove the chime from the wall.**

Unscrew the larger screws on either side of the chime using a screwdriver. If necessary, hold the wires from the back of the chime as you gently pull the chime off of the wall, so they don't fall behind the wall upon release.

**Step 8: Tape the wires in place.**

If necessary, tape all the chime wires in place on your wall so you don't lose them.

## Installing a replacement chime

**IMPORTANT:** READ ALL INSTRUCTIONS BEFORE INSTALLING THE CHIME.  
FOLLOW ALL NATIONAL AND LOCAL ELECTRICAL CODES.

CONTACT A QUALIFIED ELECTRICIAN IF THERE ARE ANY QUESTIONS AS TO THE SUITABILITY OF THE SYSTEM.

**Step 1: WARNING: Turn the power off at the fuse or circuit breaker before removing the chime.**

**Step 2: Locate the doorbell chime wires and thread them through the back of the chime.**

If the wires were taped to the wall, remove the tape and gently thread them through the entrance hole in the chime (see figure 2). Once the wires are through, you can re-tape them temporarily on the chime if you still don't want to risk losing them.

**Step 3: Mount the chime to the wall using the provided screws.**

Position the chime on your wall. If it is the same size as your old chime, you can use the same screw holes. If not, you may need to use a power drill to make the appropriate size holes (use a 1/8 drill bit for CHM24V). Place the screws in their appropriate holes on the chime (these holes are on the left and right side of the chime base). Using a screwdriver or power drill, screw the chime into the wall.

**Step 4: Attach the doorbell wires to screw terminals in the chime.**

Using the labels you made earlier, place each wire on the appropriate screw terminal and use a screwdriver to tighten it in place (see figure 2).

**Step 5: Place the cover over the chime.**

Place chime cover securely over the chime base. Apply pressure to the cover until it snaps into place.

**Step 6: Turn the power back on.**

If you are not replacing the transformer or button, then turn the power back on at the fuse or circuit breaker.

**Step 7: Test the chime.**

Ring the doorbell to test the chime. If below. If the chime is not working properly, check the troubleshooting tips below.

## Troubleshooting

### Chime does not sound or there is a buzzing/humming sound

A mechanical chime will buzz if it is continuously energized. The issue could be with the chime, doorbell button, transformer and/or wiring. These components need to be checked to determine the issue. Try the following:

1. Remove the doorbell button and briefly touch the wires. If the doorbell rings, then the button needs to be replaced/looked at. The button could be stuck or there is a short in the wiring. If the push button(s) are removed and the buzzing continues, the wiring will likely need to be replaced. It is also possible that the wrong wires are connected to the chime (see figure 3 for the wiring diagram).

**\*If the chime that you are replacing is a digital chime (plays a melody; has a speaker for the sound), the diode in the doorbell button wire will need to be removed.**

2. Test the transformer (24V transformer is needed) with a voltage meter. If the transformer is producing less than 24 volts when the chime is playing, then the transformer needs to be replaced.
3. Use a voltage meter to test the chime. If there is current after the doorbell button is pushed, but the chime doesn't ring, then the chime needs to be replaced. If there is no current, then the wiring is bad.

**If the chime is bad or if you have any questions, contact us at [cs@adamaxinc.com](mailto:cs@adamaxinc.com) or [newhousehardware.com](http://newhousehardware.com).**