



**12,000 BTU/18,000 BTU Ductless Mini Split
Air Conditioner with Heat Pump**



**Customer & Technical Support information
(Please contact us BEFORE returning product)**

Website: www.bhiair.com

Contact Phone #: 1-626-427-3298

(Mon-Fri: 9am-5pm/PST)

Email: support@bhiair.com

help@bhiair.com

Read the manual carefully before operation and keep it for reference. This manual is only for reference, please comply with actual appliance you selected. manufacturer hold the authority to redesign or modify its products without notice.

CONTENTS

1. Safety Precautions	
Safety Precautions.....	2
Accessories List.....	5
2. Installation Manual	
Installation Guide.....	6
Installation of Accessories.....	6
Position for Indoor Unit.....	6
Position for Outdoor Unit.....	7
Tubing Selection.....	7
Fixing Installation Panel.....	9
Indoor Unit Installation.....	11
Outdoor Unit Installation.....	13
Tubing Connection.....	14
Connection of Wires.....	15
Drainage.....	18
3. Product Instructions	
Protect Functions.....	19
4. Description of Components	
View of Unit.....	20
Display Screen.....	21
Remote Controller.....	22
5. Service and Maintenance	
Clean the Front Panel and Remote Controller.....	24
Clean Air Filter.....	24
No Use for Long Time.....	25
Recommendations for Energy Saving.....	25
Normal Phenomenon.....	25
6. Trouble Shooting	
Air Conditioner is in Error.....	26
Remote Controller is in Error.....	26
7. TROUBLESHOOTING & WARRANTY	
Troubles Shooting & Warranty.....	27

Safety Precautions

Read before Installation



This symbol indicates ignoring instructions may cause death or serious injury.



This symbol indicates that ignoring instructions may cause moderate injury to your person, damage to your unit, or other property.



This symbol indicates that you should NEVER perform the indicated action.

1.1 People:



Warning

- A. Installation is highly recommended to be performed by an authorized technician. Improper installation may cause water leakage, electrical shock, or fire.
- B. The moving and relocation of the unit also requires consulting an authorized technician for the disconnection and re-installation steps.
- C. Take into account strong winds, typhoons, or earthquakes when installing. Improper installation may result in the unit falling and causing accidents.
- D. When installed 6ft (2m) higher above the floor, the outdoor unit must be tied with ropes and installer has to wear safety belt to prevent personal injury, as well as damage to units.
- E. The heat exchanger fins are sharp enough to cut fingers. To avoid injury wear gloves or cover the fins while working around them.
- F. Do not leave children unattended with the air conditioner.

1.2 Location:



Warning

- A. Install the unit in a firm location that can support the unit's weight. If the installation location cannot support the weight, or the installation is performed improperly, the unit may fall and cause serious injury and/or damage.
- B. Do not install the air conditioner and heat pump in the following locations:
 - (a) Where a mineral oil mist or oil spray or vapor is produced, for example, in a kitchen. Plastic parts may deteriorate and fall off or result in water leakage.
 - (b) Where corrosive gas, such as sulfurous acid gas, is produced. Corroding copper pipes or soldered parts may result in refrigerant leakage.
 - (c) Near machinery emitting electromagnetic waves. Electromagnetic waves may disturb the operation of the control system and cause the unit to malfunction.
 - (d) Where flammable gas may leak, where there is carbon fiber, or ignitable dust

suspension in the air, or where volatile flammables such as thinner or gasoline are handled.

- C. Install the unit where air inlet or air outlet is not blocked. Otherwise, the cooling or heating capacity will be weakened, even stop operating.
- D. Do not let the air conditioner blow against the heater appliance.

1.3 Electricity:

Warning

- A. Make sure that a separate power supply circuit is provided for this unit. An insufficient power supply capacity or improper electrical construction may lead to electric shock or fire.
- B. The circuit must be protected with safety devices in accordance with local and national codes, i.e. a circuit breaker.
- C. Do not ground units to water pipes, telephone wires or lightening rods because incomplete grounding could cause a severe shock hazard.
- D. Do not modify the length of the power supply cord or use an extension cord to power the unit. Only use the specified power cord. If the power cord is damaged, it must be replaced by the manufacturer, its service agent or similarly qualified person in order to avoid a hazard.

CAUTION Caution

- E. After connecting all wiring be sure to shape the cables so that they do not put undue stress on the electrical covers, panels or terminals. Install covers over the wires. Incomplete cover installation may cause terminal overheating, electrical shock, fire or equipment damage.
- F. Do not turn on power until all work/installation has been completed.
- G. For maintenance, turn off the power before touching any electrical part.

1.4 Refrigerant:

Warning

- A. Refrigerant gas is heavier than air and replaces oxygen. If the refrigerant gas leaks during installation, ventilate the area immediately. A massive leak could lead to oxygen depletion, especially in basements, and an asphyxiation hazard could occur leading to serious injury or death.
- B. When installing the unit in a small room, take measures to keep the refrigerant concentration from exceeding allowable safety limits. Excessive refrigerant leaks, in the event of an accident in a closed ambient space, can lead to oxygen deficiency.



CAUTION Caution

- C. Refrigerant R410A in the system must be kept clean, dry, and tight.
 - (a) Clean and Dry-Foreign materials (including mineral oils such as SUNISO oil, moisture or air) should be prevented from getting into the system.
 - (b) Tight- R410A does not contain any chlorine, does not destroy the ozone layer, and does not reduce the earth's protection against harmful ultraviolet radiation. R410A can contribute to the greenhouse effect if it is released. Therefore, take proper measures to check for the tightness of the refrigerant piping installation.
- D. Since R410A is a blend, the required additional refrigerant must be charge in its liquid state. If the refrigerant is charged in a state of gas, its composition can change and the system will not work properly.
- E. During pump-down, stop the compressor before removing the refrigerant piping. If the compressor is still running and the stop valve is open during pump-down, air will be sucked in when the refrigerant piping is remove, causing abnormally high pressure which could lead to equipment damage or and personal injury.
- F. If the system ahs a leak-detection system installed, it should be checked for leaks at least every 12 months. Keeping a record of all leak checks for the lifetime of the unit is strongly recommended.

1.5 Recycle:

- A. Safely dispose of the packing materials
- B. Refrigerant

1.6 Regulation:

- A. In North America, installation must be performed in accordance with the requirement of NEC and CEC (by authorized personnel only.) contact an authorized service technician for repair or maintenance of the unit.
- B. Dismantling the unit, treatment of the refrigerant, oil and additional parts must be done in accordance with the relevant local state, and national regulations.

[Accessories List]

PARTS NAME	QUANTITY
Mounting plate	1
Remote controller	1
Remote controller holder	1
AAA Battery	2
Drain hose	1
Connection cable	1
Gas pipe	1
Liquid pipe	1
Manual & Installation manual	1
Screws	4
Plastic expansive pipe	4
PVC protective strap	1
Cap	1
Elbow joint (Not available in cooling only model)	1

INSTALLATION MANUAL

[Installation Guide]

- This air conditioner meets the safety and operation standards promulgated by the Nation.
- You need to invite professional air conditioner service and maintenance personnel to install or remove the air conditioner. Problems may occur and you may suffer losses if non- professionals install the air conditioner.
- User shall provide the power that meets installation and operation requirements. please refer to nameplate for details about the voltage for this product. Voltage beyond this scope will affect the normal operation of the air conditioner.
- Separate power point with delay fuse protector or automatic breaker should be used for the air conditioner.
- The air conditioner must be correctly and reliably grounded, or it may cause electric shock or fire.
- Do not switch on the power of the air conditioner before well connecting and carefully checking the tubing and wires.
- The appliance shall not be installed in laundry or bathroom.
- In case necessary, please consult your supply authority for system information.
- The plug shall be accessible after installed the appliance.
- This instruction is subject to change without notice.

[Installation of Accessories]

- Examine carefully the attached packing list and check whether the accessories are complete.
- Users may need to buy at their own expenses the articles not included in the packing list and may be needed in installing.

[Position for Indoor Unit]

- Away from the place where there is heat source, steam source, leakage of flammable gas and smoke.
- No obstacles near the inlet and outlet, and keep good ventilation.
- Good discharge for water.
- At least 3.3ft away from wireless equipment (such as TV, radio etc.).
- Mounted on the wall that can bear the weight of the air conditioner and won't produce noise while unit working.

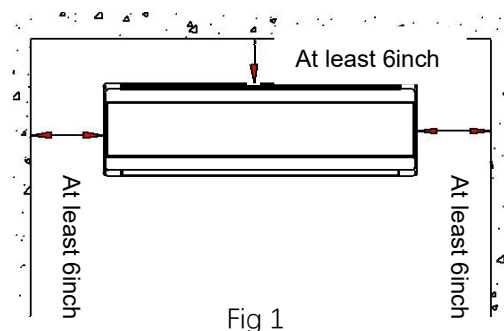

- The distance between the indoor unit and the floor should be greater than 7.5ft.
- The plug shall be accessible after installing the appliance.
- Ensure the distance as required in Fig.1.
- The back of the indoor unit should be close to the wall (Fig.1)
- The all figures are only schematic, and they may be slightly different from the actual appliances you selected.

[Position for Outdoor Unit]

- Avoid direct sunlight.
- Away from heat source, steam source, leakage of flammable gas, smoke and dust.
- Select a place that is away from rain (snow) and has good ventilation.
- Neighbors will not be affected by the blown wind and noise, or discharged water.
- The place that is easy to install and service.
- Mounted on the solid and reliable foundation will not increase noise or shock.
- To get high cooling performance, make sure the unit's front, rear, left and right sides must be located in an open area.
- The outlet is proposed to be in open air, any obstacle will affect the performances.
- The installing distance must be required as Fig. 2 shows.

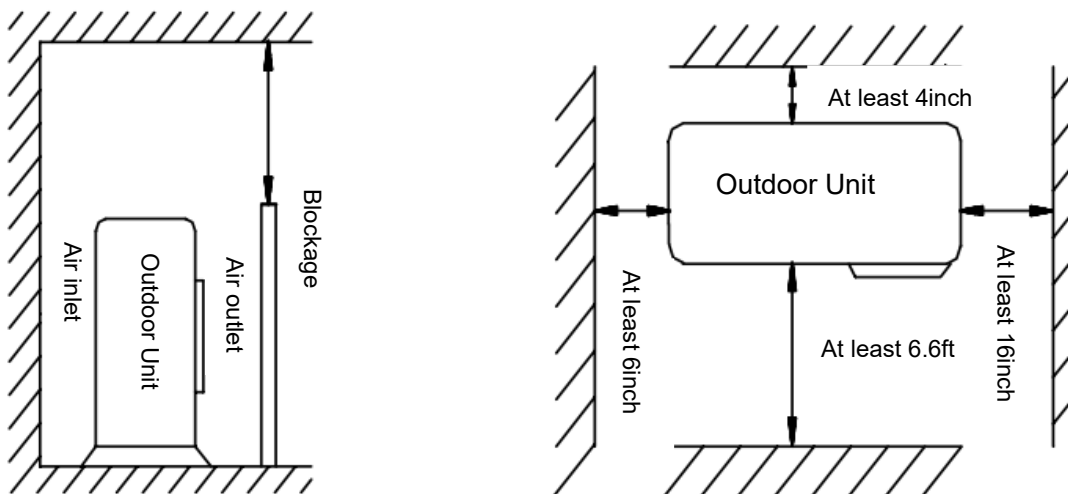

Fig 2

[Tubing Selection]

- Ensure that the level (height) difference of indoor and outdoor units and the length of tubing meet the requirement In the Table 1.
- If the tubing is longer than 23ft, but shorter than 49ft, refrigerant should be supplemented according to Table 1.
- If the installation position of the outdoor unit is higher than indoor unit and the tubing is longer than 33ft, added an oil trap on the gas tubing for every 26ft. (Fig 3)

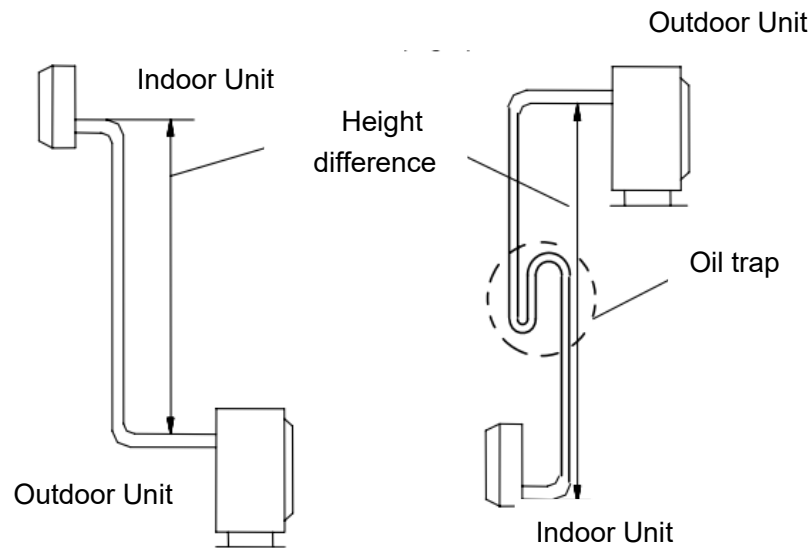

Fig 3

Table 1

Tubing Size (mm/inch)		Standard tubing length (ft)	Max tubing length (ft)	Height difference (ft)	Additional refrigerants (g/.ft)
Liquid tube	Gas tube				
φ6(1/4")	φ9.52(3/8")	16.4	29.5	16.4	39.4
φ6(1/4")	φ12(1/2")	16.4	39.4	23	39.4
φ6(1/4")	φ15.88(5/8")	16.4	49.2	26.3	39.4
φ9.52(3/8")	φ15.88(5/8")	16.4	49.2	26.3	49.2
φ9.52(3/8")	φ19.05(3/4")	16.4	65.6	32.8	49.2

The above dimensions are for reference only, the actual product shall prevail.

[Fixing Installation Panel]

- Dismantle the metal installation board of the indoor unit. Adjust the installation board to horizontal position. The height difference between the left and right sides of the installation board should be less than 0.2inch(5mm). (Fig 4)
- Drill holes and insert plastic expansion tubes at the appropriate locations on the wall and fix the installation board on the wall with M5x30 screws. Ensure that there must be at least 4 fixed points in the wall. Ensure installation board to horizontal position.
- Drill holes as Fig. 5 shows. The hole, 3.2inch in diameter, should slightly slide down outwards.
- Cut PVC tubes at a slight angle in the length shorter than wall thickness and inset it into the hole. (Fig.5)
- Mount the wall cap.

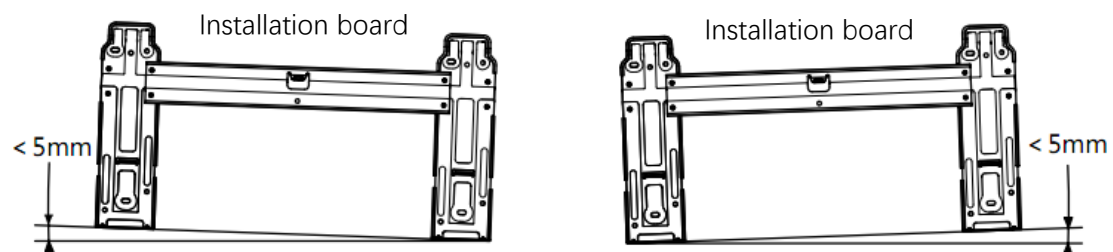

Fig 4

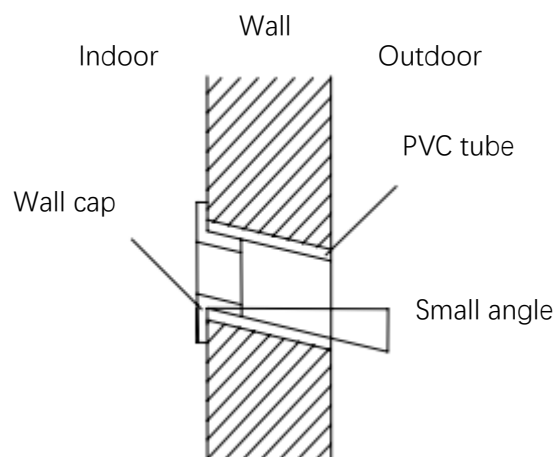
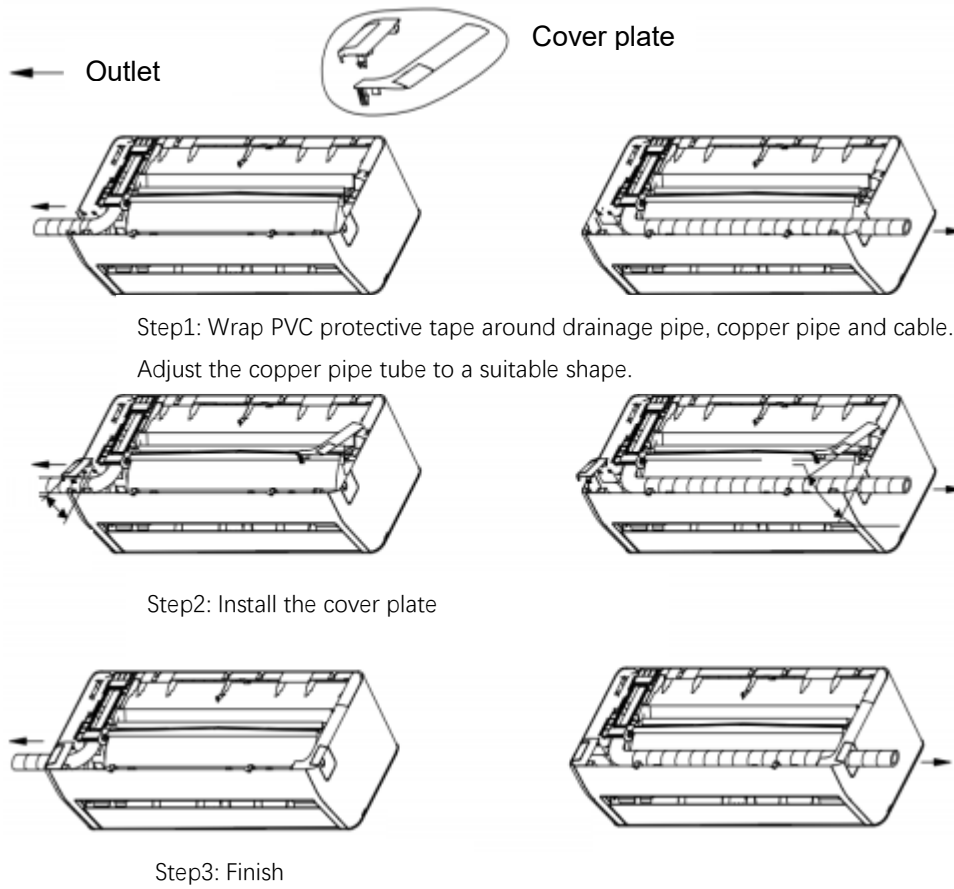

Fig 5

Attachment: installation instructions for decorative cover plate



[Indoor Unit Installation]

The tube may be connected in several directions as below shown Figures.

1. Connecting right back tube (similar to right lower tube) (optional, Refer to Fig.6)

- Pull out the tubing from bottom of the chassis; and connect the drainpipe. Strap the joint of tubing reliably.
- Lead the connecting wire to the indoor unit (Do not connect to the power).
- Strap together the tubes, discharge pipe and connecting wire with adhesive tape. The discharge pipe is put at the below.
- Remove the board which is on the chassis.
- Check if the connections are reliable.
- Mount the indoor unit on the two hooks at the upper part of installation board. (Refer to Fig.8)

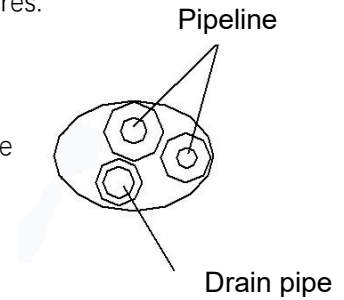

Fig 6

2. Connecting left back tube (similar to left lower tube). (optional, Refer to Fig9)

- Move the discharge tube to the left side, and discharge cap to the right side.
- Fix the tubes in the slot of the indoor unit with the fix clamp.
- The following mounting steps are the same as those in "1. Connecting right back tube."

Notes: Left chart is available for the position of drain hose, refer to Fig 7.

Right chart is available for the position of drain hose, refer to Fig 9.

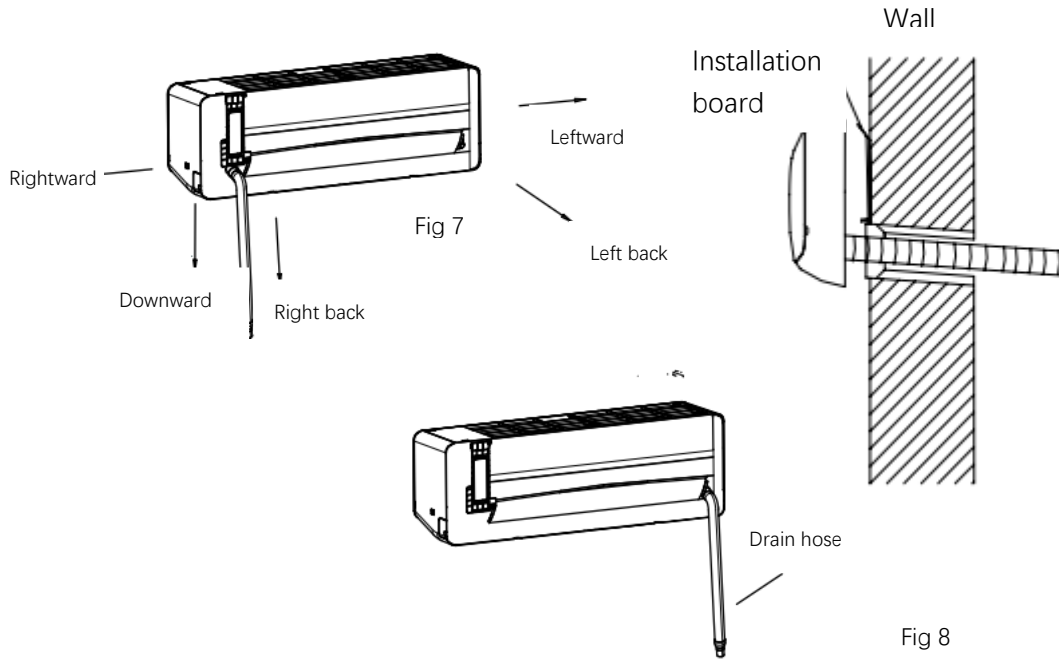

Fig 9

Fig 8

[Outdoor Unit Installation]

- If installation brackets for installing outdoor unit are needed, user could buy the brackets from our company or agents (Fig.10) .
- Assemble the mounting frame and supports with the attached 6 screws (M12x25), plain washers, spring washers, and nuts.
- Drill 4 or more holes on the wall according to the feet size of the air conditioner. Determine the locations for mounting left and right supports. Ensure that the left and right supports are on the same level.
- Fix installation frame on the wall with expansive bolts.
- Fix outdoor unit with 4 bolts (M10x25) on the installation brackets.
- Fittings must be tightly screwed; Connection must be tight and reliable.
- In installing outdoor unit, the body should be hung with ropes to prevent from falling.
- In installing or repair, tools and components should be prevented from falling.
- Regularly check the reliability of the installation frame.

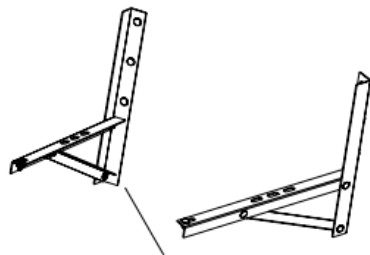

Fig 10 Installation support

[Tubing Connection]

- Detach the valve cover of outdoor unit.
- Align flaring nut to the thread center, and screw the nut tightly by hand.
- Screw tightly the flaring nut with torque spanner until the torque spanner produces "click" sound.
- It is recommended to use torque spanner to connect the tubing. If other flexible or fixed spanner is used, it may damage the horn mouth due to improper force.
- The bending angle of the tube should not be too small or the tube may break up, so the service personnel should use tube bender to bend the tube.
- Never let water, dust or sand gets into the pipe.

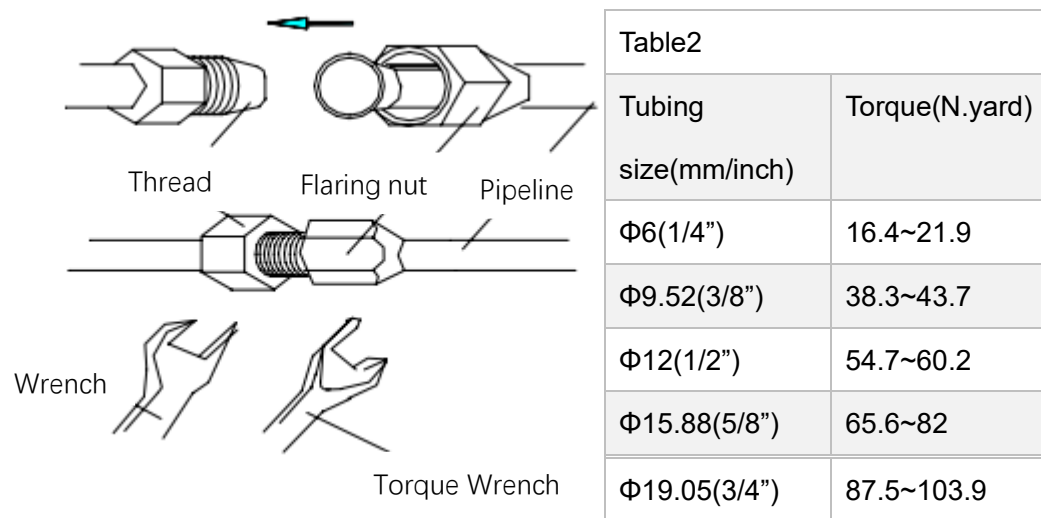

Fig 11

[Connection of Wires]

1. Indoor unit (fig.12)

- Open the panel upwards and open directly to the maximum.
- Open the electrical cover.
- Secure the connection wires to the terminal block according to the wiring diagram on the electrical cover.
- Press the connecting wire tightly with the pressure plate.
- Close the electrical cover, secure the electrical cover with screws, and close the panel.

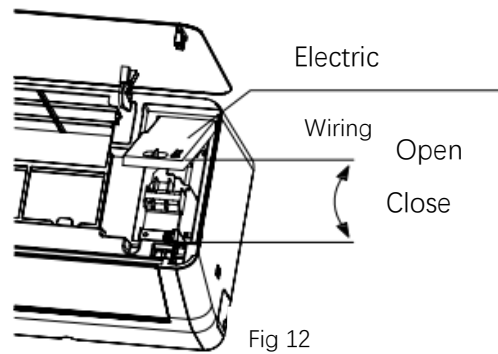

Fig 12

Note: Some models may not be able to directly pass through the cable hole into the electric control box, and the above steps need to be removed after removing the middle frame.

2. Outdoor unit (fig.13)

- Unscrew the handle cover fixing screw and open the handle cover.
- Secure the connection wires to the terminal block according to the wiring diagram on the handle cover.
- Press the connecting wire tightly with the pressure plate.
- Put the handle cover back and fasten with the screws.
- If customers need to extend or replace the power cord, please refer to Table 3 for specifications.

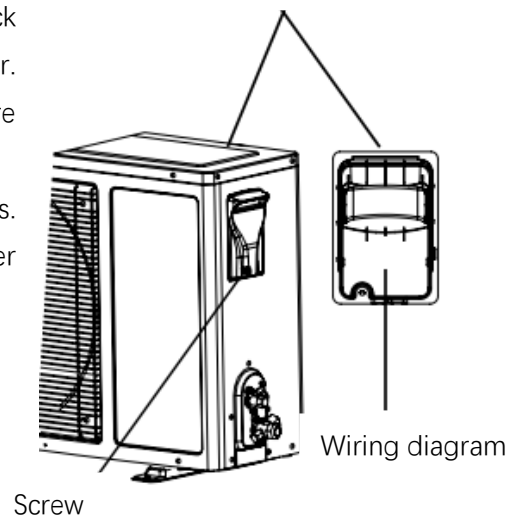

Fig 13

Table 3

		Power connecting wires	Sign control wire	Power cord
	Max Length	11yard	11yard	5.5yard
5K/7K/9K/12K	Cross sectional area	$\geq 0.00155\text{inch}^2$	$\geq 0.00155\text{inch}^2$	$\geq 0.00155\text{inch}^2$
16K/18K		$\geq 0.00233\text{inch}^2$	$\geq 0.00233\text{inch}^2$	$\geq 0.00233\text{inch}^2$
18K/21K/24K/28K		$\geq 0.00388\text{inch}^2$	$\geq 0.00116\text{inch}^2$	$\geq 0.00388\text{inch}^2$
9K/12K (115V)		$\geq 0.00233\text{inch}^2$	$\geq 0.00233\text{inch}^2$	$\geq 0.00233\text{inch}^2$

Connecting diagram for 12K,18K.

Signal wiring for indoor unit and outdoor unit 12,000 BTU 115V

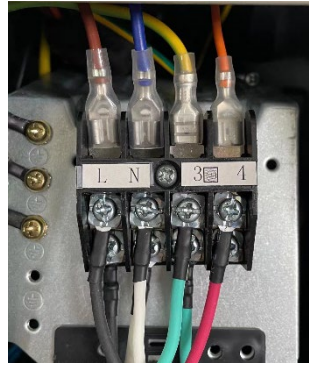

Signal wiring for indoor unit and outdoor unit 18,000 BTU 230V

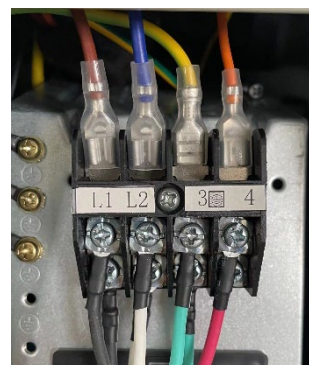
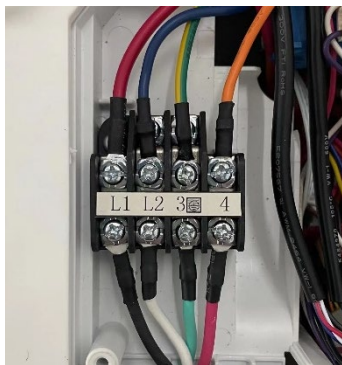

Notes:

- Earthing screw must use special screw (stainless machining screws or copper screws M4)
- Ensure that all wires are securely connected, will not loose or separate.
- Ensure that wire connections are carried out according to the wiring diagram of the air conditioner.
- The above figures are only schematic, and they may be slightly different from the actual appliances you select.

Tube Strapping

- Strapping with PVC Protective tape must be careful, do not damage the pipeline and drain pipe.
- Strapping should start from the lower part of the outdoor unit to the indoor unit.
- Fix the PVC tape with adhesive tape to prevent loosing.
- Drainpipe should slightly slide down outwards to ensure drainage well.
- When the indoor unit is lower than the outdoor unit, bend the tube to proper extent to prevent water draining into house.
- Fix the tube bundle with tube clamps on the wall.
- Allow enough space between discharge pipe and the ground. Do not put the discharge pipe in water or ditch.
- Seal the external wall holes with sealing gum or putty.

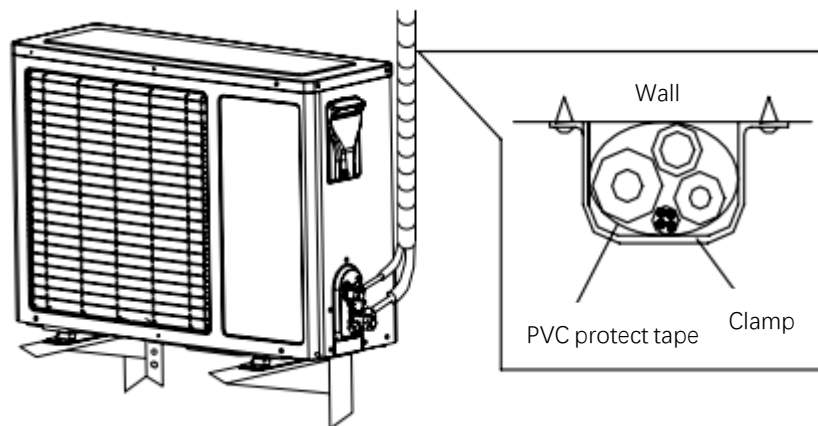

Fig 14

Exhaust

- Make sure that all the tubes of indoor and outdoor unit are connecting well.
- Take off valve bonnet from two-way and three-way valves by spanner; connect vacuum pump and compound valve to the service valve bonnet.
- Open the low-pressure switch of compound valve, and run vacuum pump until units' internal pressure at 10 mmHg.
- After pump vacuum, close the low-pressure switch of compound valve, and then close vacuum pump. Turn anti-clockwise 90° Spool of narrow pipe service valve by hexagon spanner, tightly with clockwise turning after stopping for 10 seconds.
- Check with soap water or leak detector whether there is leakage at all connections of indoor and outdoor unit.
- Open wide and narrow pipe service valves by hexagon spanner for running.
- Take off the connection pipeline of wide pipe service valve.
- Screw tightly the entire valve bonnet by torque spanner.
- Check with soap water or leak detector whether there are leakage at all indoor and outdoors' connections.
- Put the valve bonnet and lid back to position.

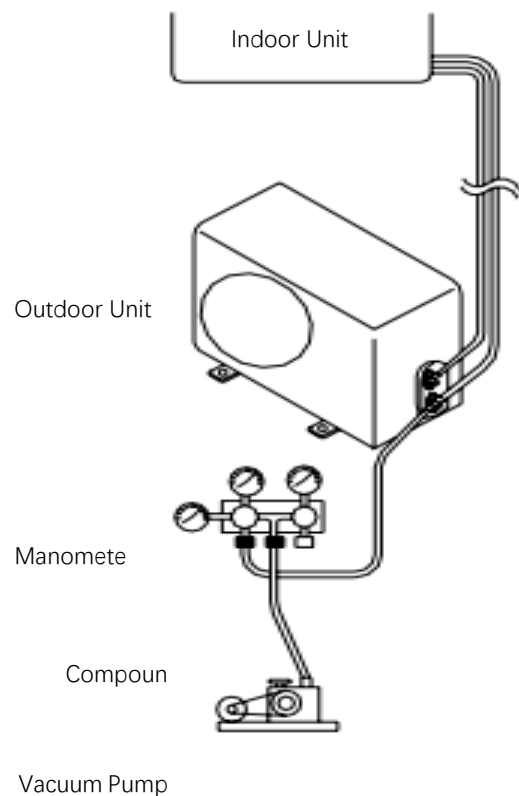

Fig 15

[Drainage]

1. No need drainage treatment

In regions where become cold in the winter, don't install the drain elbow joint to prevent drain water from freezing and causing the fan to be damaged. This drainage treatment is not necessary for cooling-only type air conditioner.

2. When need drainage treatment

Please use drain elbow joint (in accessory bag). Outdoor unit should be placed on blocks.

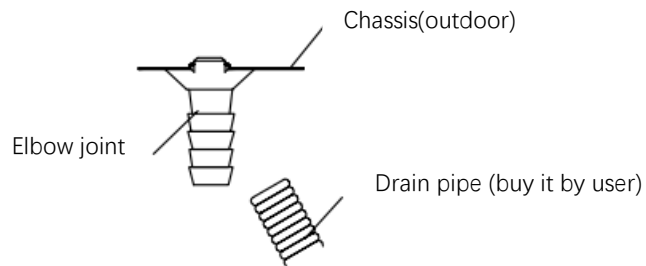

Fig 16

Installation for the cover of valve

For the whole unit that individual cover of valve is available (refer to packing list), the installing method is as follow:

After connecting the connection pipes between indoor and outdoor units followed by the installing method mentioned above, take out the cover of valve from the accessory bag, and fix it on the side of outdoor unit with three corresponding screws. (inside the accessory bag)

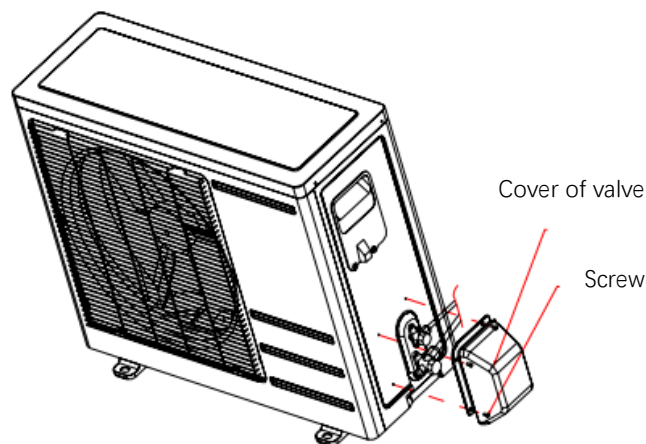

Fig 17

Product Introduction

[Protect Functions]

Protect functions can prolong the air conditioner's service life and provide more comfortable airflow.

Delay-starting protection for the compressor

The compressor will restart working at least 3 minutes (5 minutes in heating mode) after being turned off to keep the pressure balance of the cooling system.

Remarks: There will be 1 minute for the compressor to work after the unit is electrified for the first time.

Defrosting (not available for cooling-only type air conditioner)

The outdoor heat exchanger may frost if the outdoor temperature is low and humidity is high. In this case, auto-defrosting has operated for 3~10 minutes. pause indicator will be on, indoor and outdoor fan stop.

Heating overload protection (not available for cooling-only type air conditioner)

When the temperature of indoor pipe is too high, air conditioner enters heating overload protection. And indoor fan speed should be adjusted to a higher gear automatically. Outdoor fan and compressor may be stopped. When indoor pipe temperature drops to a rated value, air conditioner will exit heating overload protection. Indoor fan motor resumes to the normal status.

Blowing residual heat function (not available for cooling-only type air conditioner)

Indoor fan will keep running at low fan speed for 80 seconds when air conditioner is stopped in heating mode.

Heating airflow prevention (not available for cooling-only type air conditioner)

In the first several minutes of heating operation, the display screen will flash; indoor fan doesn't run and louver blades can't be controlled. About 5 minutes later, air conditioner will blow heat airflow.

Freeze-prevention

To prevent indoor heat exchanger freezing in cooling and dehumidification operation, compressor or outdoor fan may stop running; indoor fan speed will be adjusted to a higher gear automatically.

Dry for enzyme-prevention (optional)

Indoor fan motor will go on running for 3 minutes at low fan speed when turned off in cooling mode in order to keep dry condition inside the unit.

Reset power or auto restart (alternative)

Reset power: When there is a power suspension, air conditioner will automatically switch off. When the power is back, the unit will automatically reset power. For energy saving if there is no person in the room, air conditioner will stay in PAUSE status. User needs to turn on Air conditioner by remote controller.

Auto restart: The unit memories the operation mode, air flow setting, temperature setting etc., so that should there be a power failure when the unit is in operation, it will automatically return the same operating conditions when the power is restored.

Description of Components



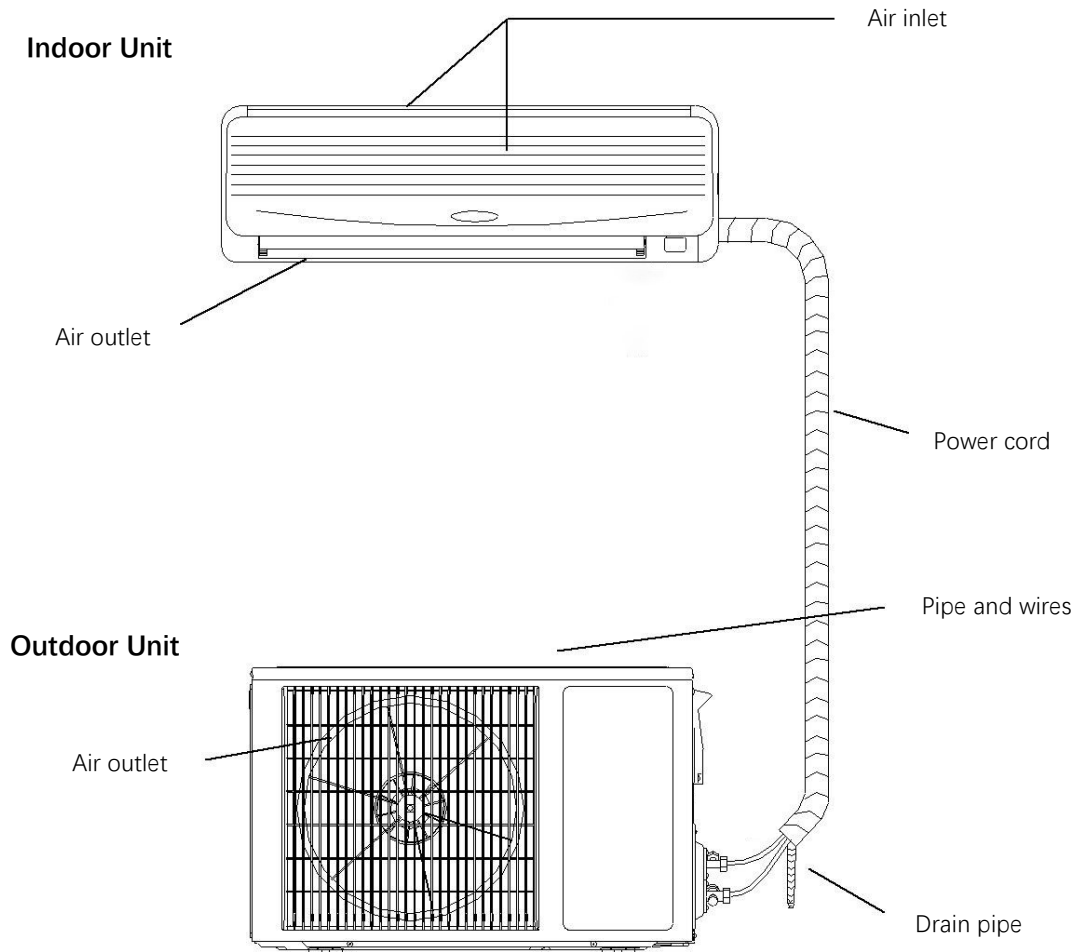

[View of Unit]



Remarks:

The air conditioner is consisting of indoor unit, outdoor unit and remote controller. The design and shape are different for different models. The above figures are only schematic, and they may be slightly different from the actual appliances you selected.

[Display Screen]

	The display can show the set temperature, error codes or timing time.
	This signal light is on when the unit is in timer.
	This signal light is on when the compressor is running.
	Flashing on behalf of searching, lighting on behalf of WIFI completed connection, which means WIFI function can be operation and application. (For more details, please refer to the WIFI instruction manual)
	This signal light is on when the unit is in health function.

Note: The above LED display is for reference only, subject to the actual product.

[Remote Controller]

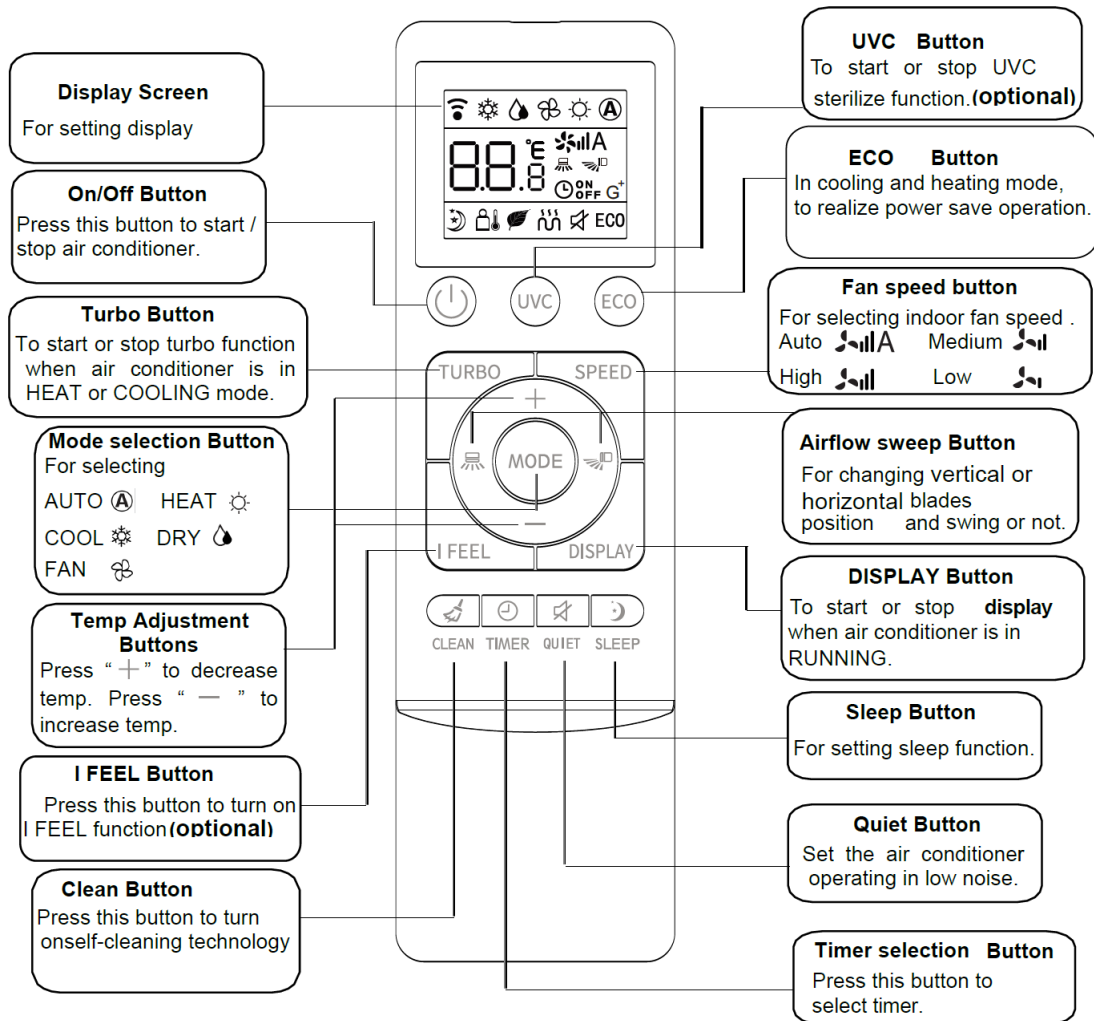

Remarks:

1. The function and display of Heat is not available for cooling-only air conditioner.
2. HEAT, AUTO function and display are not available for cooling-only type air conditioner.
3. If user want to make the room air cool or warm quickly, user can press “turbo” button in cooling or heating mode, air conditioner will run in power function. If press “turbo” button again, air conditioner will exit power function.
4. The above illustration of remote controller is only for reference, it may be slightly different from the actual product you selected.
5. **Hold button “+” and “-” to switch Fahrenheit and Celsius.**

[Remote Controller Display]

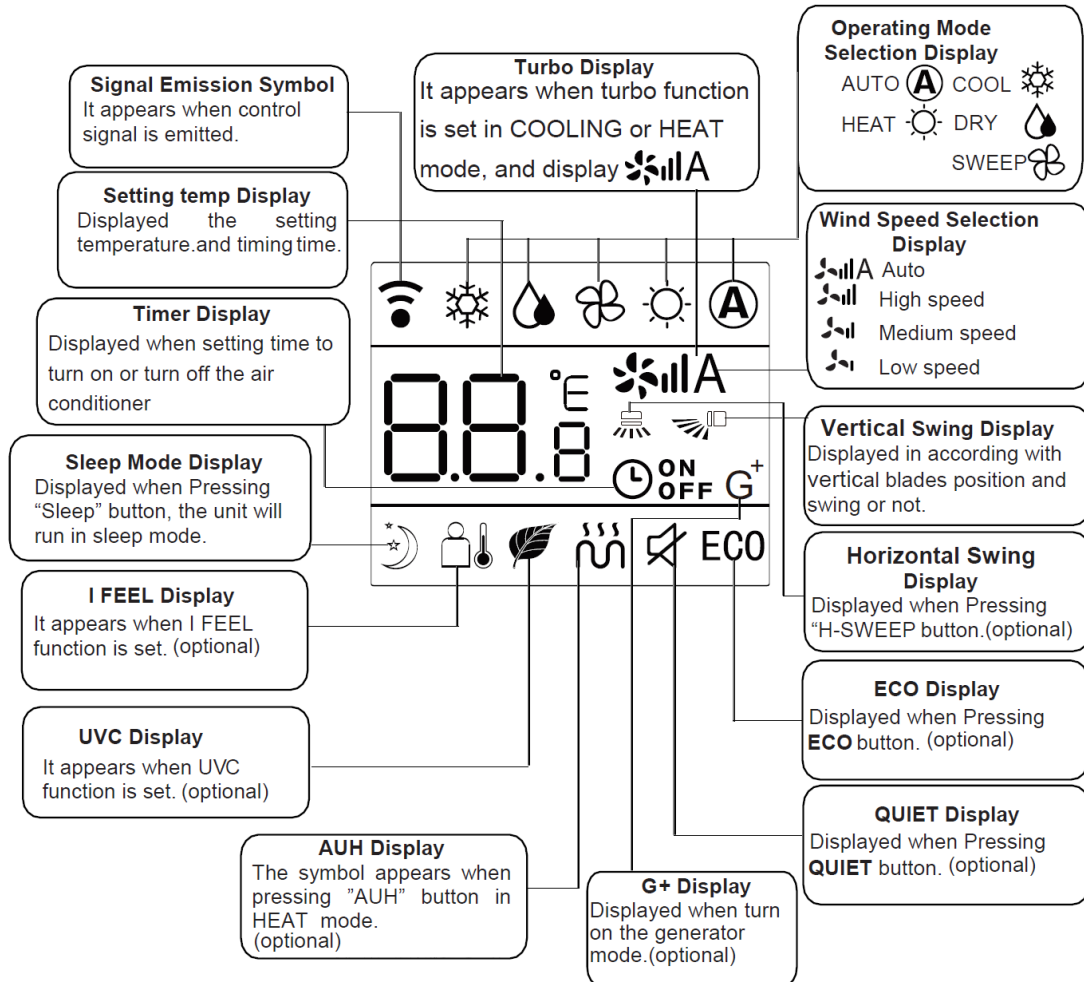

Instruction for remote controller

The remote controller uses two AAA alkaline batteries under normal condition, the batteries last for about 6 months. Please use two new batteries of similar type (pay attention to the poles in installing).

When using remote controller, please point the signal emitter towards indoor unit receiver; There should be no obstacle between remote controller and indoor unit.

Pressing two buttons simultaneously will result wrong operation.

Do not use wireless equipment (such as mobile phone) near indoor unit. If interference occurs because of this, please switch off the unit, pull out power plug, then plug again and switch on after a while.

There is no direct sunlight to the indoor receiver, or it can not receive the signal from the remote controller.

Don't cast the remote controller.

Don't put the remote controller under the sunlight or near the oven.

Don't sprinkle water or juice on the remote controller, use soft cloth for cleaning if it occurs.

The batteries must be removed from the appliance before it is scrapped and that they are disposed of safety.

Service and Maintenance

Careful maintenance and overhaul in advance can prolong the air conditioner's service life and save electricity charges.

Caution:

1. Stop air conditioner by remote controller and pull off the plug before service and maintenance.
2. Do not stand on unstable objects when you clean or service air conditioner, or it may cause personnel injury.
3. Do not touch the metal part of the body when you remove the front panel, or it may cause personnel injury.



[Clean the Front Panel and Remote Controller]

If the dirt can't be removed, please clean it with warm damp cloth (soaked with warm water below 40°C)

Caution:

1. Do not clean the unit with water, or it may cause electric shock.
2. Do not clean the remote controller with water.
3. Do not clean with alcohol, gasoline, banana oil, or polishing.
4. Do not clean the unit violently, or it may cause the front panel falling down.
5. Do not clean the front panel or remote controller with metal brush; it may damage the surface.



[Clean Air Filter]

1. Open the front panel.
2. Lift the protruding part, then pull it downward, remove the air filter.
3. Clean it with vacuum cleaner or water. If air filter is very dirty, please clean it with warm soapy water or mild detergent. Then dry it in the shadow.
4. Insert air filter into the previous position, and close the front panel.

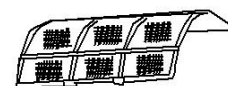

Note:

1. Air filter should be cleaned at least once every two weeks, or heating or cooling capacity will be reduced.
2. Do not clean the air filter with metal brush, it may be damaged.

[No Use for Long Time]

Swing 3-4 hours to dry the internal air conditioner.
Stop operation by remote controller, then cut off the power source of air conditioner.
Maintain air filter net.
Take out batteries from remote controller.

[Recommendations for Energy Saving]

Appropriate Temp Setting	It is harmful to health if the room is too cold.
Avoid Direct Sunlight	When it is cooling, please use curtain or blind to obstruct direct sunlight.
Avoid Heat Sources	When it is cooling, using other heat sources may affect cooling effect.
Close Doors and Window	Incoming outdoor air will affect the cooling or heating efficiency.
Keep Air Filter Clean	Keeping air filter clean ensures high efficiency operation.
Good Ventilation	Do not put objects in front of the inlet and outlet of outdoor unit.

[Normal Phenomenon]

When it is heating or cooling, plastic substance may give out a sound because of the temperature change.
If the indoor humidity is too high, water drops may form on the front grill of indoor unit. This is a normal phenomenon.
There may be gentle "rustle" sound when the unit starts or stops. It is the normal sound of flowing refrigerant.
Walls, carpet, furniture or clothes indoors may disseminate peculiar smell.
In order to protect the unit, when the compressor stops, there will be a 3-minute delay before restarting.
In the first several minutes of heating operation, wind may not come out from the indoor unit.
Water may flow out from the outdoor unit during heating operation.
In heating operation, steam may come out when it is defrosting.

Trouble Shooting

[Air Conditioner is in Error]

Checking before service.

Phenomenon	Checking Items
Air conditioner do not operate at all	1.Check whether the power is disconnected.
	2. Check whether the breaker is switched on or the fuse is burnt.
	3. Check the remote controller batteries.
	4.Check whether radio equipment is used within 1m around the unit.
Poor cooling or heating performance	1.Check whether the air inlet or outlet is blocked.
	2.Check whether dust is blocking the filter.
	3.There may be too many people indoors.
	4.Check whether doors or windows are closed.
	5.Check whether fan speed or set temperature is improper.

[Remote Controller is in Error]

The following trouble shooting is normal phenomenon.

Phenomenon	Checking Items
Fan stops or fan speed can't be controlled	1. When air conditioner is in dehumidification mode or sleep mode, fan speed can't be controlled sometimes.
	2. When air conditioner is in cool airflow proof or defrosting operation (heat mode), fan motor will stop.
	3. When air conditioner is in cool or dehumidification mode, if air conditioner enters freeze-prevention operation, then fan speed can't be controlled.
	4. When air conditioner is in heat mode, if air conditioner enters heating overload prevention operation, then fan speed can't be controlled.

TROUBLESHOOTING & WARRANTY

BEFORE YOU CALL FOR SERVICE

IF THE AIR CONDITIONER FAILS TO OPERATE

- A) Check to make sure that the air conditioner is plugged insecurely, if it is not, remove the plug from the outlet, wait 10 seconds and plug it in again securely.
- B) Check for a blown circuit fuse or a tripped main circuit breaker. If these seem to be operating properly, test the outlet with another appliance.
- C) Check if electricity to the main power switch of the unit appears to be working.
- D) Make sure that both units are in the upright position.

IF NONE OF THE ABOVE SOLVES THE PROBLEM, CONTACT A QUALIFIED TECHNICIAN.

⚠ WARNING: DO NOT TRY TO ADJUST OR REPAIR THE AIR CONDITIONER YOURSELF.

CUSTOMER SERVICE

IMPORTANT

If you have a problem with this product, please contact the below

DATED PROOF OF PURCHASE, MODEL # AND SERIAL # REQUIRED FOR WARRANTY SERVICE

Customer & Technical Support information
(Please contact us BEFORE returning product)

Website: www.bhiair.com

Contact Phone #: 1-626-427-3298

(Mon-Fri: 9am-5pm/PST)

Email: support@bhiair.com

help@bhiair.com

12,000 BTU/18,000 BTU Ductless Mini Split Air Conditioner with Heat Pump



INSTRUCTION MANUAL

Wi-Fi Feature is only available for Wi-Fi enabled model

1. Instruction

Smart air conditioner is an air conditioner with Wi-Fi remote control system. It could be controlled by your smartphone with 2.4G Wi-Fi, 2G, 3G ,4G network.

1.1 Power off the air conditioner, Open the air conditioner panel as shown in the figure.



1.2 Unscrew WiFi box screws.



1.3 Insert WiFi module as shown in the figure (The “Smart kit” is marked face up)

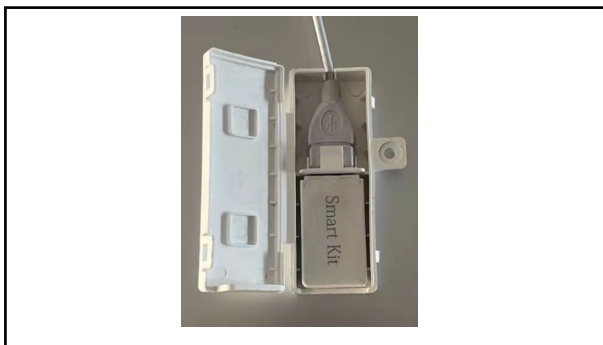

2. App download link

Address : <http://e.tuya.com/smartlife>



Scan the QR code to download Smart App

Note: After the initial installation of iOS version, may be prompted to remind, as shown below. Go to Phone Settings - General – Profiles & Device Management, tap on “Hangzhou Miaoyong Technology...” - “Verify Apps”, and select “Verify”. Then open App again



3. Operation instruction

3.1. Register account:

When you open the App for the first time, start your registration. Tap on "Register" at upper right corner of the login page, Type in your Email address or mobile number,

tap on “Next” and receive a verification code. Type in the code and confirm your password, and then tap on “Confirm”. After successful verification, registration process is finished and App goes to the home page.

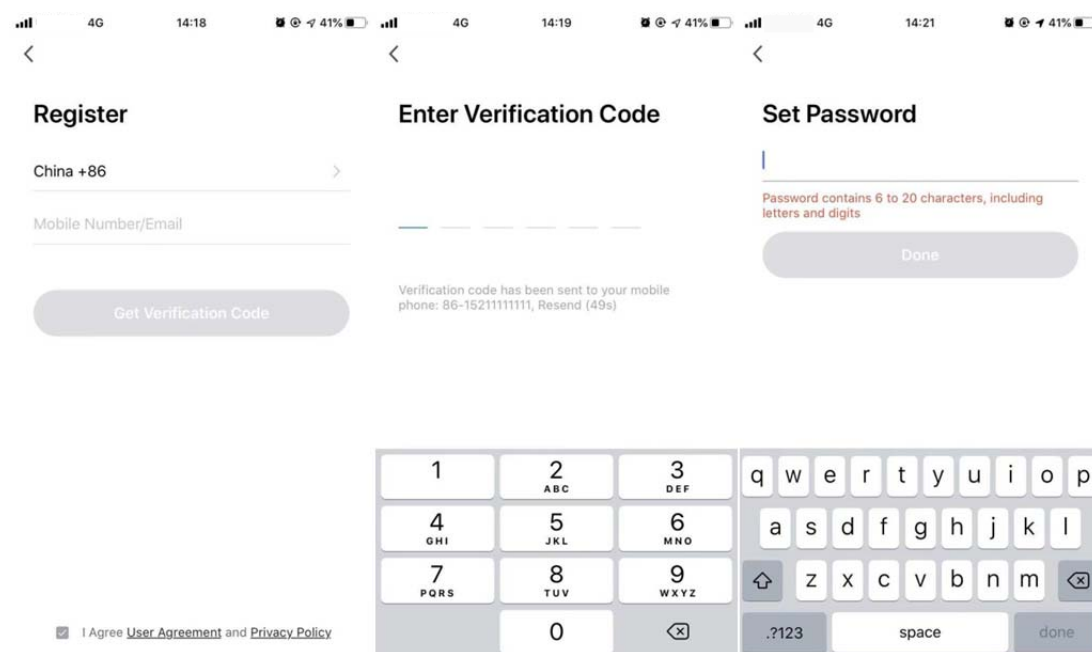

3.2. How to add device?

3.2.1 Please make sure that the device is on the pending status awaiting to be connected. If not, please reset the device via the following procedures: Long press the reset-button for 5s — buzzer sounds — the WIFI icon on device is quickly flashing (approx. 3 times/s). Then it indicates that the device is successfully reset and has entered into Smart mode.

3.2.2 Open the App, tap on **【Add device】**, select your own Wi-Fi network, type in your own Wi-Fi router password and tap on “Next”. Then the network configuration starts.

3.2.3 When configuration is successful, you could see the app interface as shown in the screenshot below.

3.2.4 Tap on **【Done】**, you could see the interface of a device list as shown in the screenshot below.

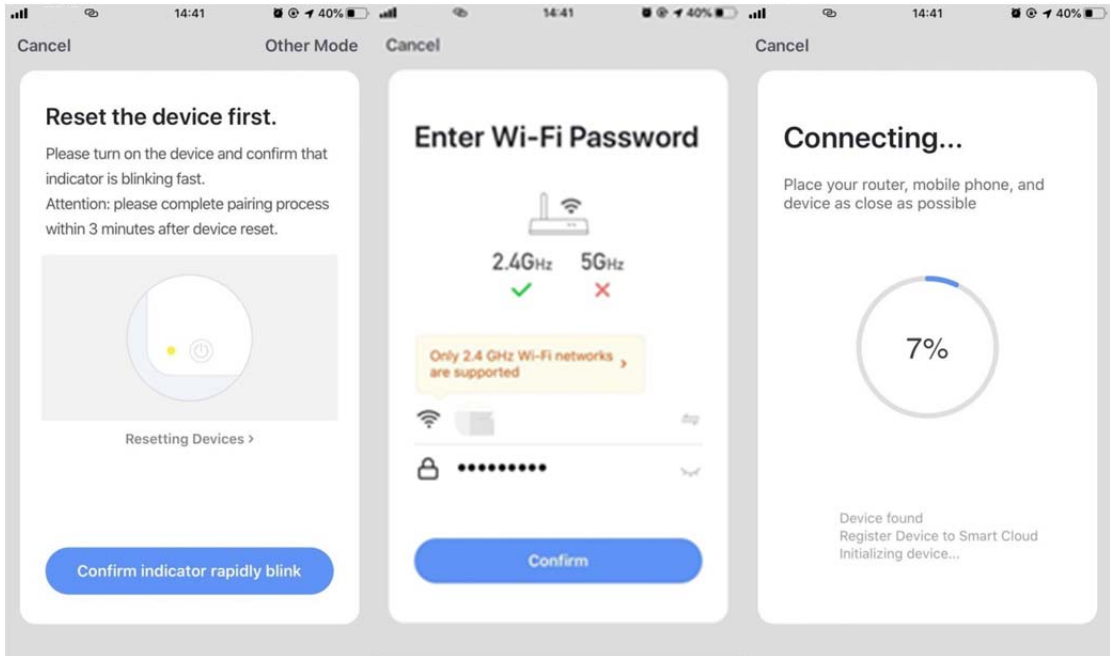
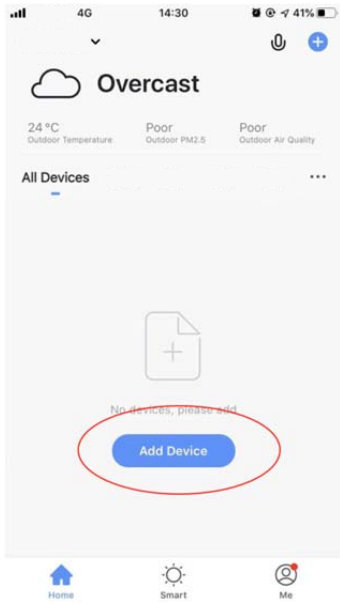

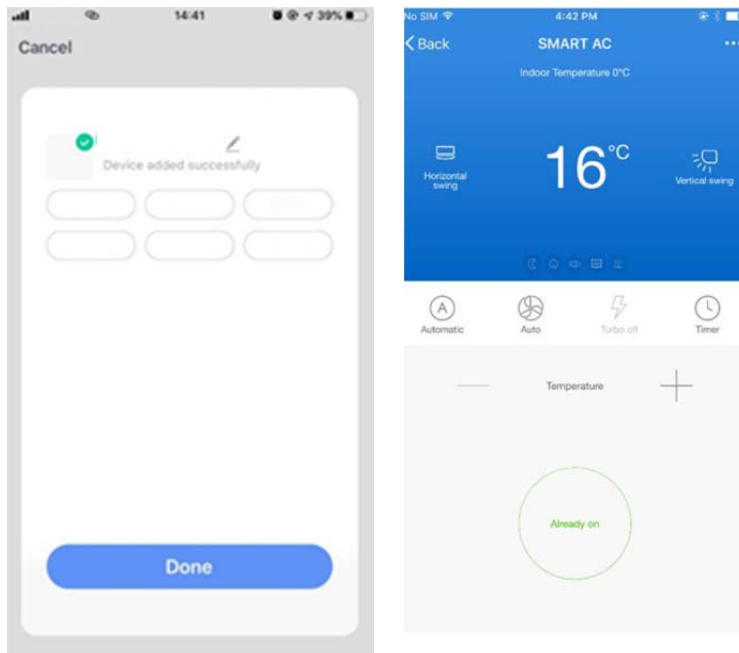

3.3. What if connection failed?

When the connection failed, you could see the the App interface as shown in the screenshot below. Please try to configure network again or switch to AP mode.

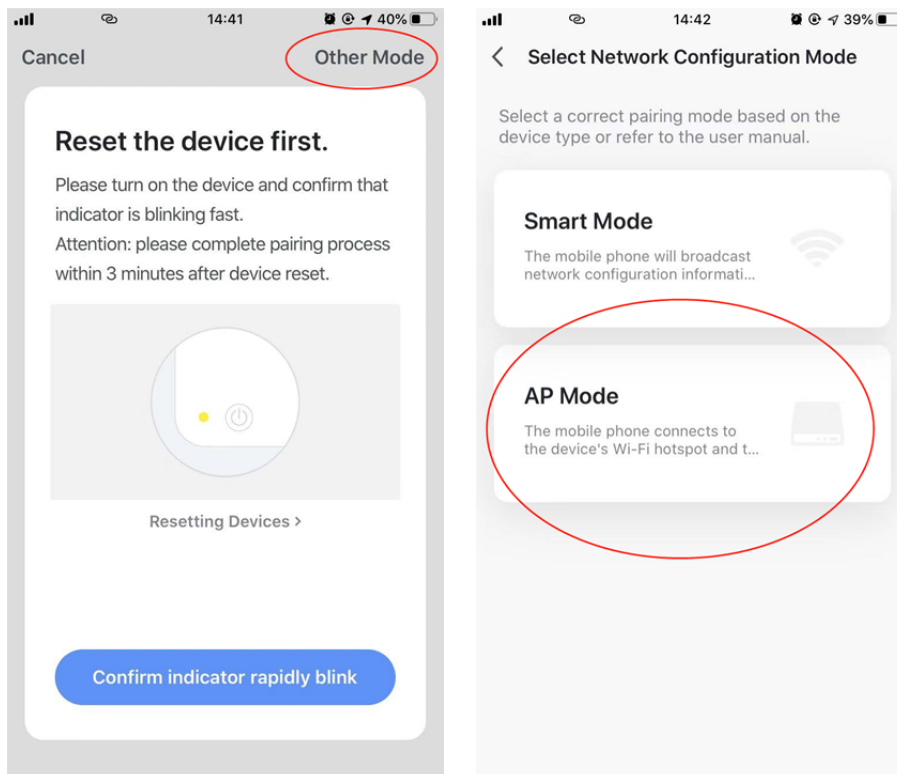

3.3.1. Continue to connect by switching other connection mode.

1. Tap on【AP mode】 , configure network via AP mode with the following procedures.
2. Switch Air conditioner to AP mode: When it is under smart mode, long press reset-button for 5 seconds-buzzer sounds—the heating icon on device is slowly

flashing (approx. 1.5 times/s). It indicates the Air conditioner has entered into AP mode

3. Connect to device hotspot: Tap on **【Connect】** (open phone settings-WLAN), connect to the hotspot named “SmartLife-XXXX” (The name of WIFI may vary, depending on the actual product), then the network configuration starts as shown in the screenshot.

4. After successful network configuration, tap on “Done” and the device list interface appears.

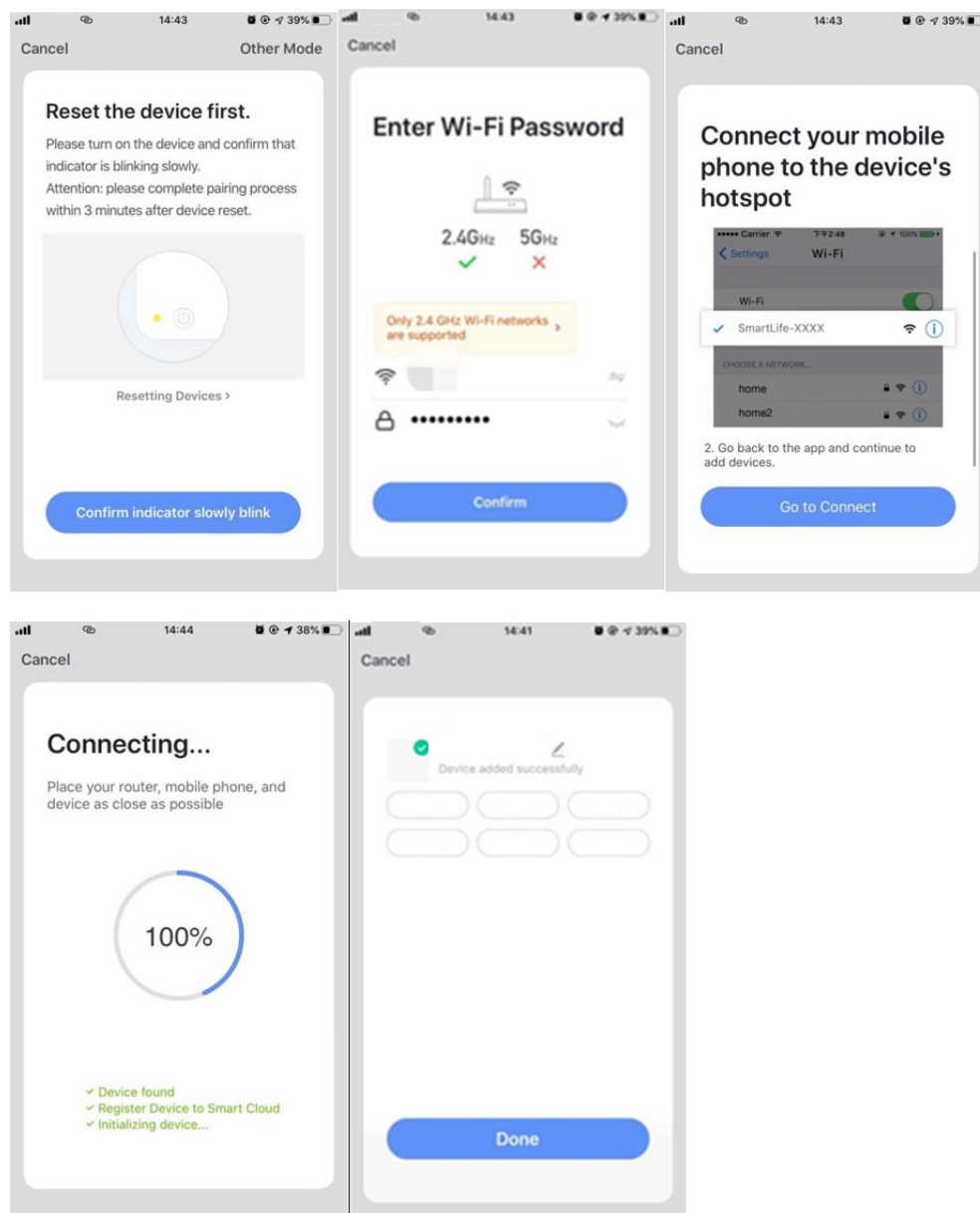

3.3.2. Add device again from device list

1. Open App, tap on **【AP mode】** at upper right corner, connect to device via AP mode with the following procedures.

2. Select your own Wi-Fi network, type in your Wi-Fi router password, and tap on “Next”

3. Switch Air conditioner to AP mode: When it is under smart mode, long press

reset-button for 5 seconds-buzzer sounds— device’s indicator light is slowly flashing (approx. 1.5 times/s). It indicates the Air conditioner has entered into AP mode

4. Connect to device’s hotspot: Tap **【 Connect 】** (open phone settings-WLAN), connect to the hotspot named “SmartLife-XXXX” (The name of WIFI may vary, depending on the actual product), then the network configuration starts as shown in the screenshot.

5. After successful network configuration, tap on “Done” and the device list interface appears.

3.4. Device control

3.4.1 Select the device and enter the main control interface as shown in the screenshot below.

3.4.2 Tap on **【Switch】** to turn on/off Air conditioner

3.4.3 Tap on **【Mode】** to switch the working mode

3.4.4 Tap on **【Speed】** to control the wind speed

3.4.5 Tap on **【Left-right swing】** to turn on/off left-right swing function

3.4.6 Tap on **【Up-down swing】** to choose the wind direction such as swing, direction 1, direction 2, direction 3, direction 4, direction 5 and etc.

3.4.7 Tap on **【Multiple functions】** to select more functions such as sleep, air freshening, electrical heating. “Display” function is to turn on/off the display screen of air conditioner.

3.4.8 Tap on **【Timer】** to automatically turn Air conditioner on/off at a specific time.

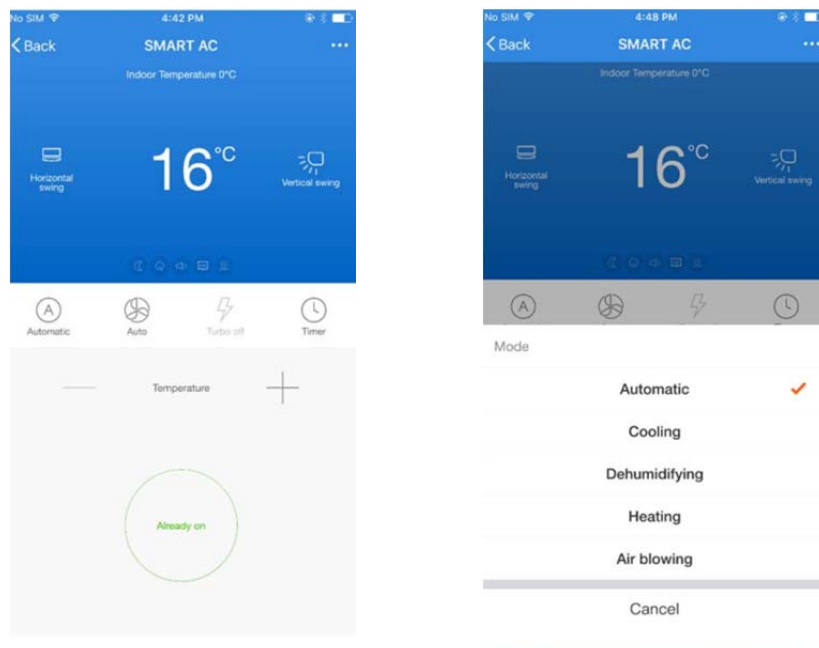

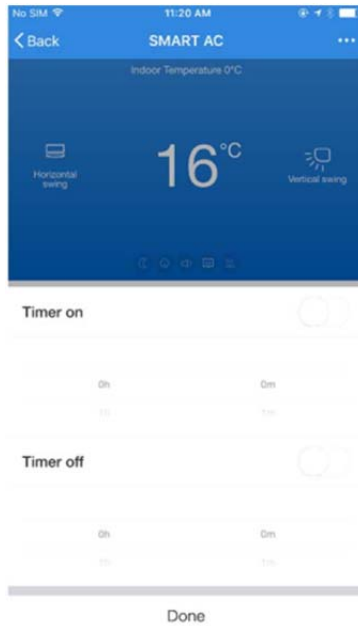
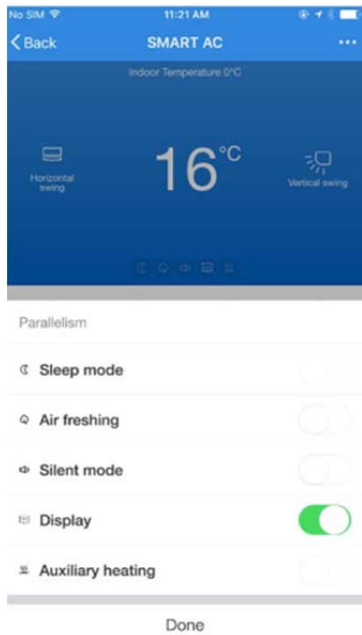

3.5. Modify device name

Tap on upper right corner of the main control interface, select **【Modify】** , type in the new device name on the pop-up dialog, and tap on **【Save】** .

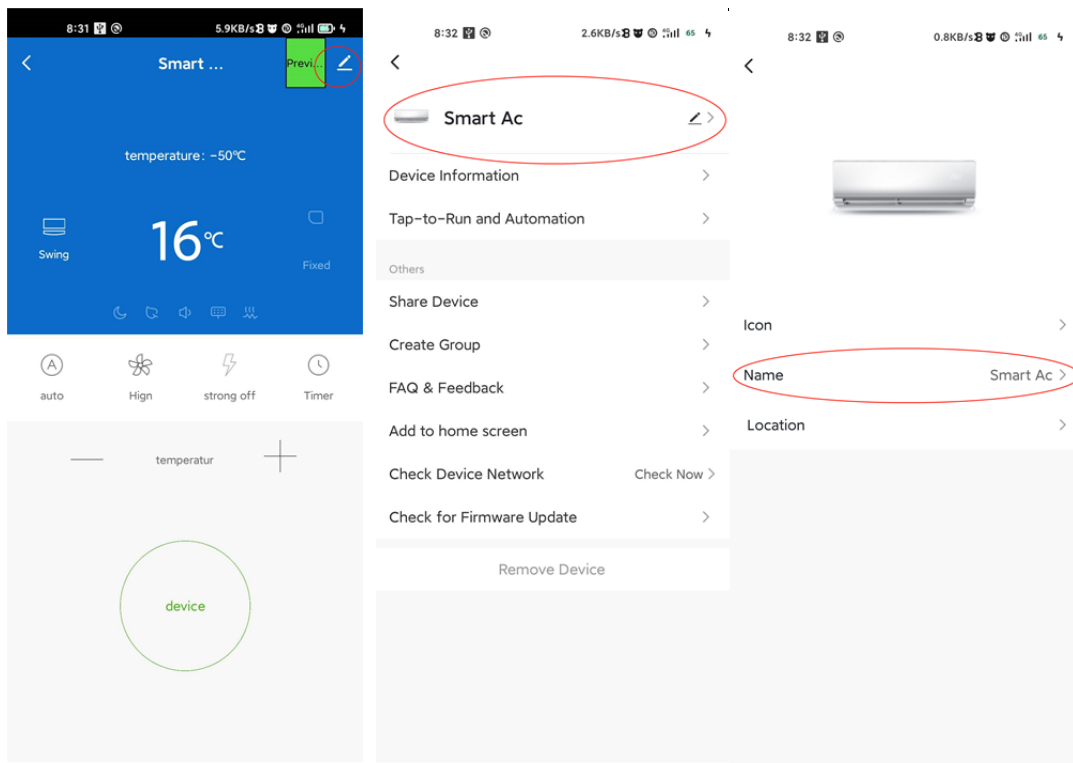

3.6. Delete device or Reconnection

3.6.1 Tap on upper right corner of the main control interface, select **【Remove device】** , the dialog pops up to notify you whether to remove device. Tap on **【Confirm】** , device will be removed from the App and switched to reset status.

3.6.2 Long press the reset-button for 5s— buzzer sounds— the WIFI icon on device is quickly flashing, It will force an existing connection to be disconnected and needs to be re paired.

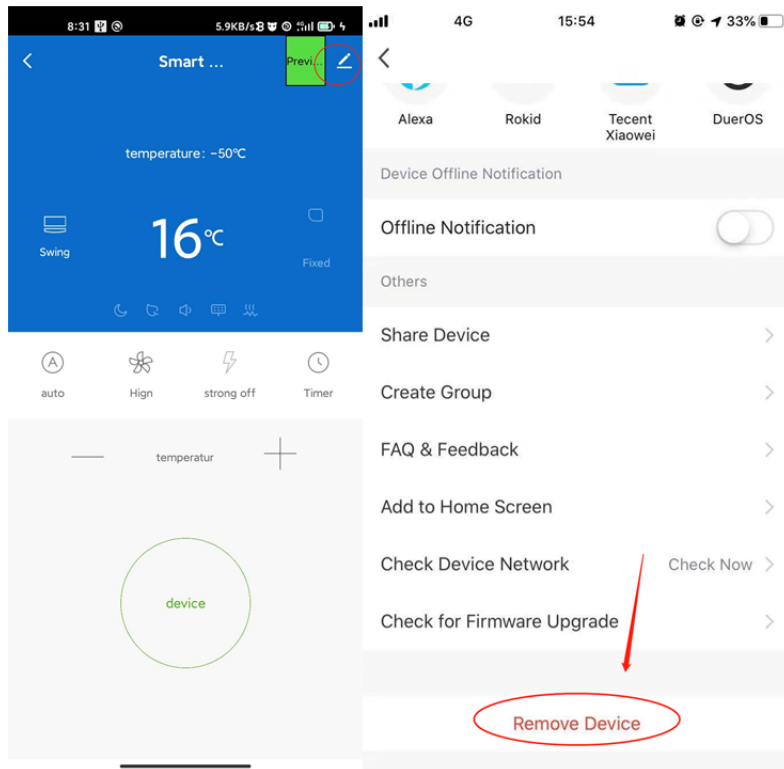

3.7. Share device

Tap on **【Home Management】** , select **【Home name】** - **【Add Member】** ,input the account you want to share.

in other's account number, tap on **【Confirm】** . The person would receive the sharing settings and easily control the device with smartphone App.

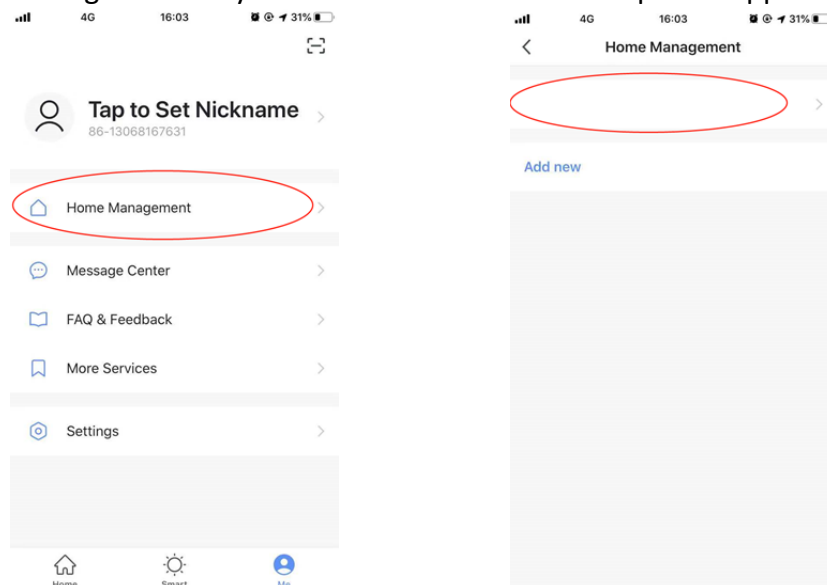

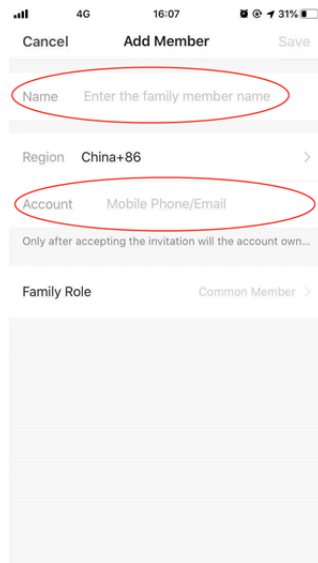
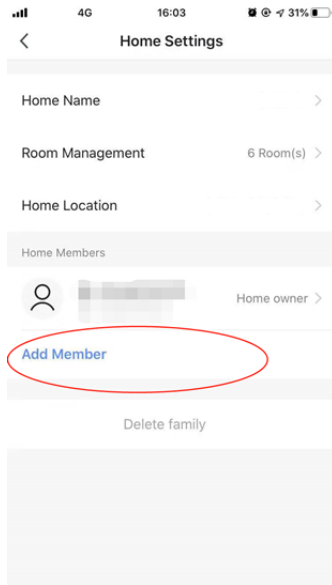

Remarks: If you sign in with a third-party account (Email address, Facebook and Twitter), you need to bind to your mobile number in order to share device with others.

3.8. Vibration and sound

On **【Profile】** page, tap on **【Settings】** button at upper right corner. You could then turn/off vibration or sound, as shown in the screenshot below.

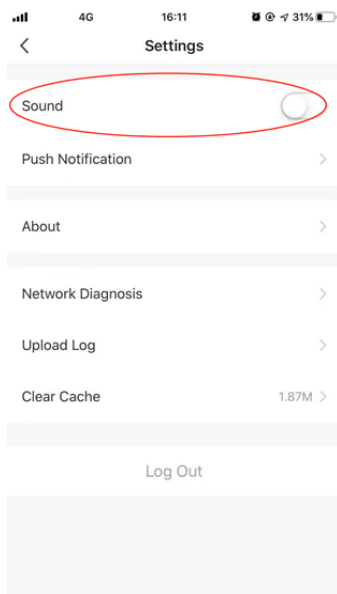

4. Profile

4.1. Logout

On **【Profile】** page, tap on the personal profile menu, you could then logout the current account.

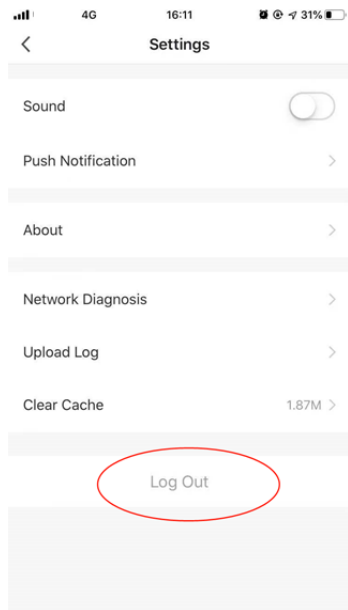

4.2. Modify profile information

On **【profile】** page, tap on the personal profile menu to modify the profile picture, name and other account information.

4.3. FAQ&Feedback

On **【profile】** page, tap on **【Faq&qFeedback】** menu to submit your feedback.

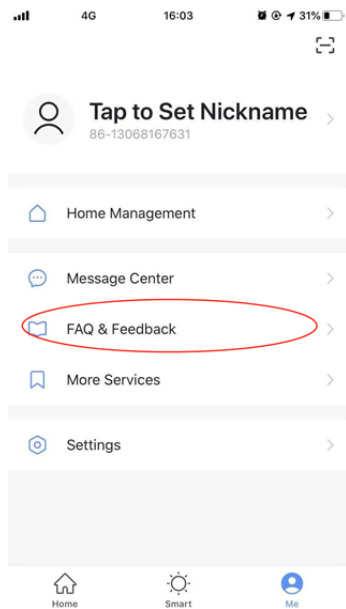

5.WIFI Attentions

5.1 Important notifications

To prevent unnecessary harm, please keep in mind of the following notifications
Please don't use Wi-Fi where the wireless device is not allowed, such as airport, medical places and etc.

Please don't turn on your smartphone in dangerous places, such as gas station, fuel or chemicals manufactures, and etc.

Please don't use mismatched devices.

Please find a qualified repair man to fix the Wi-Fi.

Please refer to the user manual for the detailed connection methods, please don't randomly use mismatched devices.

5.2 Notifications:

5.2.1 The App control quality is affected by your smartphone, Wi-Fi network, distance with router, and internet status. Sometime it is not very smooth. It has nothing to do with air conditioner itself;

5.2.2 If you find it failed to control with your smartphone, please check your internet status at first, then check whether it is successfully connected with air conditioner; If these circumstances are alright, please delete the device first on your App and start the procedures all over again from the step 3.2.

5.2.3 If you still cannot solve the issues with the methods above, please control the Air conditioner with your normal remoter and then request for after-sale service.

BHI Air Conditioner Limited Warranty Statement

The following limited warranty shall apply to only the Original Purchaser, at Original Installation Site, of the BHI products used without interruption by the Original Purchaser.

BHI AIR CONDITIONER LIMITED WARRANTY

Subject to the terms and conditions set forth below, Best Houseware Inc. (Referring to 'We' and 'BHI') warrants the products purchased from BHI or from a BHI authorized reseller/retailer to be free from defects in materials or workmanship under normal consumer use during the respective Warranty Period set forth below. The Limited Warranty begins on the date of original installation (the date stated on the registration form. If products are not registered, the warranty period begins from the delivery time.)

In the event that the product is found to be defective in materials or workmanship during the applicable warranty period, we will repair or replace, at its option, the defective part. We will provide the following benefits, subject to the conditions stated below:

Parts and Accessories- For a period of **ONE (1) YEAR** beginning on the date of this limited warranty applied, we will supply, at its option, either new, like kind or rebuilt replacement parts. Items are not otherwise covered or excluded under this warranty.

Compressor- For a period of **FIVE (5) YEARS** beginning on the date of this limited warranty applied, we will supply, at its option, either new, like kind or rebuilt replacement compressor(s).

PROPER INSTALLATION:

This Limited Warranty applies only to Air Conditioners that are installed in accordance with all applicable building codes and permits, BHI's installation and operation instructions and good trade practices. Installation by contractors who are licensed for HVAC is strongly recommended and registration of product is only available for products installed by HVAC licensed contractor.

REGISTRATION:

Registration of products within 30 days of purchasing provides exact starting date of this limited warranty and streamlined warranty service. Registration form can be downloaded from www.bhiair.com. Please fill it out and email to registration@bhiair.com.

BEST HOUSEWARE INC. WILL PROVIDE WARRANTY SERVICE THROUGH ONE OR MORE OF THE FOLLOWING OPTIONS:

- (i) Carry-in service. You may bring your product to Best Houseware Inc. warehouse or authorized retailers offering carry-in warranty service.
- (ii) Mail-in service. If we determine that your registered product is eligible for mail-in service, company will send you prepaid return label(s) for defective part(s), and send you back the replaced or repaired parts. We will pay for shipping to and from your location if instructions regarding the method of packaging and shipping the product are followed. **THIS SERVICE IS ONLY AVAILABLE TO REGISTERED PRODUCTS.**
- (iii) Drop-in Service. We provide the replacement of defective part(s) for the eligible original purchaser free of charge. Return of the defective parts may be requested for investigation and improvement for the quality of Company's product. Purchaser is solely responsible for the shipping and labor fee.

Any replacement parts will be new or refurbished and the serviced unit will be warranted for the remainder of the original Warranty Period, or thirty (30) days from the date of shipment of the Product back to you, whichever is longer.

EXCLUSION:

- Damage and/or repairs required as a consequence of faulty installation or application;
- Products sold and/or installed outside the lower continental United States (excluded Alaska, Hawaii, or Puerto Rico), and products designed for markets other than the United States;
- Cosmetic blemishes or imperfections that do not affect functionality of the product;

- Product is used for commercial purposes (including rental or lease);
- Product is not sold by Best Houseware Inc. or its authorized retailers;
- Product that has a serial number or any part(s) thereof altered, defaced or removed in any way;
- Labor or other costs incurred for diagnosing, repairing, removing, installing, shipping, servicing or handling of either defective parts, or replacement parts, or new units;
- Damage and/or failure caused by power surge, interruptions of electrical power, faulty power supply, improper wiring or installation or fluctuations in electrical power;
- Damage as a result of freight transportation;
- Any cost to replace, refill or dispose of refrigerant, including the cost of refrigerant;
- Consumable components, such as air filters, are not covered under parts warranty;
- Product installation or set up, or removal of product from the location where it was originally installed;
- Parts not supplied or designated by Best Houseware Inc., or damages resulting from their use;
- Damage and/or failure caused by fire, water, wind, floods, impact damage from projectiles, earthquake, theft, riot, vandalism, forced majeure, acts of war, or any and all acts of God.

Best Houseware Inc. reserves the right to refuse and return, freight collect, Products (i) that are not covered by BHI Air Conditioner Limited Warranty; or (ii) for which there is no trouble found. Product delivered to BHI or BHI's Authorized Service Provider with an expired RMA may be refused and returned, without prior notice, to the Customer freight collect.

Under no circumstances shall Best Houseware Inc. be liable for any indirect, incidental, special, punitive or consequential damages or other economic loss, whether based on breach of warranty, breach of contract, tort or otherwise, even if Best Houseware Inc. has been advised of the possibility of such damage. In no event shall Best Houseware Inc. liability exceed the purchase price of the product.

NO OTHER WARRANTIES:

The expressed warranty stated above is exclusive and in lieu of all other expressed or implied warranties and conditions (if any) including any created by any other statements, documentation, or packaging. No other warranties or conditions are made with respect to the product or warranty services by any person, including but not limited to BHI and its suppliers.

MODIFICATION:

No term or condition of this Limited Warranty may be amended or modified except by an instrument in writing executed by the authority of BHI. BHI holds the right to amend the terms and conditions of this Limited Warranty from time to time without notice.

SEVERABILITY:

Some states do not allow limitations on how long an implied warranty lasts, or the exclusion or limitation of incidental or consequential damages, so the above exclusions or limitations may not apply. Residents of California are not required to register the product in order to obtain all of the rights and remedies applicable to this Limited Warranty.

If a term or condition of this Limited Warranty is held invalid, void or unenforceable, such holding shall not affect any other terms or condition of this Limited Warranty.

OBTAINING WARRANTY SERVICE

To receive instructions for obtaining repair or replacement warranty services as well as general troubleshooting, you may call 909-979-9892 or email us at support@bhiair.com to begin the warranty process. Our office hours are Monday – Friday, 9AM to 5PM Pacific Standard Time. BHI will attempt to resolve technical issues over email or via phone. If a resolution is not possible, we shall issue a Return Merchandise Authorization (RMA) number for a Return. RMA numbers are valid for fifteen (15) days from the date of issuance and void thereafter.