

Tamper resistant self-test GFCI receptacles

Project Name:	Prepared By:
Project Number:	Date:
Catalog Number:	Type:

Description

2-Pole, 3-Wire Grounding
 15A, 125V/AC; 20A, 125V/AC
 NEMA 5-15, 5-20

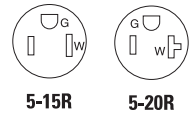

Design features

- Performs periodic self-tests to ensure integrity of GFCI protection. If no ground-fault protection is detected, the device will trip, will not reset, and the status indicator light will glow amber
- Meets and exceeds 10 kA short circuit testing and underwriters laboratories (UL) 2006 UL943 safety standards
- Large visual trip indicator light gives quick notification of a tripped or "end of life" condition
- Automatic grounding system eliminates need for bonding jumper in grounded metal enclosure, provides redundant measure of ground continuity where jumper is used
- Ground termination with back wire clamp provides secure wiring and reduces installation time
- Tamper resistant shutters resist the insertion of foreign objects
- Line side terminals are backed out and staked for fast installation
- Horizontal test/reset button alignment provides larger unobstructed area
- Test and reset buttons are color matched to provide superior aesthetics
- Tapered back wire openings handle multiple wire sizes and types for applications up to #10 AWG solid or stranded wire
- When downstream receptacles are wired from load side, a 20 amp feed-through rating offers full protection
- Line-load miswiring protection: ShockSentry GFCI's will not provide power downstream when wired incorrectly
- Tri-combo head terminal and mounting screws

Table 1. Tamper Resistant Self-Test GFCI Receptacles, Back & Side Wire

Catalog No.	Description	Amps	Volts	Color Suffix
□ TRSGF15__	NEMA 5-15R Duplex self-test GFCI, back & side wire	15	125	A, B, BK, GY, LA, V, W
□ TRSGF20__	NEMA 5-20R Duplex self-test GFCI, back & side wire	20	125	A, B, BK, GY, LA, RD, V, W

Project Name:	Prepared By:
Project Number:	Date:
Catalog Number:	Type:

Applications

GFCI receptacles are designed with the safety of the user in mind. In commercial and industrial areas like public bathrooms, breakrooms and food service areas, the NEC[®] requires GFCI receptacles. Arrow Hart Self-Test GFCI receptacles are UL Listed and fully compliant with all of the latest UL943 Class A GFCI and UL498 requirements. The Self-Test GFCIs conduct an automatic test periodically to ensure GFCI protection. The device will trip and will not reset if GFCI protection is not available. Additionally, GFCIs incorporate a safety lock-out function to protect against mis-wired line-load connections and GFCI circuitry damage.

Table 2. Specifications



Catalog No.	TRSGF
Device Type	Specification grade tamper resistant duplex self-test GFCI, 15A & 20A
Wiring Type	Back & side wire
Testing & Code Compliance	<ul style="list-style-type: none"> cULus Listed to UL498 and UL943, file no. E60120 Meets all UL943 (GFCI), UL498 (Receptacles), UL498 and applicable CSA requirements NOM certified
Environmental Specifications	Flammability: Meets UL 94 requirements; V2 rated Temperature Rating: -35°C to 66°C (-31°F to 150.8°F).
Electrical Specifications	Dielectric Voltage: Withstands 2000V per UL498 Current Interrupting: Yes, at full-rated current Temperature Rise: Max. 30°C (86°F) after 100 cycles of overload @ 150% of rated current (DC) Trip time: 0.025 seconds (Class A) Frequency: 60 Hz; voltage: 125V; amperage: 15A/20A 20A feed through Short circuit testing: Meets and exceeds 10 kA Maximum interrupting capacity: 20 amps
Mechanical Specifications	Terminal Accommodation: #14 - 10 AWG Voltage Ratings: Permanently marked on device

Table 3. Materials

Catalog No.	TRSGF
Top Housing	Nylon
Bottom Housing	PVC
Strap	0.040" thick steel, zinc plated
Line Contacts	0.030" thick 3-leaf brass
Terminal Screws	#8-32 steel, brass plated, hot neutral screw nickel plated
Ground Screw	#8-32 steel, zinc plated (green)
Terminal Clamps	Brass-plated steel;

Table 4. Color Ordering Information

For ordering devices, include Cat. No. followed by the color code: A (Almond), B (Brown), BK (Black), GY (Gray), LA (Lt. Almond), RD (Red), V (Ivory), W (White)

A	B	BK	GY	LA	RD	V	W
Almond	Brown	Black	Gray	Lt. Almond	Red	Ivory	White

Project Name:	Prepared By:
Project Number:	Date:
Catalog Number:	Type:

Wiring Diagrams

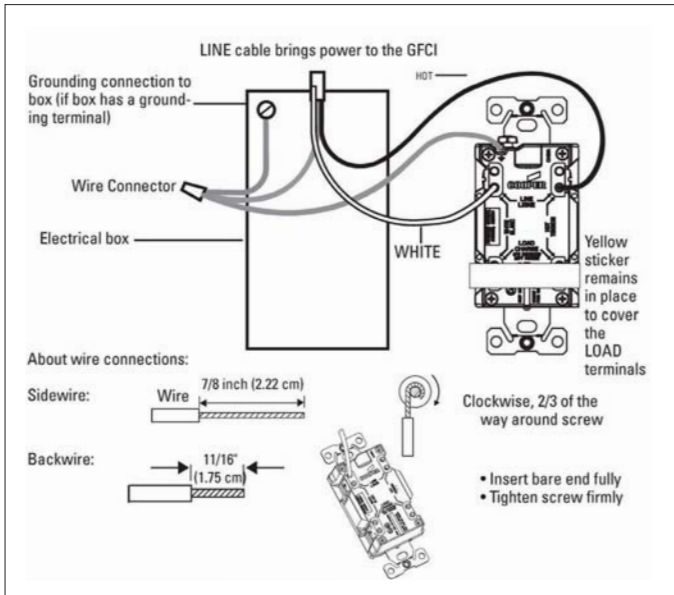

Figure 1. One cable (2 or 3 wires) entering the box

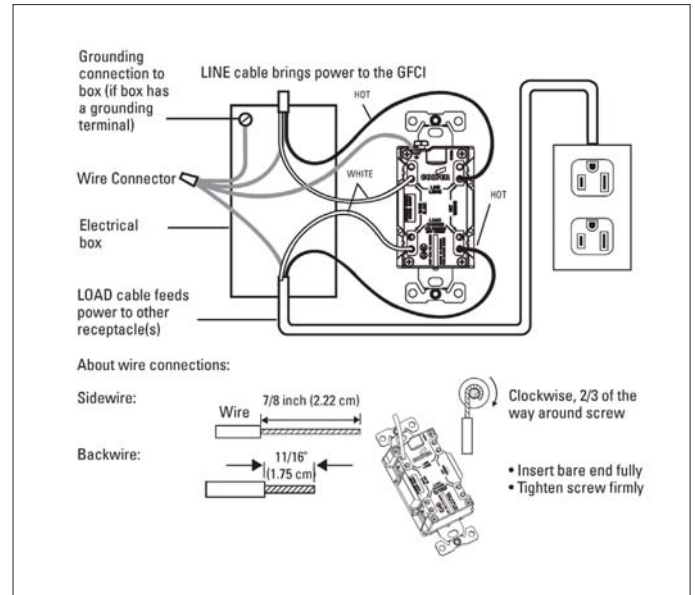

Figure 2. Two cables (4 or 6 wires) entering the box

Product Dimensions

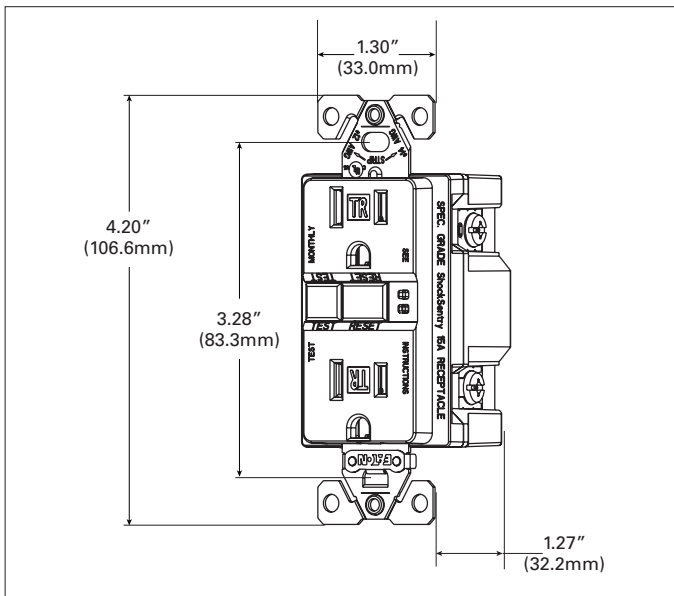

Figure 3. TRSGF15 Line art with dimensions

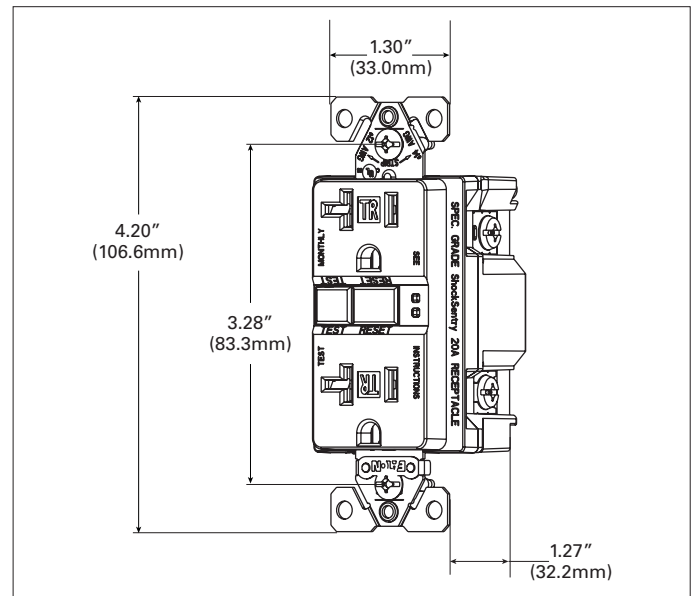





Figure 4. TRSGF20 Line art with dimensions

Technical Data

Effective November 2014

Project Name:	Prepared By:
Project Number:	Date:
Catalog Number:	Type:

Certifications & Compliances

Catalog No.				
TRSGFH15	•	•	•	•
TRSGFH20	•	•	•	•

KEY:  cULus  NOM  Arrowlink  Build-To-Spec

 Build-To-Spec Customizable Devices

Electrical Sector
203 Cooper Circle
Peachtree City, GA 30269
United States
Eaton.com
Cooperwiringdevices.com

Electrical Sector
Canada Operations
5925 McLaughlin Road
Mississauga, Ontario, L5R 1B8
Canada
EatonCanada.ca
Cooperwiringdevices.com

Electrical Sector
Mexico Operations
Carr. Tlalnepantla -
Cuautitlan Km 17.8 s/n
Col. Villa Jardin esq.
Cerrada 8 de Mayo
Cuautitlan, Mexico CP 54800
Mexico
Eaton.mx
Cooperwiringdevices.com

Eaton
1000 Eaton Boulevard
Cleveland, OH 44122
United States
Eaton.com

© 2014 Eaton
All Rights Reserved
Printed in USA
Publication No. E125-0257-14
November 2014

Eaton is a registered trademark.
All other trademarks are property
of their respective owners.