

KOBALT™

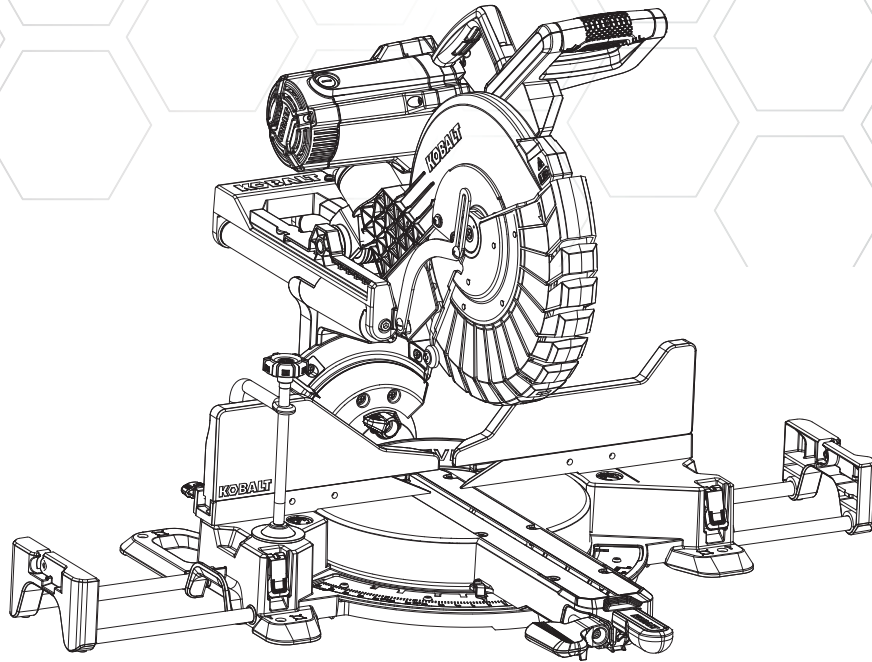

ITEM #5034337

12-IN COMPACT SLIDING DUAL-BEVEL MITER SAW

MODEL #SM3018LW

Español p. 45

KOBALT and logo design are trademarks or registered trademarks of LF, LLC. All rights reserved.

ATTACH YOUR RECEIPT HERE

Serial Number _____ MFG Date _____ Purchase Date _____



Questions, problems, missing parts? Before returning to your retailer, call our customer service department at 888-3KOBALT (888-356-2258), 8 a.m. - 8 p.m., EST, Monday - Sunday. You could also contact us at partsplus@lowes.com.

AS22374

TABLE OF CONTENTS

Product Specifications.....	2
Package Contents.....	3
General Power Tool Safety Warnings.....	6
Electrical Safety Information.....	11
Preparation.....	13
Assembly Instructions.....	14
Adjustment Instructions.....	16
Operating Instructions.....	24
Crown Molding Chart.....	37
Care and Maintenance.....	38
Troubleshooting.....	40
Replacement Parts List.....	41
Warranty.....	44

PRODUCT SPECIFICATIONS

MOTOR		CUTTING CAPACITY	
Power Source	15A, 120V a.c., 60 Hz	Crosscut	Forward fence position: 3-1/2 in. x 14 in. Fence back position: 2 in. x 16 in.
Arbor Shaft Size	5/8 in. with 1 in. blade insert sleeve	Miter 45° Left & Left	Forward fence position: 3-1/2 in. x 9-7/8 in. Fence back position: 2 in. x 11-1/2 in.
Speed (No load)	4200 RPM	Bevel 45° Left	2 in. x 14 in.
Electric Brake	Yes	Bevel 45° Right	1-1/4 in. x 14 in.
Double Insulated	Yes	45° Miter & 45° Bevel (left)	2 in. x 9-7/8 in.
BLADE		45° Miter & 45° Bevel (right)	1-1/4 in. x 9-7/8 in.
Diameter	12 in.	Crown Molding Nested	7-5/32 in.
Arbor	1 in.	Base Molding Against Fence	5-1/32 in.
Tooth Thickness	0.1 in.	Miter Range	0°-55° left, 0°-60° right
		Bevel Range	0°-48° left & right
MITER/BEVEL POSITIVE STOP ANGLES			
Miter Detent Stops	0°, 15°, 22.5°, 31.6°, 45°, 55° left 0°, 15°, 22.5°, 31.6°, 45°, 60° right		
Bevel Positive Stops	0°, 45° left & right		

PACKAGE CONTENTS

UNPACKING YOUR MITER SAW

⚠ WARNING

To avoid injury from unexpected starting or electrical shock, do not plug the power cord into a source of power during unpacking and assembly. The cord must remain unplugged whenever you are adjusting/assembling the saw.

1. Remove the miter saw from the carton.
IMPORTANT: Do not lift miter saw by the trigger switch handle. It may cause misalignment. Lift the saw by the hand holds for transportation.
2. Place the saw on a secure, stationary work surface.
3. Separate all parts from the packing material. Check each one with the illustration below to make certain all items are accounted for before discarding any packing material.

⚠ WARNING

If any part is missing or damaged, do not attempt to assemble the miter saw or plug in the power cord until the missing or damaged part is correctly replaced. To avoid electric shock, use only identical replacement parts when servicing double-insulated tools.

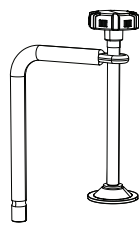
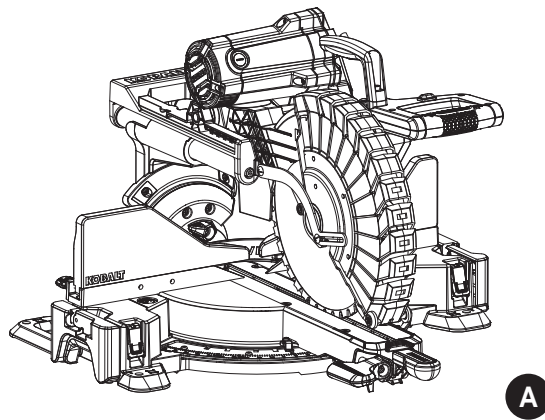

B

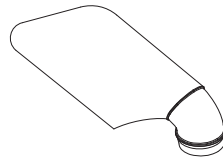

C

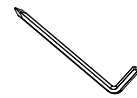

D

PART	DESCRIPTION	QUANTITY
A	Miter saw	1
B	Hold-down clamp	1
C	Dust bag	1
D	Blade wrench	1

KNOW YOUR MITER SAW

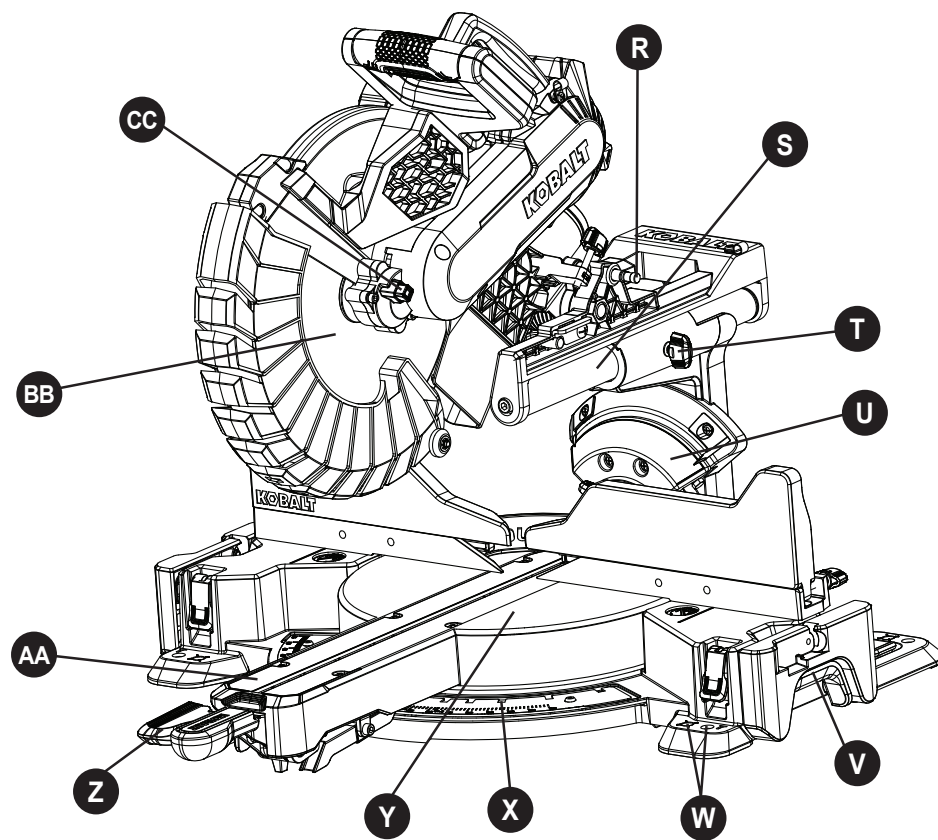
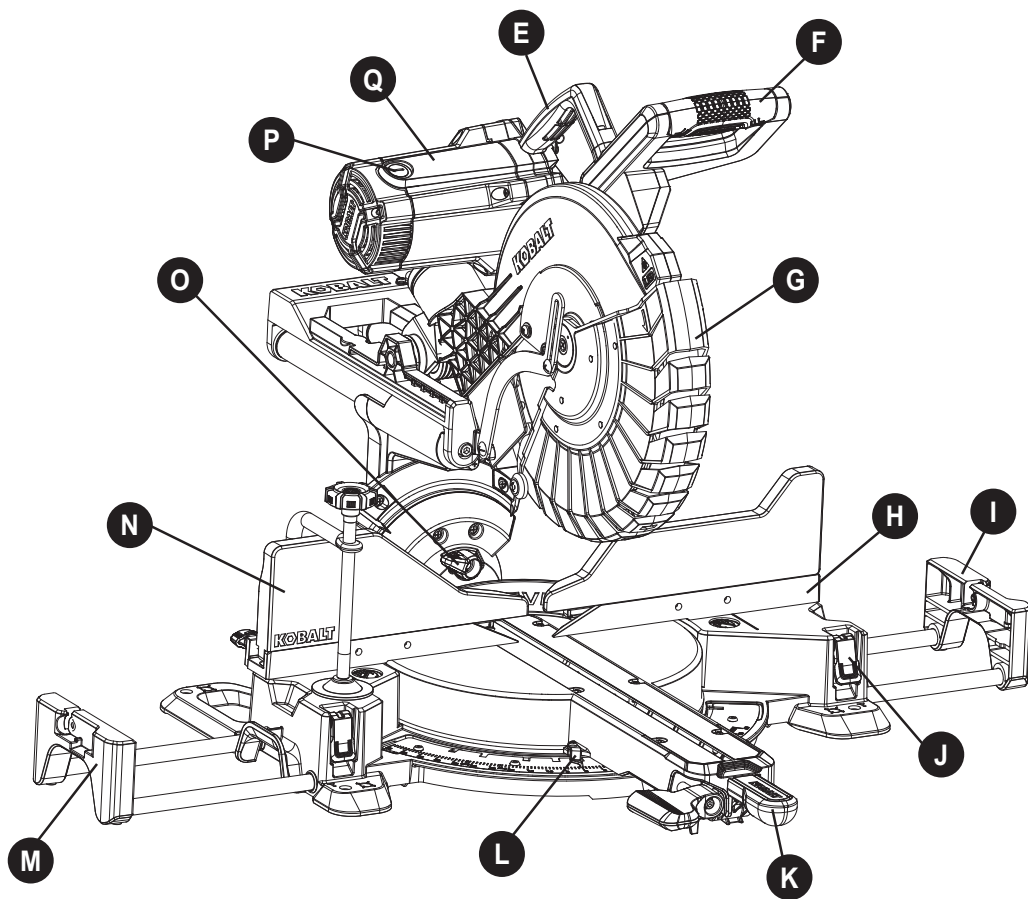

PART	DESCRIPTION	QUANTITY
E	Carrying handle	1
F	Switch handle	1
G	Lower blade guard	1
H	Fence	1
I	Right extension wing	1
J	Extension locking levers	2
K	Miter lock handle	1
L	Miter angle pointer	1
M	Left extension wing	1
N	Sliding fences	2
O	Right bevel detent pin	1
P	Carbon brushes	2
Q	Motor	1
R	Hold-down latch	1
S	Sliding carriages	2
T	Slide carriage lock knob	1
U	Bevel scale	1
V	Hand-hold for transportation	2
W	Mounting holes	8
X	Positive miter stops	11
Y	Miter table	1
Z	Bevel lock handle	1
AA	Table inserts	set of 2
BB	Blade	1
CC	Arbor lock button	1

GENERAL POWER TOOL SAFETY WARNINGS

WARNING

Read all safety warnings, instructions, illustrations and specifications provided with this power tool. Failure to follow all instructions listed below may result in electric shock, fire and/or serious injury.

Save all warnings and instructions for future reference.

The term "power tool" in the warnings refers to your mains-operated (corded) power tool or battery-operated (cordless) power tool.

Work area safety

- **Keep work area clean and well lit.** Cluttered or dark areas invite accidents.
- **Do not operate power tools in explosive atmospheres, such as in the presence of flammable liquids, gases or dust.** Power tools create sparks which may ignite the dust or fumes.
- **Keep children and bystanders away while operating a power tool.** Distractions can cause you to lose control.

Electrical safety

- **Power tool plugs must match the outlet. Never modify the plug in any way. Do not use any adapter plugs with earthed (grounded) power tools.** Unmodified plugs and matching outlets will reduce risk of electric shock.
- **Avoid body contact with earthed or grounded surfaces, such as pipes, radiators, ranges and refrigerators.** There is an increased risk of electric shock if your body is earthed or grounded.
- **Do not expose power tools to rain or wet conditions.** Water entering a power tool will increase the risk of electric shock.
- **Do not abuse the cord. Never use the cord for carrying, pulling or unplugging the power tool. Keep cord away from heat, oil, sharp edges or moving parts.** Damaged or entangled cords increase the risk of electric shock.
- **When operating a power tool outdoors, use an extension cord suitable for outdoor use.** Use of a cord suitable for outdoor use reduces the risk of electric shock.
- **If operating a power tool in a damp location is unavoidable, use a residual current device (RCD) protected supply.** Use of an RCD reduces the risk of electric shock.

Personal safety

- **Stay alert, watch what you are doing and use common sense when operating a power tool. Do not use a power tool while you are tired or under the influence of drugs, alcohol or medication.** A moment of inattention while operating power tools may result in serious personal injury.

- **Use personal protective equipment. Always wear eye protection.** Protective equipment such as dust mask, non-skid safety shoes, hard hat, or hearing protection used for appropriate conditions will reduce personal injuries.
- **Prevent unintentional starting. Ensure the switch is in the off-position before connecting to power source and/or battery pack, picking up or carrying the tool.** Carrying power tools with your finger on the switch or energizing power tools that have the switch on invites accidents.
- **Remove any adjusting key or wrench before turning the power tool on.** A wrench or a key left attached to a rotating part of the power tool may result in personal injury.
- **Do not overreach. Keep proper footing and balance at all times.** This enables better control of the power tool in unexpected situations.
- **Dress properly. Do not wear loose clothing or jewelry. Keep your hair, clothing and gloves away from moving parts.** Loose clothes, jewelry or long hair can be caught in moving parts.
- **If devices are provided for the connection of dust extraction and collection facilities, ensure these are connected and properly used.** Use of dust collection can reduce dust-related hazards.
- **Do not let familiarity gained from frequent use of tools allow you to become complacent and ignore tool safety principles.** A careless action can cause severe injury within a fraction of a second.

Power tool use and care

- **Do not force the power tool. Use the correct power tool for your application.** The correct power tool will do the job better and safer at the rate for which it was designed.
- **Do not use the power tool if the switch does not turn it on and off.** Any power tool that cannot be controlled with the switch is dangerous and must be repaired.
- **Disconnect the plug from the power source and/or remove the battery pack, if detachable, from the power tool before making any adjustments, changing accessories, or storing power tools.** Such preventive safety measures reduce the risk of starting the power tool accidentally.
- **Store idle power tools out of the reach of children and do not allow persons unfamiliar with the power tool or these instructions to operate the power tool.** Power tools are dangerous in the hands of untrained users.
- **Maintain power tools and accessories. Check for misalignment or binding of moving parts, breakage of parts and any other condition that may affect the power tool's operation. If damaged, have the power tool repaired before use.** Many accidents are caused by poorly maintained power tools.
- **Keep cutting tools sharp and clean.** Properly maintained cutting tools with sharp cutting edges are less likely to bind and are easier to control.

- **Use the power tool, accessories and tool bits etc. in accordance with these instructions, taking into account the working conditions and the work to be performed.** Use of the power tool for operations different from those intended could result in a hazardous situation.
- **Keep handles and grasping surfaces dry, clean and free from oil and grease.** Slippery handles and grasping surfaces do not allow for safe handling and control of the tool in unexpected situations.

Service

- **Have your power tool serviced by a qualified repair person using only identical replacement parts.** This will ensure that the safety of the power tool is maintained.

SAFETY INSTRUCTIONS FOR MITER SAWS

- **Miter saws are intended to cut wood or wood-like products, they cannot be used with abrasive cut-off wheels for cutting ferrous material such as bars, rods, studs, etc.** Abrasive dust causes moving parts such as the lower guard to jam. Sparks from abrasive cutting will burn the lower guard, the kerf insert and other plastic parts.
- **Use clamps to support the workpiece whenever possible. If supporting the workpiece by hand, you must always keep your hand at least 8-3/4 in. (222 mm) from either side of the saw blade. Do not use this saw to cut pieces that are too small to be securely clamped or held by hand.** If your hand is placed too close to the saw blade, there is an increased risk of injury from blade contact.
- **The workpiece must be stationary and clamped or held against both the fence and the table. Do not feed the workpiece into the blade or cut "freehand" in any way.** Unrestrained or moving workpieces could be thrown at high speeds, causing injury.
- **Push the saw through the workpiece. Do not pull the saw through the workpiece. To make a cut, raise the saw head and pull it out over the workpiece without cutting, start the motor, press the saw head down and push the saw through the workpiece.** Cutting on the pull stroke is likely to cause the saw blade to climb on top of the workpiece and violently throw the blade assembly towards the operator.
- **Never cross your hand over the intended line of cutting either in front or behind the saw blade.** Supporting the workpiece "cross handed" i.e. holding the workpiece to the right of the saw blade with your left hand or vice versa is very dangerous.
- **Do not reach behind the fence with either hand closer than 8-3/4 in. (222 mm) from either side of the saw blade, to remove wood scraps, or for any other reason while the blade is spinning.** The proximity of the spinning saw blade to your hand may not be obvious and you may be seriously injured.
- **Inspect your workpiece before cutting. If the workpiece is bowed or warped, clamp it with the outside bowed face toward the fence. Always make certain that there is no gap between the workpiece, fence and table along the line of the cut.** Bent or warped workpieces can twist or shift and may cause binding on the spinning saw blade while cutting. There should be no nails or foreign objects in the workpiece.

- **Do not use the saw until the table is clear of all tools, wood scraps, etc., except for the workpiece.** Small debris or loose pieces of wood or other objects that contact the revolving blade can be thrown with high speed.
- **Cut only one workpiece at a time.** Stacked multiple workpieces cannot be adequately clamped or braced and may bind on the blade or shift during cutting.
- **Ensure the miter saw is mounted or placed on a level, firm work surface before use.** A level and firm work surface reduces the risk of the miter saw becoming unstable.
- **Plan your work. Every time you change the bevel or miter angle setting, make sure the adjustable fence is set correctly to support the workpiece and will not interfere with the blade or the guarding system.** Without turning the tool "ON" and with no workpiece on the table, move the saw blade through a complete simulated cut to assure there will be no interference or danger of cutting the fence.
- **Provide adequate support such as table extensions, sawhorses, etc. for a workpiece that is wider or longer than the table-top.** Workpieces longer or wider than the miter saw table can tip if not securely supported. If the cut-off piece or workpiece tips, it can lift the lower guard or be thrown by the spinning blade.
- **Do not use another person as a substitute for a table extension or as additional support.** Unstable support for the workpiece can cause the blade to bind or the workpiece to shift during the cutting operation pulling you and the helper into the spinning blade.
- **The cut-off piece must not be jammed or pressed by any means against the spinning saw blade.** If confined, i.e. using length stops, the cut-off piece could get wedged against the blade and thrown violently.
- **Always use a clamp or a fixture designed to properly support round material such as rods or tubing.** Rods have a tendency to roll while being cut, causing the blade to "bite" and pull the work with your hand into the blade.
- **Let the blade reach full speed before contacting the workpiece.** This will reduce the risk of the workpiece being thrown.
- **If the workpiece or blade becomes jammed, turn the miter saw off. Wait for all moving parts to stop and disconnect the plug from the power source and/or remove the battery pack. Then work to free the jammed material.** Continued sawing with a jammed workpiece could cause loss of control or damage to the miter saw.
- **After finishing the cut, release the switch, hold the saw head down and wait for the blade to stop before removing the cut-off piece.** Reaching with your hand near the coasting blade is dangerous.
- **Hold the handle firmly when making an incomplete cut or when releasing the switch before the saw head is completely in the down position.** The braking action of the saw may cause the saw head to be suddenly pulled downward, causing a risk of injury.
- **Do not use** this saw to cut tree limbs or logs.
- **Never** use blades recommended for operation at less than 4,200 RPM.
- **Do not use** this saw to cut fiber cement board. This saw is not intended to cut fiber cement boards.

 **WARNING**

Additional warnings are listed throughout this manual. Please review all before operating this power tool.

PROPOSITION 65 WARNING

WARNING

Drilling, sawing, sanding or machining wood products can expose you to wood dust, a substance known to the State of California to cause cancer. Avoid inhaling wood dust or use a dust mask or other safeguards for personal protection. For more information go to: www.P65Warnings.ca.gov/wood

Some examples of these chemicals are:

- Lead from lead-based paints,
- Crystalline silica from bricks and cement and other masonry products, and
- Arsenic and chromium from chemically treated lumber.

Your risk from these exposures varies depending on how often you do this type of work. To reduce your exposure to these chemicals: work in a well-ventilated area and work with approved safety equipment, such as those dust masks that are specially designed to filter out microscopic particles.

Handling the power cord on this product may expose you to chemicals known to the state of California to cause cancer and birth defects or other reproductive harm. Wash hands after handling.

For more information go to: www.P65Warnings.ca.gov



READ INSTRUCTION MANUAL: To reduce the risk of injury, user and all bystanders must read instruction manual before using this product.

⚠ ELECTRICAL SAFETY INFORMATION

ELECTRICAL SPECIFICATIONS AND SAFETY

POWER SUPPLY AND MOTOR

⚠ CAUTION

The A/C motor used in this saw is a universal, nonreversible type. See “MOTOR” in the “PRODUCT SPECIFICATIONS” section on page 2.

To avoid electrical hazards, fire hazards or damage to the tool, use proper circuit protection. Your saw is wired at the factory for 120 V operation. Connect to a 120 V, 15 A circuit and use a 20 A time-delay fuse or circuit breaker. If power cord is worn or cut or damaged in any way, have it replaced immediately to avoid shock or fire.

DOUBLE INSULATED (Symbol:)

This power tool is double insulated to provide a double thickness of insulation between you and the tool’s electrical system. All exposed metal parts are isolated from the internal metal motor components with protective insulation.

REPLACEMENT PARTS – When servicing, use only identical replacement parts. Refer to the Replacement Parts List on the page 41.

POLARIZED PLUGS – To reduce the risk of electrical shock, this saw has a polarized plug (one blade is wider than the other). This plug (illustrated at right) will fit in a polarized outlet only one way. If the plug does not fit fully in the outlet, reverse the plug. If it still does not fit, contact a qualified electrician to install the proper outlet. Do not change the plug in any way.

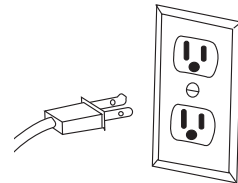

⚠ CAUTION

Double insulation does not take the place of normal safety precautions when operating this tool. To avoid electrocution:

- Use only identical replacement parts when servicing a tool with double insulation. Servicing should be performed by a qualified technician.
- Do not use power tools in wet or damp locations or expose them to rain or snow.

MOTOR SAFETY PROTECTION

⚠ CAUTION

To avoid motor damage, the motor should be blown out or vacuumed frequently to keep sawdust from interfering with motor ventilation.

- **CONNECT** this saw to a 120 V, 15 A circuit with a 20 A time-delay fuse or circuit breaker. Using the wrong size fuse can damage the motor.
- If the motor will not start, release the trigger switch immediately. **UNPLUG THE SAW.** Check the saw blade to make sure it turns freely. If the blade is free, try to start the saw again. If the motor still does not start, refer to **TROUBLESHOOTING**.
- If the tool suddenly stalls while cutting wood, release the trigger switch, unplug the tool and free the blade from the wood. The saw may now be started and the cut finished.

- **FUSES** may “blow” or circuit breakers may trip frequently if:
 - **MOTOR** is overloaded – overloading can occur if you feed too rapidly or make too many starts/stops in a short time.
 - **LINE VOLTAGE** is more than 10% above or below the nameplate voltage rating. For heavy loads, the voltage at motor terminals must equal the voltage specified on the nameplate.
 - **IMPROPER** or dull saw blades are used.

GUIDELINES FOR EXTENSION CORDS

When using an extension cord, be sure to use one heavy enough to carry the current your product will draw. An undersized cord will cause a drop in line voltage, resulting in loss of power and overheating. The table below shows the correct size to use depending on cord length and nameplate ampere rating. If in doubt, use the next heavier gauge. The smaller the gauge number, the heavier the cord.

MINIMUM GAUGE FOR EXTENSION CORDS (AWG)					
(When using 120 volts only)					
Ampere Rating		Total length of Cord			
More Than	Not More Than	25 ft.	50 ft.	100 ft.	150 ft.
0	6	18	16	16	14
6	10	18	16	14	12
10	12	16	16	14	12
12	16	14	12	Not Recommended	

Be sure your extension cord is properly wired and in good condition. Always replace a damaged extension cord or have it repaired by a qualified person before using it. Protect your extension cords from sharp objects, excessive heat and damp or wet areas.

Use a separate electrical circuit for your tools. This circuit must not be less than #12 wire and should be protected with a 20 A time-delay fuse or circuit breaker. Before connecting the tool to the extension cord, make sure the saw switch is in the OFF position. The electric circuit should be rated at the same voltage as is stamped on the motor nameplate. Running at a lower voltage will damage the motor.

⚠ CAUTION

In all cases make certain the receptacle in question is properly grounded. If you are not sure, have a certified electrician check the receptacle.

PREPARATION

Before beginning assembly or operation of the product, make sure all parts are present. Compare parts with package contents list and diagram on page 3. If any part is missing or damaged, do not attempt to assemble, install or operate the product.

Estimated Assembly Time: 10 minutes.

Tools needed to remove or install blade (included): Blade Wrench.

Tools Required for Adjustment (not included): Adjustable Wrench, 5 mm Hex Wrench, 10 mm Hex Wrench, Combination Square, Phillips Screwdriver

ASSEMBLY INSTRUCTIONS

⚠ WARNING

To avoid injury, do not connect this miter saw to a power source until it is completely assembled and adjusted and you have read and understood the operator's manual.

UNLOCKING THE SLIDE CARRIAGE (FIG. 1)

The slide carriage lock knob (T) is located on the right side of the slide carriage. After removing the saw from the carton, loosen the slide carriage lock knob (T). When transporting or storing the miter saw, the slide carriage should always be locked in position.

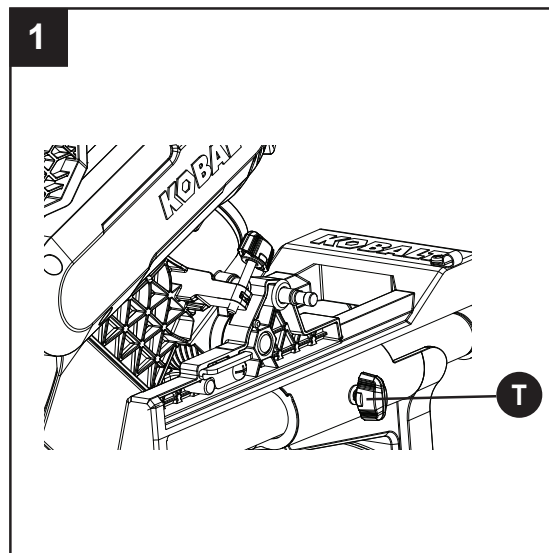

BLADE WRENCH (FIG. 2)

For convenient storage and prevention of loss, there is a holder in the rear of the right side fence for storing the blade wrench (D) when not in use. Place the provided wrench in this location.

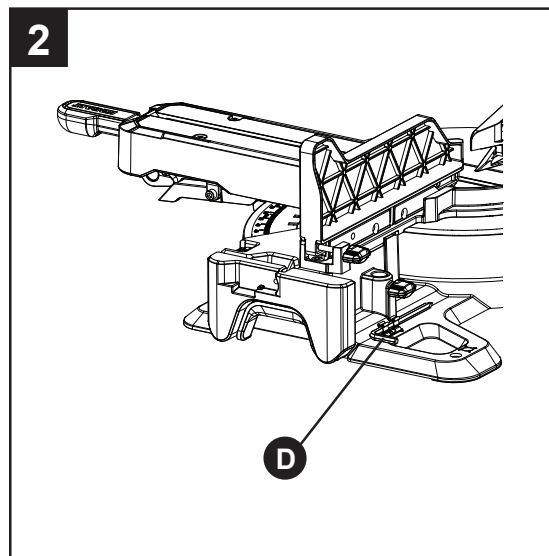

INSTALLING THE DUST BAG (FIG. 3)

- Install the dust bag (C) onto the exhaust port (1) on the miter saw. Fit the connecting tube of dust bag and the exhaust port together. The dust bag assembly should be angled toward the side of the saw (as shown in Fig. 3) for best results. This will also avoid any interference during the saw operation.

NOTE: To empty the dust bag, pull out the dust bag from exhaust port. Open zipper on underside of bag and empty into waste container.

IMPORTANT: Check frequently and empty bag before it gets full.

⚠ WARNING

Do not use this saw to cut and/or sand metals. The hot chips or sparks may ignite sawdust from the bag material.

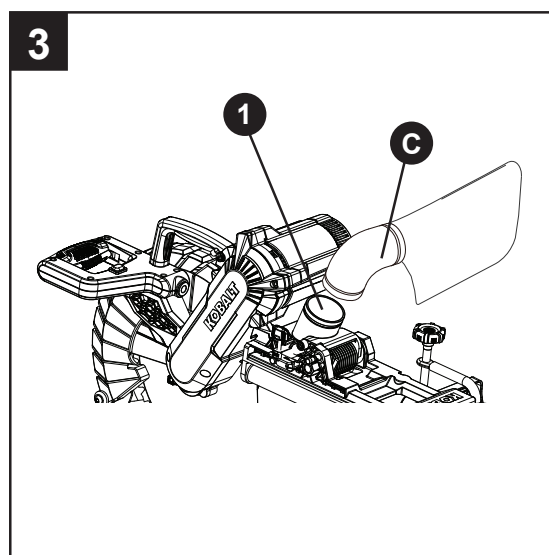

INSTALLING THE HOLD-DOWN CLAMP (FIG. 4)

NOTE: There are two mounting holes for the hold-down clamp. These are located just behind the fence on the left and right side of the base.

- Loosen the lock knob (1) behind the fence.
- Place the hold-down clamp assembly (B) in the desired mounting holes.
- Tighten the lock knob (1).

NOTE: Place the clamp on the opposite side of the base when beveling. Always make dry runs (unpowered) before finish cuts to check the path of the blade. ensure the clamp does not interfere with the action of the saw or guards.

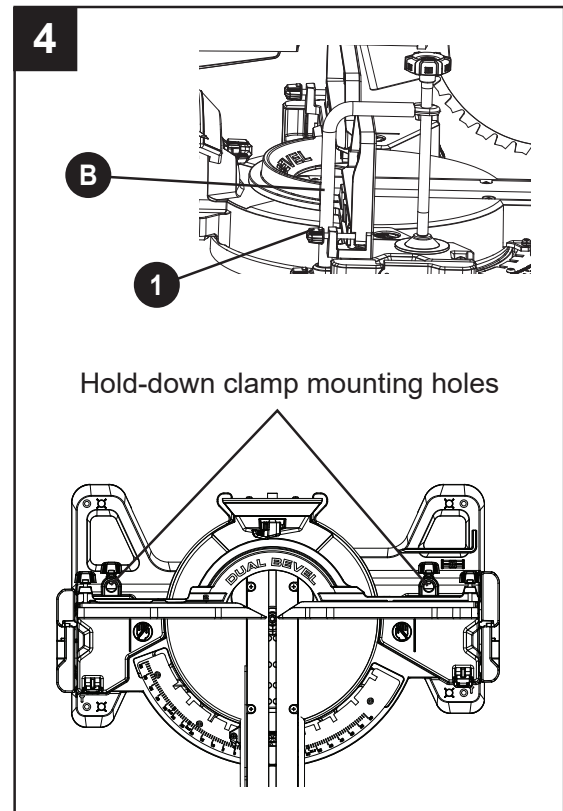

ADJUSTMENT INSTRUCTIONS

REMOVING AND INSTALLING THE TABLE INSERTS (FIG. 5)

NOTE: The miter saw comes with the table inserts already installed. These instructions are for replacing or adjusting the inserts.

⚠ WARNING

To avoid injury:

- Always unplug the saw to avoid accidental starting. Remove all small pieces of material from the table cavity before performing any cuts. The table inserts may be removed for this purpose, but always reattach the table inserts prior to performing a cutting operation.
- Do not start the sliding compound miter saw without checking for interference between the blade and table inserts. Damage could result to the blade, table inserts or turntable if blade strike occurs during the cutting operation.
- To remove, loosen and remove the six screws (1) on the table inserts (AA) with a Phillips screwdriver and remove the inserts.
- To install, reposition the left and right side table inserts on either side of the cut line, replace the six screws and tighten.
- Check for blade clearance by moving the slide carriage through the full motion of the blade in the table slot. If neither side of the inserts hits the saw blade, loosen the three screws for that side and adjust. Tighten the screws and check again for blade clearance.

⚠ WARNING

Never use the saw without the table inserts in place.

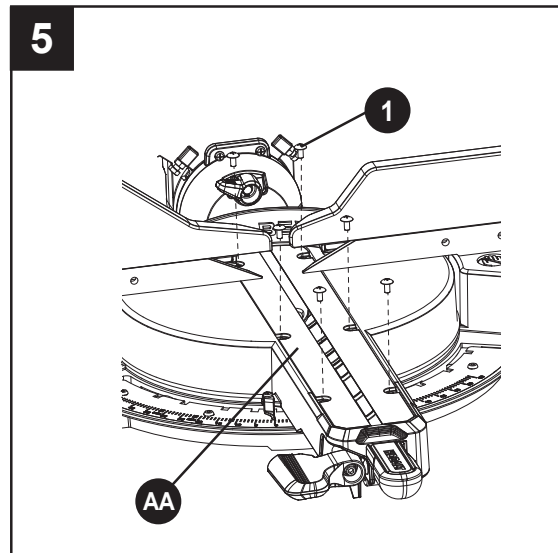

MOUNTING THE MITER SAW (FIG. 6, 7, 8)

⚠ WARNING

To avoid injury from unexpected saw movement:

- Disconnect the power cord from the outlet and lock the cutting head in the lower position using the hold-down latch.
- Lock the slide carriage in place by tightening the slide carriage lock knob.
- To avoid back injury, lift the saw by using the hand holds for transportation. Bend with your knees, not your back.
- Never carry the miter saw by the power cord or by the switch handle. Carrying the tool by the power cord could cause damage to the insulation or the wire connections resulting in electric shock or fire.
- To avoid injury from flying debris, do not allow visitors to stand near the saw during any cutting operations.

Mounting instructions:

- **For stationary use**, place the saw in the desired location, directly on a workbench where there is room for handling and proper support of the workpiece. The base of the saw has eight mounting holes (W - Fig. 6), four $\frac{2}{5}$ in. holes and four $\frac{7}{25}$ in. holes for mounting the saw to the work surface. Bolt the base of the miter saw (1) to the work surface (5), using the recommended fastening method as shown in Fig. 7.

NOTE: Mounting hardware is not included with this tool. Bolts, nuts, washers and screws must be purchased separately.

- **For portable use**, place the saw on a $\frac{3}{4}$ in. thick piece of plywood. Bolt the base of the miter saw securely to the plywood using the holes (W - Fig. 6) on the base. Use C-clamps to clamp this mounting board to a stable work surface at the worksite. (Fig. 8)
- NOTE:** If a miter saw stand is used, please follow all instructions shown in that product's instructions for proper mounting.

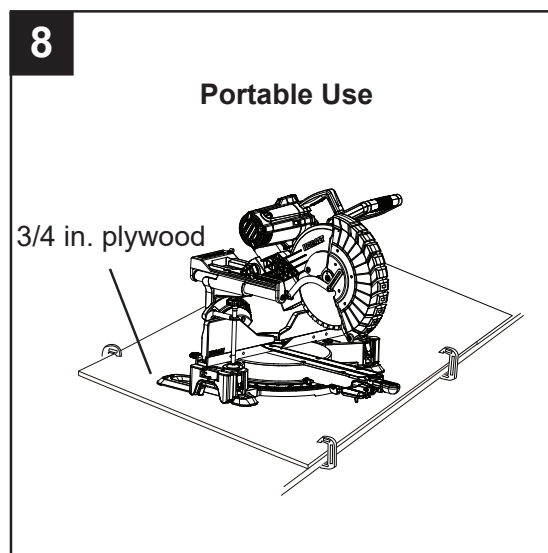
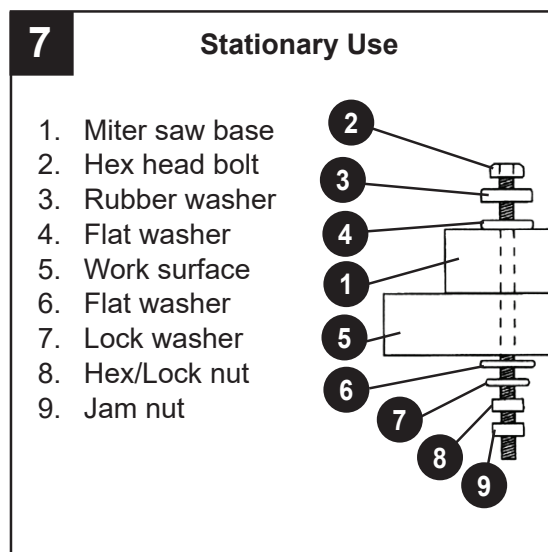
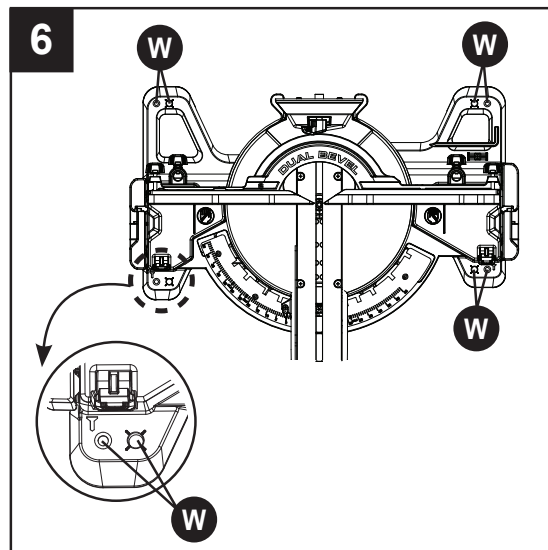

REMOVING AND INSTALLING THE BLADE

⚠ WARNING

- Use only a saw blade diameter in accordance with the markings on the saw.
- Only use 12 in. diameter blade with a 1 in. arbor hole and an operating speed of more than 4,200 RPM. Do not use blades with deep gullets. These can deflect and contact the guard, causing damage to the machine and/or serious injury.
- To avoid injury from an accidental start, make sure the switch is in the OFF position and the plug is not connected to the power source outlet.

REMOVING THE BLADE (FIG. 9, 10, 11, 12, 13)

- Unplug the saw from the outlet.
- Raise the cutting head to its upright position as shown in Fig. 9. Raise the lower blade guard (G) to the up position shown in Fig. 9.
- Loosen the cover plate screw (1) by using the Phillips head end of the provided blade wrench (D). Only loosen it enough to position past the tab (2). (Fig. 9)

NOTE: Do not remove this screw.

- Rotate the lower blade guard (G) back to its down position about half way. The cover plate screw (1-Fig. 9) should stop the guard from moving any further and move the cover plate (3) upward to expose the arbor bolt (4). (Fig. 10)
- Place the blade wrench (D) with hex end over the arbor bolt (4). (Fig. 11)
- Locate the arbor lock button (CC) on the right, below the belt cover. (Fig. 12)
- Press the arbor lock button (CC), holding it in firmly while turning the blade wrench clockwise. The arbor lock will engage after turning the wrench, stopping the rotation of the blade. Continue to hold the arbor lock button (CC) to keep it engaged while turning the wrench clockwise to loosen the arbor bolt.
- Remove the arbor bolt (4), the blade collar (5) and the blade (BB), as shown in Fig. 13. Do not remove the inner blade collar (6).

NOTE: The blade has an insert sleeve (7) to allow the 1 in. arbor hole in the blade to fit the 5/8 in. arbor on the motor. **DO NOT THROW OUT.**

NOTE: Pay attention to the pieces removed, noting their position and direction they face. Wipe the blade collar clean of any sawdust before installing a new blade.

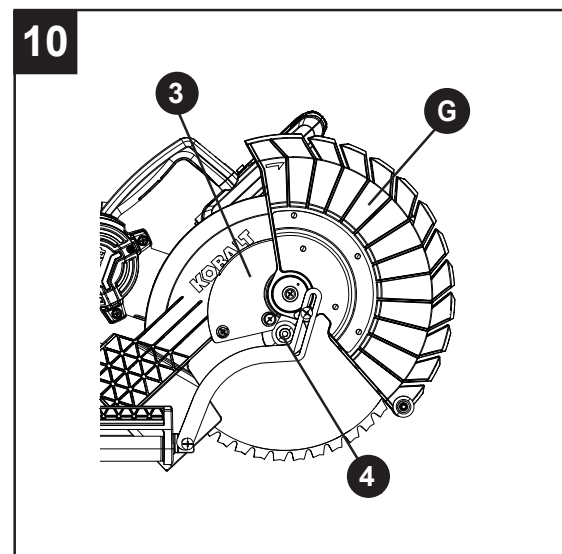
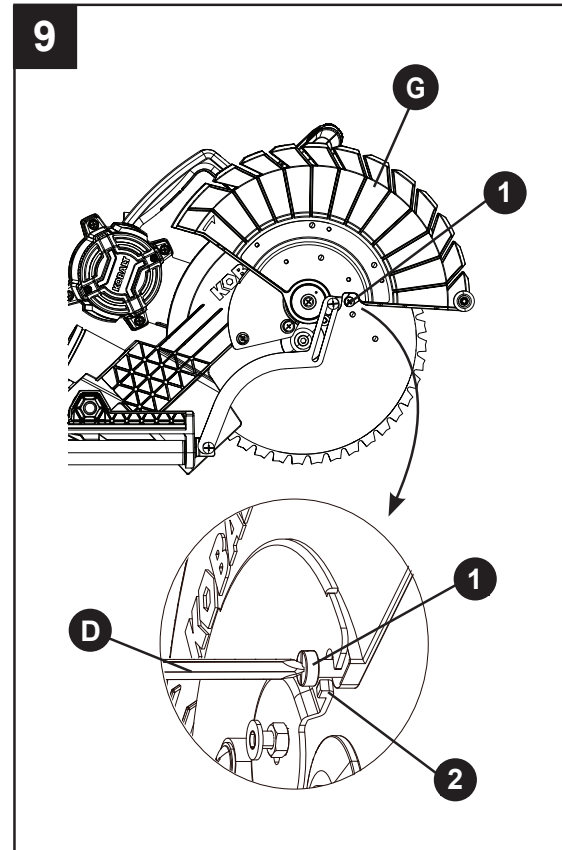

INSTALLING THE BLADE

(FIG. 9, 10, 11, 12, 13)

Unplug the miter saw before changing/installing the blade.

- Install a 12 in. blade with a 1 in. arbor, using the provided blade insert sleeve (7) to match the 5/8 in. motor arbor. Make sure the rotation arrow on the blade matches the clockwise rotation arrow on the upper guard. (Fig. 13)
- Place the outer blade collar (5) against the blade and on the arbor. Thread the arbor bolt (4) onto the arbor in a counterclockwise direction.

IMPORTANT: Make sure the flats of the blade collars are engaged with the flats on the arbor shaft. Also, the flat side of the blade collar must be placed against the blade.

- Place the hex end of blade wrench (D) on the arbor bolt (4). (Fig. 11)
- Press the arbor lock button (CC), holding it in firmly while turning the blade counterclockwise. When arbor lock engages, continue to press it in while turning the blade wrench counterclockwise, tightening the arbor bolt securely. (Fig. 12)
- Rotate the lower blade guard (G) to its up position. The cover plate should move to its original position. Then tighten the cover plate screw (1) with the phillips head end of provided blade wrench. (Fig. 9)
- Lower the blade guard (G) and verify that the operation of the guard does not bind or stick.
- Be sure the arbor lock is released so the blade turns freely before operating the saw.

⚠ WARNING

- To avoid injury, never use the saw without the cover plate securely in place. It keeps the arbor bolt from falling out if it accidentally loosens and helps prevent the spinning blade from coming off the saw.
- Make sure the collars are clean and properly arranged. Lower the blade into the lower table and check for any contact with the metal base or the miter table.
- To avoid injury from an accidental start, make sure the switch is in the OFF position and the plug is not connected to the power source outlet.
- Never cut metals or masonry products with this tool. This miter saw is designed for use on wood and wood-like products only.

⚠ WARNING

Always make dry runs (unpowered) before finish cuts to check the path of the blade and the operation of the guards.

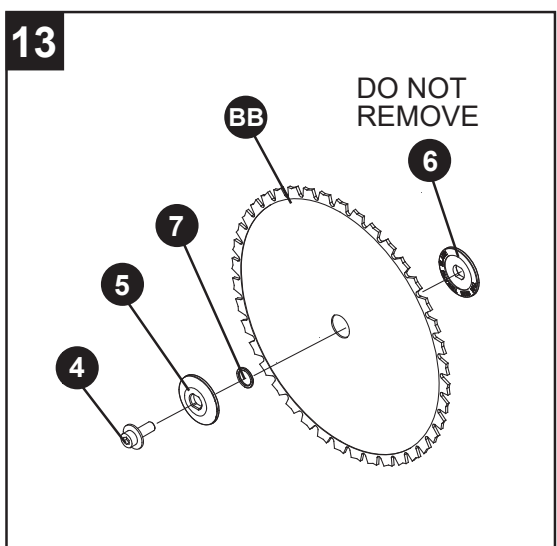
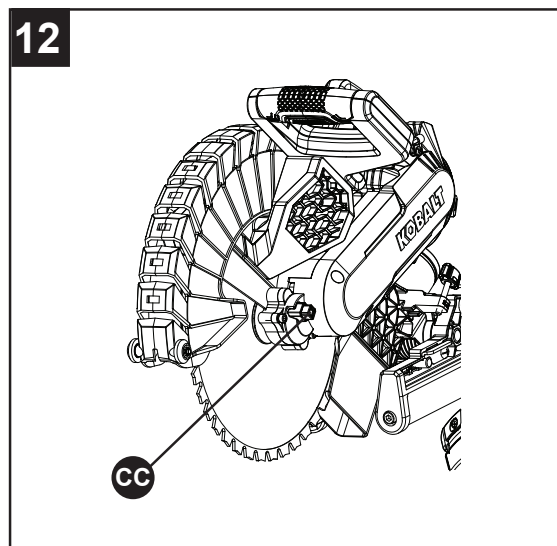
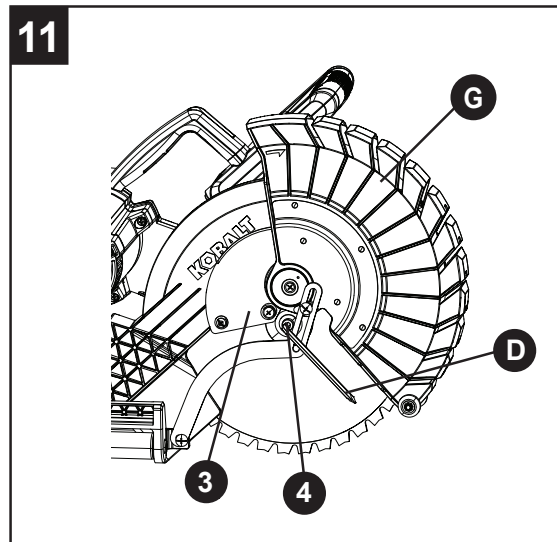

UNLOCKING AND LOCKING THE CUTTING HEAD (FIG. 14)

Unlocking the cutting head:

- To raise the cutter head from its storage/transport position, push down slightly on the switch handle (F).
- Pull out the hold-down latch (R).
- Allow the cutting head to rise to the up position.

Locking the cutting head:

When transporting or storing the miter saw, the cutting head should always be locked in the down position.

- Push the cutting head down to its lowest position.
- Push the hold-down latch (R) into the locking hole.

⚠ CAUTION

To avoid injury and damage to the saw, transport and store the miter saw with the cutting head locked in the down position. Never use the stop latch to hold the cutting head in a down position for cutting operations.

IMPORTANT: To avoid damage, never carry the miter saw by the switch handle, the cutting arm or the miter table handle. ALWAYS use the designated carrying handles.

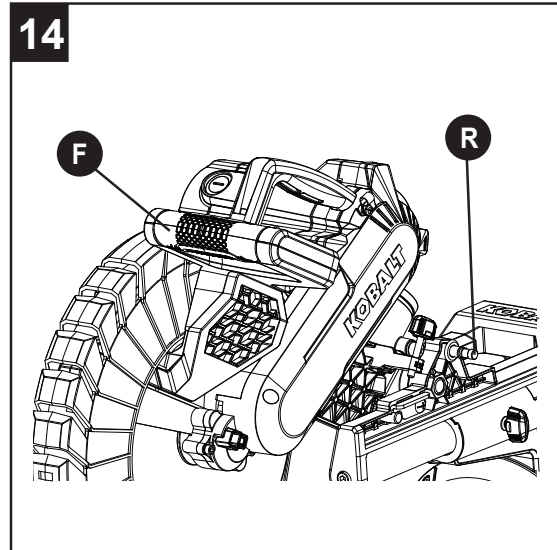

BEVEL STOP ADJUSTMENT (FIG. 15, 16, 17)

⚠ WARNING

To avoid injury from an accidental start, make sure the switch is in the OFF position and the plug is not connected to the power source outlet.

90° (0°) Bevel Adjustment (Fig. 15, 16):

- Loosen bevel lock handle (Z) and tilt the cutting arm completely to the right. Tighten the bevel lock handle (Z).
- Place a combination square (1) on the miter table (Y) with the ruler against the table and the heel of the square against the saw blade.
- If the blade is not 90° square with the miter table loosen the bevel lock handle (Z), tilt the cutting head to the right by pulling out the right bevel detent pin (O-Fig. 16), adjust the bevel angle adjustment bolt (2) in or out with a 10 mm wrench until the blade is square with the table.
- Tilt the cutting arm back to the right at 90° (0°) bevel and recheck for alignment.
- Repeat above steps if further adjustment is needed.
- Tighten bevel lock handle (Z) when alignment is achieved.

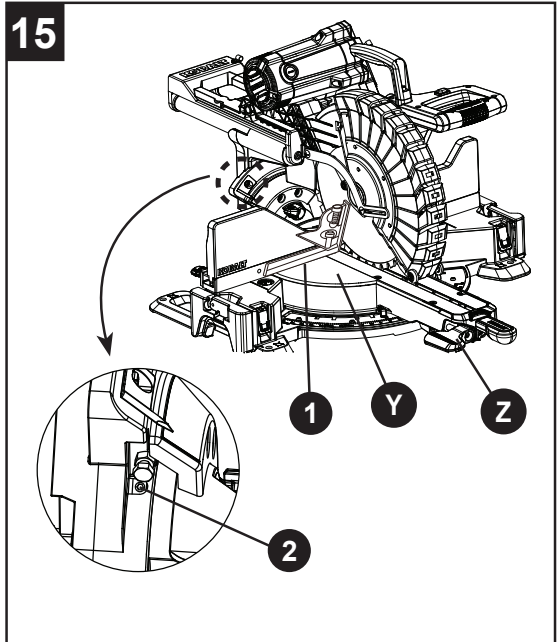

90° Bevel Pointers Adjustment (Fig. 16):

- When the blade is exactly 90° to the table, loosen the bevel pointer screws (1) using a Phillips screwdriver.
- Adjust bevel pointers (2) to the “0” mark on the bevel scale and retighten the screw.

⚠ WARNING

To avoid injury from an accidental start, make sure the switch is in the OFF position and the plug is not connected to the power source outlet.

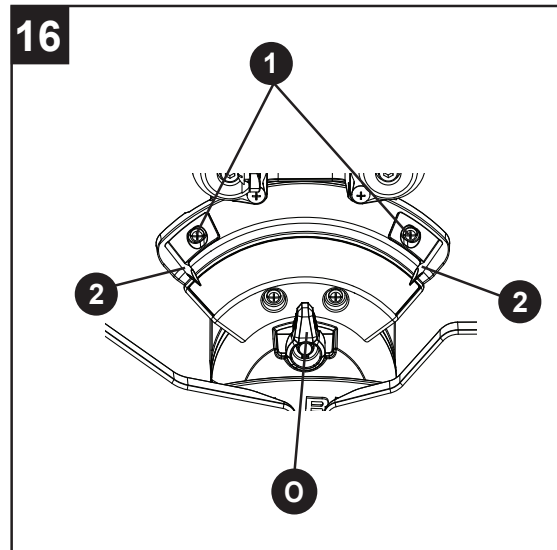

Left/Right 45° Bevel Adjustment (Fig. 17):

- Loosen the bevel lock handle (Z) by lifting up and tilt the cutting head completely to the left.
- Using a combination square, check to see if the blade angle is 45° to the table.
- If the blade is not at 45° to the miter table, tilt the cutting arm to the right, loosen the jamb nut (1) and turn the bevel angle adjustment bolt (2) in or out with a 10 mm wrench.
- Tilt the cutting arm to the left 45° bevel and recheck for alignment.
- Repeat above until the blade is at 45° to the miter table.
- Tighten bevel lock handle (Z) and jamb nut (1) when alignment is achieved.
- Adjust the 45° bevel on the other side following the same steps listed above.

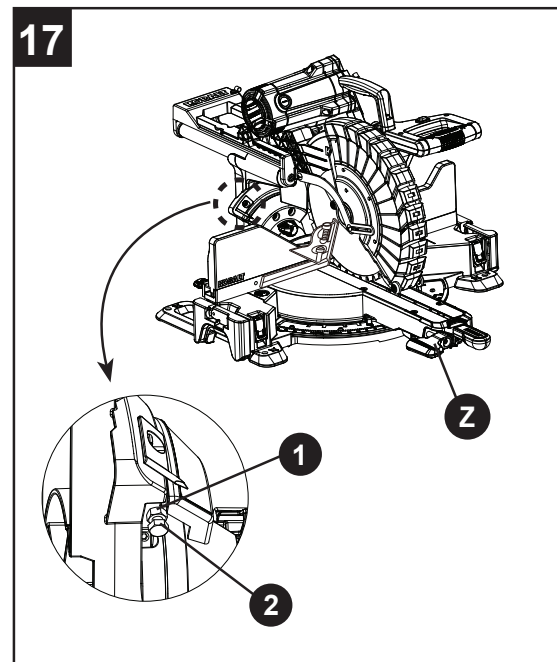

MITER SCALE (FIG. 18)

The sliding compound miter saw scale can be easily read, showing miter angles from 0° to 55° left and 0° to 60° right. The most common angle settings have positive stops at 0°, 15°, 22.5°, 31.6°, 45° left and right, 55° left and 60° right only. These positive stops position the blade at the desired angle quickly and accurately. Follow the instructions below for quickest and most accurate adjustments.

To Adjust Miter Angles:

- Lift up on the miter lock handle (K) to unlock the table.
- Move the table to align the pointer (L) to the desired degree measurement.
- If the desired angle is one of the eleven positive stops, making sure it snaps into position, then secure by pressing down the miter lock handle (K).
- If the miter angle desired is not one of the eleven positive stops, simply lock the miter table into position by pressing down on the miter lock handle (K).

Miter Angle Pointer Adjustment (Fig. 18):

- Move the table to the 0° positive stop.
- Loosen the screw (1) that holds the pointer (L) with a Phillips screwdriver.
- Adjust the pointer (L) to the 0° mark and retighten the screw (1).

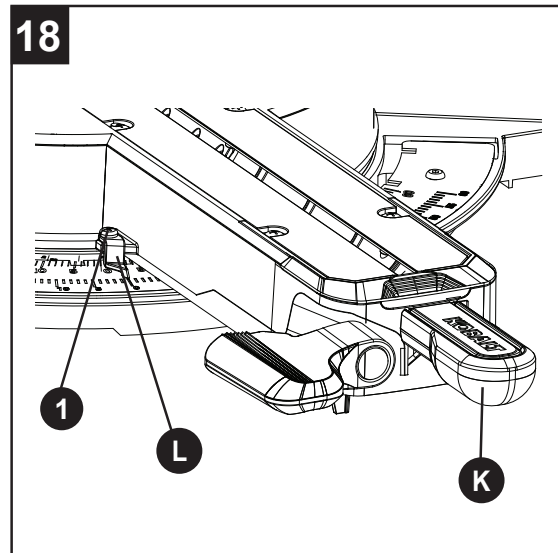

ADJUSTING FENCE SQUARENESS (FIG. 19)

- Remove both sliding fences (N) by loosening the sliding fence lock knobs (1).
 - Lower the cutting arm and lock in position.
 - Loosen the four fence locking bolts (2) using a 5 mm hex wrench.
 - Using a square (3), lay the heel of the square against the blade and the ruler against the sliding fence (N) as shown.
 - Adjust the fence to be 90° to the blade and tighten the four fence locking bolts (2).
- NOTE:** If the saw has not been used recently, recheck blade squareness to the fence and readjust if needed.
- After fence has been aligned, make a cut at 90° using a scrap of wood and check squareness on the piece. Readjust if necessary.

⚠ WARNING

Always make dry runs (unpowered) before finish cuts to check the path of the blade and the operation of the guards. Ensure the fence does not interfere with the action of the saw or guards.

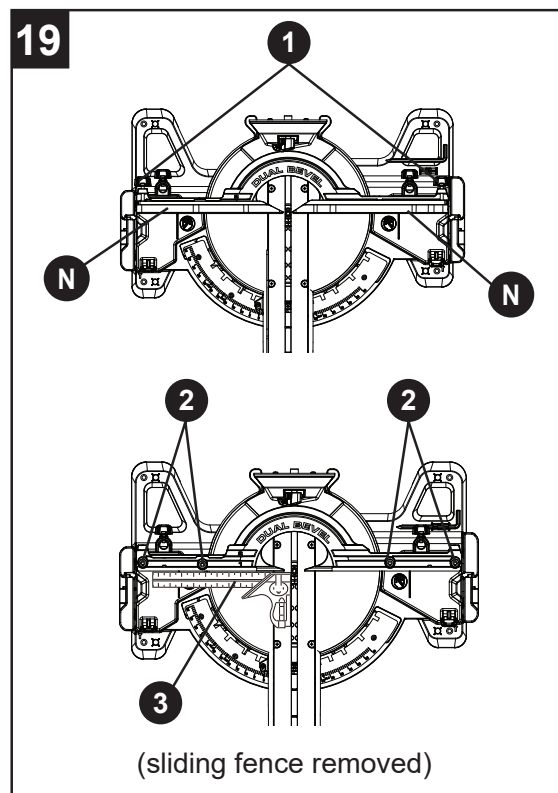

REMOVING OR INSTALLING THE SLIDING FENCE (FIG. 20)

At some extreme angles, the right or left side fence might have to be removed to ensure proper clearance prior to making the cut.

⚠ CAUTION

The right/left side sliding fence must be removed when making right/left bevel angle cuts greater than 33.9° in combination with any miter angle cuts greater than 31.6°.

- To remove the sliding fence, loosen the fence locking knob (1) by turning it counterclockwise, then slide the fence (N) out from the fence front position slot.
- To install the sliding fence, slide the fence into the fence front position slot (2), then lock the fence by turning the fence locking knob (1) clockwise.

NOTE: This miter saw is equipped to cut wide boards up to 16 in., see section “SLIDE CUTTING WIDE BOARDS” on page 31.

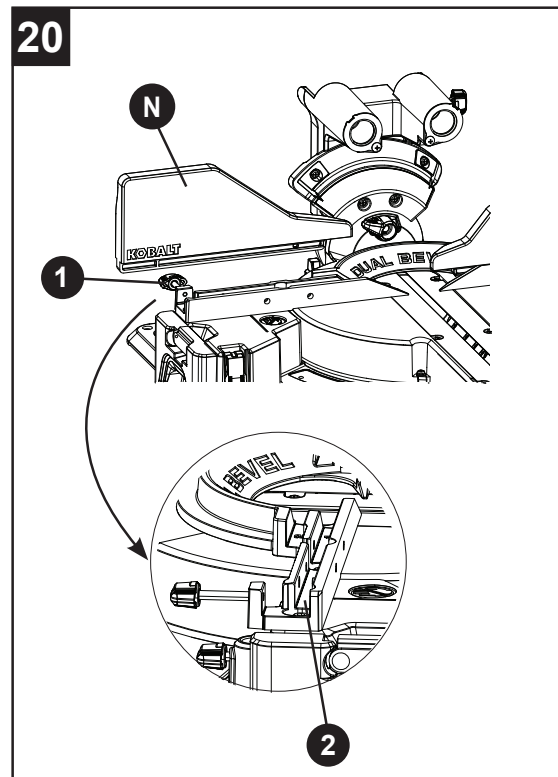

SETTING CUTTING DEPTH (FIG. 21)

The depth of cut can be preset for even and repetitive shallow cuts.

- Adjust the cutting head down until the teeth of the blade are at the desired depth.
- While holding the upper arm in that position, turn the stop knob (1) until it touches the stop plate (2).
- Recheck the blade depth by moving the cutting head front to back through the full motion of a typical cut along the control arm.

NOTE: Use a wooden spacer between the fence and the workpiece for a consistent depth through the cut. Use the hold-down clamp to secure the wooden spacer and workpiece firmly before making the cut.

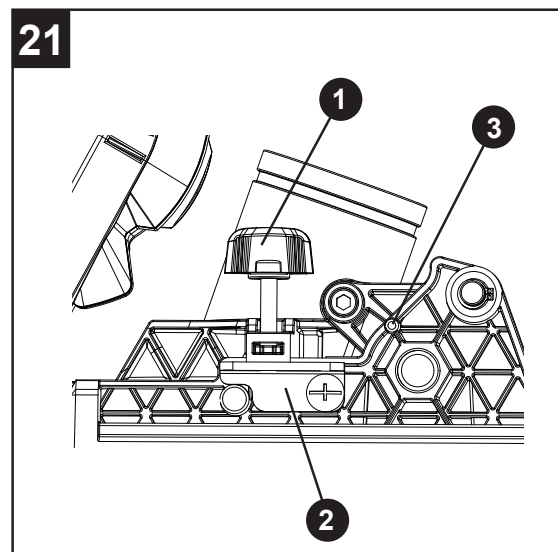

MAXIMUM CUTTING DEPTH (FIG. 21)

The maximum depth travel of the cutting head was set at the factory.

- Rotate the stop plate (2) clockwise to touch the stop rod (3).
- Recheck the blade depth by moving the cutting head front to back through the full motion of a typical cut along the control arm.

OPERATING INSTRUCTIONS

BEFORE USING THE MITER SAW

WARNING

To avoid mistakes that could cause serious, permanent injury, do not plug the tool in until the following steps are completed:

- Completely assemble and adjust the saw, following the instructions (SEE ASSEMBLY AND ADJUSTMENTS SECTIONS).
- Learn the use and function of the ON/OFF switch, upper and lower blade guards, stop latch, bevel lock handle and cover plate screws.
- Review and understand all safety instructions and operating procedures in this Operator's Manual (SEE SAFETY & OPERATIONS SECTIONS).
- Review the MAINTENANCE and TROUBLESHOOTING for your miter saw.
- To avoid injury or possible death from electrical shock, make sure your fingers do not touch the plug's metal prongs when plugging or unplugging your miter saw (SEE ELECTRICAL REQUIREMENTS AND SAFETY SECTIONS).

BEFORE EACH USE

Inspect your saw.

- Disconnect the miter saw. To avoid injury from accidental starting, unplug the saw before making any adjustments, including setup and blade changes.
- Compare the direction of rotation arrow on the guard to the direction arrow on the blade. The blade teeth should always point downward at the front of the saw.
- Tighten the arbor bolt.
- Tighten the cover plate screw.
- Check for damaged parts, including:
 - Alignment of moving parts
 - Damaged blade teeth
 - Damaged electric cords
 - Binding of moving parts
 - Broken/cracked castings: base, table, motor, upper arm
- Function of arm return spring and lower guard: Push the cutting arm all the way down and then let it rise until it stops. The lower guard should close fully. Follow the instructions in the Troubleshooting Guide for adjustment, if necessary.
- Keep all guards in place, in working order and properly adjusted. If any part of this miter saw is missing, damaged or broken, or any electrical parts do not work, turn off the saw and unplug it. Replace damaged, missing or defective parts before using the saw again.
- Maintain tools with care. Keep the miter saw clean for best and safest performance. Follow instructions for lubricating. Do not apply lubricants to the blade while it is spinning.
- Remove all adjusting wrenches from the tool before turning it on.

USE ONLY THE RECOMMENDED ACCESSORIES

- Follow the instructions that come with the accessory. The use of improper accessories may cause risk of injury to persons.
- Choose the correct 12 in. blade for the material and the type of cutting you plan to do.
- Make sure the blade is sharp, undamaged and properly aligned. With the saw unplugged, push the cutting arm all the way down. Manually spin the blade and check for clearance. Tilt the miter head to a 45° bevel and repeat the test.
- Make sure the blade and arbor collars are clean.
- Make sure all clamps and locks are tight and there is no excessive play in any parts.

KEEP YOUR WORK AREA CLEAN

Cluttered areas and benches invite accidents.

WARNING

To avoid burns or other fire damage, never use the miter saw near flammable liquids, vapors or gases.

- Plan ahead to protect your eyes, hands, face and ears.
- Read and understand the operator's manual and labels affixed to the tool. Learn its application and limitations as well as the potential hazards specific to this tool. To avoid injury from accidental contact with moving parts, do not layout, assemble or set up work on the miter saw.
- Avoid accidental starting. Make sure the switch is in the OFF position before plugging the miter saw into a power outlet.

PLAN YOUR WORK

Use the right tool. Do not force a tool or attachment to do a job it was not designed to do. Use a different tool for any workpiece that cannot be held in a solidly braced, fixed position.

WARNING

This machine is NOT designed for cutting masonry, masonry products or ferrous metals (steel, iron and iron-based metals). Use this miter saw to cut only wood and wood by-products. Other materials may shatter, bind the blade or create other dangers. Remove all nails that may be in the workpiece to prevent sparking that could cause a fire.

DRESS FOR SAFETY

Any power tool can throw foreign objects into the eyes. This can result in permanent eye damage. Everyday eyeglasses have only impact resistant lenses and are not safety glasses. Glasses or goggles not in compliance with ANSI Z87.1 could seriously injure you if they break.

- Do not wear loose clothing, gloves, neckties or jewelry (rings, watches). They can get caught and draw you into moving parts.
- Wear non-slip footwear.
- Tie back long hair.
- Roll long sleeves above the elbow.
- Noise levels vary widely. To avoid possible hearing damage, wear earplugs when using any miter saw.
- For dusty operations, wear a dust mask along with safety goggles.

INSPECT YOUR WORKPIECE

- Make sure there are no nails or foreign objects in the part of the workpiece being cut.
- Plan your work to avoid small pieces that may bind or are too small to clamp and hold securely.
- Plan the way you will grasp the workpiece from start to finish. Avoid awkward operations and hand positions. A sudden slip could cause your fingers or hand to move into the blade.

DO NOT OVERREACH

Keep good footing and balance. Keep your face and body to one side, out of the line of a possible kickback. NEVER stand in the line of the blade.

Never cut freehand:

- Brace your workpiece firmly against the fence and table stop so it will not rock or twist during the cut.
- Make sure there is no debris between the workpiece and the table or fence. Make sure there are no gaps between the workpiece, fence and table that will let the workpiece shift after it is cut.
- Keep the cut piece free to move sideways after it is cut off. Otherwise, it could get wedged against the blade and thrown violently.
- Only the workpiece should be on the saw table.
- Secure work. Use clamps or a vise to help hold the work when it is practical.

USE EXTRA CAUTION WITH LARGE OR ODD SHAPED WORKPIECES

- Use extra supports (tables, sawhorses, blocks, etc.) for workpieces large enough to tip.
- Never use another person as a substitute for a table extension or as an additional support for a workpiece that is longer or wider than the basic miter saw table, or to help feed, support or pull the workpiece.
- Do not use this saw to cut small pieces. If the workpiece being cut would cause your hand or fingers to be within 8-3/4 in. of the saw blade, the workpiece is too small. Keep hands and fingers out of the “no-hands zone” area marked on the saw table.
- When cutting odd shaped workpieces, plan your work so it will not bind in the blade and cause possible injury. Molding, for example, must lie flat or be held by a fixture or jig that will not let it move when cut.
- Properly support round material such as dowel rods or tubing, which have a tendency to roll when cut, causing the blade to “bite.”

WHEN SAW IS RUNNING** WARNING**

Do not allow familiarity from frequent use of your miter saw to result in a careless mistake. A careless fraction of a second is enough to cause severe injury.

Before cutting, if the saw makes an unfamiliar noise or vibrates, stop immediately. Turn the saw OFF. Unplug the saw. Do not restart until you find and correct the problem.

 WARNING

To ensure the blade path is clear of obstructions, always make a dry run of the cut without power before making any cuts on the workpiece.

BODY AND HAND POSITION (FIG. 22)

⚠ WARNING

Never place hands near the cutting area. Proper positioning of your body and hands when operating the miter saw will make cutting easier and safer. Keep children away. Keep all visitors at a safe distance from the miter saw. Make sure bystanders are clear of the saw and workpiece. Do not force the saw. It will do the job better and safer at its designed rate.

⚠ WARNING

Operator and all by-standers must wear proper safety goggles that comply with OSHA/ANSI requirements Z87.1.

Starting a cut:

- Place hands at least 8-3/4 in. away from the path of the blade – out of the “no-hands zone.”
- Hold workpiece firmly against the fence to prevent movement toward the blade.
- Turn the LED switch on for pre-alignment of your cut.
- With the power switch OFF, bring the saw blade down to the workpiece to see the cutting path of the blade. Raise the saw blade back up before turning the saw on.
- Squeeze trigger switch to start saw.
- Lower blade into workpiece with a firm downward motion.
- On wider boards, slide the cutting arm back toward fence to make the cut.

Finishing a cut:

- Hold the cutting arm in the down position.
- Release trigger switch and wait for all moving parts to stop before moving your hands and raising the cutting arm.
- If the blade doesn't stop within 5 seconds, unplug the saw and follow the instructions in TROUBLESHOOTING.

Before freeing jammed material:

- Release trigger switch.
- Wait for all moving parts to stop.
- Unplug the miter saw.

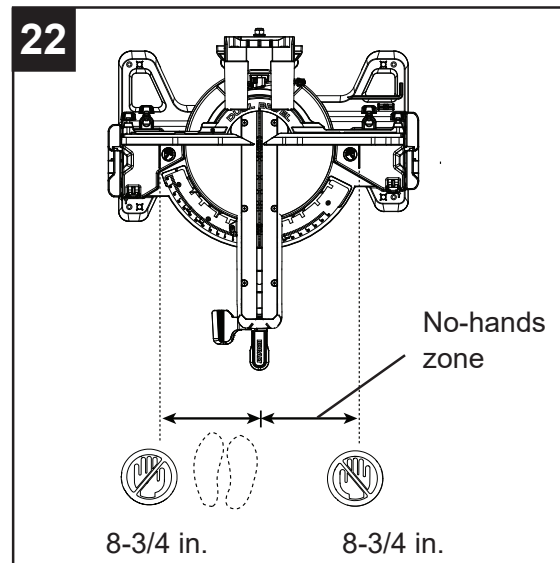

BASIC SAW OPERATIONS

⚠ WARNING

For your convenience, your saw has an electric brake. The brake is not a safety device. Never rely on it to replace the proper use of the guard on your saw. If the blade does not stop within 5 seconds, unplug the saw and follow the instructions in TROUBLESHOOTING.

TURNING THE LED LIGHT ON (FIG. 23)

Press the LED ON/OFF switch (1) to "ON" position to turn the light on.

The LED casts a shadow of the blade teeth onto the workpiece for making precision cuts and predicts blade kerf for blade cut line.

To use this feature, turn the LED ON/OFF switch (1) on. Bring the cutting head down, and the shadow of the blade will be projected onto the workpiece, indicating where the blade teeth will make contact as the cut is made.

TURNING THE SAW ON (FIG. 23)

This miter saw is equipped with a two step ON/OFF trigger switch. Press down on the yellow safety lock switch (2) and squeeze the trigger switch (3) to turn the miter saw ON.

NOTE: Make the ON/OFF switch childproof. Insert a padlock (not included) through the hole (4) in the trigger switch, locking the tool's switch and preventing children and other unauthorized users from turning the machine on.

The miter saw is equipped with an electric brake. When the trigger switch is released, the blade will be stopped within 5 seconds.

⚠ WARNING

- To avoid injury, after completing a cut and releasing the trigger switch, wait and confirm the blade has stopped before raising the cutting head.
- To avoid injury, check and tighten the arbor bolt periodically.

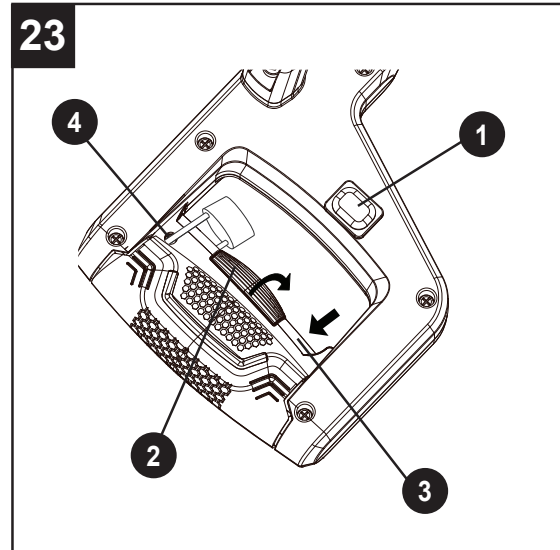

SLIDING CARRIAGE SYSTEM (FIG. 24)

⚠ CAUTION

To reduce the risk of injury, return carriage to the full rear position after each crosscut operation.

- For chop cutting operations on small workpieces, slide the cutting head assembly completely toward the rear of the unit and tighten the slide carriage lock knob (T).
- To cut wide boards up to 14 in., the carriage lock knob must be loosened to allow the cutting head to slide freely.

NOTE: Please refer to the section of “SLIDE CUTTING WIDE BOARDS” on page 31 to cut boards wider than 14 in.

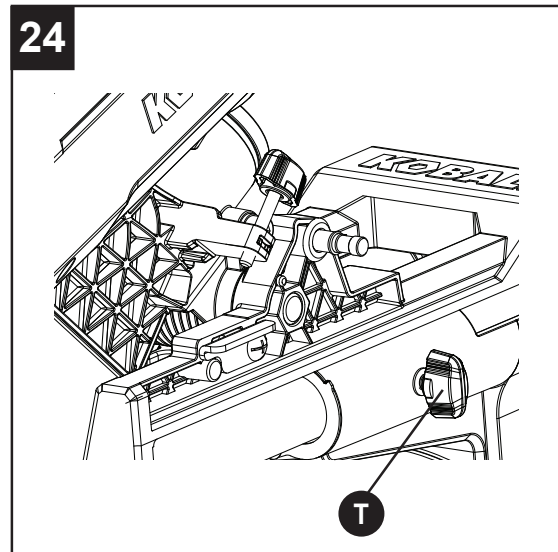

SLIDING FENCE (FIG. 25)

⚠ WARNING

The sliding fence must be extended when making any bevel cut. Failure to extend the sliding fence will not allow enough space for the blade to pass through, which could result in serious injury. At extreme miter or bevel angles, the saw blade may also contact the fence.

- Loosen the fence locking knob (1) by turning it counterclockwise, then slide the fence (N) out.
- Tighten the fence locking knob (1).

NOTE: When transporting the saw, always secure the sliding fence in the inward position and locked.

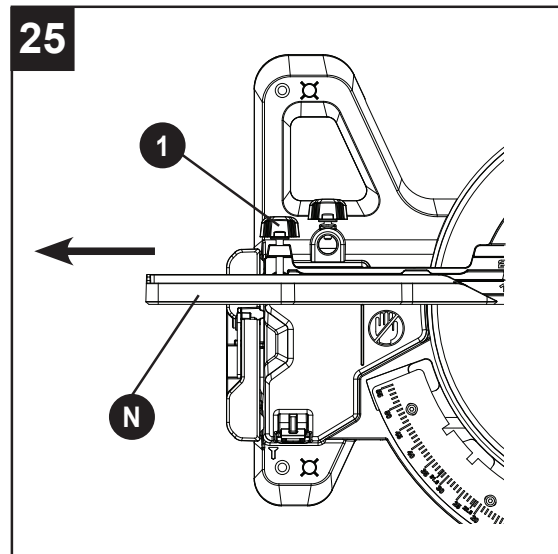

BEFORE LEAVING THE SAW

- Never leave tool running unattended. Turn power OFF. Wait for all moving parts to stop.
- Make workshop childproof. Lock the shop. Disconnect master switches. Store tool away from children and other unqualified users.

⚠ WARNING

To avoid injury from materials being thrown, always unplug the saw to avoid accidental starting and remove small pieces of material from the table cavity.

MITER CUT (FIG. 26)

- When a miter cut is required, unlock the miter table by lifting up the miter lock handle (K).
- Rotate the miter table to the right or left with the miter handle.
- When the table is in the desired position, as shown on the miter scale (1), pressing down the miter handle to make it in a horizontal position to tighten the miter table. The table is now locked at the desired angle. Positive stops are provided at 0°, 15°, 22.5°, 31.6°, 45° left and right, 55° left and 60° right.
- Turn the LED switch on and position the workpiece on the table for pre-alignment of your cut.

IMPORTANT: Always tighten the miter table lock handle before performing every cutting operation.

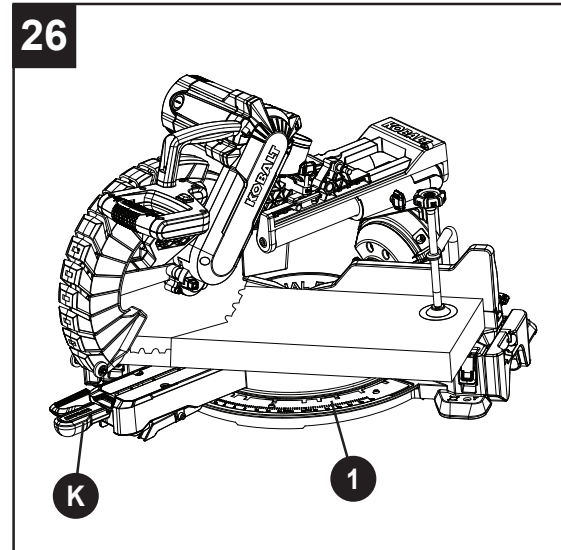

BEVEL CUT (FIG. 27)

⚠ WARNING

The sliding fence must be extended when making any bevel cut. Failure to extend the sliding fence will not allow enough space for the blade to pass through which could result in serious injury. At extreme miter or bevel angles, the saw blade may also contact the fence.

⚠ WARNING

The right/left side sliding fence must be removed when making any bevel angle cuts greater than 33.9° in combination with any miter angle cuts greater than 31.6°.

- When a bevel cut is required, loosen the bevel lock handle (Z) by turning it clockwise.
- Tilt the cutting head to the desired angle, as shown on the bevel scale (U).
- The blade can be positioned at any angle, from a 90° straight cut (0° on the scale) to a 48° left/right bevel. Tighten the bevel lock handle (Z) to lock the cutting head in position. Positive stops are provided at 0° and 45°.
- Turn the LED switch on and position the workpiece on the table for pre-alignment of your cut.

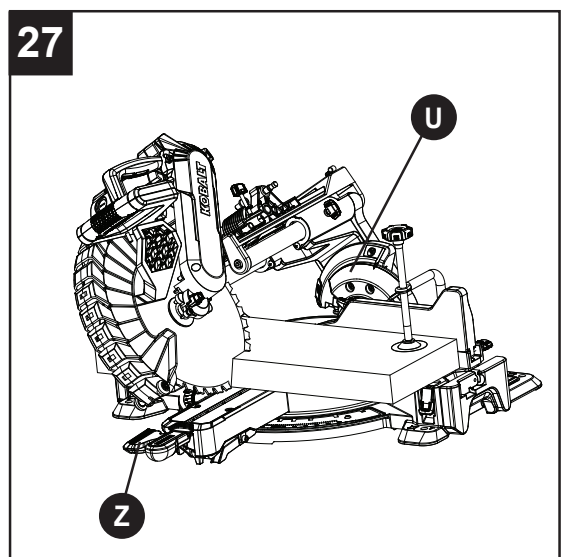

COMPOUND CUT (FIG. 28)

⚠ WARNING

The right/left side sliding fence must be removed when making any bevel angle cuts greater than 33.9° in combination with any miter angle cuts greater than 31.6°.

A compound cut is the combination of a miter and a bevel cut simultaneously.

- Extend the sliding fence as described in “SLIDING FENCE” section on page 29.
- Loosen the bevel lock handle (Z) and position the cutting head at the desired bevel position. Lock the bevel lock handle (Z).
- Loosen the miter lock handle (K) by lifting it up. Position the table at the desired miter angle. Lock the miter lock handle (K) by pressing it down.
- Turn the LED switch on and position the workpiece on the table for pre-alignment of your cut.

28

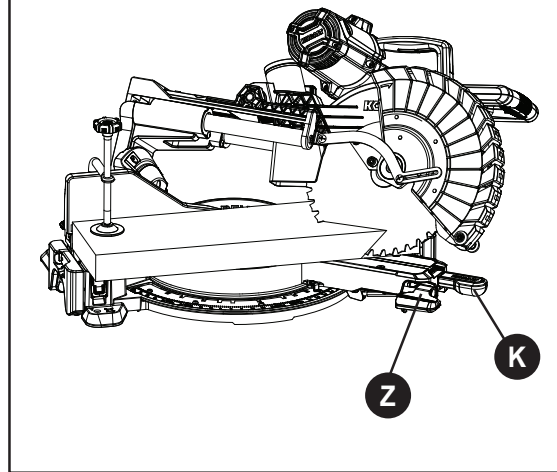

SLIDE CUTTING WIDE BOARDS (FIG. 29)

⚠ CAUTION

Always use a work clamp to maintain control and reduce the risk of workpiece damage and personal injury.

To avoid injury:

- Let the blade reach full speed before cutting. This will help reduce the risk of a thrown workpiece.
- Do not make crosscuts by lowering the blade and pulling the saw head through the wood toward you. The blade may try to climb up on top of the workpiece, causing the cutting assembly and spinning blade to kick back forcefully.

29

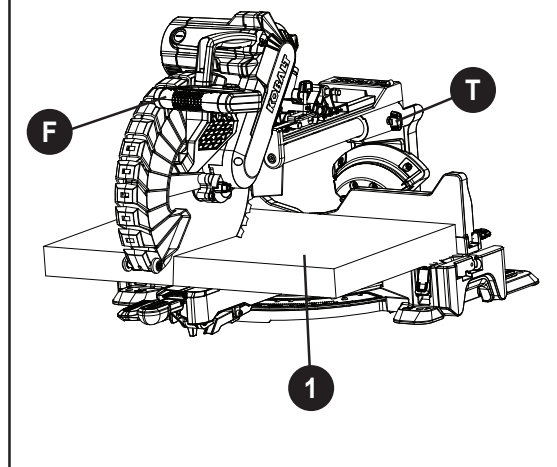

To slide cut wide boards (Fig. 29)

- Unlock the slide carriage lock knob (T) and allow the cutting head assembly to move freely.
- Set both the desired bevel angle and/or the miter angle and lock into position.
- Use a hold down clamp to secure the workpiece (1).
- Grasp the switch handle (F) and pull forward until the center of the saw blade is over the front of the workpiece (1).
- Engage the trigger to turn the saw on.
- When the saw reaches full speed, slowly push the saw handle down, cutting through the leading edge of the workpiece (1).
- Slowly move the saw handle back toward the fence, completing the cut.
- Release the trigger and allow the blade to stop spinning before raising the cutting head and removing the workpiece (1).

FENCE SET UP FOR WIDE CROSSCUTS (FIG. 30, 31)

This saw can cut dimensional lumber up to 2 x 16 in. when the fence is placed in its back position. Please follow the below steps for this fence set up.

⚠ WARNING

To avoid injury from an accidental start, make sure the switch is in the OFF position and the plug is not connected to the power source outlet.

NOTE: Make sure the miter angle is set at 0 degree.

- Remove the left and right side sliding fences from their forward position (1) by loosening the locking knobs (2) and sliding each fence outward.
- Using a 2 in. x 14 in. board, make an auxiliary table. Place this board on top of the saw table and flush against the lower fence section. This board must be flat, otherwise the cutting material could move during operation and cause injury.
- Securely attach this auxiliary table to the lower fence section using four wood screws as shown in Fig. 31 through the holes in the back fence.
- Slide the two fences into the rear position (3). Tighten the two fence locking knobs.

⚠ WARNING

Always make dry runs (unpowered) before finish cuts to check the path of the blade and the operation of the guards. Ensure the fence does not interfere with the action of the saw or guards.

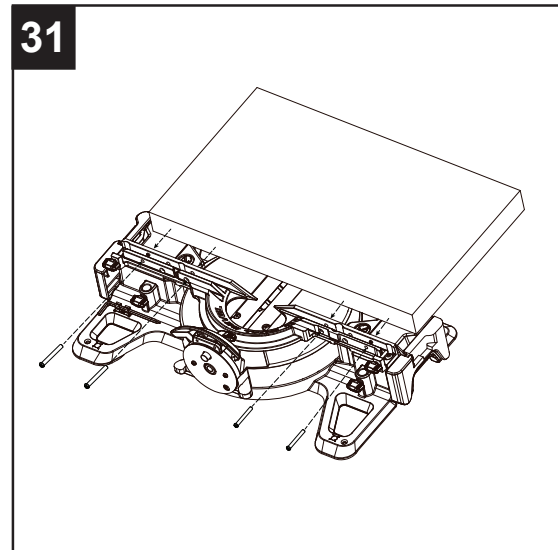
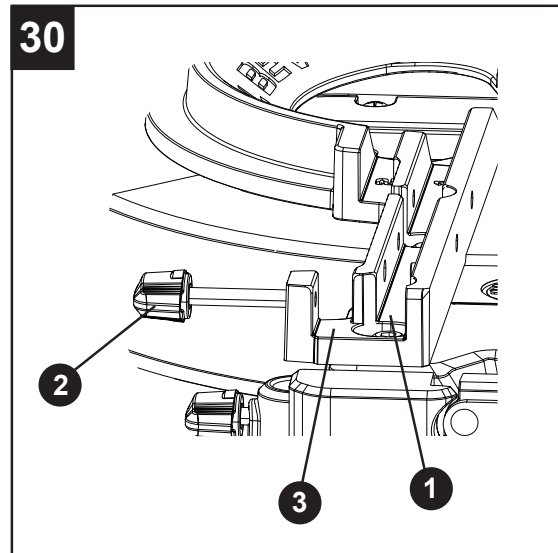

CUTTING BOWED MATERIAL (FIG. 32)

A bowed workpiece must be positioned against the fence and secured with a clamp (B) before cutting as shown. Do not position workpiece incorrectly or try to cut the workpiece without the support of the fence. This will cause the blade to bind and could result in personal injury.

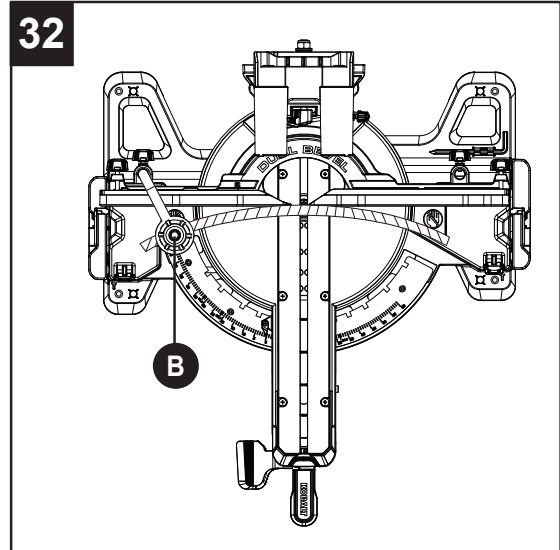

CUTTING GROOVES (FIG. 33)

⚠ WARNING

DO NOT USE A DADO BLADE, use only the standard 12 in. diameter saw blade for this operation.

- Mark lines to identify the width and depth of the desired cut on the workpiece and put the workpiece on the table and aim the inside tip of the blade at the line. Use a clamp to secure the workpiece on the table.
- Lower the cutting head to the depth marked on the workpiece, holding the upper arm and adjust the stop knob (1) until it touches the stop plate (2).
- Cut two parallel grooves as shown in Fig. 33.

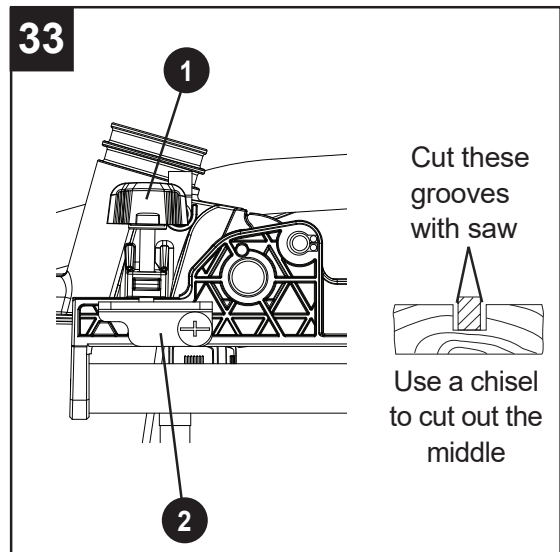

WORKPIECE SUPPORT (FIG. 34)

NOTE: Long pieces need extension wing support.

- Lift up the lock lever (J) to unlock the extension table. Slide the extension wing to desired position and push down the lock lever (J) to tighten. If the lock lever (J) is not tight enough, adjust the nuts (1) located underneath the base 1/4 turn counterclockwise.

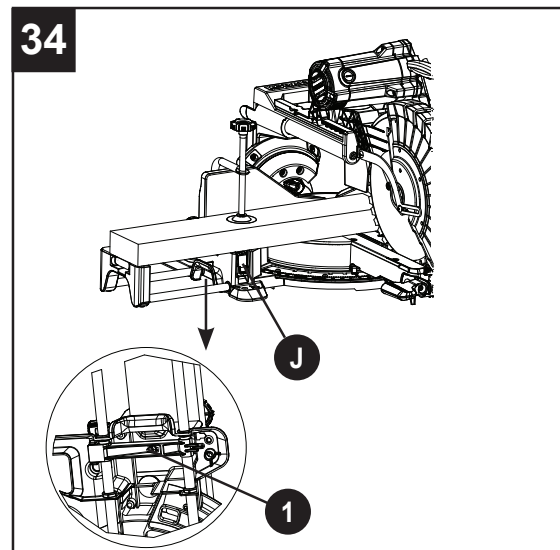

AUXILIARY WOOD FENCE (FIG. 35)

When making multiple or repetitive cuts that result in cut-off pieces of one inch or less, it is possible for the saw blade to catch the cut-off piece and throw it out of the saw or into the blade guard and housing, possibly causing damage or injury. To minimize this, an auxiliary wood fence can be mounted to your saw. Holes are provided in the saw fence to attach an auxiliary wood fence (this provides additional depth of cut). This fence should be constructed of straight auxiliary wood approximately 3/4 in. thick by 2-1/2 in. high by 22 in. long. Attach the wood fence securely and make a full depth cut to make a blade slot. Check for interference between the wood fence and the lower blade guard. Adjust if necessary.

NOTE: This auxiliary fence is used only with the saw blade in the 0° bevel position (90° to the table). The auxiliary wood fence must be removed when bevel cutting.

CUTTING BASE MOLDING (FIG. 36)

Base moldings and many other moldings can be cut on a compound miter saw. The setup of the saw depends on molding characteristics and applications, as shown. Perform practice cuts on scrap material to achieve best results:

- Always make sure moldings rest firmly against the fence and table. Use hold-down or C-clamps, whenever possible, and place tape on the area being clamped to avoid marks.
- Reduce splintering by taping the cut area prior to making cut. Mark cut line directly on the tape.
- Splintering typically happens due to wrong blade application and thinness of the material.

NOTE: Always perform a dry run cut so you can determine if the operation being attempted is possible before power is applied to the saw.

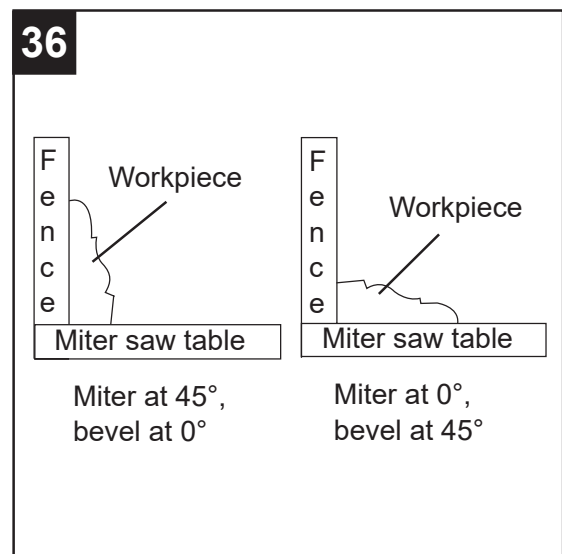
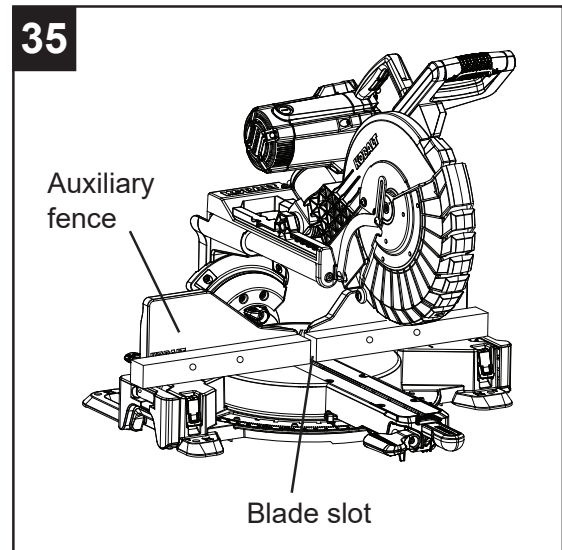

CUTTING CROWN MOLDING (FIG. 37, 38)

Your compound miter saw is suited for the difficult task of cutting crown molding. To fit properly, crown molding must be compound-mitered with extreme accuracy. The two surfaces on a piece of crown molding that fit flat against the ceiling and wall are at angles that, **when added together, equal exactly 90°.**

Most crown molding has a top rear angle (the section that fits flat against the ceiling) of 52° and a bottom rear angle (the section that fits flat against the wall) of 38°.

In order to accurately cut crown molding for a **90° inside or outside corner**, lay the molding with its broad back surface flat on the saw table.

When setting the bevel and miter angles for compound miters, remember the settings are interdependent; changing one changes the other, as well.

37

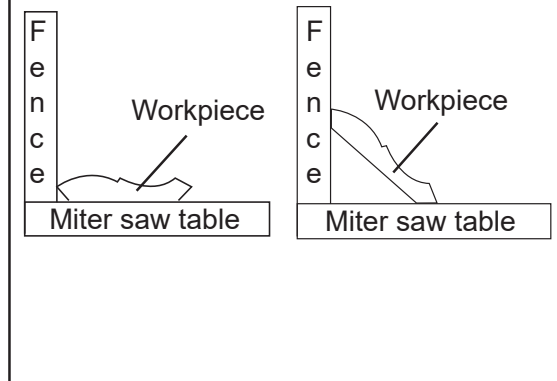

38

Settings for standard crown molding lying flat on compound miter saw table

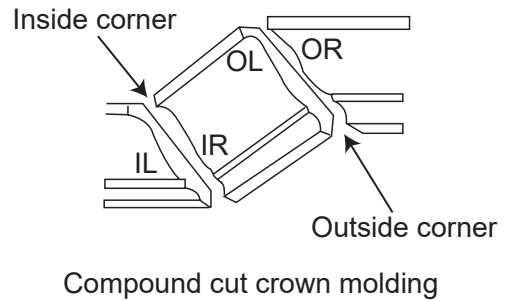

See the next page for settings chart

Bevel/Miter Settings

NOTE: The chart below references a compound cut for crown molding ONLY WHEN THE ANGLE BETWEEN THE WALLS EQUALS 90°.

KEY	BEVEL SETTING	MITER SETTING	TYPE OF CUT
Inside corner - Left side			
IL	33.9°	31.6° Right	1. Position top of molding against fence. 2. Miter table set at RIGHT 31.6°. 3. LEFT side is finished piece.
Inside corner - Right side			
IR	33.9°	31.6° Left	1. Position bottom of molding against fence. 2. Miter table set at LEFT 31.6°. 3. LEFT side is finished piece.
Outside corner - Left side			
OL	33.9°	31.6° Left	1. Position bottom of molding against fence. 2. Miter table set at LEFT 31.6°. 3. RIGHT side is finished piece.
Outside corner - Right side			
OR	33.9°	31.6° Right	1. Position top of molding against fence. 2. Miter table set at RIGHT 31.6°. 3. RIGHT side is finished piece.

CROWN MOLDING CHART

Compound Miter Saw

Miter and Bevel Angle Settings

Wall to Crown Molding Angle

Angle Between Walls	52/38° Crown Molding		45/45° Crown Molding	
	Miter Setting	Bevel Setting	Miter Setting	Bevel Setting
67	42.93	41.08	46.89	36.13
68	42.39	40.79	46.35	35.89
69	41.85	40.50	45.81	35.64
70	41.32	40.20	45.28	35.40
71	40.79	39.90	44.75	35.15
72	40.28	39.61	44.22	34.89
73	39.76	39.30	43.70	34.64
74	39.25	39.00	43.18	35.38
75	38.74	38.69	42.66	34.12
76	38.24	38.39	42.15	33.86
77	37.74	38.08	41.64	33.60
78	37.24	37.76	41.13	33.33
79	36.75	37.45	40.62	33.07
80	36.27	37.13	40.12	32.80
81	35.79	36.81	39.62	32.53
82	35.31	36.49	39.13	32.25
83	34.83	36.17	38.63	31.98
84	34.36	35.85	38.14	31.70
85	33.90	35.52	37.66	31.42
86	33.43	35.19	37.17	31.34
87	32.97	34.86	36.69	30.86
88	32.52	34.53	36.21	30.57
89	32.07	34.20	35.74	30.29
90	31.62	33.86	35.26	30.00
91	31.17	33.53	34.79	29.71
92	30.73	33.19	34.33	29.42
93	30.30	32.86	33.86	29.13
94	29.86	32.51	33.40	28.83
95	29.43	32.17	32.94	28.54
96	29.00	31.82	32.48	28.24
97	28.58	31.48	32.02	27.94
98	28.16	31.13	31.58	27.64
99	27.74	30.78	31.13	27.34
100	27.32	30.43	30.68	27.03
101	26.91	30.08	30.24	26.73
102	26.50	29.73	29.80	26.42
103	26.09	29.38	29.36	26.12
104	25.69	29.02	28.92	25.81
105	25.29	28.67	28.48	25.50
106	24.89	28.31	28.05	25.19
107	24.49	27.96	27.62	24.87
108	24.10	27.59	27.19	24.56
109	23.71	27.23	26.77	24.24
110	23.32	26.87	26.34	23.93
111	22.93	26.51	25.92	23.61
112	22.55	26.15	25.50	23.29
113	22.17	25.78	25.08	22.97
114	21.79	25.42	24.66	22.66
115	21.42	25.05	24.25	22.33
116	21.04	24.68	23.84	22.01
117	20.67	24.31	23.43	21.68
118	20.30	23.94	23.02	21.36
119	19.93	23.57	22.61	21.03
120	19.57	23.20	22.21	20.70
121	19.20	22.83	21.80	20.38
122	18.84	22.46	21.40	20.05

Angle Between Walls	52/38° Crown Molding		45/45° Crown Molding	
	Miter Setting	Bevel Setting	Miter Setting	Bevel Setting
123	18.48	22.09	21.00	19.72
124	18.13	21.71	20.61	19.39
125	17.77	21.34	20.21	19.06
126	17.42	20.96	19.81	18.72
127	17.06	20.59	19.42	18.39
128	16.71	20.21	19.03	18.06
129	16.37	19.83	18.64	17.72
130	16.02	19.45	18.25	17.39
131	15.67	19.07	17.86	17.05
132	15.33	18.69	17.48	16.71
133	14.99	18.31	17.09	16.38
134	14.66	17.93	16.71	16.04
135	14.30	17.55	16.32	15.70
136	13.97	17.17	15.94	15.36
137	13.63	16.79	15.56	15.02
138	13.30	16.40	15.19	14.62
139	12.96	16.02	14.81	14.34
140	12.63	15.64	14.43	14.00
141	12.30	15.25	14.06	13.65
142	11.97	14.87	13.68	13.31
143	11.64	14.48	13.31	12.97
144	11.31	14.09	12.94	12.62
145	10.99	13.71	12.57	12.29
146	10.66	13.32	12.20	11.93
147	10.34	12.93	11.83	11.59
148	10.01	12.54	11.46	11.24
149	9.69	12.16	11.09	10.89
150	9.37	11.77	10.73	10.55
151	9.05	11.38	10.36	10.20
152	8.73	10.99	10.00	9.85
153	8.41	10.60	9.63	9.50
154	8.09	10.21	9.27	9.15
155	7.77	9.82	8.91	8.80
156	7.46	9.43	8.55	8.45
157	7.14	9.04	8.19	8.10
158	6.82	8.65	7.83	7.75
159	6.51	8.26	7.47	7.40
160	6.20	7.86	7.11	7.05
161	5.88	7.47	6.75	6.70
162	5.57	7.08	6.39	6.35
163	5.26	6.69	6.03	6.00
164	4.95	6.30	5.68	5.65
165	4.63	5.90	5.32	5.30
166	4.32	5.51	4.96	4.94
167	4.01	5.12	4.61	4.59
168	3.70	4.72	4.25	4.24
169	3.39	4.33	3.90	3.89
170	3.08	3.94	3.54	3.53
171	2.77	3.54	3.19	3.10
172	2.47	3.15	2.83	2.83
173	2.15	2.75	2.48	2.47
174	1.85	2.36	2.12	2.12
175	1.54	1.97	1.77	1.77
176	1.23	1.58	1.41	1.41
177	0.92	1.18	1.06	1.06
178	0.62	0.79	0.71	0.71
179	0.31	0.39	0.35	0.35

CARE AND MAINTENANCE

⚠ WARNING

- To avoid fire or toxic reaction, never use gasoline, naphtha, acetone, lacquer thinner or similar highly volatile solvents to clean the miter saw.
- To avoid injury from unexpected starting or electrical shock, unplug the power cord before working on the saw.
- For your safety, this saw is double insulated. To avoid electrical shock, fire or injury, use only parts identical to those identified in the parts list. Reassemble exactly to avoid electrical shock.

REPLACING CARBON BRUSHES (FIG. 39)

The carbon brushes (P) furnished will last approximately 50 hours of running time, or 10,000 ON/OFF cycles. Replace both carbon brushes when either has less than 1/4 in. length of carbon remaining, or if the spring or wire is damaged or burned. To inspect or replace brushes, first unplug the saw. Remove the black plastic cap (1) on the side of the motor (Q). Carefully remove the spring-loaded cap. Pull out the brush and replace. Replace for the other side. Reverse the procedure for reassembly. Press the metal part of the carbon brush into the hole where the carbon part fits. Tighten the cap snugly but do not overtighten.

NOTE: To reinstall the same brushes, first make sure the brushes go back in the way they came out. This will avoid a break-in period that reduces motor performance and increases wear.

LOWER BLADE GUARD (FIG. 40)

Do not use the saw without the lower blade guard. The lower blade guard is attached to the saw for your protection. Should the lower guard become damaged, do not use the saw until the damaged guard has been replaced. Check regularly to make sure the lower guard is working properly. Clean the lower guard of any dust or buildup with a damp cloth.

⚠ CAUTION

- Do not use solvents on the guard. They could make the plastic cloudy and brittle.
- When cleaning the lower guard, unplug the saw to avoid unexpected start-up.

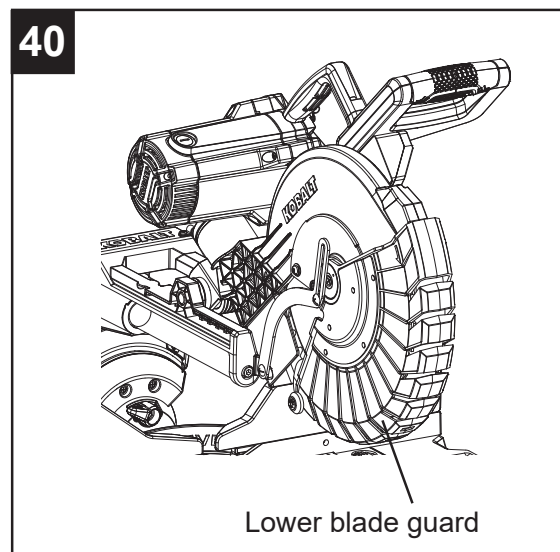
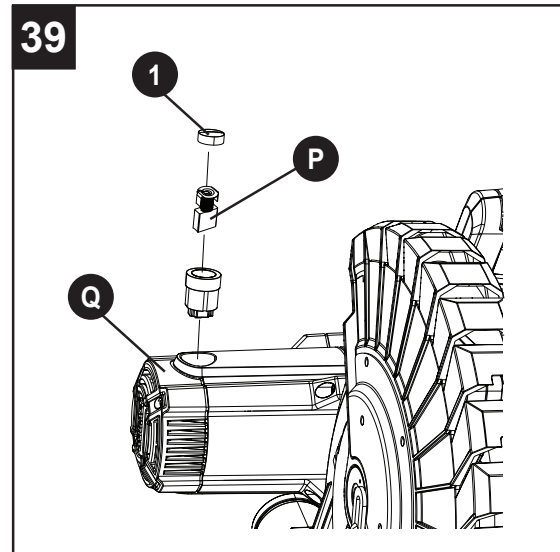

SAWDUST

Periodically, sawdust will accumulate under the worktable and base. This could cause difficulty in the movement of the worktable when setting up a miter cut. Frequently blow out or vacuum up the sawdust.

CAUTION

If blowing sawdust, wear proper eye protection to keep debris from blowing into eyes.

FREE WARNING LABEL REPLACEMENT: If your warning labels become illegible or are missing, call 888-356-2258 for a free replacement.

WARNING

DO NOT replace the power cord. If you have any problem or questions concerning the power cord, call the Customer Service Department at 888-356-2258.

12-IN COMPACT SLIDING DUAL-BEVEL MITER SAW #5034337
SIERRA INGLETADORA COMPACTA DESLIZABLE DE BISEL DOBLE DE 30,48 CM

BLADE/HOJA
15A, 4,200min⁻¹ (RPM) [NO LOAD] 120V a.c. 60Hz
15 AMPERIOS, 4200 RPM (SIN CARGA) 120 V AC.- 60 HZ

 DOUBLE INSULATED- WHEN SERVICING, USE ONLY IDENTICAL REPLACEMENT PARTS
AISLAMIENTO DOBLE: AL REPARAR, UTILICE SOLO PIEZAS DE REPUESTO IDENTICAS

SERIAL NO.: MFG. DATE:
SERIE NO.: FECHA DE FABRICACIÓN:

888-356-2258 (888-3KOBALT)
DISTRIBUTED BY/DISTRIBUIDO POR:
LOWE'S HOME CENTERS LLC
1000 LOWE'S BLVD.
MOORESVILLE, NC 28117

REXON INDUSTRIAL CORP., LTD.
261, JEN HWA ROAD, TALI, TAICHUNG, TAIWAN
RTX

 LISTED
37J2
E82443

MADE IN CHINA/HECHO EN CHINA

WARNING

TO REDUCE THE RISK OF INJURY, USER MUST READ INSTRUCTION MANUAL

1. Wear eye protection.
2. Keep hands and body out of the path of the saw blade. Contact with blade will result in serious injury.
3. Check guarding system to make sure it is functioning correctly.
4. Do not perform any operation freehand.
5. Never reach around saw blade.
6. Turn off tool and wait for saw blade to stop before moving workpiece or changing settings.
7. Wear respiratory and hearing protection.
8. Disconnect power before changing blade or servicing.
9. Use only blades that are 12 in. diameter and have a maximum RPM speed greater than 4,200min⁻¹ (RPM) (no load on this saw is 4,200min⁻¹ (RPM)).
10. Do not expose to rain or use in damp locations.
11. Tighten arbor screw and clamps before sawing.
12. Secure tool properly to prevent unexpected movement.
13. Failure to comply with these warnings may result in serious personal injury.

ADVERTENCIA

PARA REDUCIR EL RIESGO DE LESIONES, EL USUARIO DEBE LEER EL MANUAL DE INSTRUCCIONES

1. Utilice protección para los ojos.
2. Mantenga las manos y el cuerpo alejados del camino que recorre la hoja de la sierra. El contacto con la hoja podría provocar lesiones graves.
3. Verifique el sistema de protección para asegurarse de que funciona correctamente.
4. No realice ninguna operación sin utilizar las manos.
5. Nunca intente tocar el área alrededor de la hoja de la sierra.
6. Apague la herramienta y espere que la hoja de la sierra se detenga antes de mover las piezas de trabajo o de cambiar la configuración.
7. Utilice protección para los oídos y las vías respiratorias.
8. Desconecte la fuente de alimentación antes de la limpieza o el mantenimiento.
9. Utilice hojas de sólo de 30,5 cm de diámetro y que tengan una velocidad máxima mayor a 4200 RPM (ninguna carga en esta sierra es de 4200 RPM).
10. No exponga esta herramienta a la lluvia ni la utilice en áreas húmedas.
11. Apriete el tornillo del husillo y las abrazaderas antes de usar la sierra.
12. Asegure la herramienta adecuadamente para evitar un movimiento inesperado.
13. El no cumplir con estas advertencias podría ocasionar lesiones personales graves.

TROUBLESHOOTING

WARNING

To avoid injury from accidental starting, always ensure switch is in the OFF position and unplug the tool before moving, replacing the blade or making adjustments.

TROUBLESHOOTING – MOTOR

PROBLEM	POSSIBLE CAUSE	CORRECTIVE ACTION
Blade does not stop within 5 seconds.	<ol style="list-style-type: none"> 1. Motor brushes not sealed or lightly sticking. 2. Motor brake overheated from use of defective or wrong size blade or rapid ON/OFF cycling. 3. Arbor bolt loosened. 4. Other. 	<ol style="list-style-type: none"> 1. Inspect, clean and/or replace brushes. See MAINTENANCE section. 2. Use the recommended blade. Allow to cool down. 3. Retighten the arbor bolt. 4. Contact customer service.
Motor does not start.	<ol style="list-style-type: none"> 1. Blown fuse. 2. Worn brush. 3. Other. 	<ol style="list-style-type: none"> 1. Use and check the 20A time-delay fuse or the circuit breaker. 2. See MAINTENANCE section. 3. Contact customer service.
Excessive brush spark when the switch is released.	<ol style="list-style-type: none"> 1. Brush worn. 	<ol style="list-style-type: none"> 1. Replace brushes.

TROUBLESHOOTING – SAW OPERATION

PROBLEM	POSSIBLE CAUSE	CORRECTIVE ACTION
Blade hits table.	<ol style="list-style-type: none"> 1. Misalignment. 	<ol style="list-style-type: none"> 1. See ADJUSTMENT section.
Angle of cut not accurate. Cannot adjust miter.	<ol style="list-style-type: none"> 1. Miter table locked. 2. Sawdust under table. 	<ol style="list-style-type: none"> 1. Push positive stop locking lever down and rotate table. See OPERATING INSTRUCTIONS section. 2. Vacuum or blow out dust. WEAR EYE PROTECTION.
Cutting arm wobbles.	<ol style="list-style-type: none"> 1. Loose pivot points. 	<ol style="list-style-type: none"> 1. See ADJUSTMENT INSTRUCTIONS section.
Cutting arm will not fully raise or blade guard will not fully close.	<ol style="list-style-type: none"> 1. Part failure. 2. Pivot spring not replaced properly after service. 3. Sawdust build-up. 	<ol style="list-style-type: none"> 1. Contact customer service. 2. Contact customer service. 3. See CARE AND MAINTENANCE section.
Blade binds, jams, burns wood.	<ol style="list-style-type: none"> 1. Improper operation. 2. Dull blade. 3. Improper blade size. 4. Warped blade. 	<ol style="list-style-type: none"> 1. See BASIC SAW OPERATIONS section. 2. Replace or sharpen blade. 3. Replace with 12 in. diameter blade. 4. Replace blade.
Saw vibrates or shakes.	<ol style="list-style-type: none"> 1. Saw blade not round. 2. Saw blade damaged. 3. Saw blade loose. 4. Saw blade warped. 	<ol style="list-style-type: none"> 1. Replace blade. 2. Replace blade. 3. Tighten arbor bolt. 4. Replace blade.

REPLACEMENT PARTS LIST

For replacement parts, call our customer service department at 888-3KOBALT (888-356-2258), 8 a.m. - 8 p.m., EST, Monday - Sunday. You could also contact us at partsplus@lowes.com.

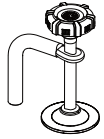

B

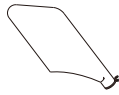

C



D



E



H



K



N



P

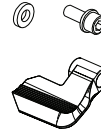

Z

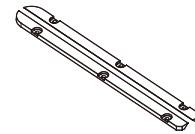

AA

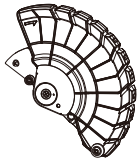

DD

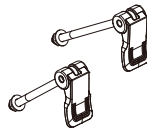

EE

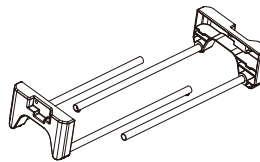

FF



GG

PART	DESCRIPTION	PART #
B	Hold-down clamp	3VMS
C	Dust bag	3YSA
D	Blade wrench	3VJN
E	Carrying handle	3TPS
H	Fence	3TN1
K	Miter lock handle	47MF
N	Sliding fences (set of 2)	3YW2 (Left) / 3YVZ (Right)
P	Carbon burshes (set of 2)	0QQT
Z	Bevel lock handle	3X3B
AA	Table inserts (set of 2)	3TP1 (Left) / 3TP0 (Right)
DD	Blade guard assembly	51R8
EE	Extension locks assembly (set of 2)	51RB
FF	Extension wings assembly (set of 2)	51R9 (Left) / 51RA (Right)
GG	Manual	508C

DISTRIBUTED BY:
Lowe's Home Centers LLC
 1000 Lowe's Blvd., Mooresville, NC 28117

PAGE INTENTIONALLY LEFT BLANK

PAGE INTENTIONALLY LEFT BLANK

WARRANTY

The manufacturer will offer replacement parts for this product which under normal usage have proven to be defective in their manufacture or workmanship for a period of THREE (3) years from the date of initial retail purchase. This warranty is valid only to the original purchaser. This warranty is not transferable and does not cover any parts that have been subjected to misuse, abuse, alteration, overload, accident or normal wear of moving parts. Tools that have been sold "as is," sold reconditioned or used as rental equipment are not covered.

Warranty replacement parts can be obtained by contacting the manufacturer at 888-3KOBALT. Only the manufacturer is authorized to perform warranty service on this product. This warranty does not apply to accessories or damage caused where repairs have been made or attempted by others.

The manufacturer is not responsible for direct, indirect, incidental or consequential damages. Some states do not allow limitations on how long an implied warranty lasts and/or do not allow the exclusion or limitation of incidental damages, so the above limitations may not apply to you. This warranty gives you specific legal rights, and you may also have other rights, which vary from state to state.

The manufacturer makes no warranties, representations or promises as to the quality of its power tools other than those specially stated in this warranty.

WARRANTY VOID IF PRODUCT USED FOR COMMERCIAL PURPOSES.

For replacement parts, call our customer service department at 888-3KOBALT (888-356-2258).

Manufacturer
REXON INDUSTRIAL CORP., LTD.
261, Jen Hwa Road, Tali,
Taichung, Taiwan
Printed in China