

## **WARNING**

**ALWAYS MEASURE START WINDING CURRENT ON START-UP!  
NORMALLY 2 to 10 AMPS (See Page 5 for Details)  
AND  
BEFORE A SUSPECT COMPRESSOR IS REMOVED, ALWAYS  
CHECK LOCKED ROTOR PULL-DOWN VOLTAGE  
(See Page 2 for Details)**

# **A, B & J SERIES**

**INSTALLATION AND SERVICE INSTRUCTIONS  
REFRIGERATION AIR CONDITIONING/HEAT PUMP COMPRESSORS**



**CAUTION: Bristol compressors are completely interchangeable with other manufacturers. However, electrical specifications, tubing configurations, and wiring connections may vary. Before installing and starting this compressor, you must review the wiring diagrams and check for correct electrical components.**

**BRISTOL COMPRESSORS INTERNATIONAL, INC.**

15185 Industrial Park Road • Bristol, VA 24202

(276) 466-4121

FAX (276) 645-2423

[www.bristolcompressors.com](http://www.bristolcompressors.com)

**WARNING:** Read all procedures and warnings prior to performing maintenance! For your safety, it is essential that you use properly sized and operating test equipment.

**WARNING:** Air conditioning and refrigeration systems are pressurized; hazards could exist resulting in personal injury. It is therefore recommended that the following steps for troubleshooting, removal and installation of the hermetic compressor be performed by qualified experienced personnel only.

**WARNING:** R410A systems operate at 50% - 60% higher pressure than R22. R22 service equipment should not be used with R410A refrigerant. Refer to the attached pressure temperature chart (see page 31 for comparison).

### BEFORE CONDEMNING A SINGLE-PHASE COMPRESSOR THAT FAILS TO START...

1. **Verify all following components are OK:**
  - A. Run capacitor
  - B. Starting components (even if not originally installed, start assist should be tried before going to step 2)
  - C. Contactor
  - D. Winding resistance within manufacturer's specification (**assure compressor is cool to the touch**)
  - E. Compressor not grounded via ohmmeter/Megger, etc.
  - F. Compressor power terminals are tight and secure
  - G. Check for hot spots in system wiring (wire insulation melted, connectors, insulators melted, etc.)
2. **Verify locked rotor pull-down voltage (LRPDV).** Always check **LRPDV** before removing the old or new replacement compressor. If the **LRPDV** reduces the supply voltage to the compressor below the "guaranteed to start" voltage of the compressor (single-phase 230/208 LRPDV is 197v), the power supply must be corrected before removing the compressor.

Procedure to check for **LRPDV**:

**Warning! Make sure system is properly grounded before proceeding!**

- A. Connect a voltmeter to the common terminal and run terminal of the compressor.
  - B. Remove the start wire from the compressor and insulate the connector lead wire.
  - C. Terminal cover and retainer **MUST** be installed before applying voltage. (See warning on page 5.)
  - D. Apply voltage to the compressor and measure the voltage as the compressor attempts to start (during locked rotor). If internal overload trips, allow time for reset before continuing.
  - E. If the voltage at the compressor terminals does not pull down below the **LRPDV**, reconnect the start wire and try to start again. If the compressor does not start, proceed to step 3 below.
3. **Direct wiring.** This wiring eliminates all other components and system wiring.
    - A. Hard-wire from a fused disconnect to the **C** and **R** terminals of the compressor
    - B. Wire in a new run capacitor from the **S** terminal to the **R** terminal **at** the compressor using new wire leads (see page 9 permanent split capacitor-wiring diagram)
    - C. Turn on disconnect, verify LRPDV and measure start winding current (see item 11, page 5)
    - D. If compressor does not start, add a two-wire start assist kit in parallel with the run capacitor and repeat step 3 (C). If the pressures are equalized and the LRPDV and start current are OK, and the compressor still does not start, it is definitely faulty.

**WARNING:** Never use oxygen to pressurize a refrigeration or air conditioning system. Oxygen can explode on contact with oil and could cause personal injury. When using high pressure gas such as nitrogen or CO<sub>2</sub> for this purpose, be sure to use a regulator that can control the pressure down to 1 psig.

## INSTALLATION PROCEDURES AFTER COMPRESSOR HAS BEEN VERIFIED AS FAULTY...

The following instructions are general in nature but include major points of consideration that will ensure proper installation and protect you from possible personal injury. Please use this as a checklist, taking each item in its order before proceeding to the next. If more information is required, please call Bristol Compressors' Service Department.

### VERY IMPORTANT

Do not leave compressor or system open to atmosphere for longer than 15 minutes maximum. The Polyolester lubricants are at least 100 times more hygroscopic (ability to absorb moisture) than mineral oils. It is almost impossible to remove the moisture absorbed by the lubricant even with heat and vacuum.

1. **VERIFY PROPER APPLICATION.**
- A. Verify that the compressor being replaced and the Bristol compressor have a like capacity for the refrigerant being used and that the **voltage** and **frequency** characteristics are the same.
  - B. Verify if the new replacement compressor requires a discharge muffler. **Do not remove the discharge muffler from the system** unless you replace it with the required muffler for the new compressor. See page 13 for muffler information. Consult your wholesaler if you have any questions about proper compressor application.



**WARNING:** To avoid electrical shock, power to the compressor should remain off during performance of Steps 2 through 10.

2. **DETERMINE CAUSE OF INITIAL FAILURE.** In order to prevent a second failure, the cause of the original failure must be determined. Identify the cause and make the necessary repairs.
- A. **BEFORE REMOVING THE FAULTY COMPRESSOR:** Remove refrigerant charge using proper recovery procedures. Call 1-800-235-7882 for the name of the nearest Dupont authorized distributor, or 1-800-631-8138 for Honeywell Chemical Representative or 1-800-725-5532 Mexichem for information on refrigerant reclaim programs.
  - B. Remove the electrical leads from the compressor. Note and label the terminal to which each wire is connected.
  - C. During the next operation, the access ports should be open so that pressure does not build up in the system. Use a high temperature torch to sweat the suction line and the discharge line loose from the compressor.
  - D. Remove the faulty compressor.
  - E. **Assure excessive oil does not remain in the system. Measure oil in the failed compressor and, if oil is low, flush excess from system (or see alternative below).**

Good indicators of excess oil are: violent vibration and/or high **variable** sound as the extra oil moves through the system.

**Alternatives:** If the excess oil cannot be flushed from the system, the last alternative is to reduce the oil charge in the new compressor by the amount left in the system.

- This procedure should be used only if the following are true:
  - The oil remaining in the system is dry (i.e., system had not leaked down)
  - Oil type is same as in the replacement compressor
  - Compressor failure was not a motor burnout
  - The oil remaining in the system is less than 50% of the original oil charge
  - Suction filter drier must be installed
- Procedure if failed compressor has lost more than 50% of the original oil charge
  - Operate new compressor for 15 minutes in cooling mode (30 minutes if a suction line accumulator is installed)
  - Recover refrigerant and remove the compressor
  - Remove oil from the compressor and recharge with fresh oil per the manufacturer's specifications

**CAUTION:** The compressor may contain harmful acids—be sure to handle with extreme care using proper protection equipment. After confirming oil charge level, return oil to compressor and install suction and discharge rotalock caps. Copper tube fittings should be brazed closed. This is needed to prevent further contamination of the compressor and to prevent spillage from the compressor.

3. **MOUNT THE NEW COMPRESSOR.** Do not remove dust cover or rubber shipping plugs until all other connections have been completed (i.e., filters installed and all tubing changes made—see steps 4, 5 and 6). Again, the compressor should not be open to the atmosphere for more than 15 minutes. Be sure to use the new mounting grommets that were shipped with the compressor. If the mounting sleeves shipped with the compressor are used, the mounting bolts will bottom out when tight. Use care not to over-compress the mounting grommets when the mounting sleeves cannot be used.
4. Install the proper discharge muffler if the system does not have one. Refer to Tables 3 and 4 on page 12 to confirm if the replacement compressor requires a discharge muffler and the size required. **H22J and R92J compressors have an internal muffler, therefore, the tables do not apply to these two models.**
5. **INSTALL FILTER DRIERS.** Bristol Compressors recommends the use of new adequately sized liquid and suction line driers anytime a compressor is replaced. If the new compressor is to be used to replace a compressor with a burned motor, the use of a high acid neutralizing filter drier is recommended. **For heat pumps, a suction filter drier must be installed between the accumulator and the compressor suction inlet. In addition, a bi-directional heat pump liquid line drier or factory recommended driers must be installed. NOTE: ALWAYS REMOVE OLD FILTER DRIERS.**
6. **BRAZE ON SUCTION AND DISCHARGE LINES.** Flow an inert gas, such as nitrogen or CO<sub>2</sub>, through the system at approximately 1/4 to 1 psig. This will reduce the possibility of oxidation inside the tubing. Braze on the suction and discharge lines and braze the process tube shut following the recommendation listed below. Note: The process tube has been eliminated on most compressors.

**COPPER TUBING:** If additional copper tubing is required, use only clean, dehydrated refrigeration grade tubing with sealed ends.

**BRAZING ALLOYS:** **CAUTION: Do not use 95/5, 50/50 or 40/60 soft solder for brazing.** Use Sil-Fos or Phos Copper, or similar brazing alloys with high tensile strength on copper welds only. Weld steel to copper only with silver brazing alloys.

**BRAZING PROCEDURE:** To ensure properly brazed joints, Bristol Compressors recommends that the following steps be used:

- a. Exercise extreme care when cutting and forming tubes to keep dirt, filings, and other contaminants from entering the system.
- b. Do not use excessive amounts of brazing alloy as some of the excess may penetrate the joint and enter the system.
- c. If flux must be used, take necessary precautions to ensure that the flux does not enter the system.
- d. Use damp cloths or other heat absorbent material to ensure that the factory-brazed joints on the compressor do not become damaged. If damp cloths are used, take care not to allow moisture to enter the system.
- e. Do not overheat brazed joints as excess heat will cause formation of copper oxide on the inside wall of the tubing. Flow an inert gas through the system, as explained above.

7. **CHECK SYSTEM FOR LEAKS.** After installation is complete, pressurize the system to 75 psig using nitrogen and a few ounces of system refrigerant. Check for leaks using a halide torch, soap bubbles or an electronic halogen leak detector. When all connections test satisfactorily, release pressure using proper recovery procedures, then proceed to next step.

8. **CAUTION:** The compressor may contain harmful acids—be sure to handle with extreme care using proper protection equipment. After confirming oil charge level, return oil to compressor and install suction and discharge rotalock caps. Copper tube fittings should be brazed closed. This is needed to prevent further contamination of the compressor and to prevent spillage from the compressor.
9. **CHECK THE ELECTRICAL SYSTEM.** While the system is evacuating, connect the electrical leads to the compressor terminals. Verify that the electrical system is wired according to the unit's manufacturer and Bristol's wiring diagram on page 9. Verify that the electrical components match those specified on the compressor electrical data sheet on pages 14 through 30. **Start components (start capacitor and relay) are required on all systems that incorporate a hard shut-off or non-bleed thermostatic expansion valve.** It is a normal practice to replace all starting components any time a compressor is changed. Check all connections and terminals to be sure they are tight. Connect the crankcase heater (standard on all "A" Series). **Power to the crankcase heater must be energized continuously.** Voltage to an insertion type heater can be anything between 187 to 600 volts. **If supplied, the insertion heaters are identified by their black or red leads coming from a well at the bottom of the compressor.** Operational voltage for wrap-around type heaters must be verified.

**WARNING:** Application of voltage to the compressor with the terminal cover and retainer removed can result in serious personal injury or death.

10. **CHARGE THE SYSTEM.** When a vacuum of at least 200 microns is reached, close gauge valve, remove vacuum pump, and break the vacuum by charging the system through the liquid line—**not the discharge line.** To assure the proper refrigerant composition is charged in the system with non azeotrope refrigerants, it is important that liquid only be removed from the charging cylinder. Never dump liquid refrigerant into the compressor. Since some compressors may be damaged if liquid refrigerant enters the suction side of the compressor, it is important to charge the refrigerant slowly into the suction line to allow it to vaporize before it enters the compressor. A throttling valve can be used to ensure that the liquid is converted to vapor prior to entering the system.

Charge the system according to the manufacturer's specifications. Be sure to compensate the charge for the addition of the filter drier. Consult unit pressure/superheat chart on the unit door panel for the correct superheat since pressures and superheat change with the ambient temperature.

**WEIGHING in the system charge to the factory specification will help point out system faults that may still exist.**

11. **START-UP. CLAMP-ON AMMETER MUST BE IN PLACE BEFORE POWER IS APPLIED TO MONITOR START WINDING CURRENT ON START-UP!!** See page 6.
12. **Most of today's high efficiency compressors will actually start and run on the start winding if line voltage is applied to the start winding instead of the run winding (i.e., the start and run wire are reversed—see schematic on page 6). For this reason, the voltage must be checked on the common and run terminal of the compressor to confirm the line voltage is being applied to the proper terminals. If the voltage on the common and run terminals is higher than the line voltage supplied to the system—*check system for proper wiring.***

**ASSURE THESE NORMAL START WINDING CURRENTS ON START-UP**

<u>CONFIGURATION</u>	<u>APPROXIMATE CURRENT</u>
NORMAL START WITH RUN CAP ONLY	2 - 10 AMPS
NORMAL START WITH RUN AND START CAP	20 AMPS AND DROP TO 2-10 AFTER START
NORMAL START WITH START CAP (INDUCTION RUN)	20 AMPS AND DROP TO 0 AFTER START

**WARNING:** If above currents are exceeded for more than 5 seconds, disconnect power and correct the fault before restarting.

**NOTE: Assure voltage to compressor does not drop below minimum allowable voltage (eg. 197 volts for 230/208-1-60) during the period the compressor is trying to start. Refer to page 2 for explanation of test to check LOCKED ROTOR PULL-DOWN VOLTAGE.**

**FOR CAPACITOR START/CAPACITOR RUN (CSCR) MODELS**

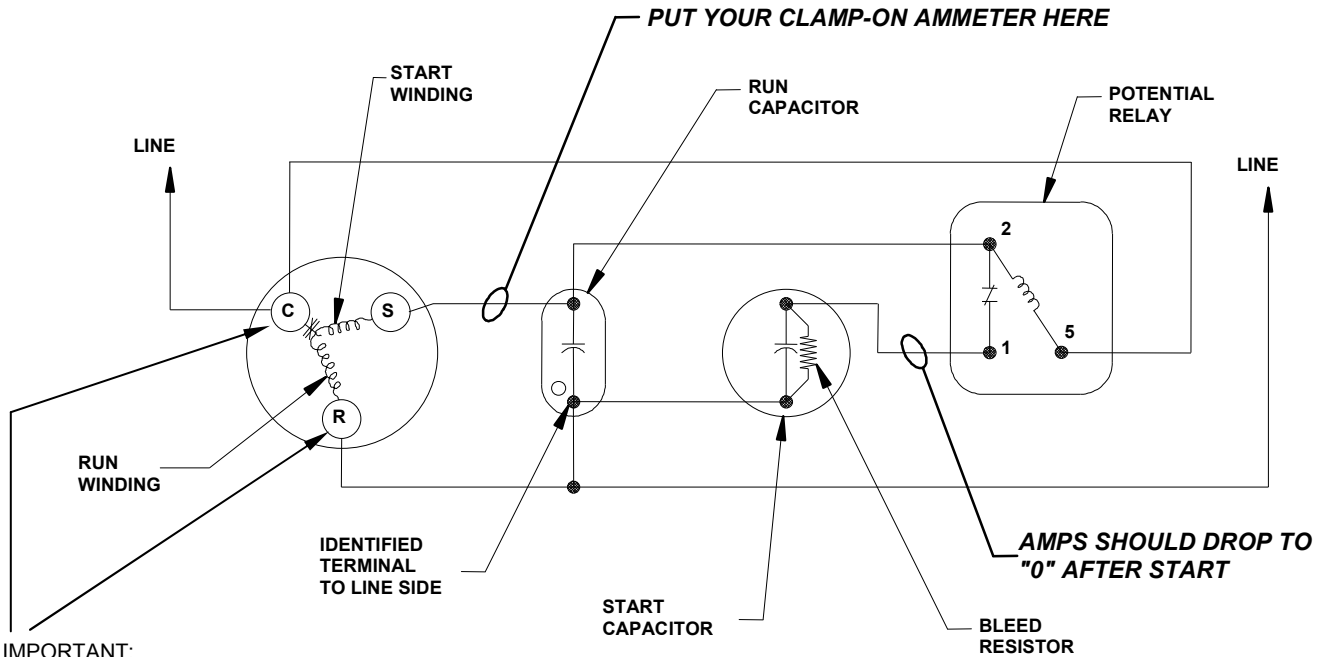

**IMPORTANT:**  
Confirm line voltage to compressor terminals C and R.

Caution: Terminal cover must be in place when voltage is being applied.

**FOR CAPACITOR START INDUCTION RUN (CSIR) MODELS**

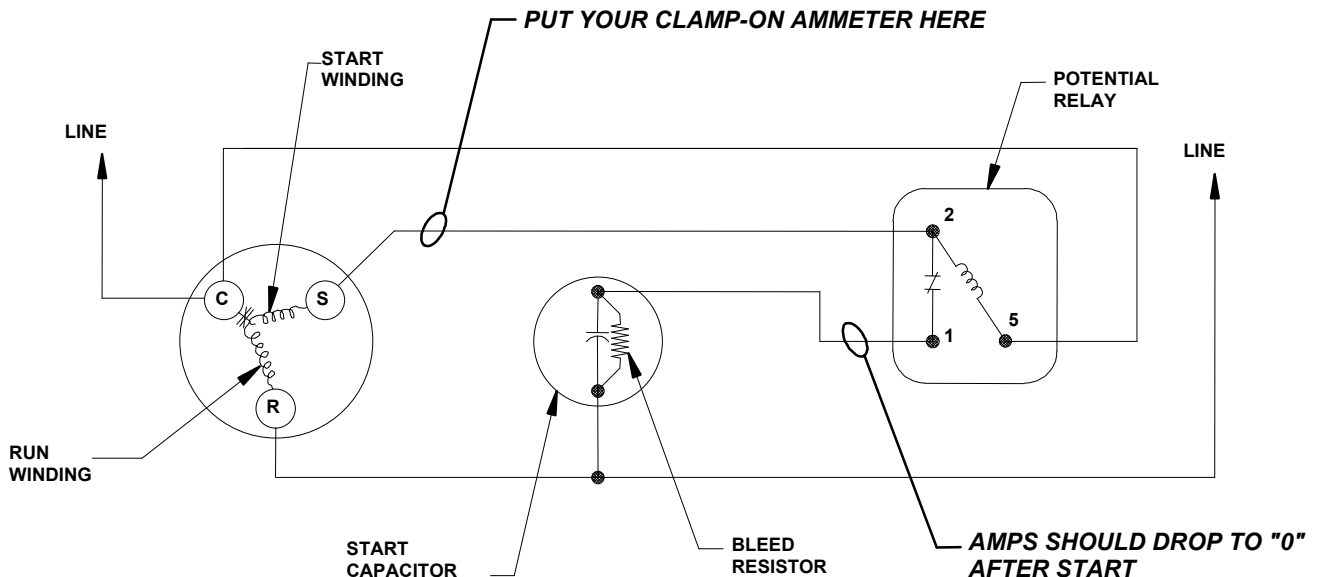

13. **VERIFY SYSTEM WILL NOT ALLOW LIQUID FLOODBACK.**

HEAT PUMP

- STEP 1: Operate system in the heating mode with outdoor fan disconnected.
- STEP 2: Run system until the designed winter condition in your area is reached (may need to cover coil for this test).
- STEP 3: Check suction superheat 6" from compressor inlet.
- STEP 4: Superheat should not drop below 5°F (3°K) (prefer no lower than 10°F [6°K]).
- STEP 5: Sump temperature should always be 50°F (28°C) or higher above saturated suction temperature.

**EXAMPLE: "R-22"**

$$\begin{aligned} 38 \text{ psig} &= 16^\circ\text{F} (-9^\circ\text{C}) &&= \text{SATURATED SUCTION} \\ &+ 50^\circ\text{F} (28^\circ\text{K}) &&= \text{MINIMUM TEMP. DIFFERENCE} \\ &66^\circ\text{F} (19^\circ\text{C}) &&= \text{MINIMUM SUMP TEMPERATURE} \end{aligned}$$

**EXAMPLE: "R410A"**

$$\begin{aligned} 72 \text{ psig} &= 16^\circ\text{F} (-9^\circ\text{C}) &&= \text{SATURATED SUCTION} \\ &+ 50^\circ\text{F} (28^\circ\text{K}) &&= \text{MINIMUM TEMP. DIFFERENCE} \\ &66^\circ\text{F} (19^\circ\text{C}) &&= \text{MINIMUM SUMP TEMPERATURE} \end{aligned}$$

COOLING MODE (HEAT PUMP)

- STEP 1: Operate system in cooling mode with indoor fan disconnected and repeat steps 3, 4 and 5.

AIR-CONDITIONING/REFRIGERATION UNITS

- STEP 1: Operate system in the cooling mode with indoor fan disconnected and repeat steps 3, 4 and 5.

**CHECKING RETURN GAS SUPERHEAT – R-22 SYSTEM**

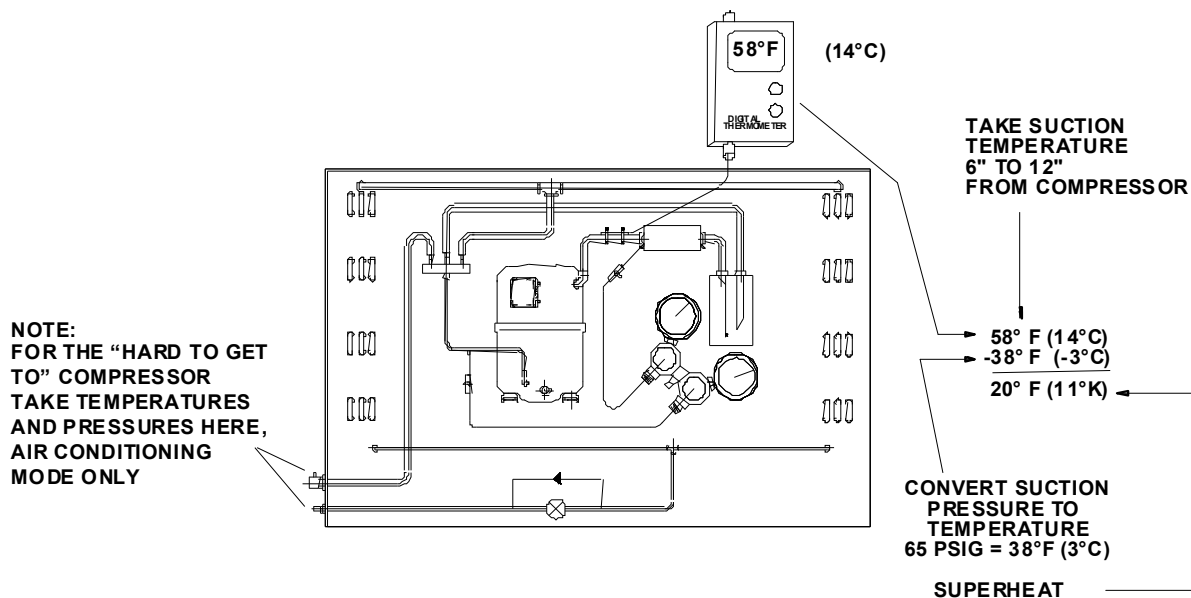

14. **CHECK FILTER DRIERS FOR CONTAMINATION.**

- A. **Suction Line Filter:** If internal contamination is heavy, the suction line filter drier may become clogged and ineffective. Check the pressure drop across the filter drier after approximately 8 hours running time and, if it exceeds 2 psig, replace.
- B. **Liquid Line Filter:** Always replace the original equipment liquid line filter drier(s). If the OEM liquid line drier(s) is not removed from the system, a restriction most likely will result. A slight restriction in this filter will reduce the efficiency of the system. A large restriction will cause the suction pressure and discharge pressure to be reduced. This reduction in pressure will occur only with a properly charged system (i.e., refrigerant weighed in to the OEM specifications). An over-charged system will increase pressures when there is a restriction in the liquid line. The service person tends to add more charge to the system to increase the suction pressure. Normally, any charge added above the OEM specifications will increase the suction pressure due to the discharge pressure increasing but in the case of a restriction, charge can be added to a point the system shuts down on the high pressure limit switch. The service person may not see the higher discharge pressure due to his service port being in the liquid line which is normally downstream from the liquid line filter drier in residential split systems. A pressure port installed in the hot gas discharge line just as it exits the compressor is required to see true discharge pressure.
- C. **Discharge Line Filter:** Some OEM equipment may have a filter in the hot gas line (6" – 12" from compressor). Checks outlined in (B) above apply.

**IMPORTANT:** The compressor has an internal relief valve (IPRV) that is designed to open if the system is subjected to a high pressure situation. Example causes are: overcharged, air in system, restriction, factory-installed metering device screens not removed and cleaned, old liquid line filter left in the system, poor airflow across the condenser, condenser fan failure, poor airflow across the evaporator in the heating mode (dirty return air filter(s)), poor system design (duct system undersized), etc. The IPRV will open when the discharge pressure exceeds the suction pressure by more than 450 psig ("B" and "J" products) or 400 psig ("A" products) with R-22 refrigerant and increases to 550 psig for all R410A products. If the relief valve opens, a high velocity gas flow may be heard inside the compressor housing. In some cases, the relief valve may open quickly due to a restriction in the system. If this occurs, the high pressure may be difficult to observe on standard gauges. In these instances, installation of a discharge service gauge on the discharge line just as it exits the compressor, the development of high pressure can be observed before the relief valve opens. Installing the discharge service gauge on the liquid line outside the system may not detect a restriction. To reset the relief valve, shut the compressor off for at least 5 minutes, allowing pressures to equalize.

**REVIEW ALL FOURTEEN STEPS TO MAKE SURE NOTHING WAS OVERLOOKED.**

# SINGLE PHASE WIRING DIAGRAMS

## START ASSIST—CAPACITOR START/CAPACITOR RUN (CSCR)

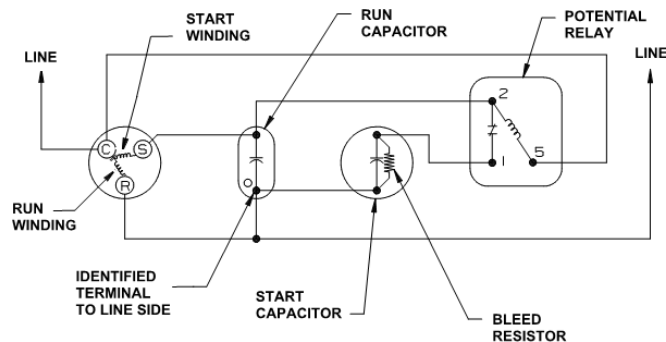

Use this diagram on systems with expansion valve and systems that do not allow pressure equalization prior to compressor start.

**NOTE:** WHEN CRANKCASE HEATER IS USED, CONNECT TO INCOMING POWER LINE SO THAT HEATER IS ENERGIZED CONTINUOUSLY.

## PERMANENT SPLIT CAPACITOR (PSC)

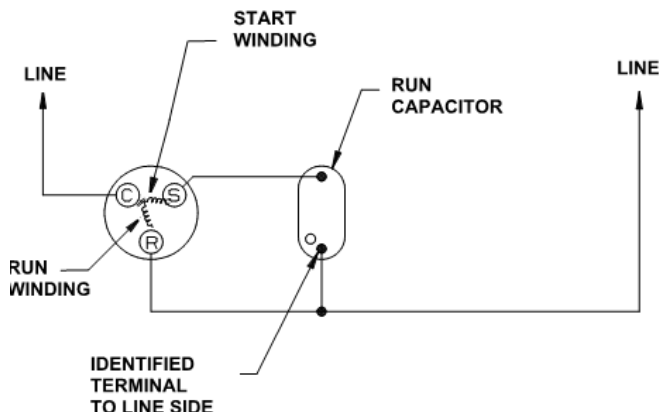

Use this diagram on systems that allow pressure equalization prior to compressor start.

**NOTE:** WHEN CRANKCASE HEATER IS USED, CONNECT TO INCOMING POWER LINE SO THAT HEATER IS ENERGIZED CONTINUOUSLY.

## START ASSIST (PTCR AND RUN CAPACITOR)

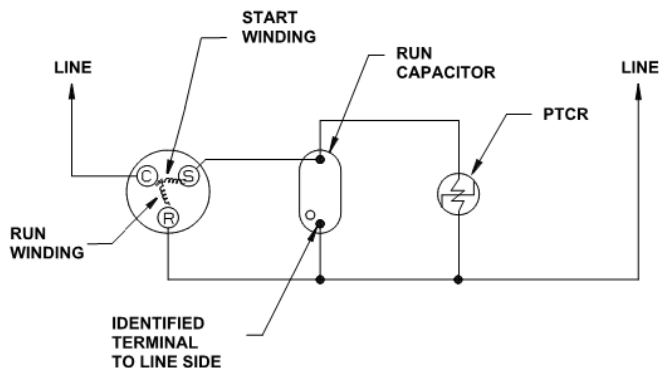

Use this light start assist in case of a slight low voltage condition with equalized pressures prior to compressor start.

**NOTE:** SOFT START ASSIST (PTCR) IS REQUIRED ON SOME HIGH EFFICIENCY COMPRESSORS (SEE PAGES 17 AND 18) EVEN WHEN THE SYSTEM EQUALIZES. "C" IN THE 8TH DIGIT OF MODEL NUMBER IDENTIFIED COMPRESSORS THAT REQUIRE PTCR START ASSIST. NOT REQUIRED WHEN A START ASSIST KIT IS USED (RELAY START CAPACITOR).

## DUAL CAPACITOR WIRING SCHEMATIC

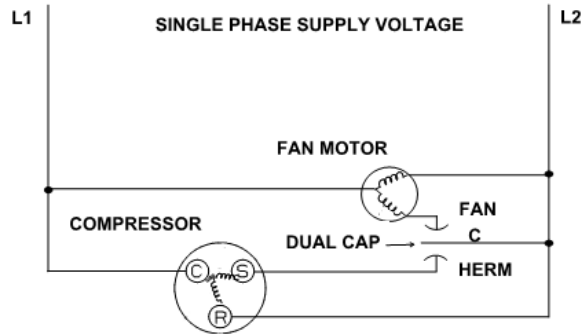

### Starting Characteristics

The “BENCHMARK” H2\*J models do not require start components on systems where the pressure equalizes completely in the off-cycle. For single-phase applications, a low torque PTCR can be used if only a light assist is needed, as in the case of a low voltage condition. If a non-bleed expansion valve is used, or other reasons exist that will not allow pressure equalization prior to compressor start-up, then a start capacitor and potential relay are required. (**Exception:** See Start Component Eliminations below for an option to eliminate starting components.) High torque start components are available for the “BENCHMARK” model. The PTCR and starting components are listed under the Electrical Accessory Components section of the individual compressor specification sheet. This information can be obtained via Bristol’s web site [www.bristolcompressors.com](http://www.bristolcompressors.com) or directly from Bristol Compressors.

Recommended sources for the electrical components are:

Source for the PTCR 305 Series

Vishay Americas  
One Greenwich Place  
Shelton, CT 06494  
Phone: (402) 563-6866  
Web: [www.business-americas@vishay.com](mailto:www.business-americas@vishay.com)

Source for the Electrica Relays

Manitowoc Relay & Protectors, Inc.  
1429B Wentker Court  
P.O. Box 146  
Two Rivers, WI 54241-0146  
Phone: (920) 553-1440  
Web: [afond@lakefield.net](mailto:afond@lakefield.net)

### Start Component Elimination

An innovative starting concept has been developed by Bristol Compressors that eliminates the compressor start components (start capacitor/relay) required for systems using non-bleed type expansion valves. This optional feature is available on select “BENCHMARK” models. They are identified by the letter “B” in the **seventh character** of the model number (H2\*J\*\*B). These “Bleed” compressors are designed to internally equalize by utilizing an external check valve in conjunction with a non-bleed type TXV. Bristol recommends the check valve to be installed on the compressor’s discharge connector tube (or as close as possible) in order to minimize pressure equalization time across the compressor valves.

It is recommended that each OEM perform start tests at their worst case condition to assure no issues with their placement of the check valve. It is also important to determine if the equalization time is acceptable with the check valve moved downstream of the compressor discharge connector. This technique will help maintain system operating pressures during the off-cycle, thus improving the SEER performance by decreasing  $C_D$ . The internal equalization is transparent to the customer and requires no special attention.

### Bleed Compressors with Oval Housing

**Only** an external check valve is required **since these models employ an internal discharge muffler. (Exception: 50 Hz operation requires external muffler).** Again, the check valve may be installed at any point in the hot gas line, preferably as close to the compressor discharge connector as possible. See Table 2 for recommended check valves. Refer to Table 3, page 12, for external muffler requirements for 50 Hz operation only.

**TABLE 2  
CHECK VALVES FOR BLEED COMPRESSORS**

Bristol Part Number	Manufacturer	Material	Manufacturer's Part Number	Muffler Diameter (inch/cm)	Length (inch/cm)	Inlet/Outlet ID or OD (inch/cm)	Internal Free Volume (inches <sup>3</sup> /cc)
NA	Mueller Refrigeration	Copper	A-17936	1.125 / 2.85	5.23 / 13.28	Inlet/Outlet: .50 / 1.3 ID	2.5 / 41
250554	Henry Technologies	Copper	MS-887	1.125 / 2.85	3.75 / 9.52	Inlet: .50 / 1.3 ID Outlet: .50 / 1.3 OD	1.5 / 24
NA	Henry Technologies	Copper	MS-8	1.25 / 2.85	3.75 / 9.52	Inlet/Out: .50 / 1.3 ID	1.5 / 24

**Bleed Compressors with Round Housing**

These models **do not** employ an internal discharge muffler; therefore they require one of the following options:

- 1) **An external discharge muffler with integral check valve.** See External Discharge Muffler Requirement—Round Housing. See Table 4 for a listing of these mufflers with integral check valves which integrate the individual components into one compact assembly thus reducing the number of braze joints. Properly installed, this method is effective for reliable starting without a start capacitor/relay at all expected differentials. The required time for internal compressor equalization depends on the specific pressure differential when the compressor cycles off. To assure pressure equalization, Bristol Compressors recommends a minimum of five minute anti-short-cycle delay. However, if muffler with integral check valve combinations with larger volumes than noted in Table 4 are employed, a longer time delay may be needed to assure equalized pressure at start up.
- 2) **A check valve** installed as close to the compressor discharge connector as possible, along **with a separate discharge muffler** installed downstream (see Table 3 for muffler; must be installed as illustrated in Section 9).

**System designers must perform system evaluations to assure the pressures are equalized across the compressor before each compressor start-up and to set their time delay accordingly.**

**H22J AND R92J MODEL CCOMPRESSORS HAVE AN INTERNAL MUFFLER  
TABLES 3 AND 4 DO NOT APPLY TO THESE MODELS**

**PRODUCT GUIDE FOR TABLE 3**

Application	Cooling Only				Heat Pumps			
	60 Hz		50 Hz		60 Hz		50 Hz	
Voltage Frequency	Muffler*	Tube Length* Dim - "A"	Muffler*	Tube Length* Dim - "A"	Muffler*	Tube Length* Dim - "A"	Muffler*	Tube Length* Dim - "A"
<b>Round Compressor Housing</b>	A	13" ± 2"	B	20" ± 2"	B C (optional)	13" ± 2"	B C (optional)	20" ± 2"
<b>Oval Compressor Housing</b>	External Muffler Not Required		External Muffler Not Required		External Muffler Not Required		External Muffler Not Required	

Note: Use above Product Guide Letter designation in choosing muffler in Table 3 below.

\*See page 14 for further details on muffler and tube length.

**TABLE 3**

**EXTERNAL MUFFLER ONLY**

Product Guide Letter	Bristol Part Number	Manufacturer	Material	Manufacturer Part Number	Muffler OD (inch/cm)	Length (inch/cm)	Inlet and Outlet ID (inch/cm)	Internal Free Volume (inches <sup>3</sup> /cc)
A	302140	Parker	Copper	031780-00	1.6 / 4.1	4.4 / 11.1	.50 / 1.3	5.4 / 88.5
A	302164	Kraftube	Steel	EM-20-2.605-000	2.1 / 5.4	4.9 / 12.4	.50 / 1.3	9.9 / 162.2
B	302146	Parker	Copper	058750-00	2.0 / 5.1	6.5 / 16.5	.50 / 1.3	13.3 / 218.0
B	302165	Kraftube	Steel	EM-20-4.725-00-0	2.1 / 5.4	7.0 / 17.8	.50 / 1.3	15.8 / 258.9
C	302169	Sporlan	Steel	M-16E32	3.0 / 7.6	6.0 / 15.0	.50 / 1.3	24 / 393.0
C	302167	Kraftube	Steel	EM-30-4.250-00-0	3.1 / 7.9	6.5 / 16.5	.50 / 1.3	35 / 573.5

**TABLE 4**

**EXTERNAL MUFFLER WITH INTEGRAL CHECK VALVE  
(for use only with round housing compressors with bleed)**

Bristol Part Number	Manufacturer	Material	Manufacturer Part Number	Muffler OD (inch/cm)	Length (inch/cm)	Inlet and Outlet ID (inch/cm)	Internal Free Volume (inches <sup>3</sup> /cc)
250577	Superior	Copper	900RGN-8S	1.63 / 4.14	7.88 / 20.0	.50 / 1.3	9.7 / 159
250578	Mueller	Copper	A-18051	1.63 / 4.14	7.88 / 20.0	.50 / 1.3	9.6 / 157
250576	Henry Technologies	Copper	MSM-11	1.63 / 4.14	7.88 / 20.0	.50 / 1.3	9.9 / 162

## External Discharge Muffler Requirement - Round Housing

**NOTE:** 60 Hz oval housing models do not require an external discharge muffler.

**NOTE:** Use of only an external discharge muffler (i.e., no check valve) applies only to models that do not have a “B” in the seventh character of the model number.

Bristol Compressors’ research has proven that the use of an external discharge muffler is far superior to the internal style. This is due to the space limitation and “fixed” location within the hermetic shell. The external muffler approach gives the system designer the opportunity to utilize the most effective muffler type and location. The round housing “BENCHMARK” models do not employ an internal discharge muffler and require that an external muffler be precisely placed in the discharge line as illustrated in Figure 1. For 60 Hz applications, install assembly with **13 inches** ( $\pm 2$  in.) or 33 cm ( $\pm 5.1$  cm) of tubing between the discharge tube outlet and the muffler. For 50 Hz applications, install assembly with **20 inches** ( $\pm 2$  inches) or 50.8 cm ( $\pm 5$  cm) of tubing between the discharge tube outlet and the muffler (refer to dimension “A” in Figure 1 of tubing placement). The muffler must be UL/CSA certified for use as a high-side component for the intended refrigerant application.

### IMPORTANT NOTES:

- 1) It is preferable that the muffler be installed as shown in Figure 1 with use of the mufflers shown in Table 3. However, **if it is necessary that bends be placed in the tube between the compressor and the muffler, both indoor and outdoor sound evaluations must be performed to confirm acceptance of the final configuration. Bristol field testing indicates any bends prior to the muffler can result in increased sound and tubing vibration, primarily with copper mufflers.**
- 2) If the Sporlan muffler Part No. M-16E32 (see Table 3) is used, the DIM “A” tube may be reduced to a minimum length of 9 inches. No bends would be allowed in the tube between the compressor and the muffler.
- 3) The tubing design between the compressor and the condensing unit coil is very important in regard to both sound performance and reliability. The length, number of bends, geometry, and method of attachment can have a significant impact on acoustic performance of the muffler and tube vibration levels. **The system tubing vibration should be thoroughly evaluated using accelerometers.** Discharge tube total displacement (peak-to-peak) needs to be kept below 0.011 inches (as measured 3.5 inches from the top of the compressor discharge elbow) to avoid premature tubing failure due to excessive vibration.

**The Table 3 generic muffler recommendations are based on Bristol sound test evaluations with various systems. The Sporlan M-16E32 yielded the best overall field results.** Operational characteristics can vary between different system types and applications. The OEM system designer must perform sound tests to determine the best muffler configuration and optimize its location in the discharge line to satisfy their particular design requirements. All available options should be thoroughly evaluated and the following considered:

- **A heat sink is required to prevent internal check valve damage during brazing**
- **Do not use ball type check valve**
- A filter-drier in the discharge line may be substituted for the external muffler, if system testing confirms that the filter-drier provides acceptable discharge pulse and sound attenuation.
- **If components other than those recommended in Tables 2, 3 and 4 are utilized,** Bristol advises the use of a high quality, non-positional check valve designed for near-zero leak rates. The muffler and check valve must be UL/CSA certified for use as high side components for the intended refrigerant application.
- Increased internal free volume or multi-chamber style discharge mufflers may provide superior results.

If you have a compressor that is not listed on pages 14 through 30, contact your Wholesaler or Distributor for installation procedures and electrical components.

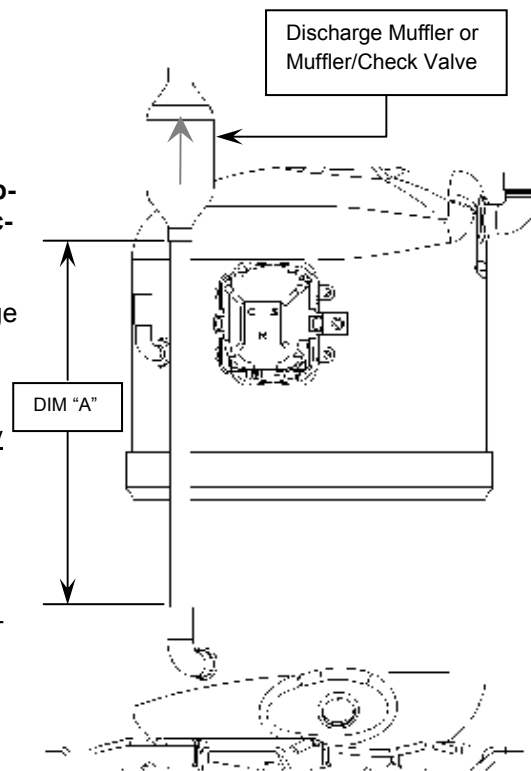
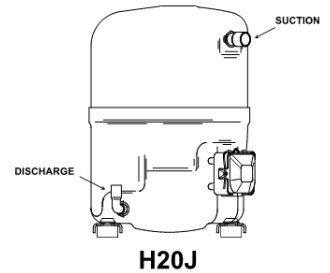

FIGURE 1

# REFRIGERATION/AIR CONDITIONING AND HEAT PUMP ELECTRICAL COMPONENTS PARTS FOR SINGLE PHASE COMPRESSORS

## H20J SERIES 60 Hz

Compressor Model Number	Voltage Phase Hz.	Capacitors		Potential Relays			
		Run $\mu$ fd/Volts	Start $\mu$ fd/Volts	GE 3ARR3	Mars		PTCR Starter
					6-Pak	OEM	
H20J153ABC	230/208-1-60	30/370	145-175/250	3V	66	16048	Optional
H20J173ABC	230/208-1-60	30/370	145-175/250	3V	66	16048	Optional
H20J193ABC	230/208-1-60	30/370	145-175/250	3V	64	16048	Optional
H20J213ABC	230/208-1-60	30/370	145-175/250	3U	66	16049	Optional
H20J253ABC	230/208-1-60	35/370	145-175/250	3N	65	16082	Optional
H20J273ABC	230/208-1-60	30/440	189-227/250	10U	71	19005	Optional
H20J293ABC	230/208-1-60	35/440	189-227/250	10U	71	19005	Optional
H20J303ABC	230/208-1-60	40/370	189-227/250	3L	65	16083	Optional
H20J313ABC	230/208-1-60	40/370	189-227/250	3S	69	16055	Optional
H20J323ABC	230/208-1-60	40/370	189-227/250	3S	69	16055	Optional
H20J353ABC	230/208-1-60	45/370	189-227/250	3S	69	16055	Optional
H20J383ABC	230/208-1-60	45/370	189-227/250	3S	69	16055	Optional
H20J403ABC	230/208-1-60	50/370	216-259/330	3S	69	16055	Optional
H20J423ABC	230/208-1-60	65/370	216-259/330	2S	69	16055	Optional
H20J433ABC	230/208-1-60	65/370	216-259/330	2S	69	16055	Optional
H20J443ABC	230/208-1-60	65/370	216-259/330	2S	69	16055	Optional



NOTE:  
Eleventh character of the model number represents the foot configuration—could be A or B.

## H21J SERIES 60 Hz

Compressor Model Number	Voltage Phase Hz.	Capacitors		Potential Relays			
		Run $\mu$ fd/Volts	Start $\mu$ fd/Volts	GE 3ARR3	Mars		PTCR Starter
					6-Pak	OEM	
H21J143ABC	230/208-1-60	35/370	145-175/250	3P	65	16050	Optional
H21J14BABC	230/208-1-60	35/370	145-175/250	3P	65	16050	Optional
H21J153ABC	230/208-1-60	35/370	145-175/250	3P	65	16050	Optional
H21J15BABC	230/208-1-60	35/370	145-175/250	3P	65	16050	Optional
H21J173ABC	230/208-1-60	35/370	145-175/250	3T	69	16068	Optional
H21J17BABC	230/208-1-60	35/370	145-175/250	3T	69	16068	Optional
H21J193ABC	230/208-1-60	35/370	145-175/250	3T	69	16068	Optional
H21J19BABC	230/208-1-60	35/370	145-175/250	3T	69	16069	Optional
H21J203ABC	230/208-1-60	35/370	145-175/250	3N	65	16082	Optional
H21J20BABC	230/208-1-60	35/370	145-175/250	3N	65	16082	Optional
H21J223ABC	230/208-1-60	30/370	145-175/250	3N	65	16082	Optional
H21J243ABC	230/208-1-60	30/370	145-175/250	3S	69	16072	Optional
H21J24BABC	230/208-1-60	30/370	145-175/250	3S	69	16072	Optional
H21J253ABC	230/208-1-60	30/370	145-175/250	3S	69	16072	Optional
H21J25BABC	230/208-1-60	30/370	145-175/250	3S	69	16072	Optional
H21J273ABC	230/208-1-60	40/370	189-227/330	3S	69	16072	Optional
H21J27BABC	230/208-1-60	40/370	189-227/330	3S	69	16072	Optional
H21J293ABC	230/208-1-60	40/370	189-227/330	3S	69	16072	Optional
H21J29BABC	230/208-1-60	40/370	189-227/330	3S	69	16072	Optional
H21J303ABC	230/208-1-60	40/370	189-227/330	3S	69	16072	Optional
H21J30BABC	230/208-1-60	40/370	189-227/330	3S	69	16072	Optional
H21J323ABC	230/208-1-60	40/370	189-227/330	3S	69	16072	Optional
H21J32BABC	230/208-1-60	40/370	189-227/330	3S	69	16072	Optional
H21J343ABC	230/208-1-60	45/370	189-227/330	3S	69	16072	Optional
H21J34BABC	230/208-1-60	45/370	189-227/330	3S	69	16072	Optional
H21J363ABC	230/208-1-60	45/370	189-227/330	3S	69	16072	Optional
H21J36BABC	230/208-1-60	45/370	189-227/330	3S	69	16072	Optional
H21J383ABC	230/208-1-60	45/370	189-227/330	3S	69	16072	Optional
H21J38BABC	230/208-1-60	45/370	189-227/330	3S	69	16072	Optional
H21J403ABC	230/208-1-60	45/370	189-227/330	3S	69	16072	Optional
H21J40BABC	230/208-1-60	45/370	189-227/330	3S	69	16072	Optional
H21J433ABC	230/208-1-60	65/370	216-259/330	3S	69	16072	Optional
H21J43BABC	230/208-1-60	65/370	216-259/330	3S	69	16072	Optional
H21J443ABC	230/208-1-60	65/370	216-259/330	3S	69	16072	Optional
H21J44BABC	230/208-1-60	65/370	216-259/330	3S	69	16072	Optional

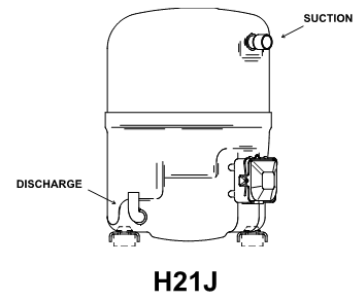

**H22A SERIES 60 Hz**

Compressor Model Number	Voltage Phase Hz	Capacitors		Potential Relays			PTCR Starter
		Run $\mu$ f/Volts	Start $\mu$ f/Volts	GE 3ARR3	Mars		
					6-Pak	OEM	
H22A503ABC	230/208-1-60	40/440	135-155/330	4A	64	16047	Optional
H22A543ABC	230/208-1-60	40/440	135-155/330	4A	64	16047	Optional
H22A583ABC	230/208-1-60	40/440	135-155/330	4A	64	16047	Optional
H22A623ABC	230/208-1-60	40/440	135-155/330	4A	64	16047	Optional

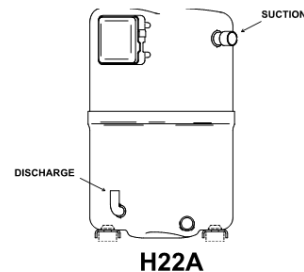

**H22A**

**H22J SERIES 50 Hz**

Compressor Model Number	Voltage Phase Hz	Capacitors		Potential Relays			PTCR Starter
		Run $\mu$ f/Volts	Start $\mu$ f/Volts	GE 3ARR3	Mars		
					6-Pak	OEM	
H22J18BABH	220/240-1-50	30/370	145-175/250	10S			Optional
H22J20BABH	220/240-1-50	35/370	145-175/250	10S			Optional
H22J22BABH	220/240-1-50	35/370	145-175/250	10U			Optional
H22J25BABH	220/240-1-50	40/370	145-175/250	10S			Optional
H22J28BABH	220/240-1-50	40/370	145-175/250	3L			Optional
H22J33BABH	220/240-1-50	40/370	145-175/250	10S			Optional
H22J36BABH	220/240-1-50	45/370	145-175/250	10S			Optional

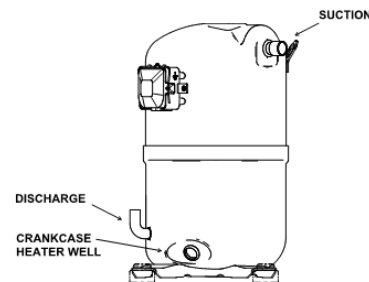

**H22J**

**H22J SERIES 60 Hz**

Compressor Model Number	Voltage Phase Hz	Capacitors		Potential Relays			PTCR Starter
		Run $\mu$ f/Volts	Start $\mu$ f/Volts	GE 3ARR3	Mars		
					6-Pak	OEM	
H22J13BABC	230/208-1-60	30/370	161-191/250	3V	66	16048	Optional
H22J15BABC	230/208-1-60	30/370	161-191/250	3V	66	16048	Optional
H22J18BABC	230/208-1-60	30/370	161-191/250	3V	66	16048	Optional
H22J18BABH	265-1-60	25/240	88-108/330	10S	69	16067	Optional
H22J20BABC	230/208-1-60	30/370	145-175/250	3U	66	16049	Optional
H22J22BABC	230/208-1-60	30/370	145-175/250	3U	69	16049	Optional
H22J22BABH	265-1-60	30/440	88-108/250	10S	69	16067	Optional
H22J25BABC	230/208-1-60	35/370	145-175/250	3T	69	16049	Optional
H22J25BABH	265-1-60	30/440	88-108/330	10S	69	16067	Optional
H22J28BABH	265-1-60	30/440	88-108/250	3L	65	16083	Optional
H22J29BABC	230/208-1-60	35/370	161-191/250	3T	69	16068	Optional
H22J33BABC	230/208-1-60	40/370	145-175/250	3P	65	16050	Optional
H22J33BABH	265-1-60	30/440	88-108/330	10S	69	16067	Optional
H22J36BABC	230/208-1-60	45/370	145-175/250	3N	65	16050	Optional
H22J36BABH	265-1-60	35/440	88-108/330	10S	69	16067	Optional
H22J38BABC	230/208-1-60	45/370	216-259/300	3S	69	16072	Optional
H22J41BABC	230/208-1-60	50/370	216-259/330	3S	69	16072	Optional
H22J44BABC	230/208-1-60	65/370	216-259/330	3S	69	16072	Optional
H22J50BABC	230/208-1-60	40/440	133-155/330	4A	64	16047	Optional
H22J543ABC	230/208-1-60	45/440	133-155/330	4A	64	16047	Optional
H22J583ABC	230/208-1-60	55/440	133-155/330	4A	64	16047	Optional
H22J623ABC	230/208-1-60	55/440	133-155/330	4A	64	16047	Optional

**H23A SERIES 50 Hz**

Compressor Model Number	Voltage Phase Hz.	Capacitors		Potential Relays			
		Run $\mu$ fd/Volts	Start $\mu$ fd/Volts	GE 3ARR3	Mars		PTCR Starter
					6-Pak	OEM	
H23A263ABH	220/240-1-50	35/370	145-175/250	10AS	NA	NA	Optional
H23A283ABK	220/240-1-50	35/370	145-175/250	10AS	NA	NA	Optional
H23A303ABH	220/240-1-50	35/370	145-175/250	10AS	NA	NA	Optional
H23A323ABH	220/240-1-50	40/370	145-175/250	10AT	NA	NA	Optional
H23A353ABH	220/240-1-50	35/370	145-175/250	25AV	NA	NA	Optional
H23A35QABK	220/240-1-50	35/370	145-175/250	25AV	NA	NA	Optional
H23A383ABK	220/240-1-50	35/440	145-175/330	4AA	NA	NA	Optional
H23A38QABK	220/240-1-50	35/370	145-175/250	4AA	NA	NA	Optional
H23A423ABK	220/240-1-50	35/440	145-175/330	27AA	NA	NA	Optional
H23A42QABK	220/240-1-50	40/440	145-175/250	27AA	NA	NA	Optional
H23A463ABK	220/240-1-50	40/440	145-175/330	4AA	NA	NA	Optional
H23A46QABK	220/240-1-50	40/440	135-155/330	4AA	NA	NA	Optional

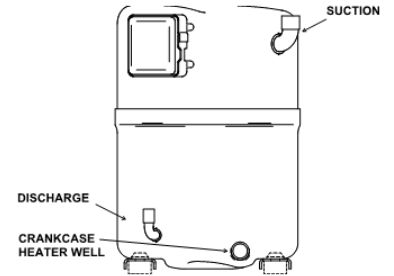

**H23A**

**H23A SERIES 60 Hz**

Compressor Model Number	Voltage Phase Hz.	Capacitors		Potential Relays			
		Run $\mu$ fd/Volts	Start $\mu$ fd/Volts	GE 3ARR3	Mars		PTCR Starter
					6-Pak	OEM	
H23A353ABC	230/208-1-60	35/440	145-175/250	4A	64	16047	Optional
H23A383ABC	230/208-1-60	35/440	145-175/250	4A	64	16047	Optional
H23A423ABC	230/208-1-60	40/440	145-175/250	4A	64	16047	Optional
H23A463ABC	230/208-1-60	40/440	135-155/330	4A	64	16047	Optional
H23A503ABC	230/208-1-60	40/440	135-155/330	4A	64	16047	Optional
H23A543ABC	230/208-1-60	45/440	135-155/330	4A	64	16047	Optional
H23A563ABC	230/208-1-60	55/440	135-155/330	6U	66	16062	Optional
H23A623ABC	230/208-1-60	55/440	135-155/330	4A	64	16047	Optional

**H23B SERIES 50 Hz (Continued on Next Page)**

Compressor Model Number	Voltage Phase Hz.	Capacitors		Potential Relays			
		Run $\mu$ fd/Volts	Start $\mu$ fd/Volts	GE 3ARR3	Mars		PTCR Starter
					6-Pak	OEM	
H23B153ABH	220/240-1-50	25/370	88-108/250	10AS	NA	NA	Optional
H23B15QABH	220/240-1-50	20/370	88-108/250	10AS	NA	NA	Optional
H23B173ABH	220/240-1-50	25/370	88-108/250	10AS	NA	NA	Optional
H23B17QABH	220/240-1-50	25/370	88-108/250	10AS	NA	NA	Optional
H23B17SABH	220/240-1-50	30/370	145-175/250	10AS	NA	NA	Optional
H23B18SABH	220/240-1-50	30/370	145-175/250	10S	69	16067	Optional
H23B193ABK	220/240-1-50	30/370	88-108/250	10AS	NA	NA	Optional
H23B19QABK	220/240-1-50	30/370	88-108/250	10AS	NA	NA	Optional
H23B203ABK	220/240-1-50	30/370	88-108/250	25AS	NA	NA	Optional
H23B20QABK	220/240-1-50	30/370	88-108/250	25AS	NA	NA	Optional
H23B20SABH	220/240-1-50	35/370	145-175/250	10U	NA	NA	Optional
H23B223ABH	220/240-1-50	30/370	88-108/250	25AS	NA	NA	Optional
H23B22QABH	220/240-1-50	30/370	88-108/250	25AS	NA	NA	Optional
H23B22SABH	220/240-1-50	35/370	145-175/250	10U	NA	NA	Optional
H23B243ABK	220/240-1-50	35/440	88-108/250	10AS	NA	NA	Optional
H23B24QABK	220/240-1-50	35/440	88-108/250	10AS	NA	NA	Optional
H23B24SABH	220/240-1-50	35/370	145-175/250	10U	NA	NA	Optional
H23B263ABK	220/240-1-50	35/370	88-108/250	24AP	NA	NA	Optional
H23B26QABK	220/240-1-50	35/370	88-108/250	24AP	NA	NA	Optional
H23B26SABH	220/240-1-50	40/370	145-175/250	10S	69	16067	Optional

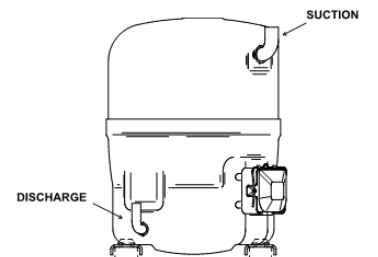

**H23B**

**H23B SERIES 50 Hz (Continued from Previous Page)**

Compressor Model Number	Voltage Phase Hz.	Capacitors		Potential Relays			PTCR Starter
		Run $\mu$ fd/Volts	Start $\mu$ fd/Volts	GE 3ARR3	Mars		
					6-Pak	OEM	
H23B283ABH	220/240-1-50	35/370	88-108/250	24AP	NA	NA	Optional
H23B28QABH	220/240-1-50	35/370	88-108/250	24AP	NA	NA	Optional
H23B28SABH	220/240-1-50	40/370	145-175/250	10S	69	16067	Optional
H23B303ABK	220/240-1-50	45/440	88-108/250	25AS	NA	NA	Optional
H23B30QABK	220/240-1-50	45/440	88-108/250	25AS	NA	NA	Optional
H23B30SABH	220/240-1-50	40/370	145-175/250	10S	69	16067	Optional
H23B323ABK	220/240-1-50	45/370	88-108/250	24AP	NA	NA	Optional
H23B33SABH	220/240-1-50	40/370	145-175/250	10S	69	16067	Optional
H23B35QABK	220/240-1-50	50/440	88-108/250	24R	NA	16057	Optional

**H23B SERIES 60 Hz**

Compressor Model Number	Voltage Phase Hz.	Capacitors		Potential Relays			PTCR Starter
		Run $\mu$ fd/Volts	Start $\mu$ fd/Volts	GE 3ARR3	Mars		
					6-Pak	OEM	
H23B15QABC	230/208-1-60	25/370	88-108/250	3T	69	16068	Optional
H23B15QABH	265-1-60	20/440	88-108/330	10T	69	16073	Optional
H23B17QABC	230/208-1-60	25/370	88-108/250	3P	65	16050	Optional
H23B17QABH	265-1-60	25/370	88-108/330	10U	NA	NA	Optional
H23B19QABC	230/208-1-60	25/370	88-108/250	10S	69	16067	Optional
H23B20QABC	230/208-1-60	25/370	88-108/250	10S	69	16067	Optional
H23B22QABC	230/208-1-60	30/370	88-108/250	10S	69	16067	Optional
H23B22QABH	265-1-60	25/440	88-108/250	25U	66	NA	Optional
H23B24QABC	230/208-1-60	35/370	88-108/250	24P	69	16072	Optional
H23B26QABC	230/208-1-60	35/370	88-108/250	3P	65	16050	Optional
H23B28QABC	230/208-1-60	35/370	88-108/250	10S	69	16067	Optional
H23B28QABH	265-1-60	30/440	88-108/330	10S	69	16067	Optional
H23B30QABC	230/208-1-60	40/370	88-108/250	24P	69	16072	Optional
H23B32QABC	230/208-1-60	45/370	88-108/250	3L	NA	16083	Optional

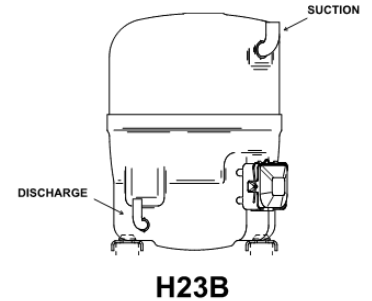

**H23B**

**H24A SERIES 50 Hz**

Compressor Model Number	Voltage Phase Hz.	Capacitors		Potential Relays			PTCR Starter
		Run $\mu$ fd/Volts	Start $\mu$ fd/Volts	GE 3ARR3	Mars		
					6-Pak	OEM	
H24A383ABK	220/240-1-50	40/440	145-175/330	4AA	NA	NA	Optional
H24A423ABK	220/240-1-50	40/440	145-175/330	4AA	NA	NA	Optional

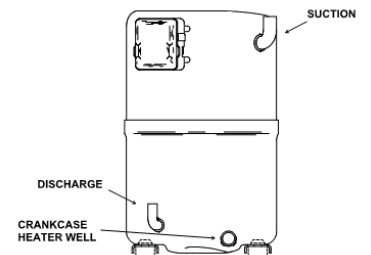

**H24A**

**H24B SERIES 50 Hz**

Compressor Model Number	Voltage Phase Hz.	Capacitors		Potential Relays			PTCR Starter
		Run $\mu$ fd/Volts	Start $\mu$ fd/Volts	GE 3ARR3	Mars		
					6-Pak	OEM	
H24B15QABH	220/240-1-50	20/370	88-108/250	10AT	NA	NA	Optional
H24B17QABH	220/240-1-50	25/370	88-108/250	10AT	NA	NA	Optional
H24B19QABK	220/240-1-50	25/370	88-108/330	25AS	NA	NA	Optional
H24B20QABK	220/240-1-50	25/370	88-108/250	6AW	NA	NA	Optional
H24B22QABH	220/240-1-50	30/370	88-108/250	25AS	NA	NA	Optional
H24B24QABH	220/240-1-50	35/370	88-108/250	25AS	NA	NA	Optional
H24B26QABH	220/240-1-50	35/370	88-108/250	25AS	NA	NA	Optional
H24B28QABH	220/240-1-50	40/370	88-108/250	25AS	NA	NA	Optional
H24B29QABK	220/240-1-50	40/370	88-108/250	24AP	NA	NA	Optional
H24B31QABK	220/240-1-50	45/370	88-108/250	25AS	NA	NA	Optional
H24B32QABK	220/240-1-50	45/440	88-108/250	25AS	NA	NA	Optional

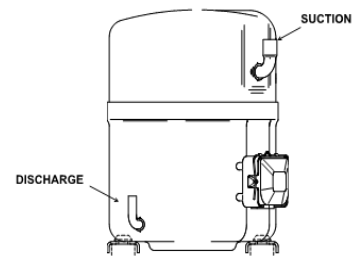

**H24B**

**H24B SERIES 60 Hz**

Compressor Model Number	Voltage Phase Hz	Capacitors		Potential Relays			
		Run $\mu$ fd/Volts	Start $\mu$ fd/Volts	GE 3ARR3	Mars		PTCR Starter
					6-Pak	OEM	
H24B13QABCA	230/208-1-60	15/370	88-108/250	3U	66	16049	Optional
H24B13QABCB	230/208-1-60	15/370	88-108/250	3U	66	16049	Optional

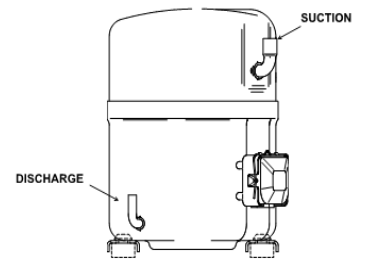

**H24B**

**H28A SERIES 50 Hz**

Compressor Model Number	Voltage Phase Hz.	Capacitors		Potential Relays			
		Run $\mu$ fd/Volts	Start $\mu$ fd/Volts	GE 3ARR3	Mars		PTCR Starter
					6-Pak	OEM	
H28A383ABK	220/240-1-50	50/370	145-175/250	24P	69	16072	Optional
H28A423ABK	220/240-1-50	55/370	145-175/250	24P	69	16072	Optional
H28A473ABK	220/240-1-50	65/440	161-193/250	6AS	NA	NA	Optional

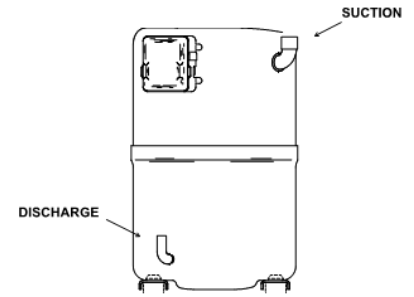

**H28A**

**H28A SERIES 60 Hz**

Compressor Model Number	Voltage Phase Hz	Capacitors		Potential Relays			
		Run $\mu$ fd/Volts	Start $\mu$ fd/Volts	GE 3ARR3	Mars		PTCR Starter
					6-Pak	OEM	
H28A383ABC	230/208-1-60	50/370	145-175/250	3P	65	16050	Optional
H28A423ABC	230/208-1-60	60/370	145-175/250	3P	65	16050	Optional
H28A583CBC	230/208-1-60	60/440	270-324/330	24R*	NA	NA	Optional

\* = 3ARR22 = 50 amp relay

\*All compressors with a "C" in the 8th digit of the model number require PTCR start assist if start capacitor and relay are not used.

**H29A SERIES 60 Hz**

Compressor Model Number	Voltage Phase Hz.	Capacitors		Potential Relays			
		Run $\mu$ fd/Volts	Start $\mu$ fd/Volts	GE 3ARR3	Mars		PTCR Starter
					6-Pak	OEM	
H29A323CBC	230/208-1-60	40/370	270-324/330	3S	NA	16055	305C20
H29A353CBC	230/208-1-60	40/370	270-324/330	3S	NA	16055	305C20
H29A383CBC	230/208-1-60	45/370	270-324/330	3S	NA	16055	305C20
H29A403CBC	230/208-1-60	45/370	270-324/330	3P	NA	16054	305C19
H29A423CBC	230/208-1-60	45/370	270-324/330	3P	NA	16054	305C19
H29A443CBC	230/208-1-60	45/370	270-324/330	3P	NA	16054	305C9
H29A473CBC	230/208-1-60	55/370	270-324/330	3N	NA	16053	305C19
H29A503CBC	230/208-1-60	55/370	270-324/330	3N	NA	16053	305C19
H29A543CBC	230/208-1-60	60/370	270-324/330	3N	NA	16053	305C9
H29A563CBC	230/208-1-60	60/370	270-324/330	3N	NA	16053	305C9
H29A583CBC	230/208-1-60	60/370	270-324/330	24R	NA	16057	305C19
H29A623CBC	230/208-1-60	60/370	270-324/330	24R	NA	16057	305C9

\* = 3ARR22 = 50 amp relay

\*All compressors with a "C" in the 8th digit of the model number require PTCR start assist if start capacitor and relay are not used.

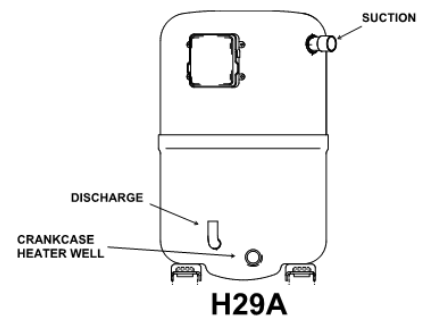

**H29A**

**H29B SERIES 50 Hz**

Compressor Model Number	Voltage Phase Hz.	Capacitors		Potential Relays			
		Run $\mu$ fd/Volts	Start $\mu$ fd/Volts	GE 3ARR3	Mars		PTCR Starter
					6-Pak	OEM	
H29B17UABH	220/240-1-50	30/370	145-175/250	10S	69	16067	Optional
H29B18UABH	220/240-1-50	30/370	145-175/250	10S	69	16067	Optional
H29B20UABH	220/240-1-50	35/370	145-175/250	10U	NA	NA	Optional
H29B22UABH	220/240-1-50	35/370	145-175/250	10U	NA	NA	Optional
H29B24UABH	220/240-1-50	40/370	145-175/250	10S	69	16067	Optional
H29B26UABH	220/240-1-50	40/370	145-175/250	10S	69	16067	Optional
H29B28UABH	220/240-1-50	40/370	145-175/250	3L	NA	16083	Optional
H29B30UABH	220/240-1-50	40/370	145-175/250	10S	69	16067	Optional
H29B32UABH	220/240-1-50	40/370	145-175/250	10S	69	16067	Optional
H29B33UABH	220/240-1-50	40/370	145-175/250	10S	69	16067	Optional
H29B35UABH	220/240-1-50	45/370	145-175/250	10S	69	16067	Optional

**H29B SERIES 60 Hz**

Compressor Model Number	Voltage Phase Hz	Capacitors		Potential Relays			PTCR Starter
		Run $\mu$ fd/Volts	Start $\mu$ fd/Volts	GE 3ARR3	Mars		
					6-Pak	OEM	
H29B13UABC	230/208-1-60	30/370	161-193/250	3V	66	16048	Optional
H29B14UABC	230/208-1-60	30/370	161-193/250	3V	66	16048	Optional
H29B15UABC	230/208-1-60	30/370	161-193/250	3V	66	16048	Optional
H29B16UABC	230/208-1-60	30/370	161-193/250	3V	66	16048	Optional
H29B17UABC	230/208-1-60	30/370	161-193/250	3V	66	16048	Optional
H29B17UABH	265-1-60	25/440	88-108/330	10U	NA	NA	Optional
H29B18UABC	230/208-1-60	30/370	161-193/250	3V	66	16048	Optional
H29B18UABH	265-1-60	25/440	88-108/330	10U	NA	NA	Optional
H29B20UABC	230/208-1-60	30/370	145-175/250	3U	66	16048	Optional
H29B20UABH	265-1-60	30/440	88-108/330	10S	69	16067	Optional
H29B22UABC	230/208-1-60	30/370	145-175/250	3U	66	16049	Optional
H29B22UABH	265-1-60	30/440	88-108/330	10S	69	16067	Optional
H29B24UABC	230/208-1-60	35/370	145-175/250	3T	69	16068	Optional
H29B24UABH	265-1-60	30/440	88-108/330	10S	69	NA	Optional
H29B26UABC	230/208-1-60	35/370	145-175/250	3T	69	16068	Optional
H29B26UABH	265-1-60	30/440	88-108/330	10S	69	NA	Optional
H29B28UABC	230/208-1-60	35/370	145-175/250	3T	69	16068	Optional
H29B28UABH	265-1-60	30/440	88-108/330	10S	69	NA	Optional
H29B30UABC	230/208-1-60	40/370	145-175/250	3P	65	16050	Optional
H29B30UABH	265-1-60	30/440	88-108/330	10S	69	NA	Optional
H29B32UABC	230/208-1-60	40/370	145-175/250	3P	65	16050	Optional
H29B32UABH	265-1-60	30/440	88-108/330	10S	69	NA	Optional
H29B33UABC	230/208-1-60	45/370	243-292/250	3V	66	16048	Optional
H29B33UABH	265-1-60	30/440	88-108/330	10S	69	NA	Optional
H29B35UABC	230/208-1-60	45/370	145-175/250	3N	65	16082	Optional
H29B35UABH	265-1-60	35/440	88-108/330	10S	69	NA	Optional

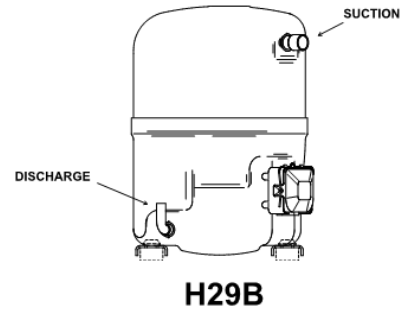

### H2EB SERIES 50 Hz

Compressor Model Number	Voltage Phase Hz	Capacitors		Potential Relays			PTCR Starter
		Run $\mu$ fd/Volts	Start $\mu$ fd/Volts	GE 3ARR3	Mars		
					6-Pak	OEM	
H2EB153ABK	220/240-1-50	25/370	88-108/250	10AU	NA	NA	Optional
H2EB17SABK	220/240-1-50	25/370	88-108/250	25AS	NA	NA	Optional
H2EB193ABK	220/240-1-50	25/370	88-108/250	25AS	NA	NA	Optional
H2EB223ABK	220/240-1-50	35/370	145-175/250	10AT	NA	NA	Optional
H2EB22SABK	220/240-1-50	30/370	145-175/330	10AU	NA	NA	Optional
H2EB243ABK	220/240-1-50	35/370	145-175/250	10AT	NA	NA	Optional
H2EB243ABP	220/240-1-50	35/370	88-108/250	24AP	NA	NA	Optional
H2EB24SABK	220/240-1-50	35/370	145-175/250	10AU	NA	NA	Optional
H2EB263ABK	220/240-1-50	35/370	145-175/250	10AT	NA	NA	Optional
H2EB283ABK	220/240-1-50	40/370	88-108/250	24AP	NA	NA	Optional
H2EB293ABK	220/240-1-50	40/370	145-175/250	24AP	NA	NA	Optional
H2EB29SABK	220/240-1-50	40/370	145-175/250	24AP	NA	NA	Optional
H2EB323ABK	220/240-1-50	45/440	145-175/250	10AT	NA	NA	Optional
H2EB323ABP	220/240-1-50	40/370	88-108/250	24AP	NA	NA	Optional
H2EB32SABK	220/240-1-50	40/370	88-108/250	6AS	NA	NA	Optional

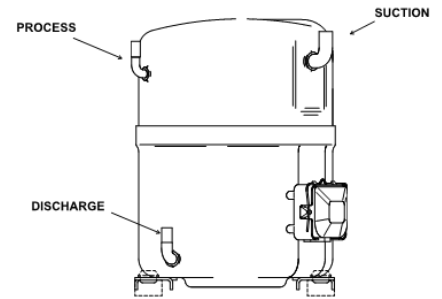

**H2EB**

### H2EB SERIES 60 Hz

Compressor Model Number	Voltage Phase Hz	Capacitors		Potential Relays			PTCR Starter
		Run Ufd/Volts	Start Ufd/Volts	GE 3ARR3	Mars		
					6-Pak	OEM	
H2EB153ABC	230/208-1-60	20/370	88-108/250	3U	66	16049	Optional
H2EB18SABC	230/20/-1-60	25/370	145-175/250	3V	66	16048	Optional
H2EB193ABC	230/208-1-60	25/370	88-108/250	10S	69	16067	Optional
H2EB203ABC	230/208-1-60	25/370	88-108/250	10S	69	16047	Optional
H2EB20SABC	230/208-1-60	25/370	145-175/330	3A	64	NA	Optional
H2EB223ABC	230/208-1-60	25/370	88/108/250	10S	69	16067	Optional
H2EB243ABC	230/208-1-60	35/370	88-108/250	24AP	NA	NA	Optional
H2EB24SABC	230/208-1-60	30/370	145-175/250	10W	NA	NA	Optional
H2EB263ABC	230/208-1-60	35/370	145-175/250	3U	66	16049	Optional
H2EB26SABC	230/208-1-60	35/370	145-175/250	3U	66	16049	Optional
H2EB283ABC	230/208-1-60	45/370	145-175/250	3R	65	NA	Optional
H2EB28SABC	230/208-1-60	45/370	145-175/250	10S	69	16047	Optional
H2EB323ABC	230/208-1-60	45/440	145-175/250	10S	69	16047	Optional
H2EB32SABC	230/208-1-60	45/440	145-175/250	10V	NA	NA	Optional

**H71J SERIES 50 Hz**

Compressor Model Number	Voltage Phase Hz	Capacitors		Potential Relays			
		Run $\mu$ fd/Volts	Start $\mu$ fd/Volts	GE 3ARR3	Mars		PTCR Starter
					6-Pak	OEM	
H71J193ABH	220/240-1-50	35/370	145-175/330	24AV	NA	NA	Optional
H71J193ABK	220/240-1-50	35/370	145-175/330	24AV	NA	NA	Optional
H71J223ABK	220/240-1-50	35/370	145-175/330	3AP	NA	NA	Optional
H71J273ABK	220/240-1-50	45/370	161-193/250	3AM	NA	NA	Optional
H71J323ABK	220/240-1-50	50/370	161-193/250	3AM	NA	NA	Optional
H71J343ABK	220/240-1-50	50/370	161-193/250	3AM	NA	NA	Optional
H71J283ABK	220/240-1-50	50/370	161-193/250	3AN	NA	NA	Optional
H71J433ABK	220/240-1-50	50/370	161-193/250	3S	NA	NA	Optional

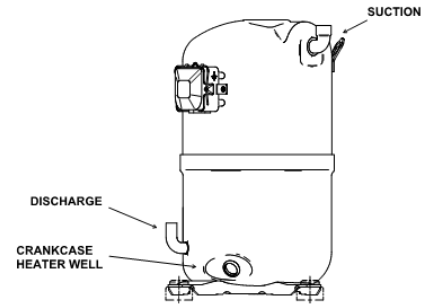

**H71J**

**H71J SERIES 60 Hz**

Compressor Model Number	Voltage Phase Hz	Capacitors		Potential Relays			
		Run $\mu$ fd/Volts	Start $\mu$ fd/Volts	GE 3ARR3	Mars		PTCR Starter
					6-Pak	OEM	
H71J273ABC	230/208-1-60	30/370	145-175/250	3S	69	16068	Optional
H71J343ABC	230/208-1-60	45/370	89-227/330	3S	69	16068	Optional
H71J433ABC	230/208-1-60	50/370	216-259/330	3S	69	16068	Optional
H71J443ABC	230/208-1-60	65/370	216-259/330	3S	69	16068	Optional

**H73A SERIES 50 Hz**

Compressor Model Number	Voltage Phase Hz.	Capacitors		Potential Relays			
		Run $\mu$ fd/Volts	Start $\mu$ fd/Volts	GE 3ARR3	Mars		PTCR Starter
					6-Pak	OEM	
H73A263ABH	220/240-1-50	35/370	145-175/250	10AS	NA	NA	Optional
H73A283ABK	220/240-1-50	35/370	145-175/250	10AS	NA	NA	Optional
H73A303ABH	220/240-1-50	35/370	145-175/250	10AS	NA	NA	Optional
H73A323ABH	220/240-1-50	40/370	145-175/250	10AT	NA	NA	Optional
H73A353ABH	220/240-1-50	35/370	145-175/250	25AV	NA	NA	Optional
H73A383ABK	220/240-1-50	35/440	145-175/330	4AA	NA	NA	Optional
H73A423ABK	220/240-1-50	40/440	145-175/330	27AA	NA	NA	Optional
H73A463ABK	220/240-1-50	40/440	145-175/330	4AA	NA	NA	Optional

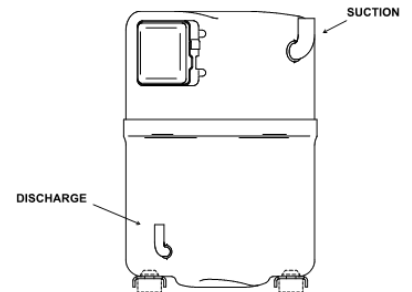

**H73A**

**H73A and H73B SERIES 60 Hz**

Compressor Model Number	Voltage Phase Hz	Capacitors		Potential Relays			
		Run $\mu$ fd/Volts	Start $\mu$ fd/Volts	GE 3ARR3	Mars		PTCR Starter
					6-Pak	OEM	
H73A423ABC	230/208-1-60	40/440	145-175/250	4A	64	16047	Optional
H73A563ABC	230/208-1-60	35/440	135-155/330	6U	65	16062	Optional
H73B17QABC	230/208-1-60	25/370	88-108/250	3P	65	16050	Optional

**H73B SERIES 50 Hz**

Compressor Model Number	Voltage Phase Hz.	Capacitors		Potential Relays			
		Run $\mu$ fd/Volts	Start $\mu$ fd/Volts	GE 3ARR3	Mars		PTCR Starter
					6-Pak	OEM	
H73B17QABH	220/240-1-50	30/370	88-108/250	25AS	NA	NA	Optional
H73B19QABK	220/240-1-50	30/370	88-108/250	10AS	NA	NA	Optional
H73B20QABK	220/240-1-50	30/370	88-108/250	25AS	NA	NA	Optional
H73B22QABH	220/240-1-50	30/370	88-108/250	25AS	NA	NA	Optional
H73B24QABK	220/240-1-50	35/440	88-108/250	10AS	NA	NA	Optional
H73B26QABK	220/240-1-50	35/370	88-108/250	24AP	NA	NA	Optional
H73B28QABH	220/240-1-50	35/370	88-108/250	24AP	NA	NA	Optional
H73B30QABK	220/240-1-50	45/440	88-108/250	25AS	NA	NA	Optional
H73B32QABK	220/240-1-50	45/440	88-108/250	25AS	NA	NA	Optional
H73B35QABK	220/240-1-50	50/440	88-108/250	24R	NA	NA	Optional

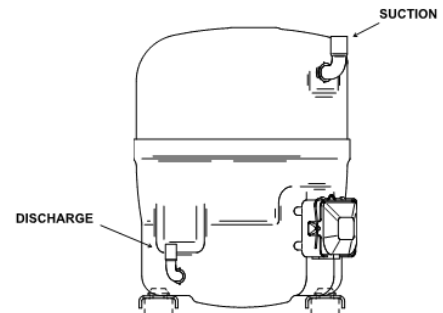

**H73B**

**H78A SERIES 50 Hz**

Compressor Model Number	Voltage Phase Hz	Capacitors		Potential Relays			
		Run $\mu$ fd/Volts	Start $\mu$ fd/Volts	GE 3ARR3	Mars		PTCR Starter
					6-Pak	OEM	
H78A423ABK	220/240-1-50	55/370	145-175/250	24P	69	16072	Optional

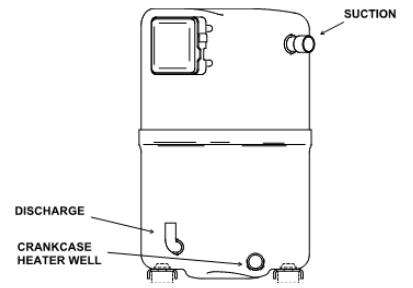

**H78A**

**H79B SERIES 50 Hz**

Compressor Model Number	Voltage Phase Hz	Capacitors		Potential Relays			
		Run $\mu$ fd/Volts	Start $\mu$ fd/Volts	GE 3ARR3	Mars		PTCR Starter
					6-Pak	OEM	
H79B17UABH	220/240-1-50	30/370	145-175/250	10S	69	16067	Optional
H79B18UABH	220/240-1-50	30/370	145-175/250	10S	69	16067	Optional
H79B20UABH	220/240-1-50	30/370	145-175/250	10U	NA	NA	Optional
H79B22UABH	220/240-1-50	35/370	145-175/250	10U	NA	NA	Optional
H79B24UABK	220/240-1-50	35/370	145-175/250	10S	69	16072	Optional
H79B26UABH	220/240-1-50	40/370	145-175/250	10S	69	16072	Optional
H79B26UABK	220/240-1-50	40/370	145-175/250	10S	69	16072	Optional
H79B28UABH	220/240-1-50	40/370	145-175/250	3L	NA	16083	Optional
H79B28UABK	220/240-1-50	40/370	145-175/250	3L	NA	16083	Optional
H79B30UABK	220/240-1-50	40/370	145-175/250	10S	69	16072	Optional
H79B32UABH	220/240-1-50	40/370	145-175/250	10S	69	16072	Optional
H79B32UABK	220/240-1-50	40/370	145-175/250	10S	69	16072	Optional
H79B33UABK	220/240-1-50	40/370	145-175/250	10S	69	16072	Optional
H79B35UABH	220/240-1-50	45/370	145-175/250	10S	69	16072	Optional
H79B35UABK	220/240-1-50	45/370	145-175/250	10S	69	16072	Optional

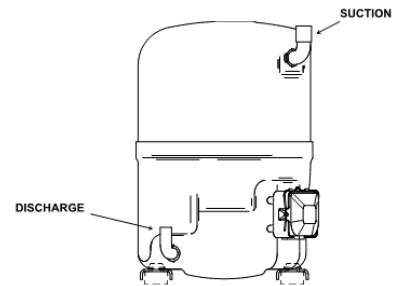

**H79B**

**H79B SERIES 60 Hz**

Compressor Model Number	Voltage Phase Hz	Capacitors		Potential Relays			
		Run $\mu$ fd/Volts	Start $\mu$ fd/Volts	GE 3ARR3	Mars		PTCR Starter
					6-Pak	OEM	
H79B15UABC	230/208-1-60	30/370	161-193/250	3V	66	16048	Optional
H79B17UABC	230/208-1-60	30/370	161-193/250	3V	65	16048	Optional
H79B18UABC	230/208-1-60	30/370	161-193/250	3V	66	16048	Optional
H79B22UABC	230/208-1-60	30/370	145-175/250	3U	66	16049	Optional
H79B26UABC	230/208-1-60	35/370	145-175/250	3T	69	16048	Optional
H79B28UABC	230/208-1-60	35/370	145-175/250	3T	69	16048	Optional
H79B28UABH	265-1-60	30/440	88-108/330	3T	69	16068	Optional
H79B32UABC	230/208-1-60	40/370	145-175/250	3P	65	16050	Optional
H79B35UABC	230/208-1-60	45/370	145-175/250	3N	65	16082	Optional

**H80J SERIES 60 Hz**

Compressor Model Number	Voltage Phase Hz	Capacitors		Potential Relays			
		Run $\mu$ fd/Volts	Start $\mu$ fd/Volts	GE 3ARR3	Mars		PTCR Starter
					6-Pak	OEM	
H80J183ABC	230/208-1-60	30/440	145-175/330	3V	66	16048	Optional
H80J18BABC	230/208-1-60	30/440	145-175/330	3V	66	16048	Optional
H80J223ABC	230/208-1-60	35/440	145-175/330	10U	71	19005	Optional
H80J22BABC	230/208-1-60	35/440	145-175/330	10U	71	19005	Optional
H80J293ABC	230/208-1-60	40/370	243-292/250	3S	69	16068	Optional
H80J29BABC	230/208-1-60	40/370	243-292/250	3S	69	16068	Optional
H80J323ABC	230/208-1-60	45/370	189-227/250	3S	69	16068	Optional
H80J32BABC	230/208-1-60	45/370	189-227/250	3S	69	16068	Optional
H80J383ABC	230/208-1-60	55/370	243-292/250	3N	65	16082	Optional
H80J38BABC	230/208-1-60	55/370	243-292/250	3N	65	16082	Optional

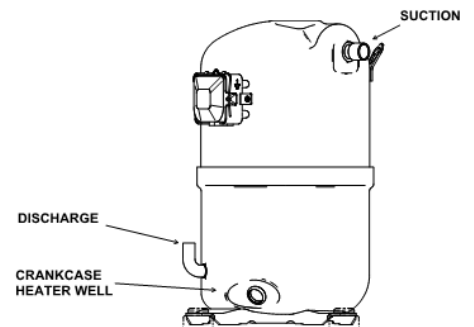

**H80J**

**H81J SERIES 60 Hz**

Compressor Model Number	Voltage Phase Hz	Capacitors		Potential Relays			PTCR Starter
		Run $\mu$ fd/Volts	Start $\mu$ fd/Volts	GE 3ARR3	Mars		
					6-Pak	OEM	
H81J22BABC	230/208-1-60	35/370	145-175/330	3T	69	16068	Optional
H81J283ABC	230/208-1-60	40/370	189-227/330	3L	65	16083	Optional
H81J28BABC	230/208-1-60	40/370	189-227/330	3L	65	16083	Optional
H81J313ABC	230/208-1-60	40/370	243-292/330	3S	69	16068	Optional
H81J31BABC	230/208-1-60	40/370	243-292/330	3S	69	16068	Optional
H81J383ABC	230/208-1-60	55/370	243-292/250	3N	65	16082	Optional
H81J38BABC	230/208-1-60	55/370	243-292/250	3N	65	16082	Optional

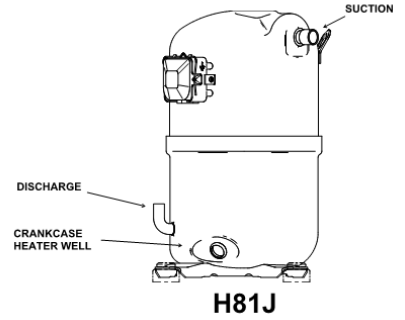

**H82J SERIES 50 Hz**

Compressor Model Number	Voltage Phase Hz	Capacitors		Potential Relays			PTCR Starter
		Run $\mu$ fd/Volts	Start $\mu$ fd/Volts	GE 3ARR3	Mars		
					6-Pak	OEM	
H82J183ABH	220/240-1-50	35/370	145-175/330	3AP	NA	NA	Optional
H82J213ABH	220/240-1-50	35/370	145-175/330	3AP	NA	NA	Optional
H82J223ABH	220/240-1-50	35/370	145-175/330	3AP	NA	NA	Optional
H82J283ABH	220/240-1-50	45/370	163-193/250	3AM	NA	NA	Optional
H82J323ABH	220/240-1-50	40/440	163-193/250	3AM	NA	NA	Optional
H82J373ABH	220/240-1-50	50/370	161-193/250	3AN	NA	NA	Optional

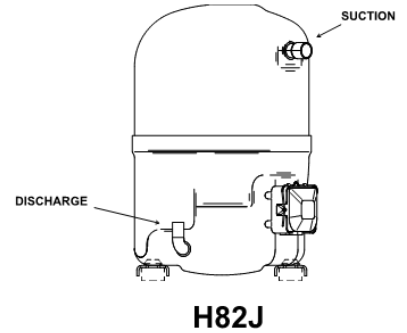

**H82J SERIES 60 Hz (Continued on Next Page)**

Compressor Model Number	Voltage Phase Hz	Capacitors		Potential Relays			PTCR Starter
		Run $\mu$ fd/Volts	Start $\mu$ fd/Volts	GE 3ARR3	Mars		
					6-Pak	OEM	
H82J093ABC	230/208-1-60	35/370	88-108/330	3T	69	16067	Optional
H82J133ABC	230/208-1-60	30/370	145-175/330	3T	69	16067	Optional
H82J13BABC	230/208-1-60	30/370	145-175/330	3T	69	16067	Optional
H82J153ABC	230/208-1-60	30/370	145-175/330	3T	69	16067	Optional
H82J15BABC	230/208-1-60	30/370	145-175/330	3T	69	16067	Optional
H82J183ABC	230/208-1-60	35/370	145-175/330	3T	69	16067	Optional
H82J18BABC	230/208-1-60	35/370	145-175/330	3T	69	16067	Optional
H82J183ABH	265-1-60	30/440	145-175/330	3V	66	18048	Optional
H82J193ABC	230/208-1-60	35/370	145-175/330	3T	69	16067	Optional
H82J19BABC	230/208-1-60	35/370	145-175/330	3T	69	16067	Optional
H82J213ABC	230/208-1-60	35/370	145-175/330	3N	65	16082	Optional
H82J21BABC	230/208-1-60	35/370	145-175/330	3N	65	16082	Optional
H82J213ABH	265-1-60	30/440	145-175/330	3V	66	18048	Optional
H82J223ABC	230/208-1-60	35/370	145-175/330	3N	65	16083	Optional
H82J22BABC	230/208-1-60	35/370	145-175/330	3N	65	16083	Optional
H82J223ABH	265-1-60	30/440	145-175/330	3V	66	18048	Optional
H82J243ABC	230/208-1-60	35/370	145-175/330	3N	65	16082	Optional
H82J24BABC	230/208-1-60	35/370	145-175/330	3N	65	16082	Optional
H82J263ABC	230/208-1-60	40/370	189-227/250	3L	65	16083	Optional
H82J273ABC	230/208-1-60	40/370	189-227/250	3L	65	16083	Optional
H82J283ABC	230/208-1-60	40/370	189-227/250	3L	65	16083	Optional
H82J28BABC	230/208-1-60	40/370	189-227/250	3L	65	16083	Optional
H82J283ABH	265-1-60	35/440	145-175/330	3R	65	16082	Optional
H82J293ABC	230/208-1-60	40/370	189-227/250	3L	65	16082	Optional
H82J29BABC	230/208-1-60	40/370	189-227/250	3L	65	16082	Optional

**H82J SERIES 60 Hz (Continued from Previous Page)**

Compressor Model Number	Voltage Phase Hz	Capacitors		Potential Relays			
		Run $\mu$ fd/Volts	Start $\mu$ fd/Volts	GE 3ARR3	Mars		PTCR Starter
					6-Pak	OEM	
H82J303ABC	230/208-1-60	45/370	189-227/250	3S	69	16068	Optional
H82J323ABC	230/208-1-60	45/370	189-227/250	3S	69	16068	Optional
H82J32BABC	230/208-1-60	45/370	189-227/250	3S	69	16068	Optional
H82J32BABH	265-1-60	35/370	145-175/330	3R	65	16083	Optional
H82J333ABC	230/208-1-60	40/370	189-227/250	3S	69	16068	Optional
H82J33BABC	230/208-1-60	40/370	189-227/250	3S	69	16068	Optional
H82J353ABC	230/208-1-60	40/370	189-227/250	3S	69	16068	Optional
H82J35BABC	230/208-1-60	40/370	189-227/250	3S	69	16068	Optional
H82J373ABC	230/208-1-60	45/440	189-227/250	3S	69	16068	Optional
H82J37BABC	230/208-1-60	45/440	189-227/250	3S	69	16068	Optional
H82J373ABH	265-1-60	50/370	161-193/250	3N	65	16083	Optional
H82J403ABC	230/208-1-60	55/370	189-227/250	3S	69	16068	Optional
H82J423ABC	230/208-1-60	60/370	216-259/330	3S	69	16068	Optional
H82J42BABC	230/208-1-60	60/370	216-259/330	3S	69	16068	Optional
H82J443ABC	230/208-1-60	60/370	216-259/330	3S	69	16068	Optional
H82J44BABC	230/208-1-60	60/370	216-259/330	3S	69	16068	Optional
H82J463ABC	230/208-1-60	60/370	216-259/330	3S	69	16068	Optional
H82J46BABC	230/208-1-60	60/370	216-259/330	3S	69	16068	Optional

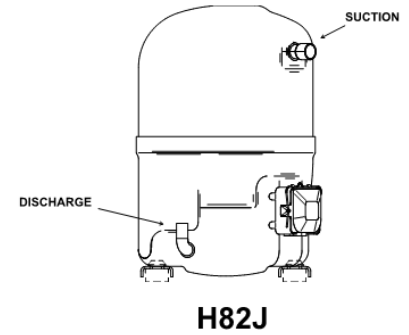

**H89B SERIES 50 Hz**

Compressor Model Number	Voltage Phase Hz.	Capacitors		Potential Relays			
		Run $\mu$ fd/Volts	Start $\mu$ fd/Volts	GE 3ARR3	Mars		PTCR Starter
					6-Pak	OEM	
H89B223ABH	220/240-1-50	40/370	161-193/250	10AS	NA	NA	Optional
H89B283ABH	220/240-1-50	40/370	189-227/250	10AT	NA	NA	Optional
H89B293ABH	220/240-1-50	40/370	189-227/250	10AT	NA	NA	Optional
H89B15UABH	220/240-1-50	30/320	216-259/250	10AA	NA	NA	Optional
H89B18UABH	220/240-1-50	30/320	216-259/250	10AA	NA	NA	Optional
H89B32UABH	220/240-1-50	45/370	270-324/250	10AU	NA	NA	Optional
H89B34UABH	220/240-1-50	45/370	270-324/250	10AU	NA	NA	Optional

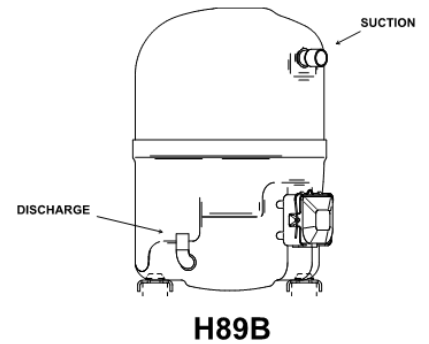

**LOW TEMPERATURE REFRIGERATION 50 AND 60 Hz**

Compressor Model Number	HP (NOM)	Voltage Phase Hz	Capacitors		Potential Relays			
			Run $\mu$ fd/Volts	Start $\mu$ fd/Volts	GE 3ARR3	Mars		PTCR Starter
						6-Pak	OEM	
L63A113BBC	2	230/208-1-60	20/440	161-193/250	26C	67	16058	NA
L63A113BBK	2	220/240-1-50	25/370	161-293/250	10AU	NA	NA	NA
L63A183BBC	3	230/208-1-60	35/440	216-250/330	4B	64	16051	NA
L63A183BBK	3	220/240-1-50	35/440	270-324/330	4AA	NA	NA	NA
L63B562BBA	3/4	115-1-60	20/370	161-193/250	25S	69	16068	NA
L63B562BBC	3/4	230/208-1-60	30/370	161-193/250	3V	66	16048	NA
L63B652BBC	1-1/2	230/208-1-60	30/370	161-193/250	3V	66	16048	NA
L63B752BBC	1-3/4	230/208-1-60	30/370	161-193/250	3V	66	16048	NA
L64A113BBC	1-3/4	230/208-1-60	25/440	189-227/330	4A	64	16047	NA

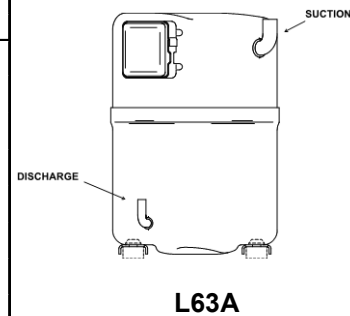

**MEDIUM TEMPERATURE REFRIGERATION 50 Hz**

Compressor Model Number	HP (NOM)	Voltage Phase Hz	Capacitors		Potential Relays			
			Run $\mu$ fd/Volts	Start $\mu$ fd/Volts	GE 3ARR3	Mars		PTCR Starter
						6-Pak	OEM	
M63B123BBK	1-1/2	220/240-1-50	25/370	125-145/250	6AV	NA	NA	NA
M63B153BBK	2-1/2	220/240-1-50	30/370	161-193/250	6AV	NA	NA	NA
M63B203BBK	2-3/4	220/240-1-50	35/370	189-227/250	10AU	NA	NA	NA
M63B872BBK	1	220/240-1-50	25/370	145-175/250	10AB	NA	NA	NA
M63B982BBK	1-1/2	220/240-1-50	25/370	145-175/250	10AT	NA	NA	NA

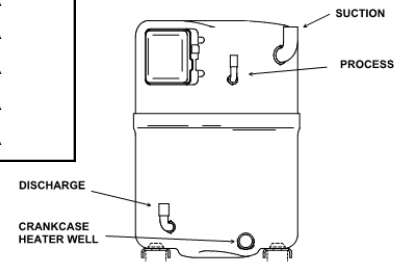

**M63B**

**MEDIUM TEMPERATURE REFRIGERATION 60 Hz**

Compressor Model Number	HP (NOM)	Voltage Phase Hz	Capacitors		Potential Relays			
			Run $\mu$ fd/Volts	Start $\mu$ fd/Volts	GE 3ARR3	Mars		PTCR Starter
						6-Pak	OEM	
M63A243BBC	3	230/208-1-60	35/440	189-227/330	4A	64	16047	NA
M63A273BBC	3	230/208-1-60	35/440	189-227/330	4A	64	16047	NA
M63A323BBC	3	230/208-1-60	45/440	135-155/330	4A	64	16047	NA
M63B123BBC	1-1/2	230/208-1-60	25/440	161-193/250	24T			
M63B153BBC	2-1/2	230/208-1-60	35/440	161-193/250	24T			
M63B203BBC	2-3/4	230/208-1-60	40/440	145-175/250	24T			
M63B872BBC	1	230/208-1-60	25/370	145-175/250	3U	66	16049	NA
M63B982BBC	1-1/2	230/208-1-60	25/370	145-175/250	3U	66	16049	NA

**LOW TEMPERATURE REFRIGERATION 50 Hz**

Compressor Model Number	HP (NOM)	Voltage Phase Hz	Capacitors		Potential Relays			
			Run $\mu$ fd/Volts	Start $\mu$ fd/Volts	GE 3ARR3	Mars		PTCR Starter
						6-Pak	OEM	
L61B452DBL	3/4	220/200-3-50						
L61B562BBK	1	220/240-1-50	15/370	161-193/250	3AV			NA
L61B562DBD	1	220/208-3-50						
L61B562DBE	1	460-3-50						
L61B562DBL	1	220/200-3-50						
L61B652DBD	1-1/2	220/208-3-50						
L61B652DBE	1-1/2	460-3-50						

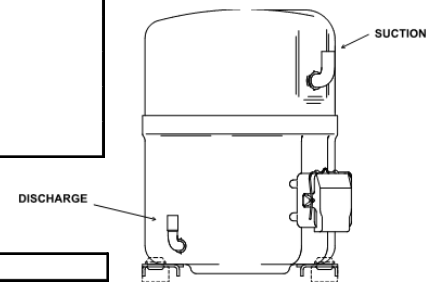

**L61B**

**LOW TEMPERATURE REFRIGERATION 60 Hz**

Compressor Model Number	HP (NOM)	Voltage Phase Hz	Capacitors		Potential Relays			
			Run $\mu$ fd/Volts	Start $\mu$ fd/Volts	GE 3ARR3	Mars		PTCR Starter
						6-Pak	OEM	
L61B452BBC	3/4	230/208-1-60	15/370	189-227/250	24B	64	16051	NA
L61B452BBL	3/4	230/208-3-60						
L61B562BBC	3/4	230/208-1-60	20/370	161-193/250	24B	64	16051	NA
L61B562DBE	1	460-3-60						
L61B562DBL	1	230/208-3-60						
L61B652BBC	1-1/2	230/208-1-60	20/370	161-193/250	3V	66	16048	NA
L61B652DBD	1-1/2	230/208-3-60						
L61B652DBE	1-1/2	460-3-60						
L61B752BBC	1-3/4	230/208-1-60	30/370	161-193/250	3V	66	16048	NA
L61B752DBL	1-3/4	230/208-3-60						

# R92J Product Summary

## R404A Med Temp & R407C/R-22 High Temp

Model	Refrigerant	Voltage	Disp.	Capacity	Watts	EER	RLA	MCC	LRA	Run Cap	Start Cap	Relay
R92J223ABC	R404A	230-1-60	2.539	10725	1665	6.4	9.9	16.0	61.0	30/370	145-175/330	3N
R92J223ABC	R407C	230-1-60	2.539	22350	2100	10.6	10.0	16.0	61.0	30/370	145-175/330	3N
R92J223ABC	R-22	230-1-60	2.539	22500	2050	11.0	9.9	16.0	61.0	30/370	145-175/330	3N
R92J223DBL	R404A	230-3-60	2.539	10700	1700	6.3	6.5	10.5	60.0	N/A	N/A	N/A
R92J223DBL	R407C	230-3-60	2.539	22450	2050	10.9	6.6	13.6	60.0	N/A	N/A	N/A
R92J223DBL	R-22	230-3-60	2.539	22900	2050	11.1	6.5	12.5	60.0	N/A	N/A	N/A
R92J223DBV	R404A	460-1-60	2.539	10600	1720	6.2	3.0	6.0	30.0	N/A	N/A	N/A
R92J223DBV	R407C	460-1-60	2.539	22450	2050	10.9	3.1	6.0	30.0	N/A	N/A	N/A
R92J223DBV	R-22	460-1-60	2.539	22900	2050	11.1	3.3	6.0	30.0	N/A	N/A	N/A
R92J223ABK	R404A	220-1-50	2.539	8750	1405	6.2	6.7	13.0	48.0	35/370	145-175/330	24AV
R92J223ABK	R407C	220-1-50	2.539	15300	1490	10.3	6.5	11.5	48.0	35/370	145-175/330	24AV
R92J223ABK	R-22	220-1-50	2.539									
R92J253ABC	R404A	230-1-60	2.765	12150	1875	6.5	8.7	17.0	61.0	30/370	145-175/250	3S
R92J253ABC	R407C	230-1-60	2.765	25600	2350	10.9	11.8	17.0	61.0	30/370	145-175/250	3S
R92J253ABC	R-22	230-1-60	2.765	25600	2320	11.0	10.7	17.0	61.0	30/370	145-175/250	3s
R92J253DBL	R404A	230-3-60	2.765	12050	1865	6.5	6.3	13.1	63.0	N/A	N/A	N/A
R92J253DBL	R407C	230-3-60	2.765	25400	2315	11.0	7.0	13.4	63.0	N/A	N/A	N/A
R92J253DBL	R-22	230-3-60	2.765	25200	2265	11.1	6.8	13.3	63.0	N/A	N/A	N/A
R92J273ABC	R404A	230-1-60	2.915	13300	1970	6.8	9.0	18.0	61.0	30/370	145-175/330	3S
R92J273ABC	R407C	230-1-60	2.915	27130	2440	11.1	12.5	17.0	61.0	30/370	145-175/330	3S
R92J273ABC	R-22	230-1-60	2.915	27100	2430	11.2	9.0	18.5	61.0	40/370	145-175/330	3S
R92J273DBL	R404A	230-3-60	2.915	13300	1980	6.7	6.3	12.0	63.0	N/A	N/A	N/A
R92J273DBL	R407C	230-3-60	2.915	27230	2446	11.1	7.0	12.5	63.0	N/A	N/A	N/A
R92J273DBL	R-22	230-3-60	2.915	27600	1980	13.9	7.4	12.5	63.0	N/A	N/A	N/A
R92J273DBV	R404A	460-3-60	2.915	13300	1980	6.7	3.2	7.0	30.0	N/A	N/A	N/A
R92J273DBV	R407C	460-3-60	2.915	26850	2390	11.2	3.6	7.0	30.0	N/A	N/A	N/A
R92J273DBV	R-22	460-3-60	2.915	27600	2440	11.3	3.6	7.0	30.0	N/A	N/A	N/A
R92J273ABK	R404A	220-1-50	2.915	11100	1630	6.8	8.0	14.0	64.0	45/370	161-193/250	AM
R92J273ABK	R407C	220-1-50	2.915	23600	2130	11.1	10.0	18.0	64.0	45/370	161-193/250	AM
R92J273ABK	R-22	220-1-50	2.915									
R92J323ABC	R404A	230-1-60	3.281	16200	2380	6.8	10.7	20.2	82.0	45/370	145/175/350	3P
R92J323ABC	R407C	230-1-60	3.281	31500	2880	10.9	12.9	23.4	82.0	45/370	145/175/350	3P
R92J323ABC	R-22	230-1-60	3.281	32000	2870	11.1	12.9	23.2	82.0	45/370	145/175/350	3P
R92J323DBL	R404A	230-3-60	3.281	15980	2385	6.7	8.0	15.9	78.0	N/A	N/A	N/A
R92J323DBL	R407C	230-3-60	3.281	31950	2830	11.3	8.9	16.9	78.0	N/A	N/A	N/A
R92J323DBL	R-22	230-3-60	3.281	31600	2875	11.0	8.9	16.9	78.0	N/A	N/A	N/A
R92J343ABC	R404A	230-1-60	3.531	17600	2550	6.9	11.3	22.0	78.0	40/370	189-227/250	3S
R92J343ABC	R407C	230-1-60	3.531	35200	3100	11.4	13.0	25.1	78.0	45/370	189-227/250	3S
R92J343ABC	R-22	230-1-60	3.531	34200	2980	11.5	13.2	23.0	78.0	45/370	189-227/250	3S
R92J343DBL	R404A	230-3-60	3.531	17550	2535	6.9	8.0	14.0	76.0	N/A	N/A	N/A
R92J343DBL	R407C	230-3-60	3.531	32850	3022	10.9	8.9	15.0	76.0	N/A	N/A	N/A
R92J343DBL	R-22	230-3-60	3.531	34200	2980	11.5	8.9	15.0	76.0	N/A	N/A	N/A
R92J343DBV	R404A	460-3-60	3.531	17400	2510	6.9	4.4	7.0	45.0	N/A	N/A	N/A
R92J343DBV	R407C	460-3-60	3.531	33852	3089	11.0	5.1	8.0	45.0	N/A	N/A	N/A
R92J343DBV	R-22	460-3-60	3.531	34100	2980	11.5	5.0	8.0	45.0	N/A	N/A	N/A
R92J343ABK	R404A	220-1-50	3.531	14000	2050	6.8	14.2	19.0	65.0	50/370	161-193-250	3AM
R92J343ABK	R407C	220-1-50	3.531	29400	2620	11.2	11.0	19.0	65.0	50/370	161-193-250	3AM
R92J343ABK	R-22	220-1-50	3.531	28457	2641	10.8	11.5	19.0	65.0	50/370	161-193-250	3AM
R92J433ABC	R404A	230-1-60	4.31	23300	3285	7.1	15.4	26.0	102.0	50/370	216-259/330	3S
R92J433ABC	R407C	230-1-60	4.31	42986	3841	11.2	17.0	30.0	102.0	50/370	216-259/330	3S
R92J433ABC	R-22	230-1-60	4.31	43500	3830	11.4	17.5	29.0	102.0	65/370	216-259/330	3S
R92J433DBL	R404A	230-3-60	4.31	23300	3270	7.1	10.2	17.0	88.0	N/A	N/A	N/A
R92J433DBL	R407C	230-3-60	4.31	43176	3846	11.2	11.1	18.0	88.0	N/A	N/A	N/A
R92J433DBL	R-22	230-3-60	4.31	42900	3770	11.4	5.7	9.0	88.0	N/A	N/A	N/A
R92J433DBV	R404A	460-3-60	4.31	23200	3270	7.1	5.0	8.0	42.0	N/A	N/A	N/A
R92J433DBV	R407C	460-3-60	4.31	43800	3850	11.4	5.7	9.0	42.0	N/A	N/A	N/A
R92J433DBV	R-22	460-3-60	4.31	42900	3770	11.4	5.7	9.0	42.0	N/A	N/A	N/A
R92J433ABK	R404A	220-1-50	4.31	19300	2725	7.1	12.2	25.0	80.0	55/370	161-193/250	3S
R92J433ABK	R407C	220-1-50	4.31	32710	3101	10.5	14.8	25.0	80.0	55/370	161-193/250	3S
R92J433ABK	R-22	220-1-50	4.31									

### R22 and R410A Pressure Temperature Tables

Sat. T [°F]	R22		R410A	
	[psia]	[psig]	[psia]	[psig]
-20	24.9	10.2	41.0	26.3
-18	26.1	11.4	42.8	28.1
-16	27.3	12.6	44.8	30.1
-14	28.6	13.9	46.8	32.1
-12	29.9	15.2	48.9	34.2
-10	31.2	16.5	51.1	36.4
-8	32.6	17.9	53.3	38.6
-6	34.1	19.4	55.6	40.9
-4	35.6	20.9	58.0	43.3
-2	37.1	22.4	60.5	45.8
0	38.7	24.0	63.0	48.3
2	40.4	25.7	65.6	50.9
4	42.1	27.4	68.4	53.7
6	43.8	29.1	71.1	56.4
8	45.7	31.0	74.0	59.3
10	47.5	32.8	77.0	62.3
12	49.5	34.8	80.0	65.3
14	51.5	36.8	83.2	68.5
16	53.5	38.8	86.4	71.7
18	55.6	40.9	89.8	75.1
20	57.8	43.1	93.2	78.5
22	60.0	45.3	96.7	82.0
24	62.3	47.6	100.4	85.7
26	64.7	50.0	104.1	89.4
28	67.1	52.4	107.9	93.2
30	69.7	55.0	111.9	97.2
32	72.2	57.5	115.9	101.2
34	74.9	60.2	120.1	105.4
36	77.6	62.9	124.4	109.7
38	80.4	65.7	128.8	114.1
40	83.3	68.6	133.3	118.6
42	86.2	71.5	137.9	123.2
44	89.2	74.5	142.6	127.9
46	92.3	77.6	147.5	132.8
48	95.5	80.8	152.5	137.8
50	98.8	84.1	157.6	142.9
52	102.1	87.4	162.8	148.1
54	105.5	90.8	168.2	153.5
56	109.1	94.4	173.7	159.0
58	112.7	98.0	179.4	164.7
60	116.3	101.6	185.1	170.4
62	120.1	105.4	191.0	176.3
64	124.0	109.3	197.1	182.4
66	127.9	113.2	203.3	188.6
68	132.0	117.3	209.6	194.9

Sat. T [°F]	R22		R410A	
	[psia]	[psig]	[psia]	[psig]
70	136.1	121.4	216.1	201.4
72	140.4	125.7	222.7	208.0
74	144.7	130.0	229.5	214.8
76	149.2	134.5	236.5	221.8
78	153.7	139.0	243.6	228.9
80	158.3	143.6	250.8	236.1
82	163.1	148.4	258.3	243.6
84	167.9	153.2	265.9	251.2
86	172.9	158.2	273.6	258.9
88	177.9	163.2	281.5	266.8
90	183.1	168.4	289.6	274.9
92	188.4	173.7	297.9	283.2
94	193.8	179.1	306.3	291.6
96	199.3	184.6	315.0	300.3
98	204.9	190.2	323.8	309.1
100	210.6	195.9	332.8	318.1
102	216.5	201.8	341.9	327.2
104	222.4	207.7	351.3	336.6
106	228.5	213.8	360.9	346.2
108	234.7	220.0	370.6	355.9
110	241.1	226.4	380.6	365.9
112	247.5	232.8	390.8	376.1
114	254.1	239.4	401.1	386.4
116	260.8	246.1	411.7	397.0
118	267.7	253.0	422.5	407.8
120	274.7	260.0	433.5	418.8
122	281.8	267.1	444.8	430.1
124	289.0	274.3	456.3	441.6
126	296.4	281.7	467.9	453.2
128	303.9	289.2	479.9	465.2
130	311.6	296.9	492.1	477.4
132	319.4	304.7	504.5	489.8
134	327.3	312.6	517.1	502.4
136	335.4	320.7	530.0	515.3
138	343.7	329.0	543.2	528.5
140	352.1	337.4	556.7	542.0
142	360.6	345.9	570.4	555.7
144	369.3	354.6	584.4	569.7
146	378.2	363.5	598.7	584.0
148	387.2	372.5	613.2	598.5
150	396.4	381.7	628.1	613.4
152	405.7	391.0	643.3	628.6
154	415.2	400.5	658.8	644.1
156	424.9	410.2	674.7	660.0
158	434.7	420.0	690.9	676.2

## PRESSURE-TEMPERATURE RELATION CHART

PSIG	TEMPERATURE °F						
	R-22	R-502	R-12	134a	R404A	R-407C	
					Saturated Vap/Liq.	Saturated Vapor	Saturated Liquid
5	-48	-57	-29	-22	-57	-41.0	<b>-54.0</b>
4	-47	-55	-28	-21	-56	-39.5	<b>-52.6</b>
3	-45	-54	-26	-19	-54	-38.1	<b>-51.2</b>
2	-44	-52	-25	-18	-53	-36.8	<b>-49.8</b>
1	-43	-51	-23	-16	-52	-35.5	<b>-48.5</b>
0	-41	-50	-22	-15	-50	-34.2	<b>-47.2</b>
1	-39	-47	-19	-12	-48	-31.8	<b>-44.7</b>
2	-44	-52	-25	-10	-46	-29.5	<b>-42.3</b>
3	-34	-42	-14	-8	-43	-27.2	<b>-40.1</b>
4	-32	-40	-11	-5	-41	-25.1	<b>-37.9</b>
5	-30	-38	-9	-3	-39	-23.1	<b>-35.8</b>
6	-28	-36	-7	-1	-37	-21.1	<b>-33.8</b>
7	-26	-34	-4	1	-35	-19.3	<b>-31.9</b>
8	-24	-32	-2	3	-33	-17.5	<b>-30.1</b>
9	-22	-30	0	5	-32	-15.7	<b>-28.3</b>
10	-20	-29	2	7	-30	-14.0	<b>-26.6</b>
11	-19	-27	4	8	-28	-12.4	<b>-24.9</b>
12	-17	-25	5	10	-27	-10.8	<b>-23.3</b>
13	-15	-24	7	12	-25	-9.2	<b>-21.7</b>
14	-14	-22	9	13	-23	-7.7	<b>-20.1</b>
15	-12	-20	11	15	-22	-6.3	<b>-18.6</b>
16	-11	-19	12	16	-20	-4.8	<b>-17.2</b>
17	-9	-18	14	18	-19	-3.5	<b>-15.8</b>
18	-8	-16	15	19	-18	-2.1	<b>-14.4</b>
19	-7	-15	17	21	-16	-0.8	<b>-13.0</b>
20	-5	-13	18	22	-15	0.5	<b>-11.7</b>
21	-4	-12	20	24	-14	1.8	<b>-10.4</b>
22	-3	-11	21	25	-12	3.0	<b>-9.2</b>
23	-1	-9	23	26	-11	4.2	<b>-7.9</b>
24	0	-8	24	27	-10	5.4	<b>-6.7</b>
25	1	-7	25	29	-9	6.6	<b>-5.5</b>
26	2	-6	27	30	-8	7.7	<b>-4.3</b>
27	4	-5	28	31	-6	8.9	<b>-3.2</b>
28	5	-3	29	32	-5	10.0	<b>-2.1</b>
29	6	-2	31	33	-4	11.0	<b>-1.0</b>
30	7	-1	32	35	-3	12.1	<b>0.1</b>
31	8	0	33	36	-2	-13.2	<b>1.2</b>
32	9	1	34	37	-1	14.2	<b>2.2</b>
33	10	2	35	38	0	15.2	<b>3.3</b>
34	11	3	37	39	1	16.2	<b>4.3</b>
35	12	4	38	40	2	17.2	<b>5.3</b>
36	13	5	39	41	3	18.1	<b>6.3</b>
37	14	6	40	42	4	19.1	<b>7.2</b>
38	15	7	41	43	5	20.0	<b>8.2</b>
39	16	8	42	44	6	20.9	<b>9.1</b>
40	17	9	43	45	7	21.8	<b>10.1</b>
42	19	11	45	47	8	23.6	<b>11.9</b>
44	21	13	47	49	10	25.4	<b>13.6</b>
46	23	15	49	51	12	27.1	<b>15.4</b>
48	24	16	51	52	14	28.7	<b>17.0</b>
50	26	18	53	54	16	30.3	<b>18.7</b>
52	28	20	55	56	17	31.9	<b>20.3</b>
54	29	21	57	57	19	33.4	<b>21.9</b>

PSIG	TEMPERATURE °F						
	R-22	R-502	R-12	134a	R404A	R-407C	
					Saturated Vap/Liq.	Saturated Vapor	Saturated Liquid
56	31	23	58	59	20	34.9	<b>23.4</b>
58	32	24	60	60	22	36.4	<b>24.9</b>
60	34	26	62	62	23	37.8	<b>26.3</b>
62	35	27	64	64	25	39.2	<b>27.8</b>
64	37	29	65	65	26	40.6	<b>29.2</b>
66	38	30	67	66	27	42.0	<b>30.6</b>
68	40	32	68	68	29	43.3	<b>31.9</b>
70	41	33	70	69	30	44.6	<b>33.3</b>
72	42	34	71	71	32	45.9	<b>34.6</b>
74	44	36	73	72	33	47.8	<b>36.5</b>
76	45	37	74	73	34	48.4	<b>37.1</b>
78	46	38	76	75	35	49.6	<b>38.4</b>
80	48	40	77	76	37	50.8	<b>39.6</b>
85	51	43	81	79	40	53.7	<b>42.6</b>
90	54	46	84	82	42	56.5	<b>45.4</b>
95	56	49	87	85	45	59.2	<b>48.2</b>
100	59	51	90	88	48	61.8	<b>50.9</b>
105	62	54	93	90	50	64.3	<b>53.5</b>
110	64	57	96	93	<b>52</b>	66.7	<b>56.0</b>
115	67	59	99	96	<b>55</b>	69.1	<b>58.4</b>
120	69	62	102	98	<b>57</b>	71.4	<b>60.8</b>
125	72	64	104	100	<b>59</b>	73.6	<b>63.0</b>
130	74	67	107	103	<b>62</b>	75.8	<b>65.3</b>
135	76	69	109	105	<b>64</b>	77.9	<b>67.5</b>
140	78	71	112	107	<b>66</b>	80.0	<b>69.6</b>
145	81	73	114	109	<b>68</b>	82.0	<b>71.7</b>
150	83	75	117	112	<b>70</b>	83.9	<b>73.7</b>
155	85	77	119	114	<b>72</b>	85.8	<b>75.7</b>
160	87	80	121	116	<b>74</b>	87.7	<b>77.6</b>
165	89	82	123	118	<b>76</b>	89.5	<b>79.5</b>
170	91	83	126	120	<b>78</b>	91.3	<b>81.3</b>
175	92	85	128	122	<b>80</b>	93.1	<b>83.2</b>
180	94	87	130	123	<b>82</b>	94.8	<b>84.9</b>
185	96	89	132	125	<b>83</b>	96.5	<b>86.7</b>
190	98	91	134	127	<b>85</b>	98.1	<b>88.4</b>
195	100	93	136	129	<b>87</b>	99.8	<b>90.1</b>
200	101	95	138	131	<b>88</b>	101.4	<b>91.8</b>
205	103	96	140	132	<b>90</b>	102.9	<b>93.4</b>
210	105	98	142	134	<b>92</b>	104.5	<b>95.0</b>
220	108	101	145	137	<b>95</b>	107.4	<b>98.1</b>
230	111	105	149	140	<b>98</b>	110.3	<b>101.1</b>
240	114	108	152	143	<b>101</b>	113.1	<b>104.1</b>
250	117	111	156	146	<b>104</b>	115.9	<b>106.9</b>
260	120	114	159	149	<b>107</b>	118.5	<b>109.7</b>
275	124	118	163	153	<b>111</b>	122.3	<b>113.7</b>
290	128	122	168	157	<b>115</b>	126.0	<b>117.6</b>
305	132	126	172	161	<b>118</b>	129.5	<b>121.3</b>
320	136	130	177	165	<b>122</b>	132.9	<b>124.9</b>
335	139	133	181	169	<b>126</b>	136.2	<b>128.4</b>
350	143	137	185	172	<b>129</b>	139.4	<b>131.8</b>
365	146	140	188	176	<b>132</b>	142.5	<b>135.0</b>

NOTE: FOR R-407C:

To determine superheat, use saturated vapor values (small figures)  
 To determine subcooling, use saturated liquid values (BOLD figures)

\*Inches of Mercury

To convert °F to °C:  $(°F - 32) \div 1.8 = °C$

## PED LABEL INFORMATION

### Explanation of the European Pressure Equipment Directive (PED) label information (if the compressor is PED-approved):

- The first five digits of the 11-digit serial number give the manufacture and leak test date of the compressor. The first three digits represent the day of the year (for example: 059 = February 28). The next two digits represent the year (for example: 02 = 2002).
- PS is the maximum allowable pressure
- PT is the leak test pressure
- TS (max) is the maximum design temperature
- TS (min) is the minimum design temperature



**BENCHMARK™**

THIS PRODUCT MAY BE COVERED BY ONE OR MORE OF THE FOLLOWING PATENTS AND OTHER PATENTS NOT SHOWN OR PENDING: 6984791, 6803686, 6840746, 6848425, 6900573, 6935848, 6971850, 7200951



**MADE IN USA**

**PART NO.** 700744-1000-00

**MODEL NO.** H2NG204FRDF 0C-16



**(S)** 01293000566



**(P)** GB35JF0020000002



V 230/208	<b>RUN CAP</b>	V 220/200	<b>RUN CAP</b>
Hz 60 PH 3	<b>30/440</b>	Hz 50 PH 3	<b>23/370</b>
LRA 198/282	<b>MFD/VOLTS</b>	LRA 225/320	<b>MFD/VOLTS</b>

**0871**

PS=18.5 BAR    TS(max)= 43°C

PT=20.7 BAR    TS(min)=-40°C

THERMALLY PROTECTED R

REFRIGERANT:  
FLUID GROUP 2 ONLY

# COMPRESSOR MODEL NUMBER SYSTEM

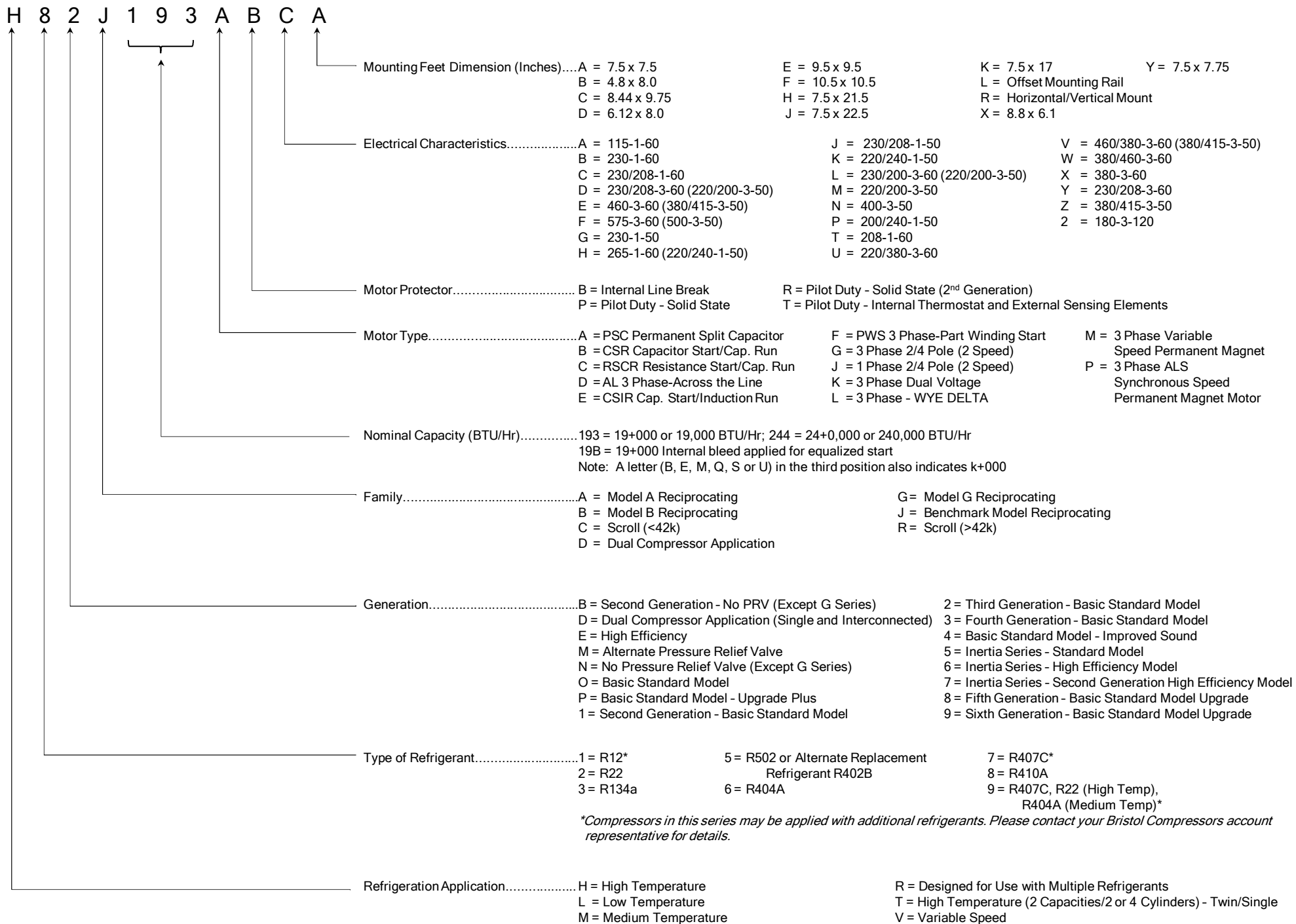

200022  
EN Release 097X01  
EN Revision W12101  
Supersedes EN U27003  
11/12