

8 FT Trampoline

Assembly instruction, installation, use, maintenance and care

USER MANUAL

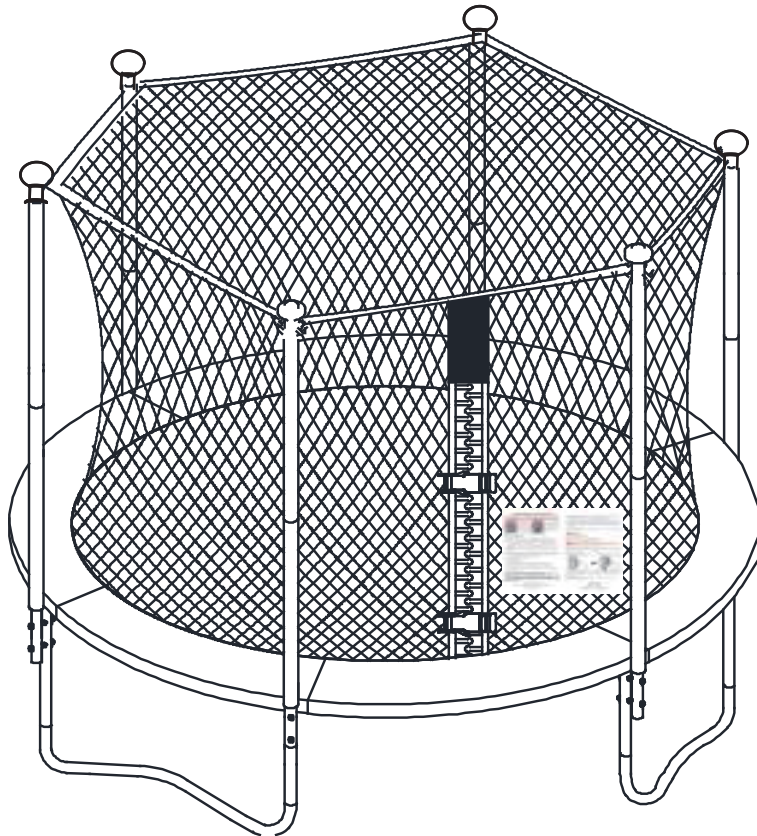

Caution

- Don't try to somersaults or cartwheels. Falling on the head or neck can result in paralysis or even death.
- The maximum user weight should not exceed 130 lbs / 60 Kg for this product. Multiple users can increase the risk of injury.
- Use the trampoline only under the supervision of an adult with knowledge of use. These instructions are for your safety. Please carefully read each of them before assembly and use of the trampoline. We retain this manual for future reference.

Caution



No flips or twists, a fall on the head or Neck can result in paralysis or even death.



Not more than one person at the same time on the trampoline (130lbs / 60 kg).



Do not use in case of plaster or any injury to the leg, ARM, Head, neck or back.



Do not allow the use of the trampoline for children under six (6) years of age.







Remove all sharp or Hard objects such as Jewelry, eyeglasses and / or sunglasses before jumping.





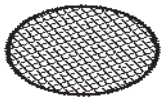

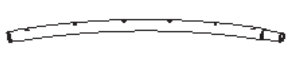

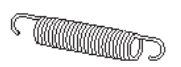
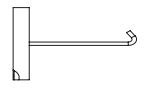
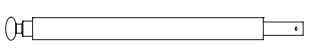
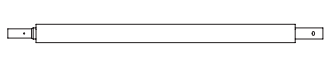
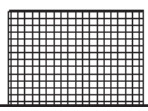
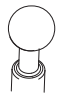



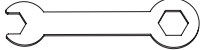
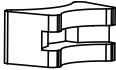

In case of pregnancy, do not use it without your doctor's consent.

Inspection before use, check that the legs are fixed, without Springs Loose, mesh, mat and security are in place and in good condition without scratches.

Part List - Trampoline

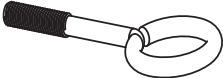
Number	Diagram	Description	Quantity
1		Trampoline Mat	1
2		Frame Pad	1
3		Top Rails with Legs	3
4		Top Rail	3
5		Base Leg	3
7		Galvanized Springs	48
9		Loading Spring Tool	1
10		Top Frame Tube(with foam)	6
11		Bottom Frame Tube(with foam)	6
12		Mesh Cover	1
K1		Strap Circle	6

Part list - Tools

Number	Diagram	Description	Quantity
A		Screw	6
B		Small Spring Wahser	6
C		Allen Tool	1
E		Tool	1
F		Gap Spacer	6
F1		Gap Spacer	6
G		Bolt	6
H		Big Spring Wahser	6
I		Lock Nut	6
J		Arc Washer	6
L		Rope	5
D		Nine word hook	6
H1		Big Spring Wahser	6
I1		Lock Nut	6
J1		Arc Washer	6

Assemble Frame of Trampoline

Before you start: check all the steps before assembling and Read All precautions before using the trampoline. It requires at least two adults to assemble the trampoline. Must use Protective Gloves to avoid injury during the Assembly

Step 1 - Assemble Frame

Locate the following 30 pieces of Steel Tubes that will need to begin to assemble the trampoline:

- 6 - Top rail with Legs (# 3)
- 6 - Top Rails (# 4)
- 6 - Base Leg (# 5)

Note: all parts are interchangeable with the same number and orientation have no right or left.

Make sure you have a spacious, clean and dry place, suitable for the assembly of the trampoline. It is essential that the right place for this trampoline is completely flat and level. If the ground is uneven, this could cause movement in the frame and can cause stress in the united sections of the trampoline and / or can cause serious injury.

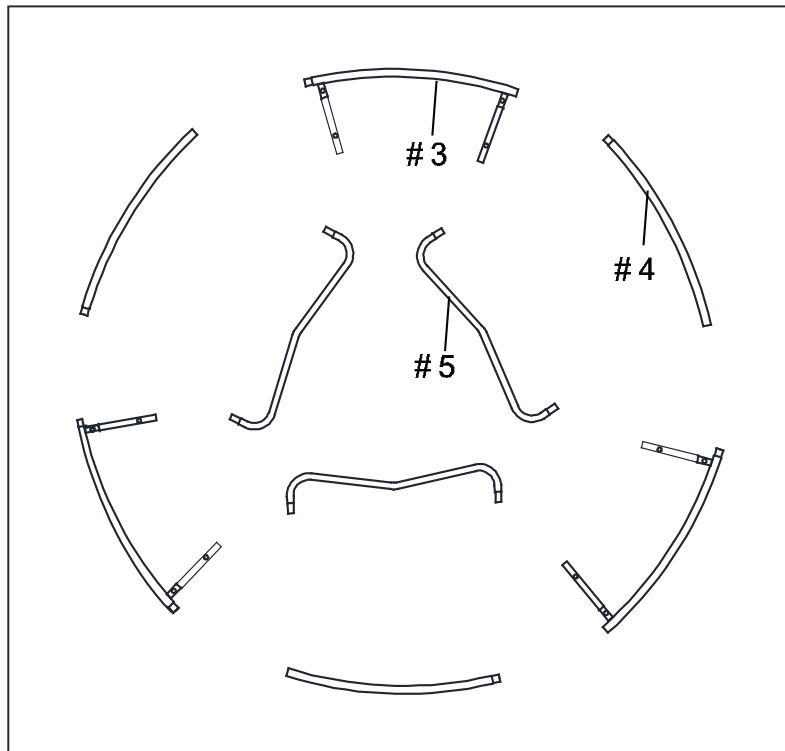

FIGURE 1

Step2 - Main rail Assembly with screw

At this point, two people are needed to assemble the trampoline.

Connect one end of the top rail (# 3) to the vertical extension of the leg (# 5) and the other other end to the vertica leg extension with two holes (# 5) as shown in Figure 3 .

Repeat the same way for all the top Rails with Legs

Tip: Make sure that the holes in all parts of the steel pipe are aligned out: This is important for the following installation of the net.

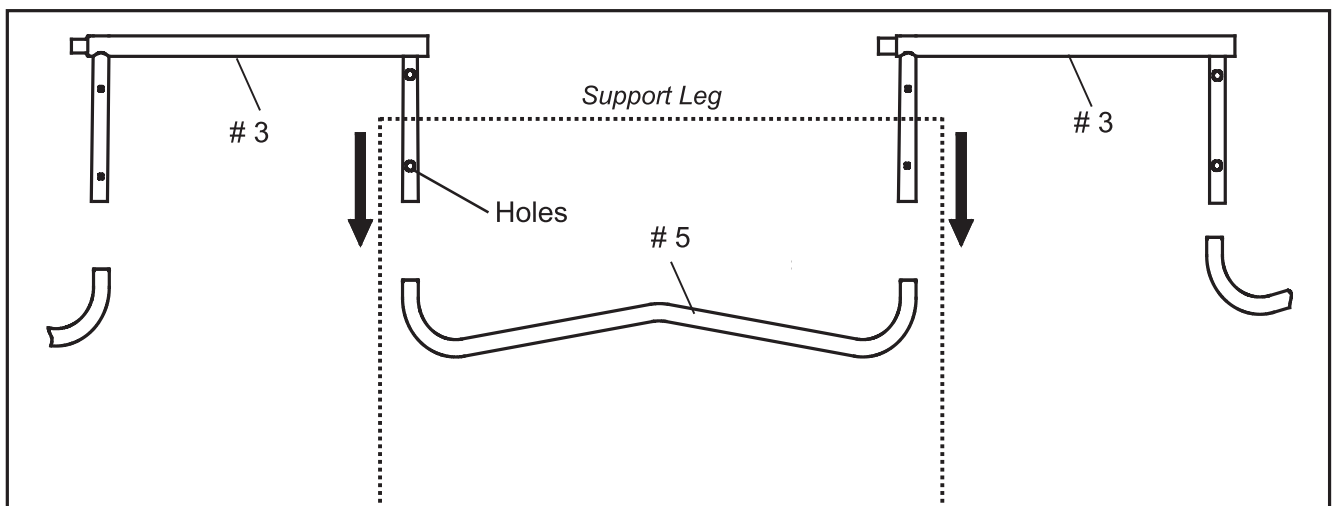
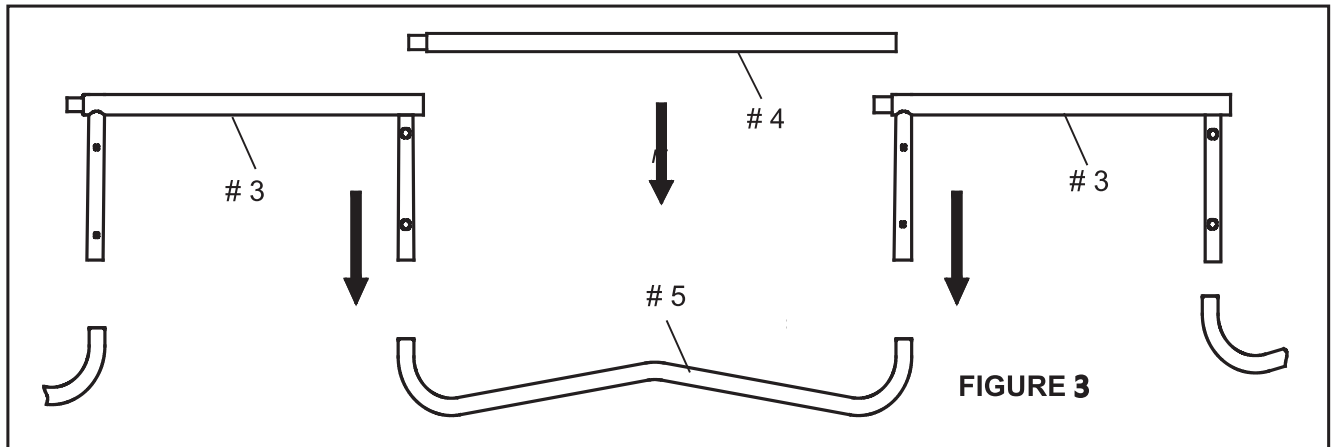

FIGURE 2

Step 3 - Top Rail Assembly

Complete the main frame by inserting top rail (# 4) on top rail (# 3) as shown in Figure 4.



Step 4 - Securing the support leg to the top rail.

NOTE:

The holes on the other side of the support leg will be used later, when installing the cover net - after all the springs (# 7) have been installed (steps 6 - 9).

Tip: make sure that the holes in all the pieces of Steel Pipe Line and the hole is outwards. This is important for the installation of the cover later.

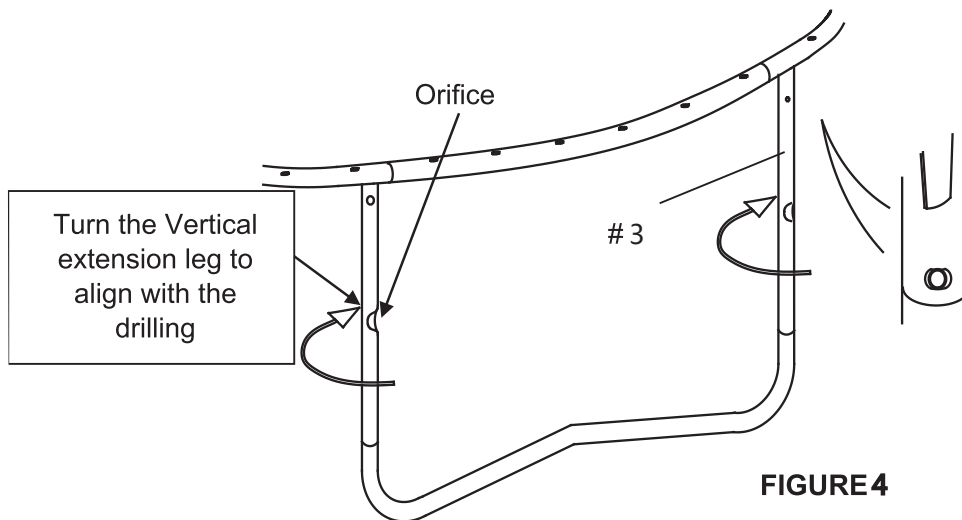

Assembly of the trampoline Mat

To assemble the trampoline Mat, only need the Spring Loading Tool (# 9) included in this product.

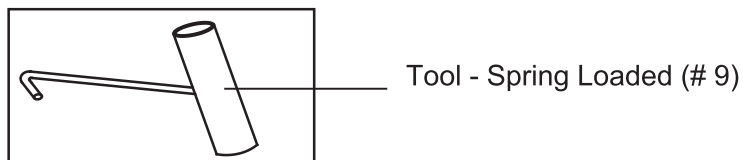

Step 5 - place the Mat

Place the trampoline Mat (#1) on the floor in the Interior of the frame assembled with the Label facing up as shown in Figure 6. Align the warning labels with any of the trampoline legs, make sure that the warning labels are up. This makes the installation process easier.

Select a starting point in the frame and name it "zero" point (pick a point that is above a frame leg and facing a warning label).

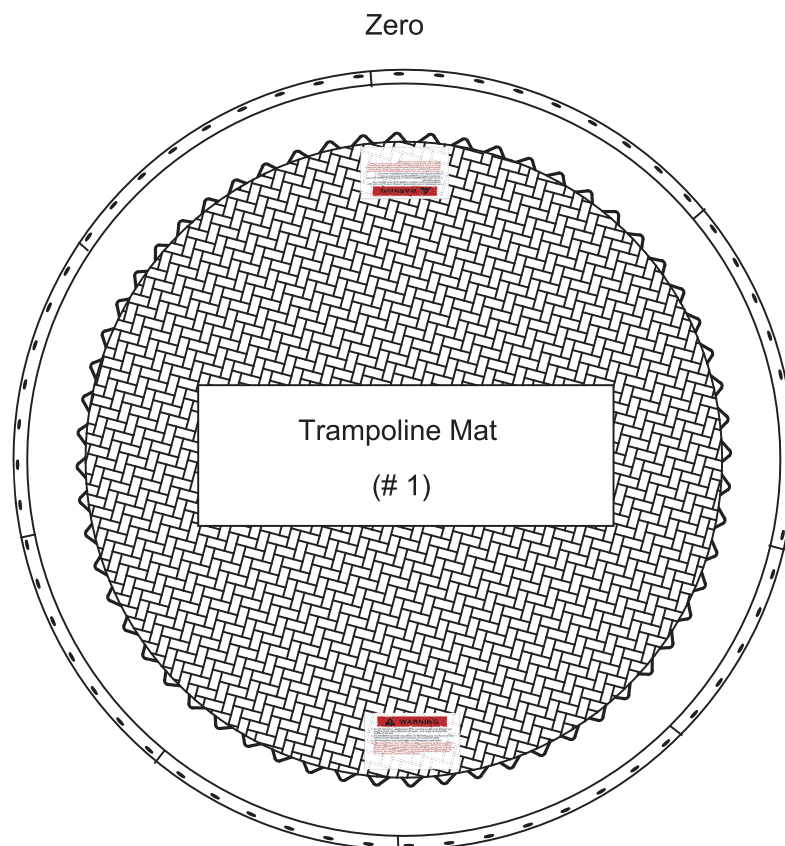

FIGURE 5

STEP 6 - Assemble Springs

By placing the Springs, do not put hands, Arms, Legs or other body part near the connection Points (i.e., joints Connecting Steel Pipe connection points) can become pinched points when the Springs are contracted. Use Heavy Duty work gloves protect your hands from pinching by Springs and Protective Glasses to prevent Eye injury. Make sure that no children playing nearby when joining in springs.

Starting at the "Zero Point", Connect one end of the Spring (# 7) with the spring load tool (# 9) in the triangular ring and pull the other end securing it in the hole of the main frame, as shown in Figure 7.

Tap the end of the spring (# 7) with the handle of the spring load tool to ensure that the springs are securely locked into the hole.

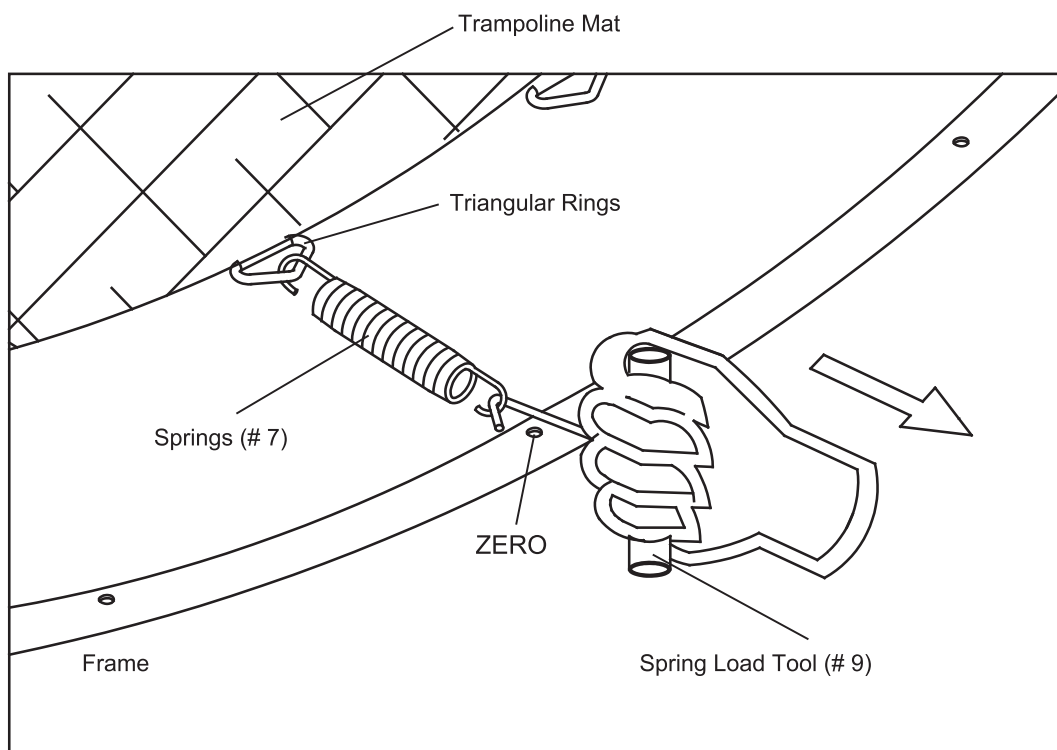

FIGURE 6

Step 7 - Assemble Springs

After having secured the spring in the "Zero Point", Count to 24 holes on the opposite side of the frame and put a Spring in the same way as in the previous step. For a uniform distribution of the spring tension and ease of installation, the springs must always be installed at opposite sides of the main frame of an Alternating Way, i.e., Zero after 24, followed by 12 and 36 as shown in Figure 7.

Tip: the number of triangular Rings sewn in the table is equal to the number of holes in the main frame. Note that if you miscounted a triangular hole or ring, remove and reinstall the Springs in the necessary Place, maintaining a uniform distribution of tension as detailed above.

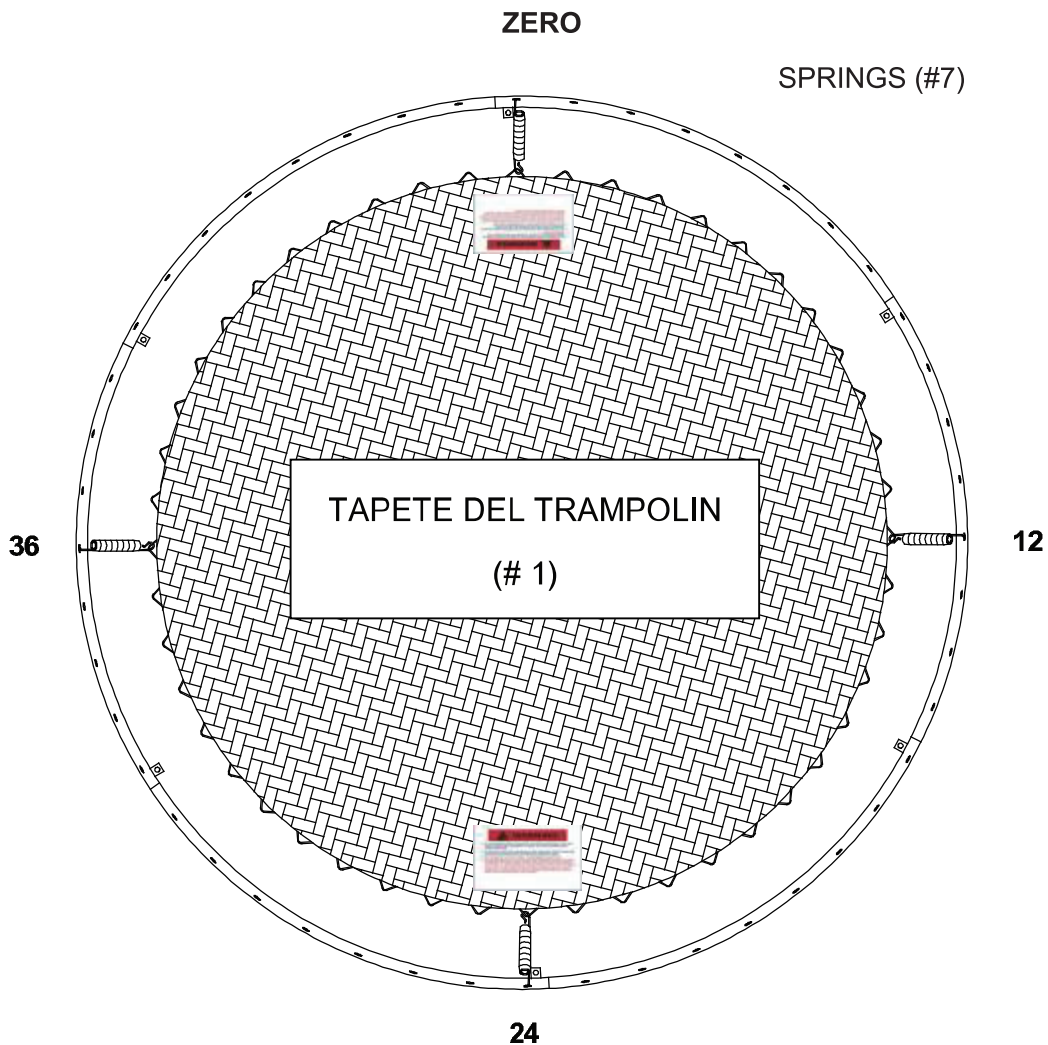

FIGURE 7

Step 8 - Assemble Springs

Place a spring each interval of the sixth hole. For a uniform distribution of tension and ease of assembly, the springs should be placed on opposite sides of the main frame. Alternatively, IE 5 after 22 and 36, 53, etc. besides the Springs above should now have Springs at 4, 8, 16, 20, 28, 32, 40 and 44, as shown in Figure 8.

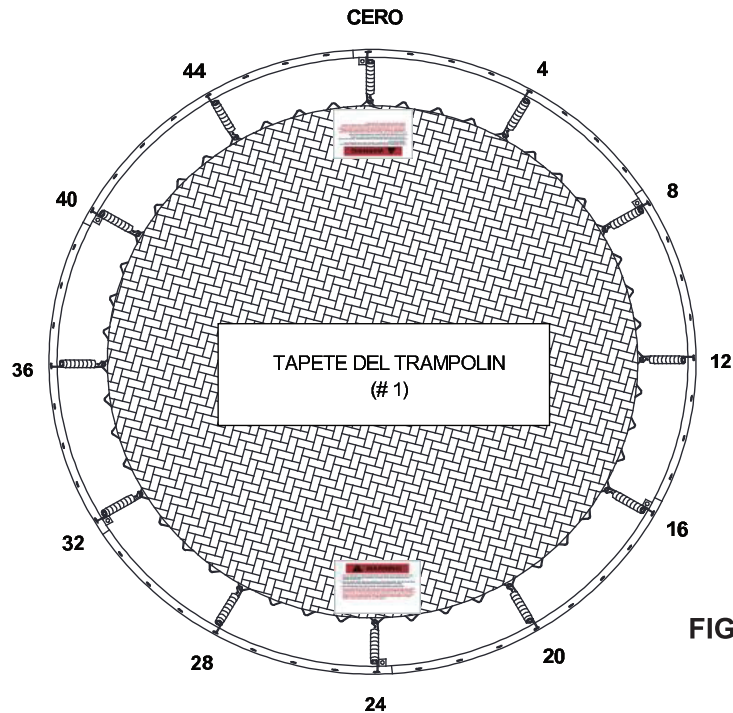

FIGURE 8

Step 9

Continue placing the remaining 50 springs in the same manner as in the previous step. The springs shall be placed on opposite sides of each one to make sure that the trampoline Mat is taut perfectly.

IMPORTANT: you must make sure the springs are perfectly placed and return to step 5 and tighten the screws of the support legs

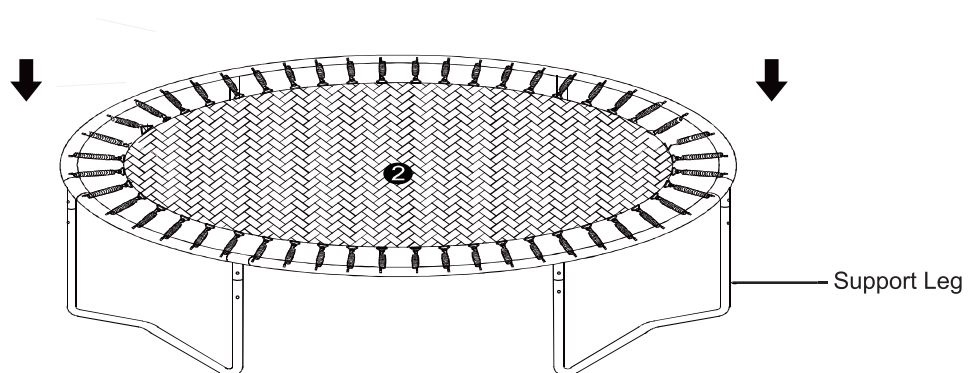
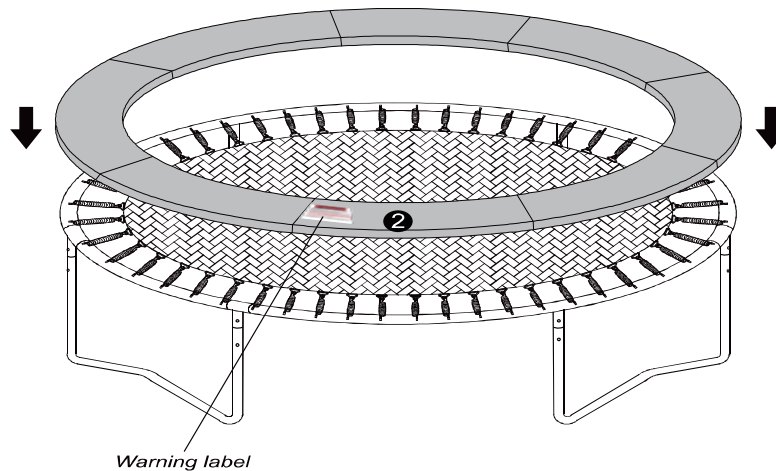

FIGURE 9

Assemble Frame Pad

Never use the trampoline without the frame pad, the pad frame reduces the risk of injury by striking the metal structure. Inspect the cushion frame and metal parts are completely covered by the frame pad before each use.

Note: Please ensure that the warning label is placed between the support leg main frame, as shown below: This is to ensure that the label is in front of the entrance trampoline



Step10

Place the Frame Pad (#2) on the trampoline and fully cover the springs and steel frame. Align the straps to leg sockets and wrap the elastic straps to the connectors of the legs. First, tie a knot and then tie in a bow on one side, as shown in Figure 11. Repeat this step for all the outer bands.

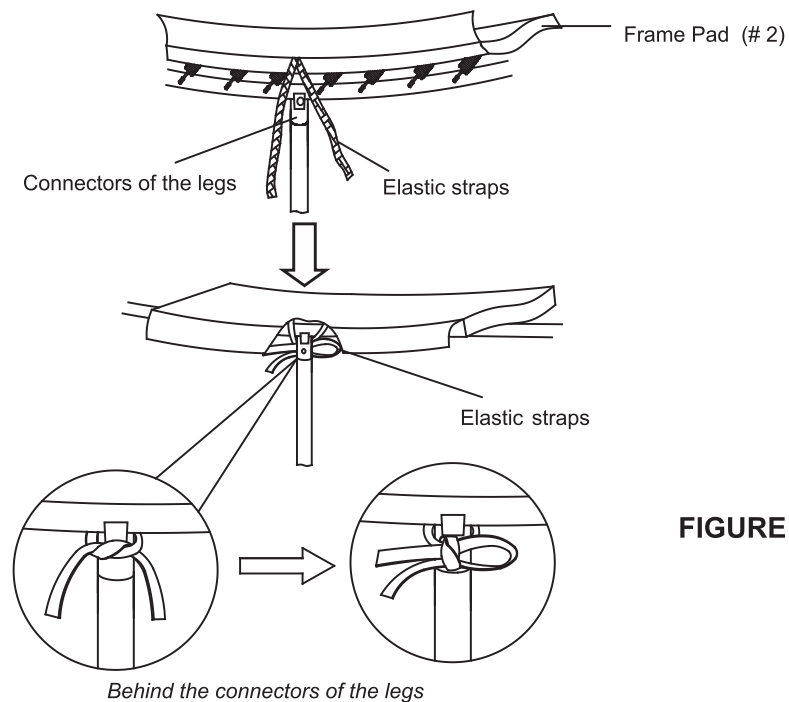

FIGURE 10

Step 11

Finally, wrap the internal elastic straps around triangular ring and tie a knot as shown in the diagram, then tie in a bow on one side as shown in Figure 12. Repeat this step for all inner bands.

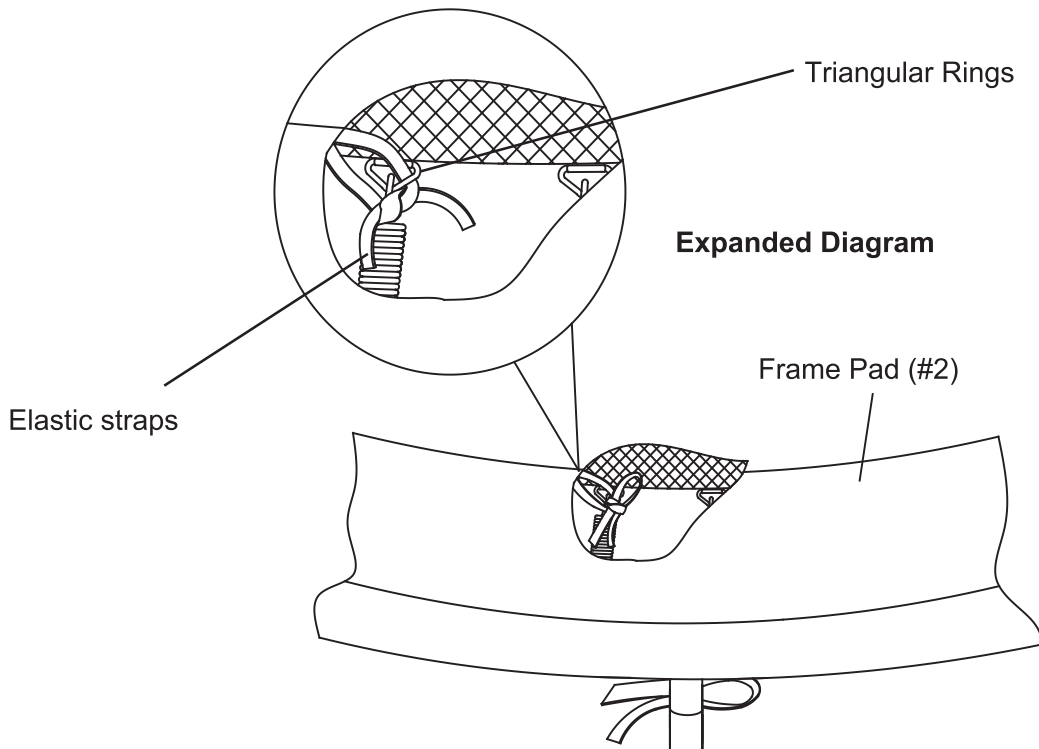

FIGURE 11

Make sure the knots and ties are tight for all elastic straps

Make sure the pad frame is securely installed in the frame and completely covers the frame and all springs before using the trampoline. Do not use the trampoline if a triangular ring fails or is damaged.

Conduct a full Inspection of the trampoline to ensure that all parties are properly assembled.

Read This Manual and make sure you fully understand all warnings in the various Warning signals.

Disassembly of Trampoline

If you have to disassemble the trampoline please follow the assembly instructions in the opposite direction and take special care to keep the parts. Keep the original packaging for transport.

Assembly of the Trampoline Mesh Cover

Before you start:

This trampoline should only be used when the network is assembled correctly. The net of the trampoline must be revised thoroughly before each use to ensure that there are no breakages or damage. PLEASE READ CAREFULLY ALL the important safety instructions in this manual and all warnings on the product before use

Step 12

Place bottom frame tube (with foam) (# 11) next to the support leg(i.e., the side with the 2 Holes) and secure it with the screw bolt (#G) , gap spacer (#F) , arc wahser (#J) , big spring wahser (#H) and Lock Nut(#I) as shown in Figure 12.

Repeat this step for the rest 4 bottom frame tubes(with foam)

Place lower board tube (# 11) next to the last support leg and secure it with the screw bolt (# D) , gap spacer (#F1), arc wahser (#J1), big spring wahser (#H1)and Lock Nut(#I1)

Enclosure Net Tubes Assembly Diagram

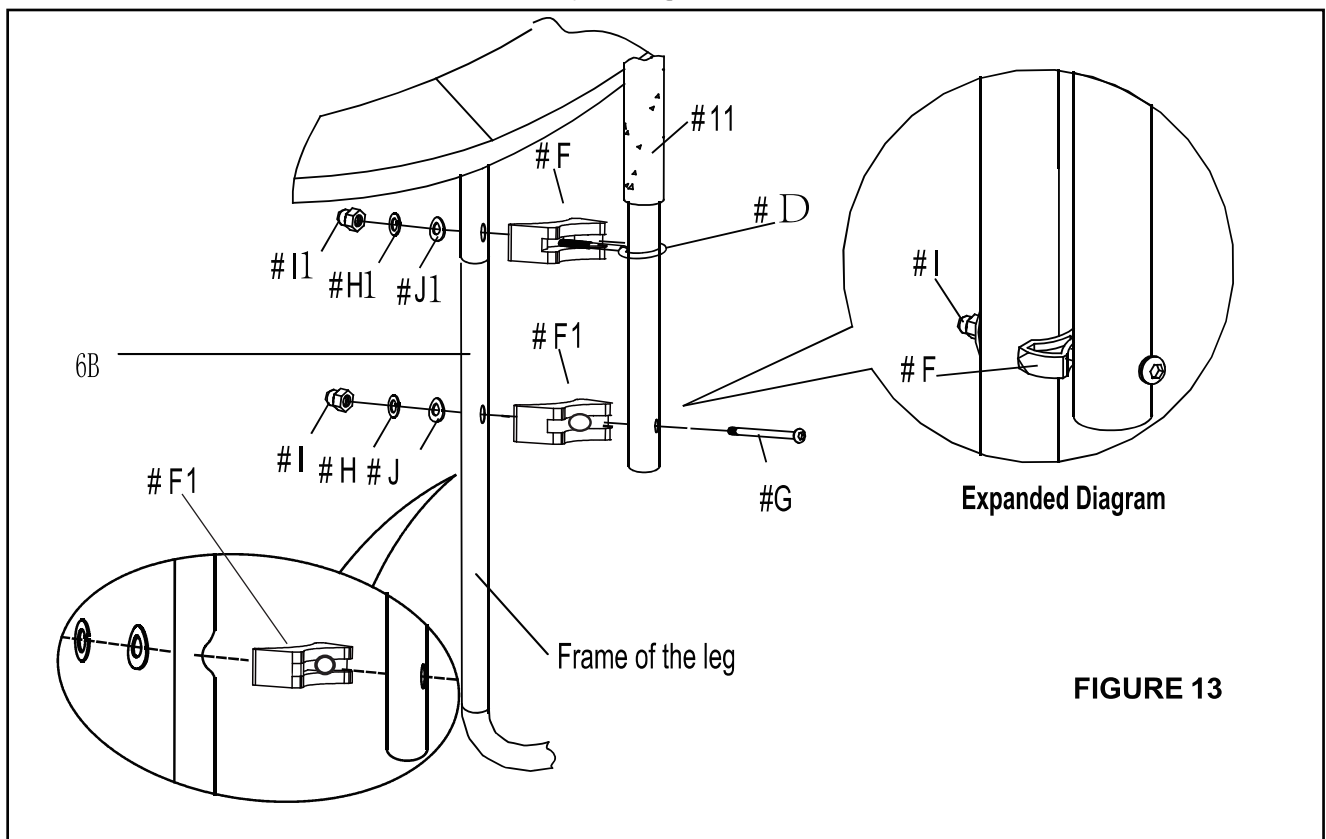

FIGURE 13

Connect Top Frame Tube (#10) and Bottom Frame Tube (#11) with screw (#A), Small Spring Wahser (#B) and Allen tool (#C),

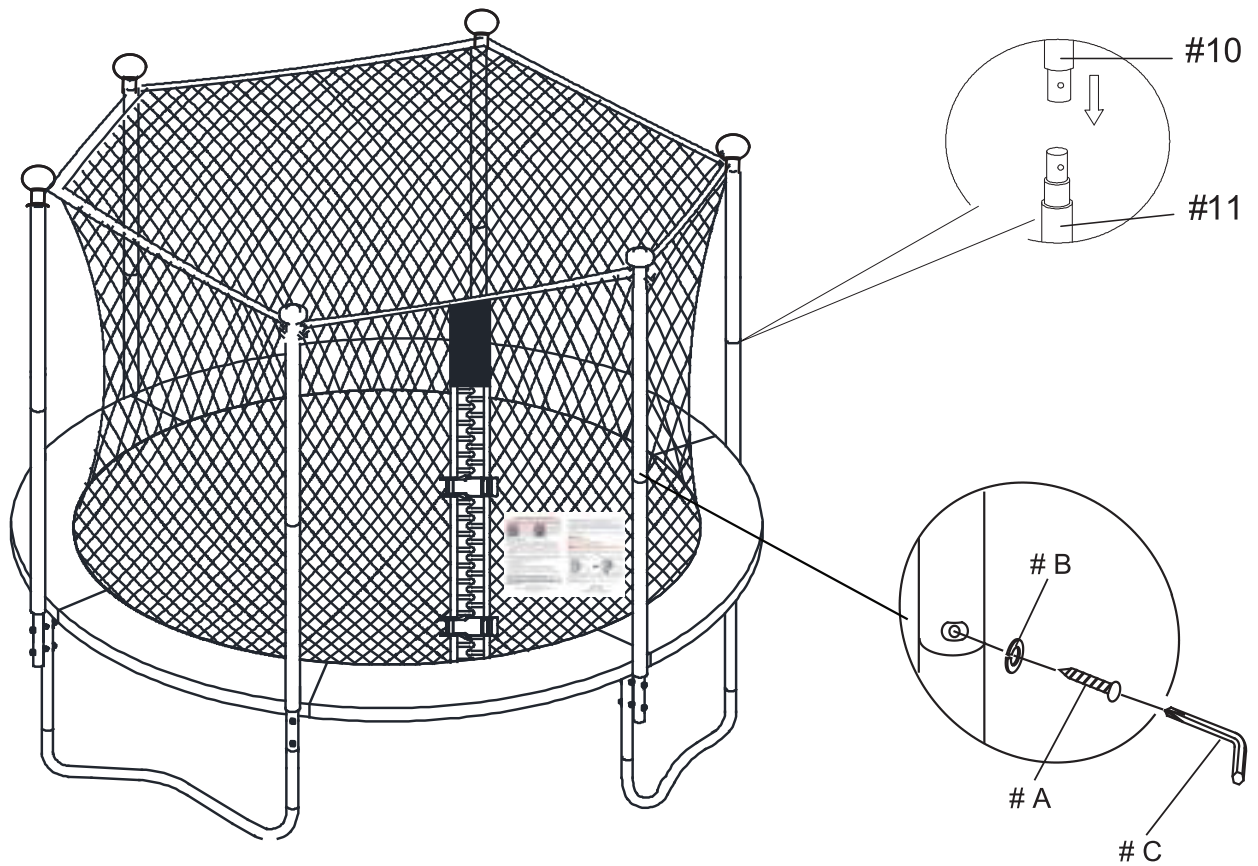

FIGURE 13

Connect Top Frame Tube (#10) and Bottom Frame Tube (#11) with screw (#A), Small Spring Wahser (#B) and Allen tool (#C)

Install the strap circle to the top of the frame (# K1) as shown and then tie the other end of the strap to the top(# K1). Please make sure the door is closing at the zero point

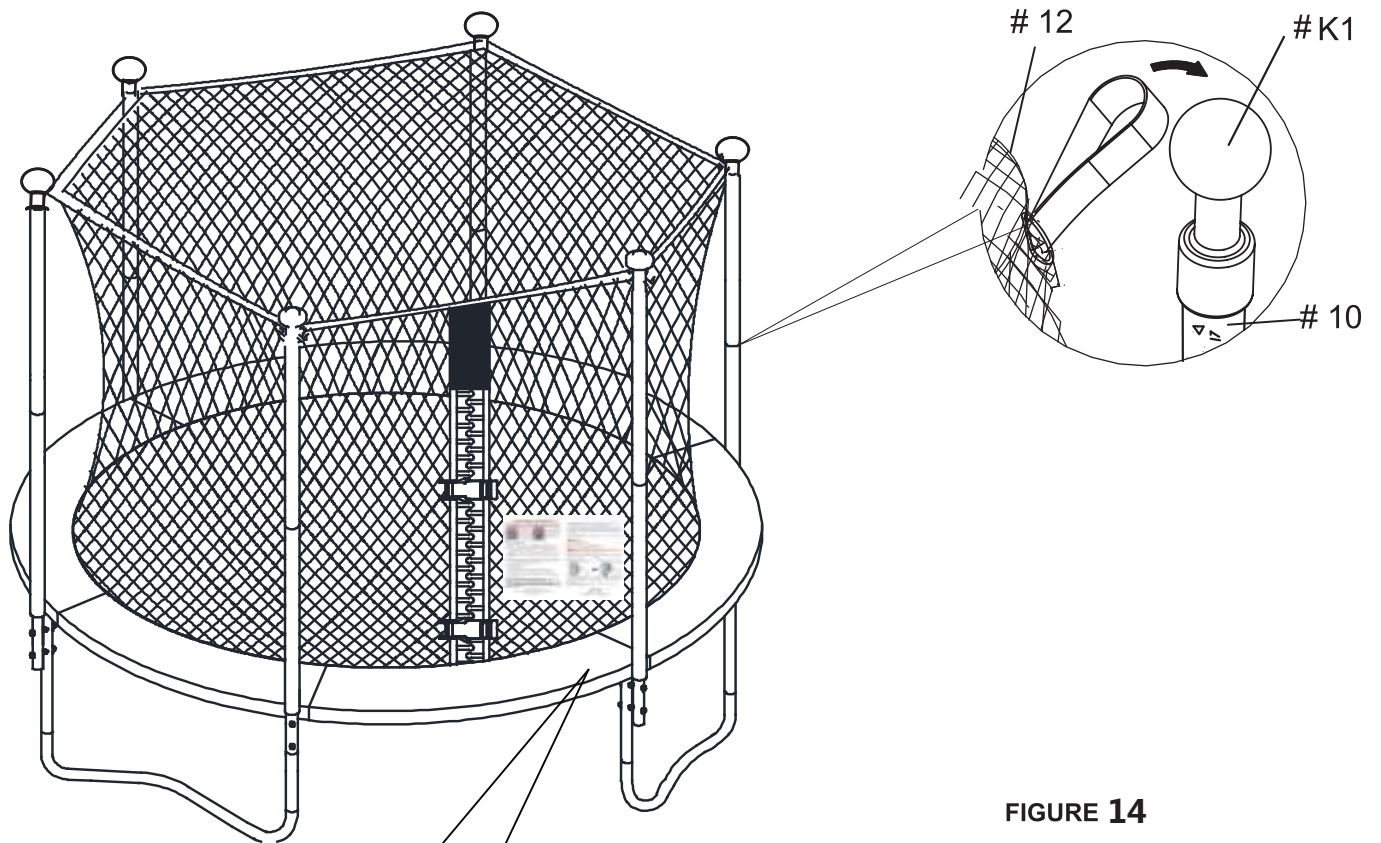
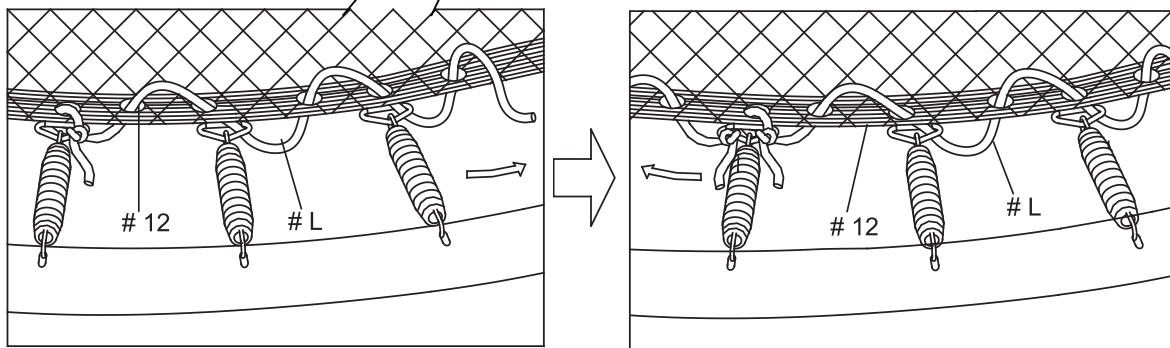

FIGURE 14



Step15

Tie the end of the cable (# L) to the first ring of the trampoline, pull cord (# L) through all the rings on the trampoline frame, then tie the two ends of the rope together.

Step16

Pull the trampoline enclosure (# 12) to the door, then press two buckles as (the bottom of the buckle not shown) shown in FIGURE 17.

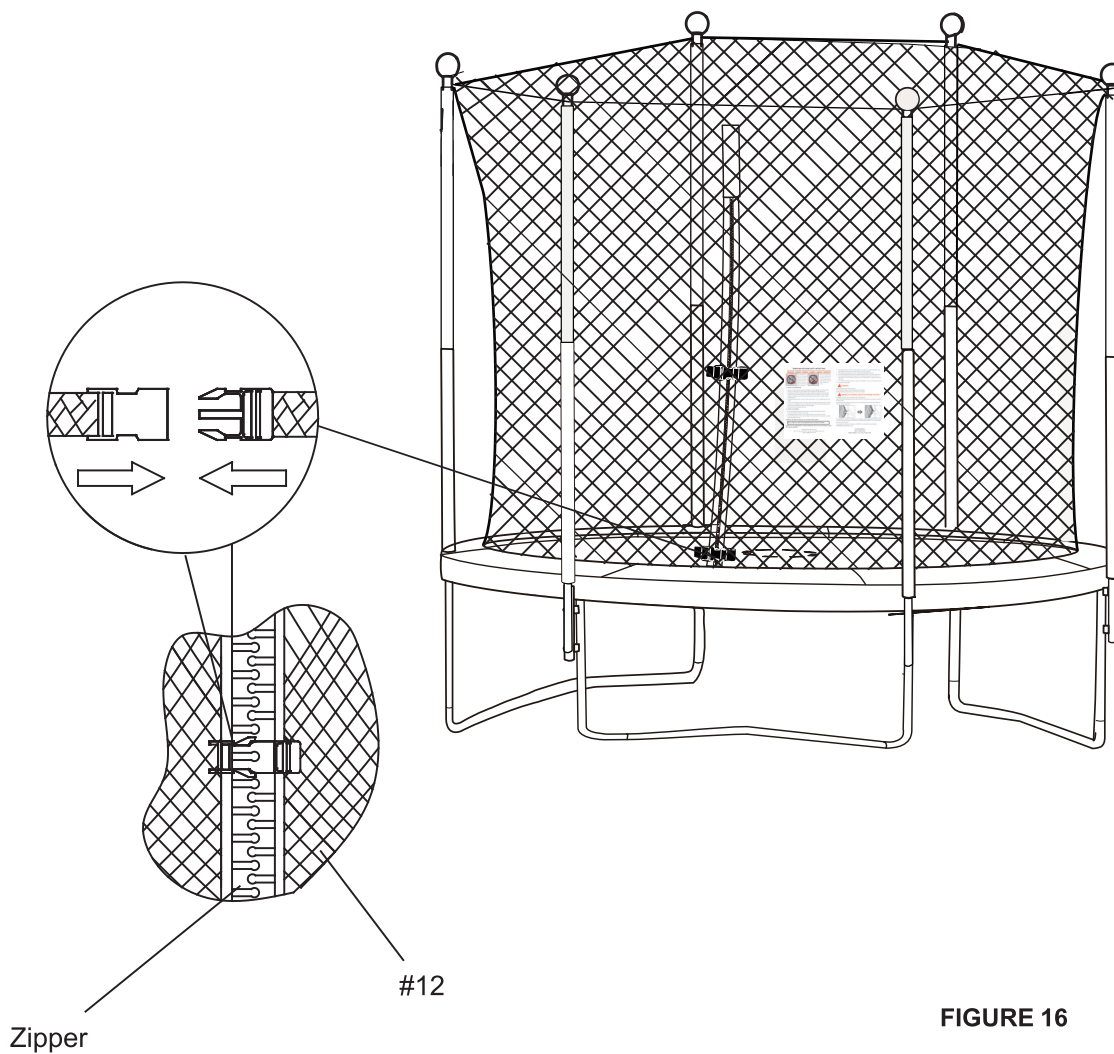

Make sure the trampoline is on a flat, level surface with adequate safety distances in case you need to move from place to place. If you have to remove the trampoline please follow the assembly instructions in reverse and take special care to keep the parts. Keep the original packaging for transport.

TRAMPOLINE AND ENCLOSURE CARE AND MAINTENANCE

To avoid damage to the trampoline and enclosure, do not allow pets or animals inside the enclosure.

The trampoline is intended to be used by one person at a time who weighs not more than 300 pounds. The user should be either barefoot, wearing socks, or wearing gymnastic shoes. Street shoes or tennis shoes should not be worn on the trampoline. The user should remove all sharp objects from his or her person that may cause injury or damage to the mat. Heavy, sharp, or pointed hard objects should never touch the mat.

Continued exposure over a long period of time to the sun, especially to ultraviolet rays, will shorten the life of the enclosure fabric. For longer fabric life, store the enclosure when it is not being used. A dry enclosure, properly stored, will provide the longest life of the fabric, sewing, and hardware. Remove the enclosure from the trampoline during harsh weather conditions or during long periods of non-use.

MAINTENANCE

Your trampoline was manufactured using quality materials and crafted to provide you and your family with many years of enjoyment and exercise. Proper maintenance and care will help to prolong the life of the trampoline and reduce the possibility of injury. The following guidelines should always be followed.

Inspect the trampoline enclosure before each use, and replace any worn, defective, or missing parts. The following conditions could represent potential hazards and increase the danger of personal injury:

- missing, improperly positioned, or insecurely attached frame padding, netting, enclosure tubes, or foam sleeves
- punctures, frays, tears, or holes worn in the mat, frame padding, netting or foam sleeves
- deterioration in the stitching or fabric of the mat, frame padding or netting
- ruptured or missing springs
- bent or broken frame, leg or enclosure tubes
- sagging bed or netting
- sharp protrusions on the frame, suspension system or enclosure tubes

If any of these conditions exist, the trampoline and/or enclosure should be disassembled (taken apart) or otherwise protected from being used until the condition is fixed.

SPECIAL CONSIDERATIONS

High Wind

It is possible for the trampoline and enclosure to be blown about by high winds. If you expect high winds, move the trampoline and enclosure to a sheltered location. Disassemble (take down) the enclosure netting. Tie the trampoline frame down to the ground using ropes and stakes (not included). At least three ropes and three stakes should be used. Make sure to attach the ropes to the top of the trampoline frame: do not simply secure the legs or the bases to the ground as they can separate from the frame sockets. The tops of the stakes should be at ground level so that they will not create a tripping hazard. In addition, the tops of the stakes should be covered, if necessary, so that users will not be hurt by falling onto the stakes.

Moving the Trampoline and Enclosure

If the trampoline and enclosure needs to be moved, it should be moved by two persons, kept horizontal, and lifted slightly. If necessary, the trampoline and enclosure can be taken apart for moving. To take the trampoline apart, follow the assembly steps in reverse order (see pages 13 to 20). Do not attempt to take the frame sections, legs, or bases apart before the mat and springs have been removed.

BASIC TRAMPOLINE SKILLS

Fundamental Bounce

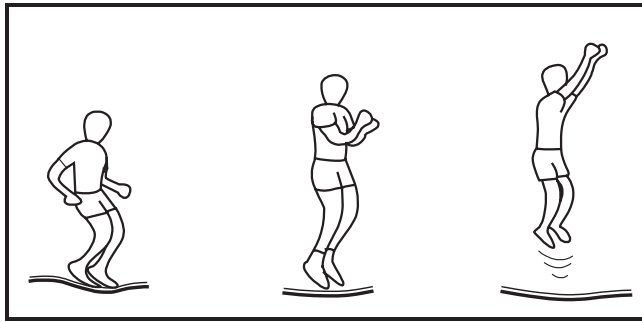

1. Start from a standing position with your head erect and your eyes on the frame pad.
2. Swing your arms forward and up in a circular motion.
3. Bring your feet together and point your toes downward while in the air.
4. Keep your feet about 15 inches apart when landing on the mat.

Knee Drop

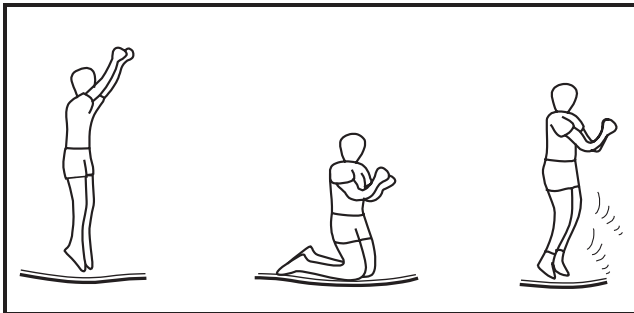

1. Start bouncing from a standing position, keeping your eyes on the frame pad.
2. Land on your knees, keeping your back straight and your body erect.
3. Come back up to an erect position.

Seat Drop

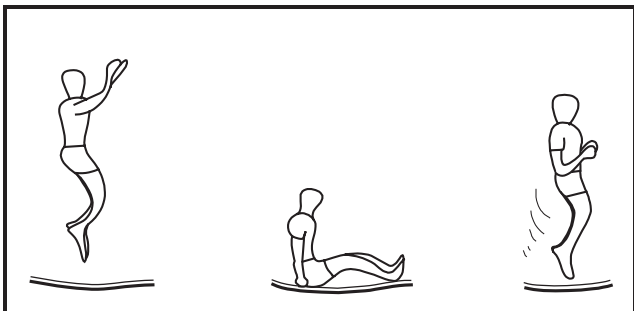

1. Land in a sitting position with your legs parallel to the mat.
2. Place your hands on the mat beside your hips.
3. Push with your hands to return to an erect position.

Front Drop

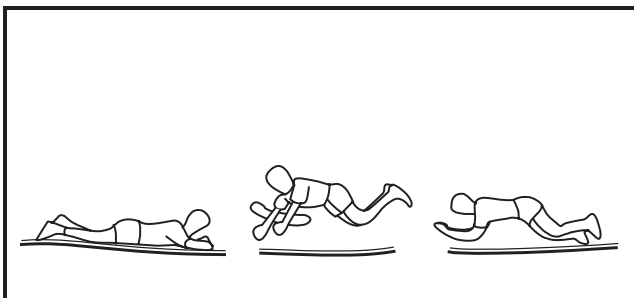

1. Start from a low bounce and land on the mat in a prone position.
2. Keep your head up and your arms extended forward on the mat.
3. Push with your arms to return to an erect position.