

# **Wall-mounted Bathtub Faucet Installation Manual**

**W-65(ES)**

# Warranty Duration

All parts of this faucet system are warranted to the original purchaser to be free from defects in material and workmanship under a lifetime limited warranty.

# Repair and Replacement

If the product exhibits defects in material or workmanship under normal use and within the warranty coverage, we will, at our discretion, either repair the product or provide a replacement at no cost to the original purchaser. Please note that proof of purchase (e.g., an invoice) must be presented when requesting service. The warranty does not cover damages resulting from improper installation, misuse, or modifications.

# Exclusions

We shall not be responsible for the following cases:

- Damage to the product caused by improper installation, misuse, unauthorized repair or replacement, or abuse (including damage during shipment).
- Damage to the product caused by improper dismantlement after installation.
- Damage resulting from abnormal water pressure and impurities in water pipes is not covered under this warranty.
- Rust on the product due to insufficient care and maintenance is not covered under this warranty.
- Damage caused by natural disasters such as fire, flood, earthquake, electric storms, etc., is not covered under this warranty.

I hope this helps! If you have any further questions or concerns, please let me know.

# Having Trouble? Contact us.

✉ Email: [info@faucetsupport.com](mailto:info@faucetsupport.com)

☎ Toll Free: 1-888-969-6880



**SFS-1107**  
**M5218**  
**Model:A**

## **CONTENT**

<b>1.Installation Condition</b>	-----	<b>1</b>
<b>2.Concealed hot and cold bathtub faucet part List(Model:A)</b>	-----	<b>2</b>

## **CONTENIDO**

<b>1.Condición de instalación</b>	-----	<b>6</b>
<b>2.Grifo de bañera oculto de agua caliente y fría Lista de piezas (Modelo: A)</b>	-----	<b>7</b>

## ◆ Installation and maintenance matters

1. Check the accessories list to verify that all parts are complete in this package.
2. Do not disassemble the main body by yourself.
3. Connect inlet pipes to supply valves.
4. Make sure inlet pipes and supply valves have no impurities and are cleaned, with no impurities in the pipeline.
5. After installation, check all joints for leakages.
6. Do not leave the rain shower system exposed to a severely corrosive environment.

### Do's

1. In order to keep the mixer surface bright, please clean the mixer regularly.
2. Rinse the faucet with clean water and wipe it with a soft cotton cloth.
3. Use one of the following cleaners to remove dirt from the surface:
  - a. Mild liquid cleaner.
  - b. Colorless glass cleaner and powder cleaner that do not cause abrasion and can be dissolved completely.
  - c. Polish liquid that does not cause abrasion.

### Don'ts

- a. Avoid using cleaning powder, harsh cleaning chemicals, brushes and coarse cloth to prevent scratching and friction.
- b. Do not use acid cleaners to clean the faucet as they may cause surface corrosion of the faucet. If the faucet is exposed to harmful acid substances, please rinse it immediately with water.

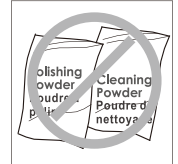
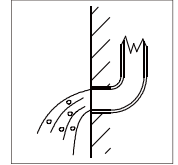
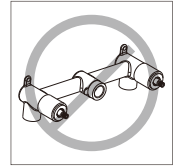

## TOOLS NEEDED:

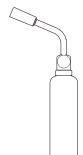
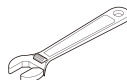
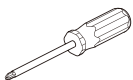

◆ **Concealed hot and cold bathtub faucet**

**Model:A**

**Accessories List**

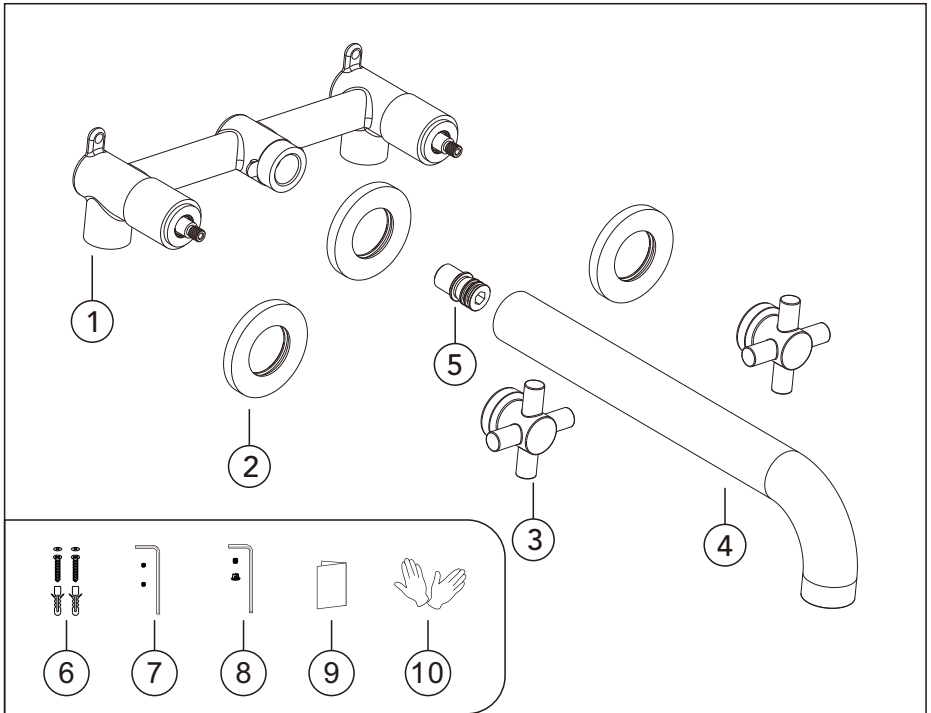

No.	Part name	Qty	No.	Part name	Qty
1	Rough-in Valve	1	6	Main body spare parts	1set
2	Flange	3	7	Connector fixing screw	1set
3	Handle	2	8	Handle parts	1set
4	Bathtub Spout	1	9	Instruction manual	1
5	Water outlet connector	1	10	Gloves	1pair

## ◆ Water circuit diagram of bathtub set

Unit: mm/inch

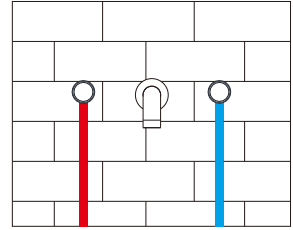

Hot water inlet Cold water inlet

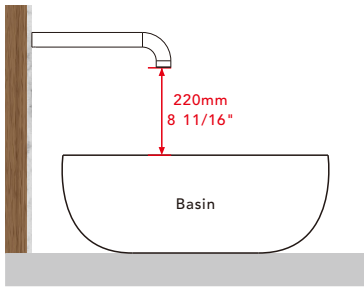

## ◆ Embedding depth of the Rough-in Valve.

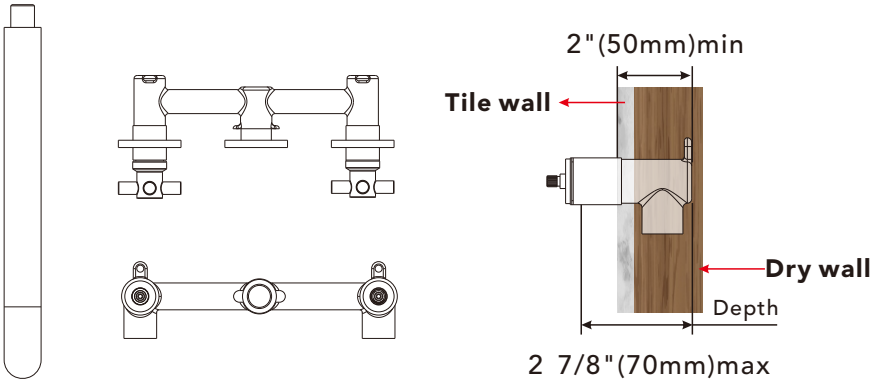

Notice: 1. The installation depth of Rough-in Valve should be no less than 2" (50mm) and no more than 2 7/8" (70mm), including the thickness of tile. Otherwise, the deck plate cannot be installed.

◆ **Installation of the Rough-in Valve(concrete wall).**

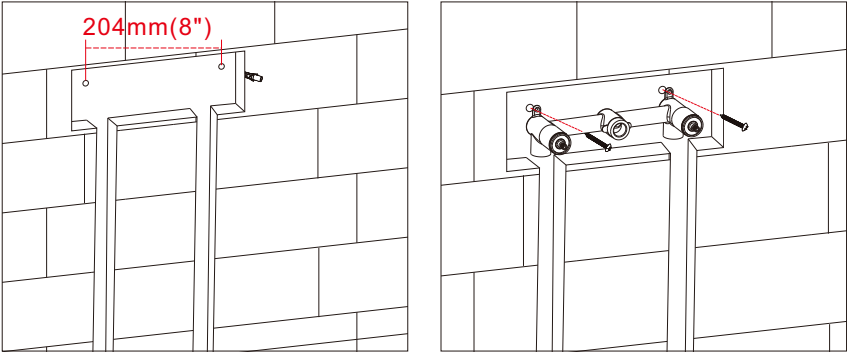

- Step 1: Measure and mark the installation points based on the dimensions of the rough-in valve. Drill holes into the concrete wall at the marked locations and insert the wall anchors.
- Step 2: Secure the rough-in valve to the wall using screws inserted into the wall anchors. Connect the hot and cold water inlet pipes to their respective inlets.
- Step 3: Perform a pressure test to check for leaks at all connections. Ensure there are no leaks before proceeding to the next step.
- Step 4: Once the pressure test is complete and all connections are confirmed to be secure, seal the rough-in valve with concrete.

◆ **Installation of the Rough-in Valve(wood wall).**

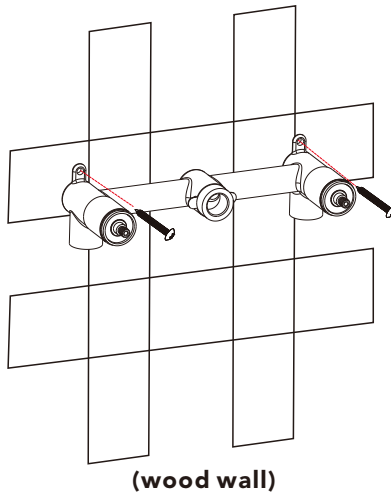

- 1:Secure the rough-in valve directly to the wooden structure using screws.

◆ **Installation of the Bathtub Faucet.**

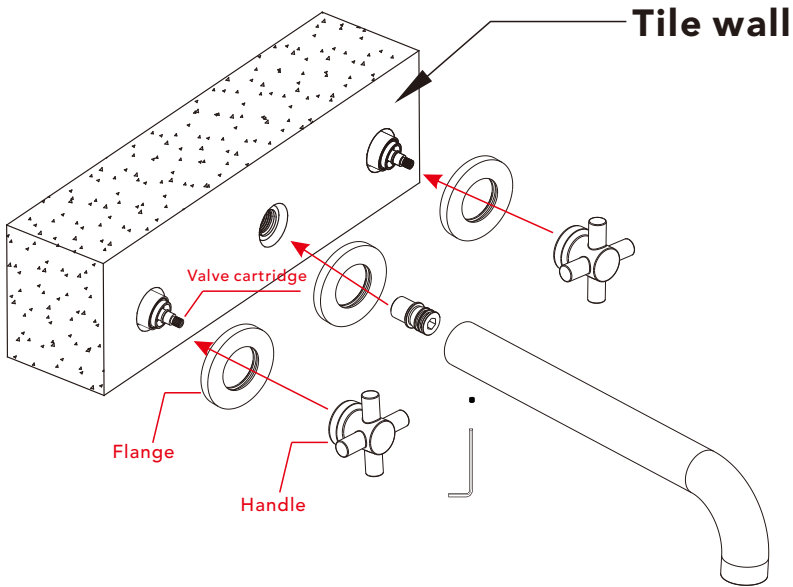

1. Attach the Flange: Screw the flange onto the brass sleeve of the rough-in valve until it is securely and evenly positioned.
2. Install the Handles: Align each handle with the valve cartridge. (Make sure the handle is securely pressed down.)
3. Connect the Water Outlet: Apply plumber's tape to the threads of the water outlet connector. Carefully screw the connector into the central outlet on the rough-in valve and ensure it is firmly secured.
4. Attach the Bathtub Spout: Align the bathtub spout with the water outlet connector and secure it by tightening the hex screw underneath. Ensure the screw hole is facing downward and the connection is tight.

## ◆ Instalación y cuestiones de mantenimiento

1. Verifique la lista de accesorios para comprobar que todas las partes están completas en este paquete.
2. No desmonte el cuerpo principal por sí mismo.
3. Conecte las tuberías de entrada a las válvulas de suministro.
4. Asegúrese de que las tuberías de entrada y las válvulas de suministro no tengan impurezas y estén limpias, sin impurezas en la tubería.
5. Después de la instalación, verifique todas las uniones para detectar fugas.
6. No deje el sistema de ducha tipo lluvia expuesto a un ambiente severamente corrosivo.

### Hacer

1. En para mantener la superficie de la batidora brillante, limpie el mezclador regularmente.
2. Inse el grifo con agua limpia y límpielo con un suave ropa de algodón.
3. Utilice uno de los siguientes limpiadores para eliminar la suciedad de la superficie: a. Limpiador líquido suave. b. Limpiador de vidrio incoloro y limpiador en polvo que no causen abrasión y que se puedan disolver completamente. c. Líquido pulidor que no cause abrasión.

### No es decir

- A. Valte con polvo de limpieza, productos químicos de limpieza duros, cepillos y tela gruesa para evitar rasgar y fricción.
- B. No use limpiadores de ácidos para limpiar el grifo, ya que pueden causar corrosión superficial del grifo. Si el grifo está expuesto a sustancias ácidas dañinas, enjuague inmediatamente con agua.

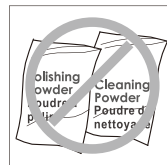
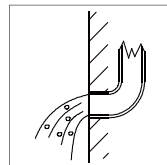
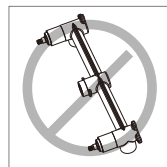

## HERRAMIENTAS NECESARIAS:

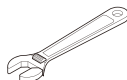
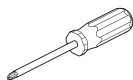

## ◆ Grifo de bañera oculto de agua caliente y fría

Modelo:A

### Lista de accesorios

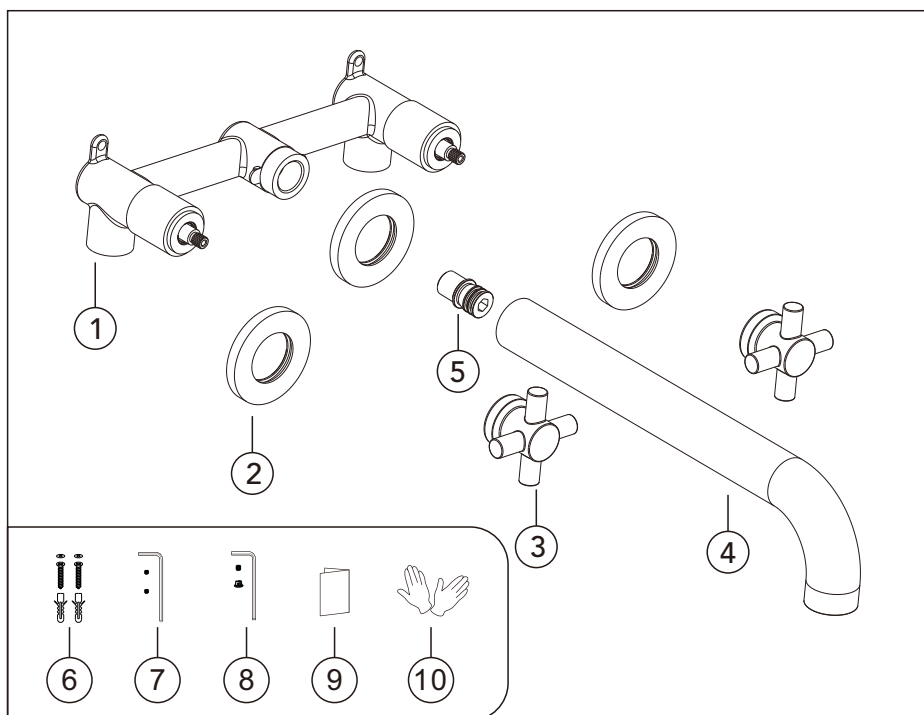

N.º	Nombre de la pieza	Cant	N.º	Nombre de la pieza	Cant
1	Válvula de Preinstalación	1	6	Piezas de repuesto del cuerpo principal	1 juego
2	Brida	3	7	Tornillo de fijación del conector	1 juego
3	Manija	2	8	Partes de la manija	1 juego
4	Caño de bañera	1	9	Manual de instrucciones	1
5	Conector de salida de agua	1	10	Guantes	1 par

## ◆ Diagrama de la altura de instalación del caño

Unidad: mm/pulgada

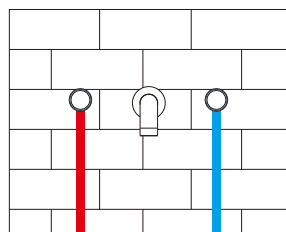

Entrada de agua caliente      Entrada de agua fría

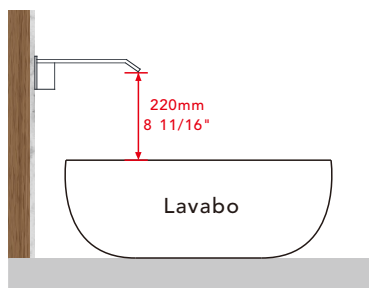

## ◆ Profundidad de empotramiento del cuerpo oculto

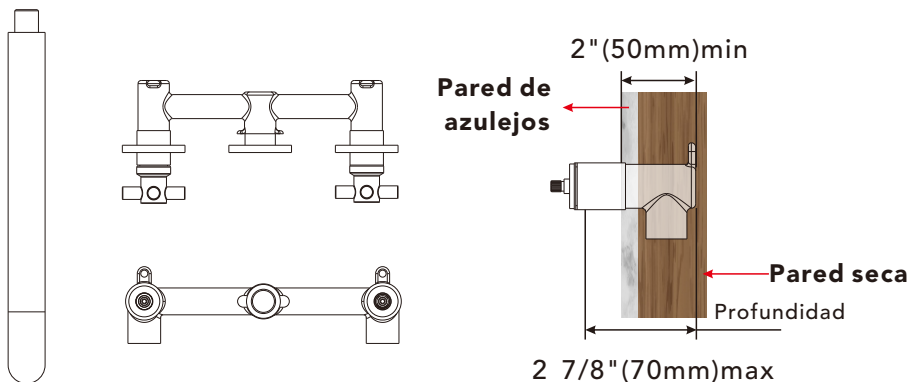

Aviso: 1. La profundidad de instalación de la válvula de preinstalación debe ser no menor a 2" (50 mm) y no mayor a 2 7/8" (70 mm), incluyendo el grosor del azulejo. De lo contrario, no se podrá instalar la placa base.

### ◆ Instalación de la Válvula de Preinstalación (pared de concreto).

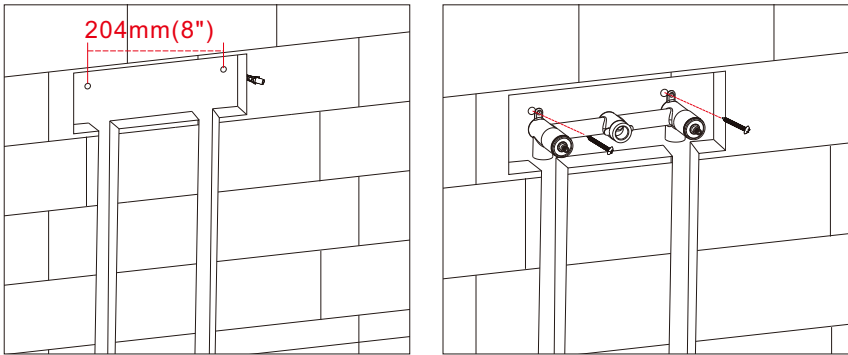

- Paso 1: Mida y marque los puntos de instalación según las dimensiones de la válvula de preinstalación. Perfore agujeros en la pared de concreto en las ubicaciones marcadas e inserte los anclajes de pared.
- Paso 2: Fije la válvula de preinstalación a la pared utilizando tornillos insertados en los anclajes de pared. Conecte las tuberías de entrada de agua caliente y fría a sus respectivas entradas.
- Paso 3: Realice una prueba de presión para verificar si hay fugas en todas las conexiones. Asegúrese de que no haya fugas antes de proceder al siguiente paso.
- Paso 4: Una vez completada la prueba de presión y confirmadas todas las conexiones como seguras, selle la válvula de preinstalación con concreto.

### ◆ Instalación de la Válvula de Preinstalación (pared de madera).

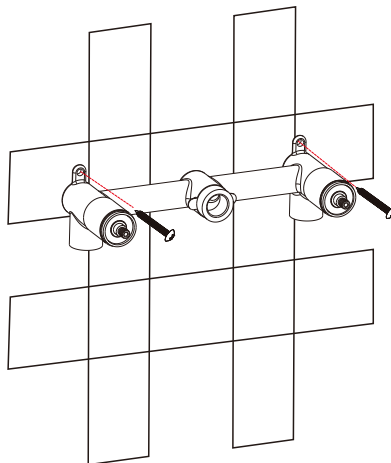

(Pared de madera)

- 1: Fije la válvula de preinstalación directamente a la estructura de madera utilizando tornillos.

## ◆ Instalación del Grifo de la Bañera.

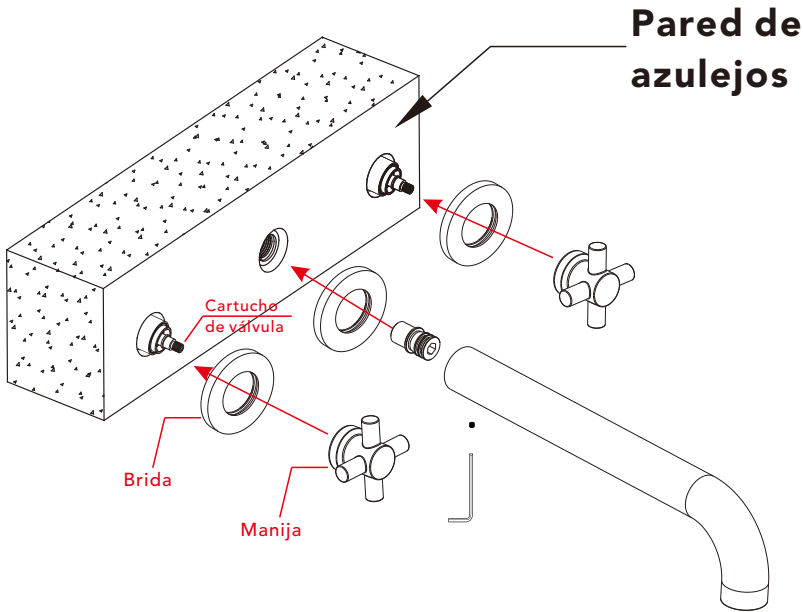

1. Fije la Brida: Atornille la brida en la manga de latón de la válvula de preinstalación hasta que esté firmemente y uniformemente posicionada.
2. Instalación de las manijas: Alinee cada manija con el cartucho de la válvula. (Asegúrese de presionar la manija firmemente hasta que quede bien fijada).
3. Conecte la Salida de Agua: Aplique cinta de plomero a las roscas del conector de salida de agua. Enrosque cuidadosamente el conector en la salida central de la válvula de preinstalación y asegúrese de que quede firmemente asegurado.
4. Fije el Surtidor de la Bañera: Alinee el surtidor de la bañera con el conector de salida de agua y asegúrelo apretando el tornillo hexagonal ubicado debajo. Asegúrese de que el orificio para el tornillo esté hacia abajo y que la conexión sea firme.