

Roll flashing is used for custom flashing and do-it-yourself projects. Roll flashing adds a professional customized look to any dormer or flashing piece. Available in a variety of widths and lengths, in aluminum, steel and copper.

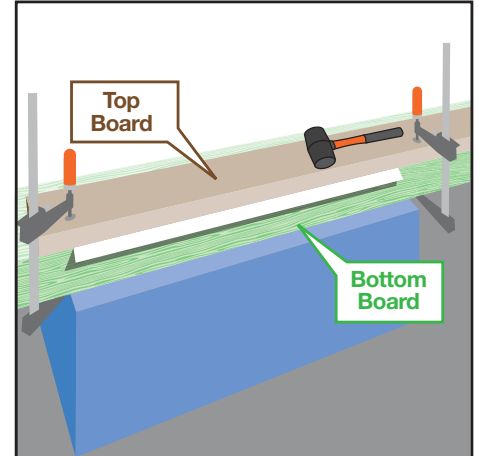
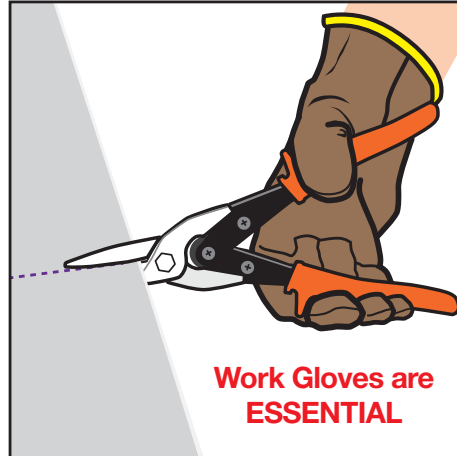
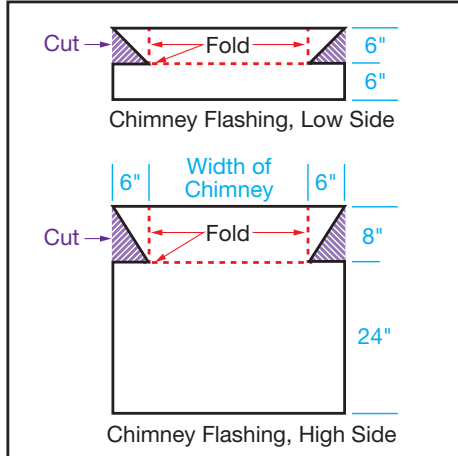

MEASURE

Carefully measure and mark where flashing is to be cut and bent. Lightly scribe the fold lines with a utility knife or marking gauge.

CUT

Roll flashing can be heavily scribed, using a straight edge and utility knife, then bent until it snaps; or it can be easily cut with aviation snips. **Caution: The edges are extremely sharp!**

BEND

Make crisp bends with a professional brake, or clamp the flashing material between two straight edged wooden blocks. Refine the edges with a rubber mallet.

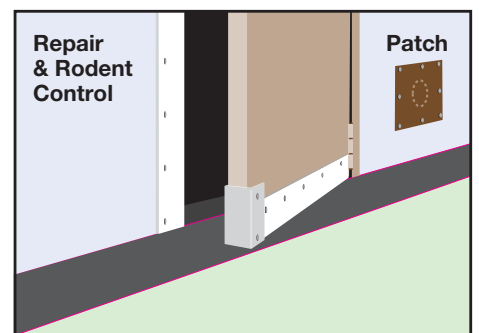
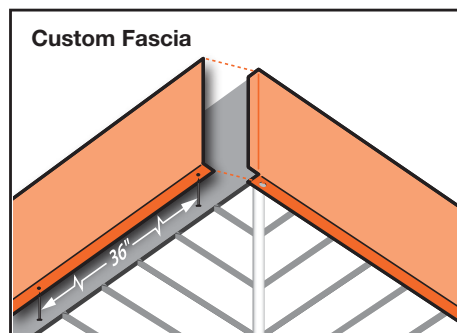
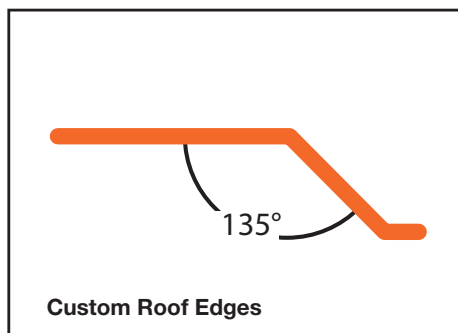
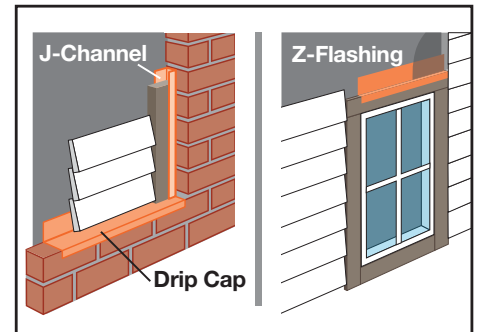
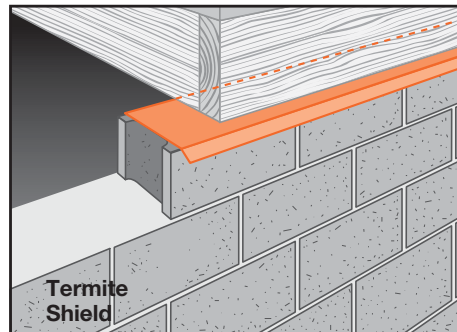
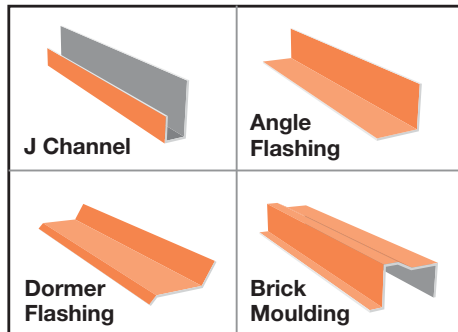

These installation guidelines are for use with typical or standard applications. It is always recommended to seek advice from a licensed professional, and to check with your local building inspector or building permit office for approvals and possible variations that may apply.