

# User's Manual





# INSTALLATION STEPS

This product has been inspected and debugged by the factory to the best condition. Please do not disassemble and assemble it yourself.



Before installing the faucet, please be sure to remove sundries and sludge from the water pipe to prevent sundries from blocking the faucet.

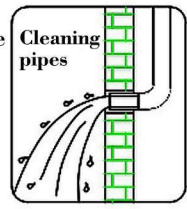

1

Mark the position of the screw holes on the wall, drill holes and install the main body.

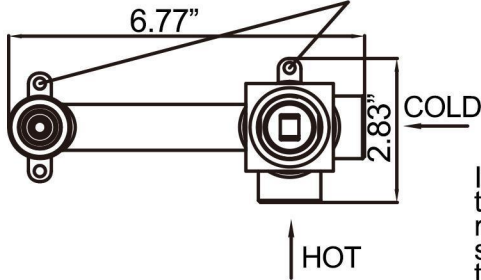

In the process of burying the wall, please do not remove the protective sleeve to avoid bumping the copper sleeve.

The inner wall is flush with the plane of the main body.

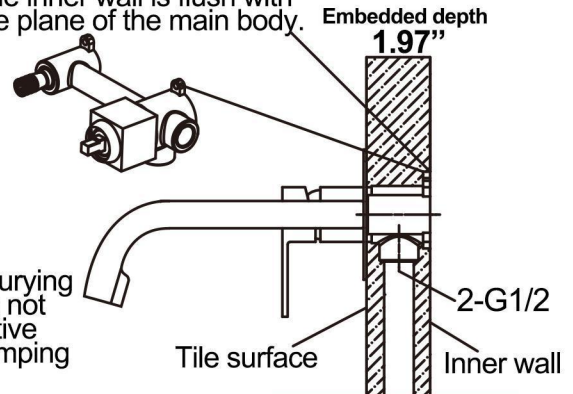

2

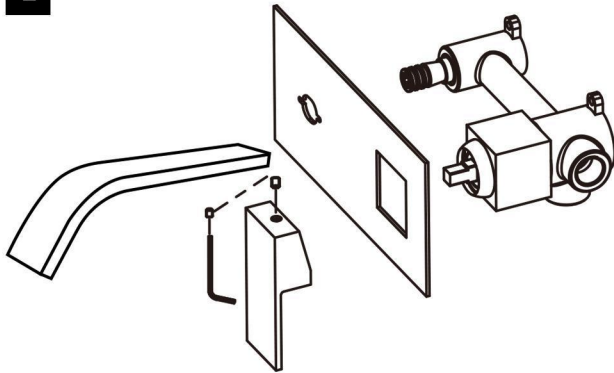

After the main body is buried in the wall, install it in the order shown in the following figure:

1. Remove the protective cover.
2. Cover the panel.
3. Install the handle and the water outlet connector.

## ► Installation Dimension

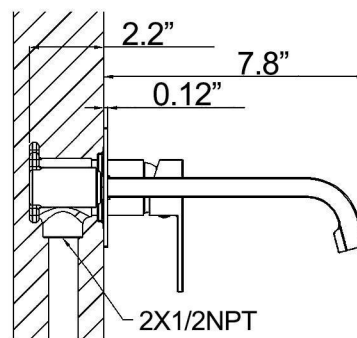
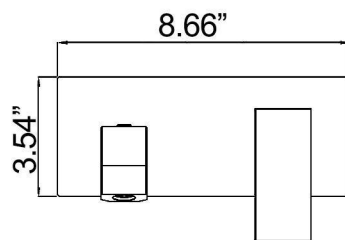

## CLEANING CARE

In order to keep the appearance of faucet clean, bright and good performance, please take care of the faucet as follows;

1. Rinse with water only and dry with soft cotton cloth;
2. Use mild liquid and colorless glass cleaner to remove surface dirt and scale film, or use polish without abrasive effect;
3. Do not use abrasive detergent, polish, emery cloth, paper towel or scraper, etc.;
4. Do not use acid cleaner, or cleaner and soap with insoluble gran etc.;
5. In the process of use, mud may accumulate in the bubbler and make the water flow show, The bubbler can be unscrewed, rinsed with water, and then installed back in place.



