

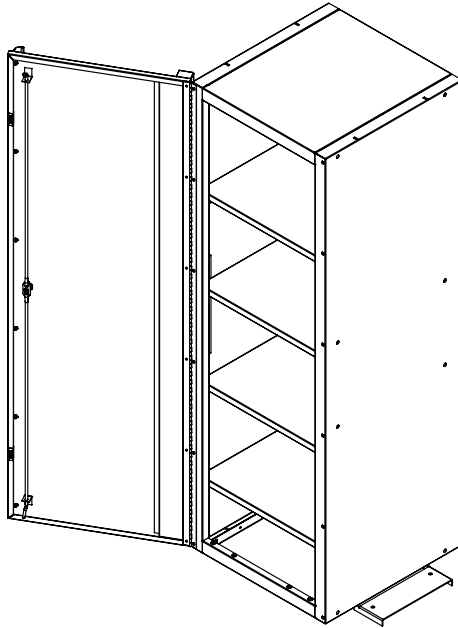

**DX Series
Powder Coated Steel
19in W x 25in D Side Locker with 4 Shelves**



Model: DX192100SL

Extreme Tools, Inc.
740 Frontenac Road
Naperville, Illinois 60563
630.369.9303

CustomerService@extremetools.net
www.ExtremeTools.com

DX192100SL Parts List

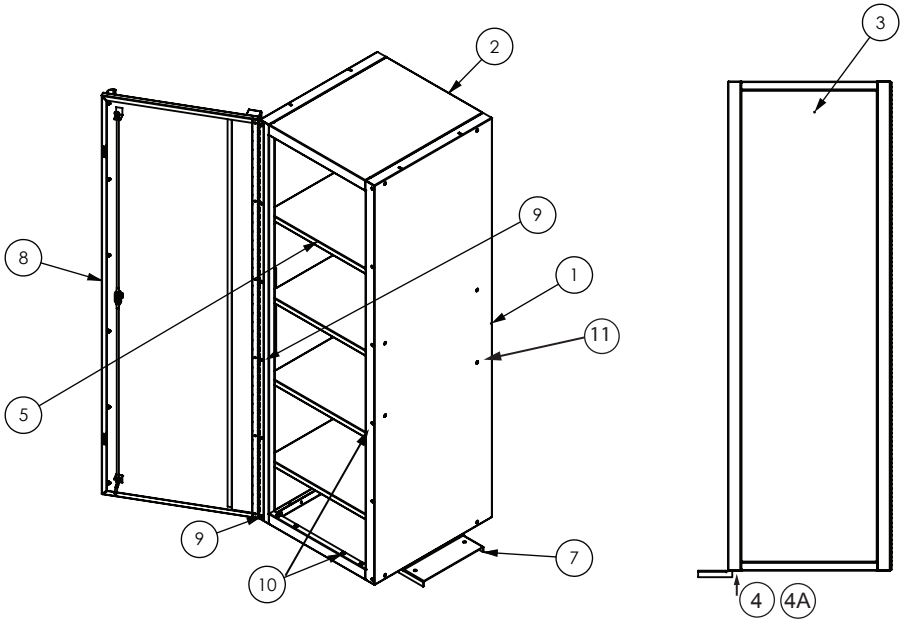

ITEM NO.	PART NUMBER	DESCRIPTION	QTY
1	DX192104SL-02	SIDE PANEL ASSEMBLY	2
2	DX192104SL-06	TOP/BOTTOM PANEL	2
3	DX192104SL-01	BACK PANEL	1
4	Z-M8X16HBS	M8 X 16mm HEX BOLT	6
4A	Z-FWM8	M8 FLAT WASHER	6
5	DX192104SL-07	ADJUSTABLE SHELF	4
6	Z-SCLIP-METAL	SHELF CLIP	8
7	DX192104SL-18	SUPPORT MOUNTING BRACKET	1
8	DX192104SL-08	DOOR ASSEMBLY	1
9	91420A218	M4-.07 X 8mm FLAT HEAD SCREWS	11
10	Z-M4X6MS	M4 X 6 MACHINE SCREWS	36

Step1:

Place packing material or other soft surface down and lay back panel on soft surface.

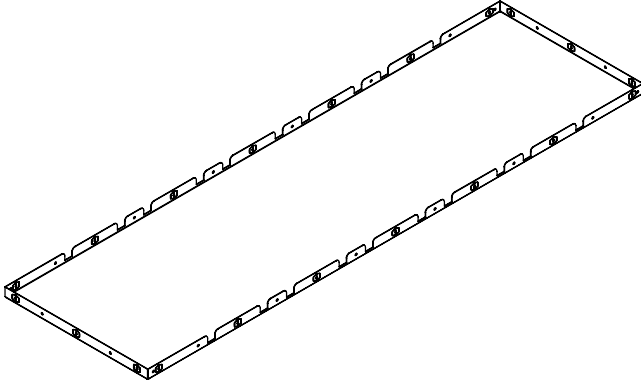

Step 2:

Position one side panel assembly perpendicular to the back panel.

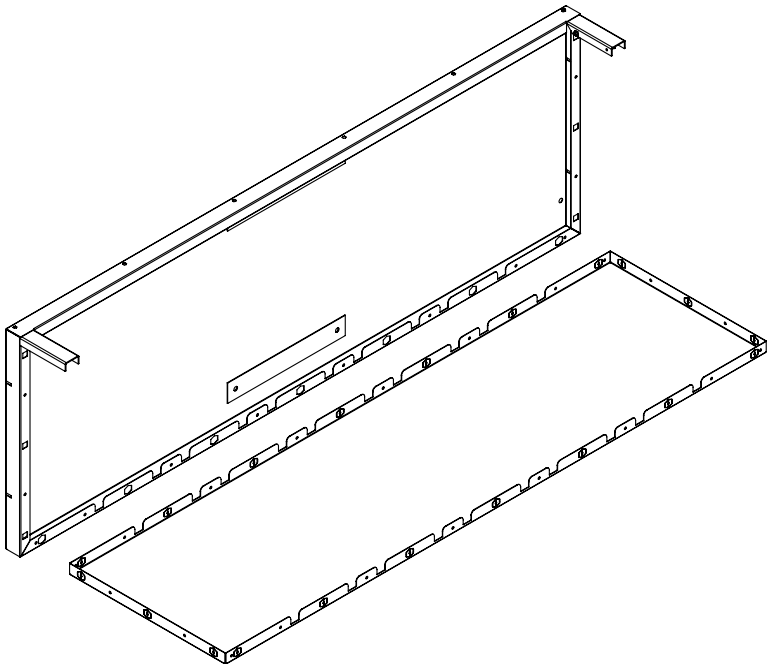

Step 3: Align holes and secure side panel using the pre-threaded inserts and (8) M4 machine screws.

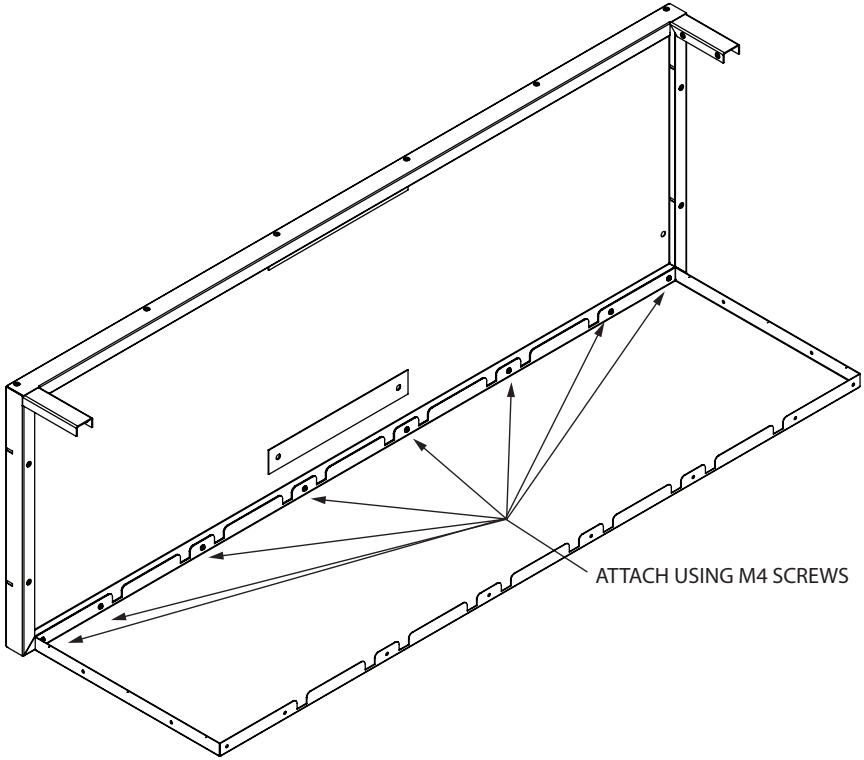

Step 4:
Slide top/bottom panels through the slots and onto the gussets of the side panel.

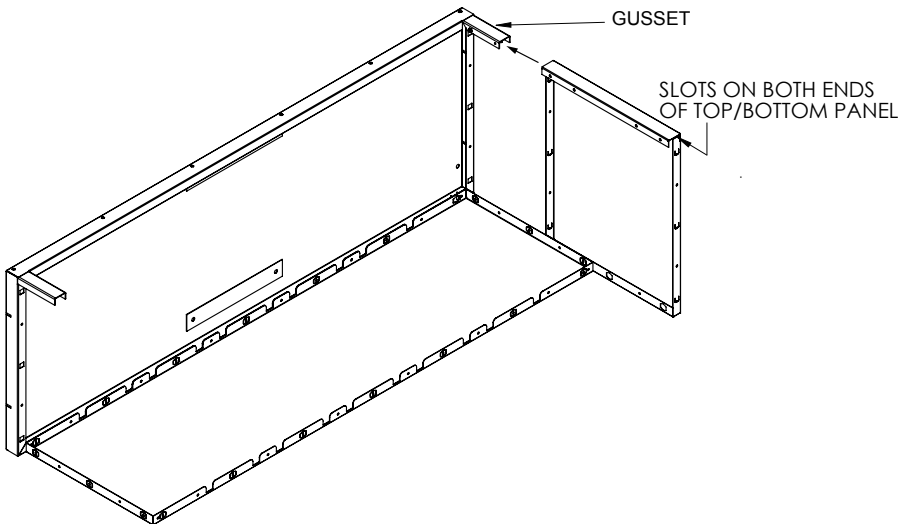

Step 5:

Secure top panel to side and back panels using (4) M4 x 6 screws through pre-threaded inserts and into gussets.

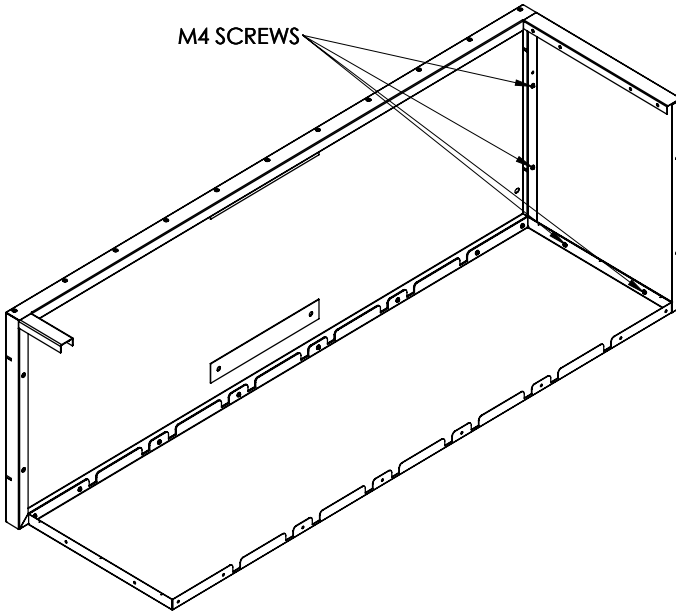

Step 6:

Repeat Step 5 to add the other top/bottom panel.

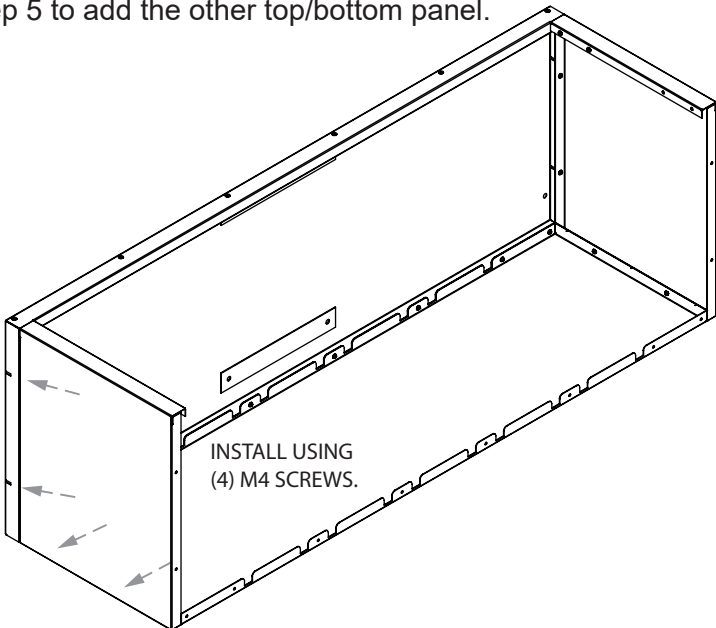

Step 7:

Add the other side panel assembly by inserting the attached gussets of the side panel through the slots of the top and bottom panels.

Attach the side panel to back panel and top and bottom panels by inserting and securing (12) M4 x 6 screws into the pre-threaded inserts as shown.

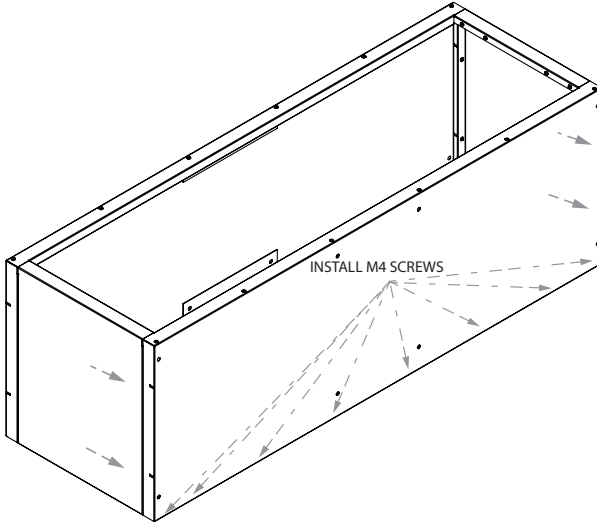

Step 8:

Locate the two Reinforcing Channels. Place a Reinforcing Channel into the Gusset in the top panel and align pre-threaded inserts of Reinforcing Channel with holes in Gusset. Secure with (2) M4 x 6 screws at each end of the Reinforcing Channel. Repeat procedure for the bottom panel.

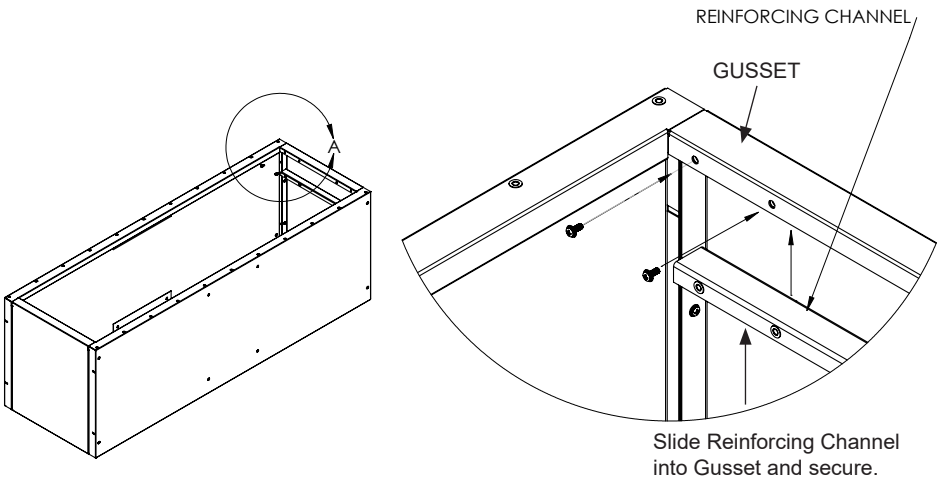

Step 9: **CAUTION! ENGAGE BRAKES ON CASTERS BEFORE PROCEEDING WITH REMAINING STEPS!**

Set the assembled side locker body upright on the floor.

Engage brakes on casters. Attach the Support Mounting Bracket on the bottom support channel of the roller cabinet with (2) M8 x 16mm Hex Bolts & Washers.

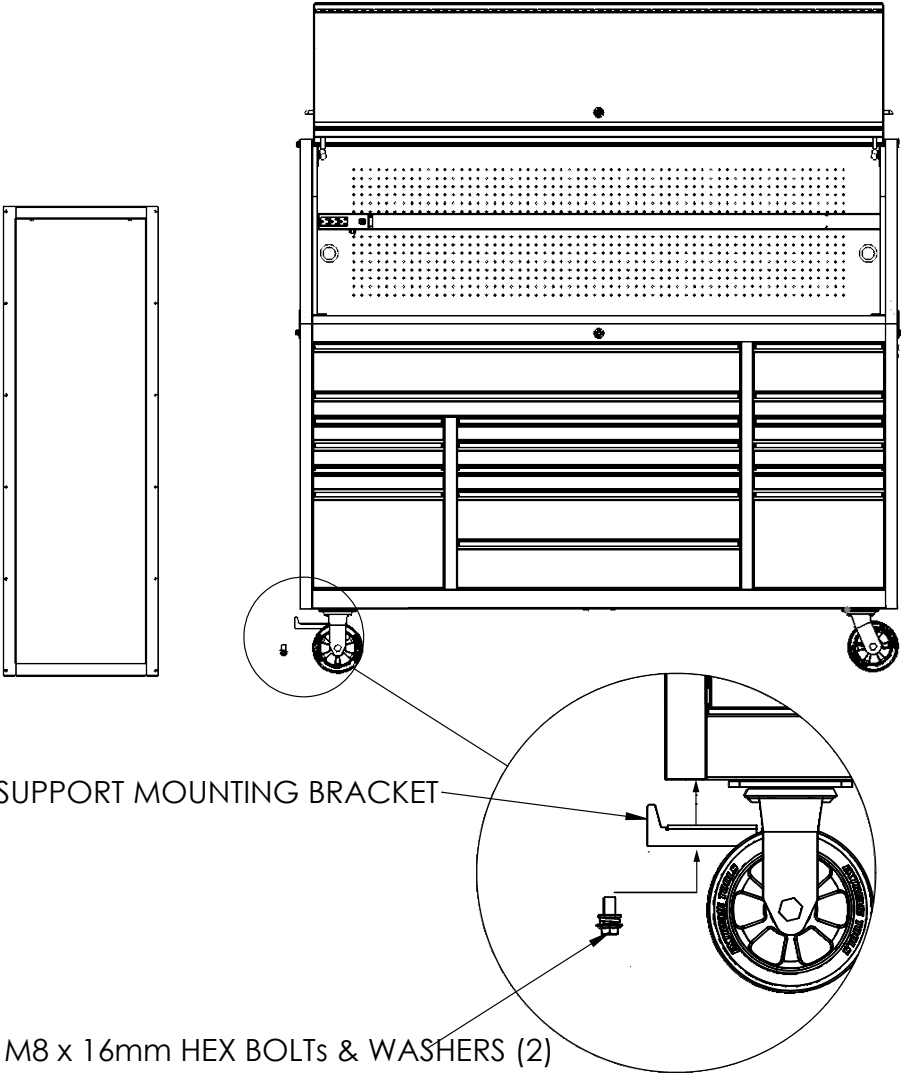

Step 10: **SIDE LOCKER IS HEAVY! AND REQUIRES ASSISTANCE TO LIFT INTO PLACE!**

Locate the slots on the bottom panel of the side locker.

WITH ASSISTANCE, lift and position the assembled side locker body onto the tabs of the support bracket. Make sure the slots on the bottom of side locker are fully engaged with the tabs of the support mounting bracket.

CONTINUE HOLDING THE SIDE CABINET IN PLACE WHILE GOING TO THE NEXT STEP!

SLOTS ON BOTTOM OF UNIT

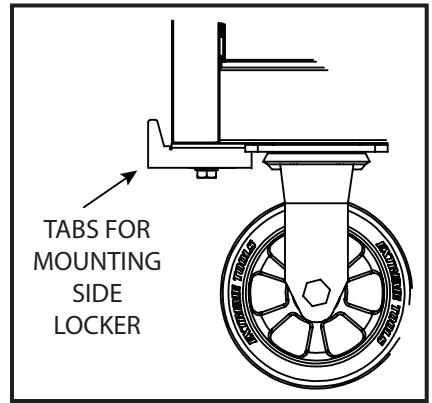

M8 x16mm HEX BOLTS & WASHERS

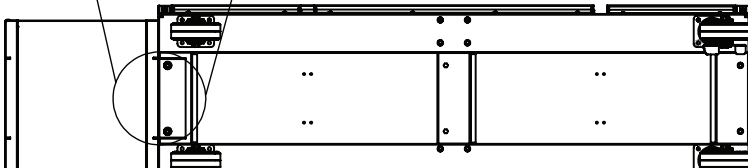

Step 11:

With the assistance of another person holding the side locker in place, secure side locker body to the roller cabinet and hutch (or chest) with (4) M8x20 Hex Bolts & (4) M8 Flat Washers.

Place (4) M8 Flat Washers onto (4) M8 x 16mm Hex Bolts and insert into pre-threaded inserts located at top and middle of side panel making sure to engage corresponding pre-threaded inserts on roller cabinet side and hutch side (or chest side.) Tighten bolts securely.

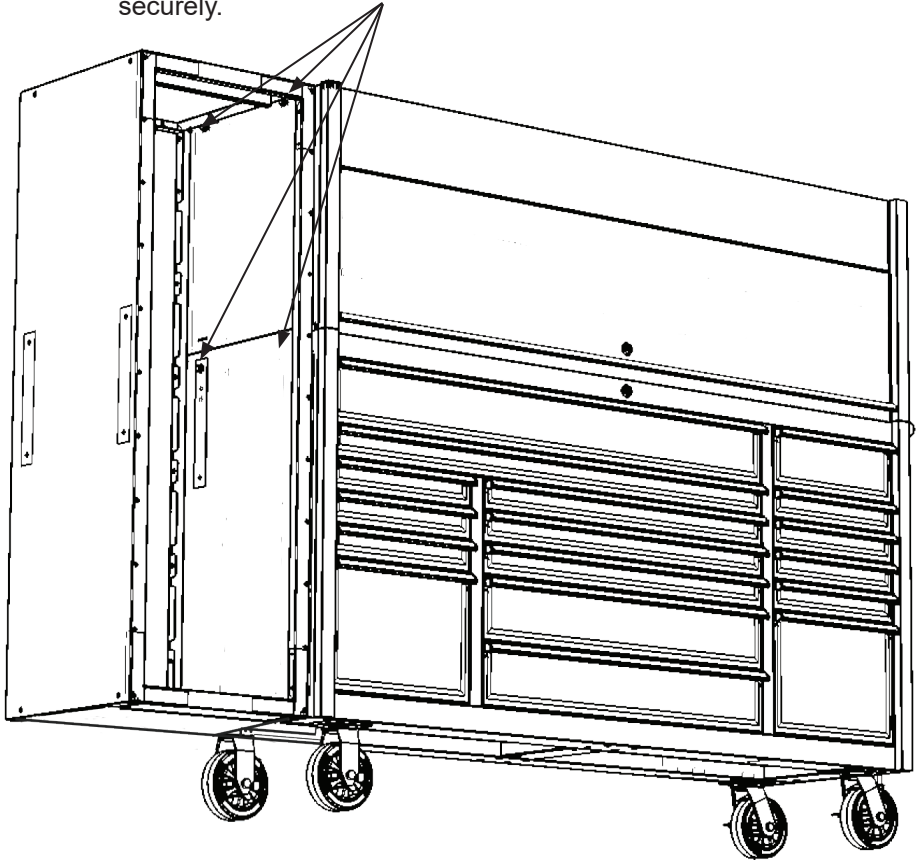

Step 11:

Install shelves in the desired positions by inserting the rear edge of each shelf into the slots of the back panel. While holding the front end of the shelf, insert the shelf clips into the slots on the side panels that are the same height as the back slots. Rest shelf on shelf clips.

Step 12:

Side locker door is HEAVY!

Use assistance to lift into place for installation!

Install the side locker door by inserting and tightening (6) M4 x 6 flat head screws into pre-threaded inserts on edge of side panel.

Install (6) M4 x 6 flat head screws into pre-threaded inserts.

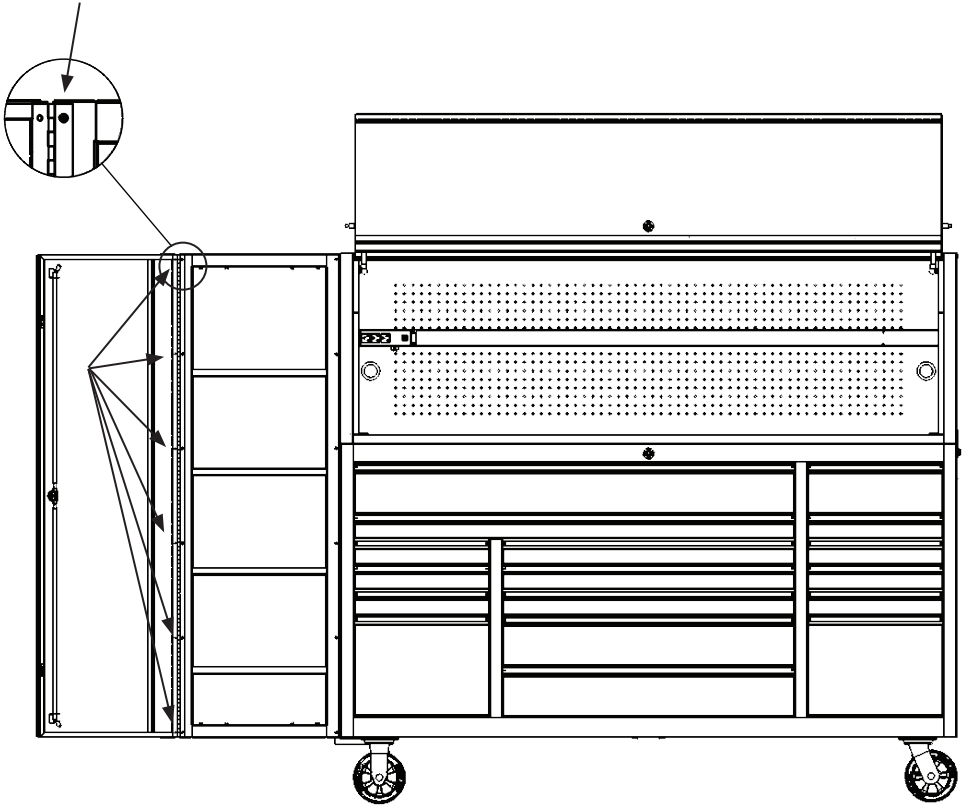

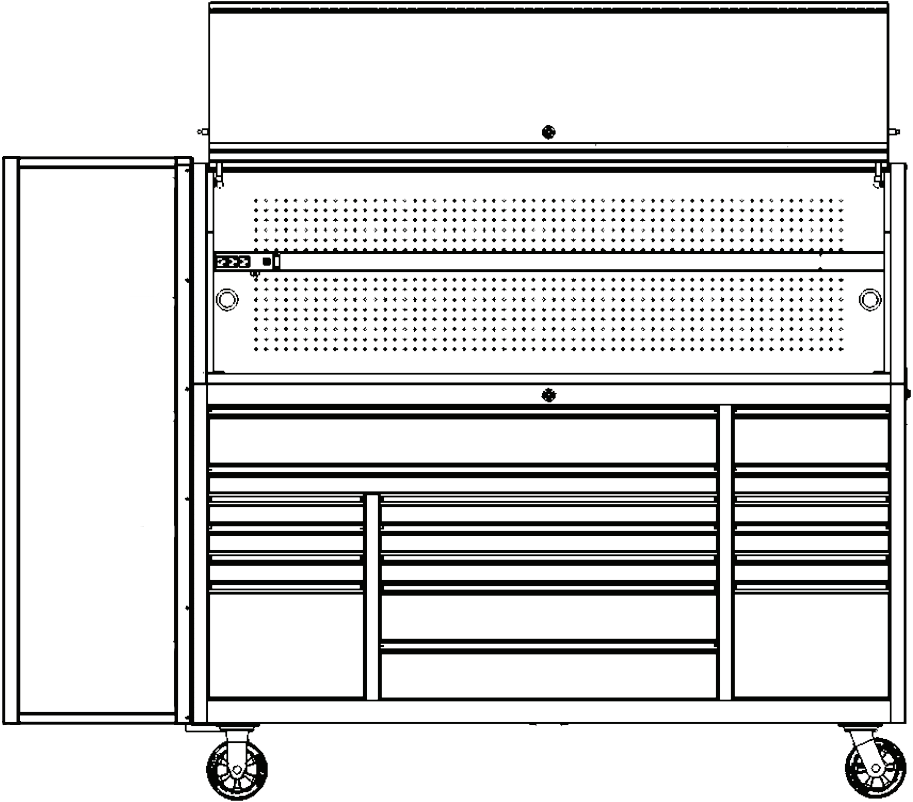

**DX192100SL DX Series 19"W x 21"D Side Locker
with 4 Adjustable Shelves**

*shown mounted on
DX722117RC 72"W x 21"D 17 Drawer Roller Cabinet &
DX722101HC 72"W x 21"D Extreme Power Workstation® Hutch*