

IMPORTANT INSTRUCTIONS AND OPERATING MANUAL

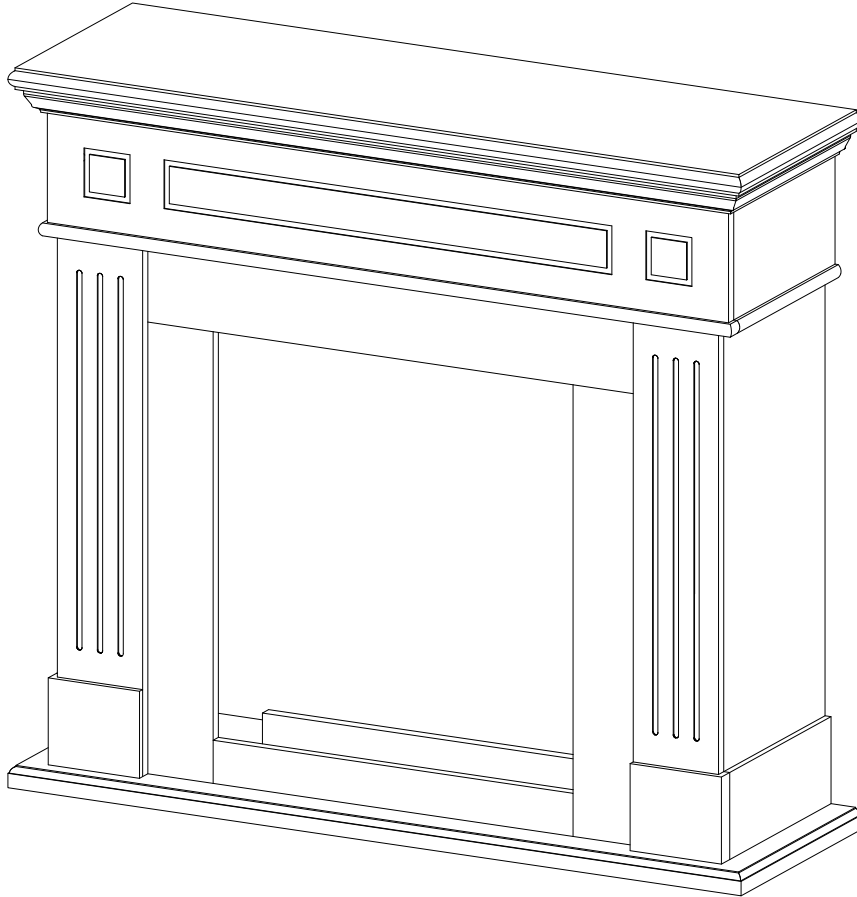

M27/M027 ELECTRIC FIREPLACE

THIS INSTRUCTION BOOKLET CONTAINS IMPORTANT SAFETY INFORMATION. PLEASE READ AND KEEP FOR FUTURE REFERENCE.

Do Not Return This Product!
Contact our customer service team for help first.
Call: 213-4467172 or 661-4358826
Monday - Sunday 8:30 am -5:30 pm P.S.T
ROWAN ELECTRIC APPLIANCE LLC
750S. Valley View Avenue, San Bernardino, CA 92408

WARNING

- Unit can tip over causing severe injury.
- Anchor unit to study on wall (if instructed to).
- Do Not allow children to climb on unit.
- Put heavy items on lower shelves or drawers.

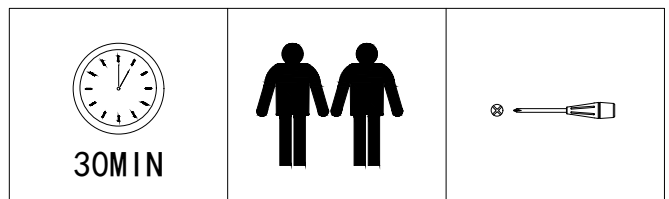

Contact Us !

DO NOT RETURN THIS PRODUCT!

Contact our friendly customer service team first for help.

Call: 213-4467172 or 661-4358826

(8:30 am - 5:30 pm P.S.T)

DATED PROOF OF PURCHASE REQUIRED FOR WARRANTY SERVICE.

[Helpful Hints]

**PEOPLE NEEDED FOR ASSEMBLY: 2
ESTIMATED ASSEMBLY TIME: 0.5 HOUR**

-Open your item in the area you plan to keep it to avoid excessive heavy lifting.



-Identify, sort and count the parts before attempting assembly.



-Make sure to always face the point on the top of the Cam Lock towards the outer edge.



-Use all the nails provided for the back panel and spread them out equally.



-Back panel must be used to make sure your unit is sturdy.



-Do NOT use harsh chemicals or abrasive cleaners on this item.

-Never push, pull, or drag your furniture.



PARTS LIST

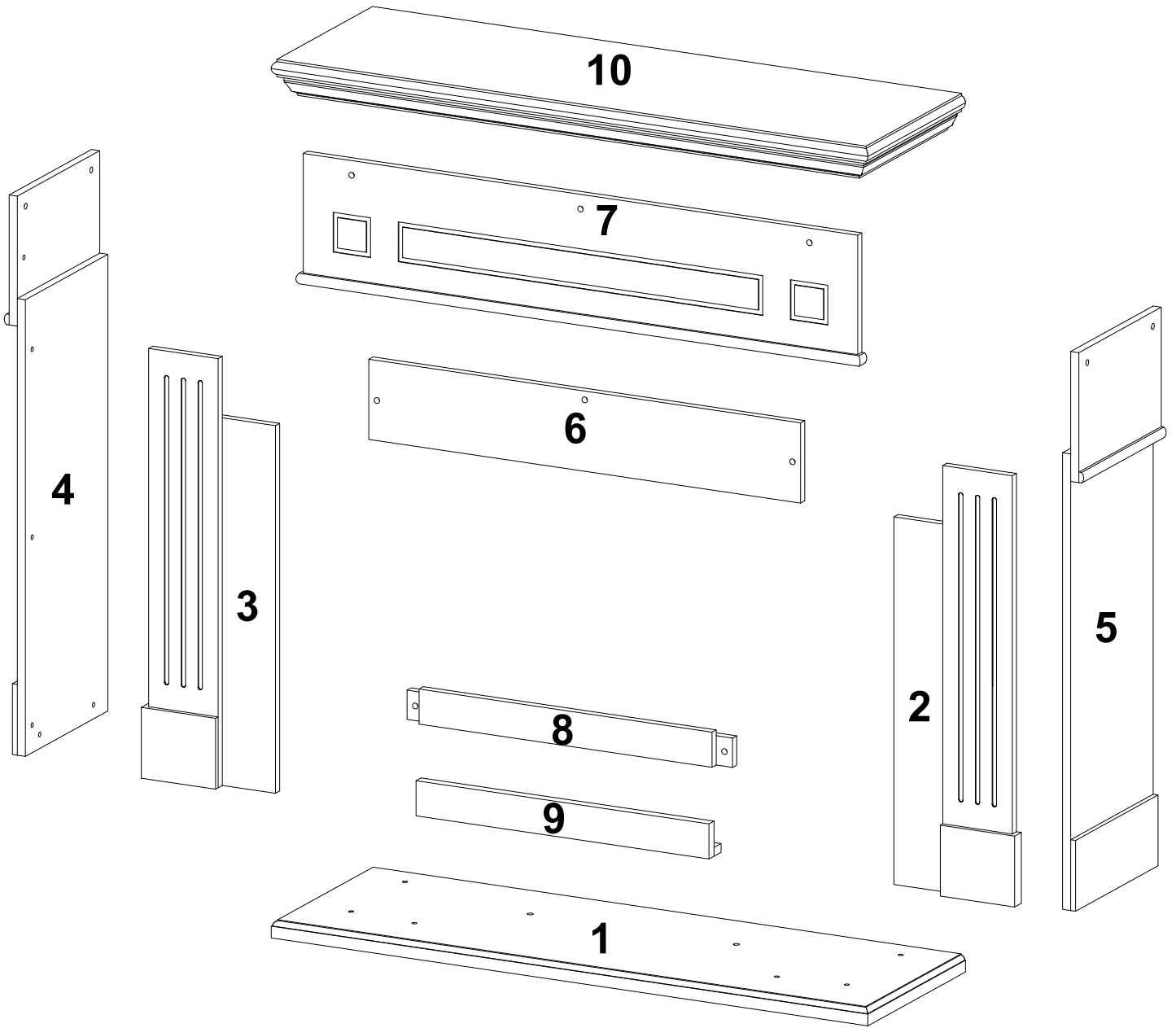

HARDWARE LIST

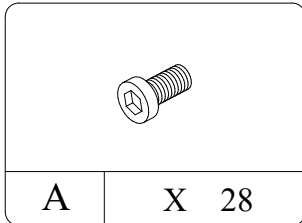

Ø6 x12mm

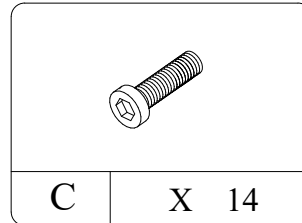
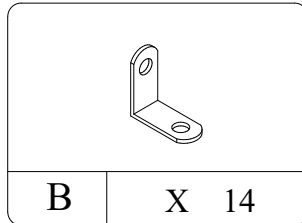

Ø6 x 28mm

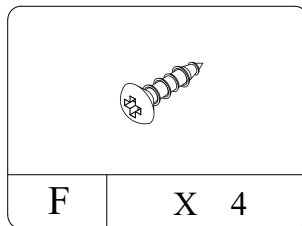
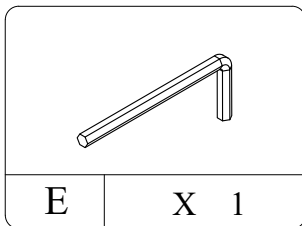
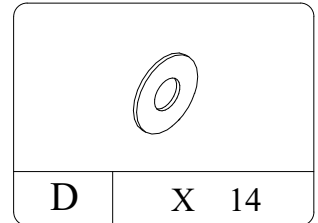

Ø4 x12.7mm

DIMENSIONS

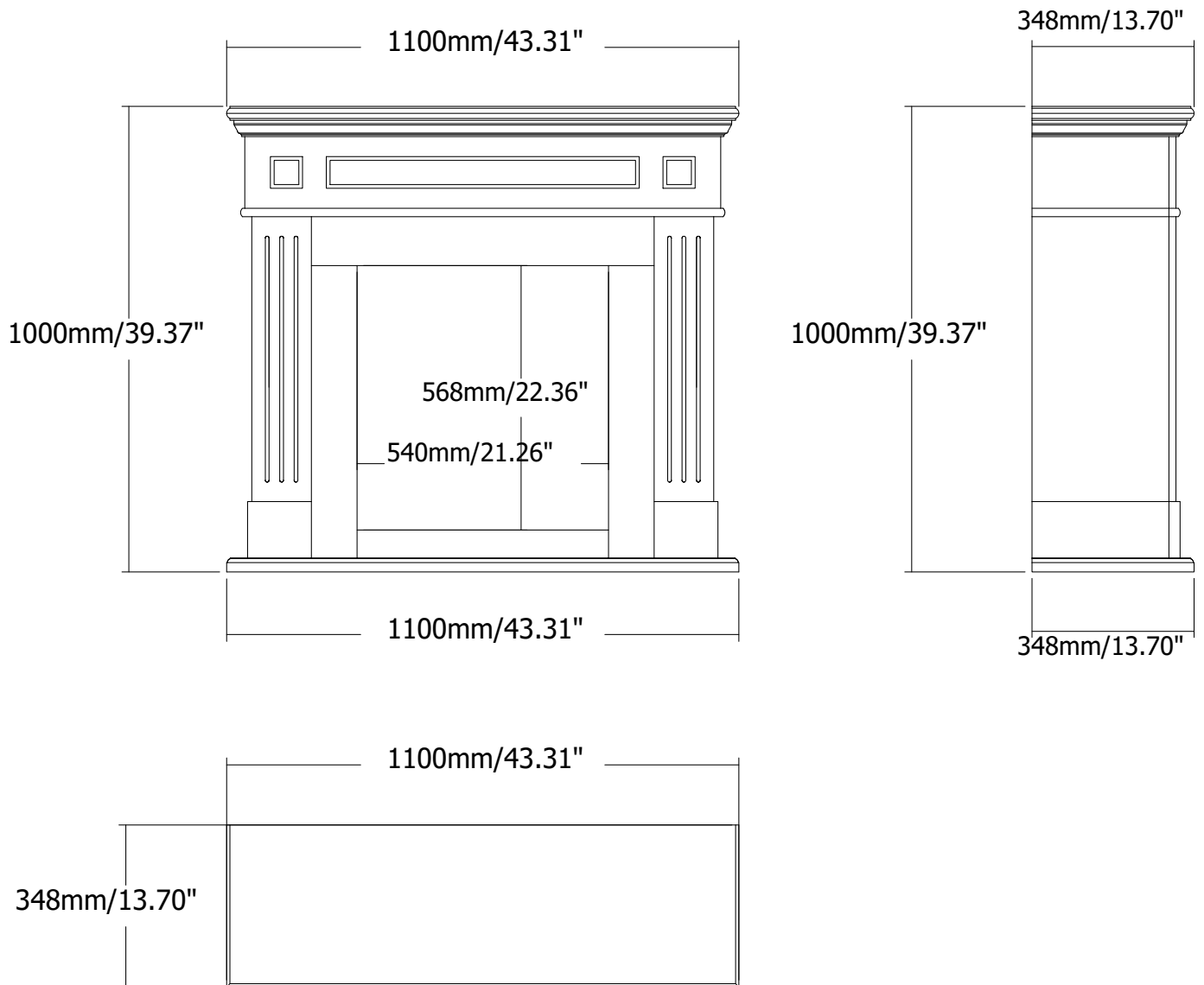

ASSEMBLY

Before installing this fireplace, please read the following steps carefully.

STEP 1:

Join panels (2)+(5), (3)+(4) by securing screws (A) via L-brackets (B) with the allen wrench (E) provided.

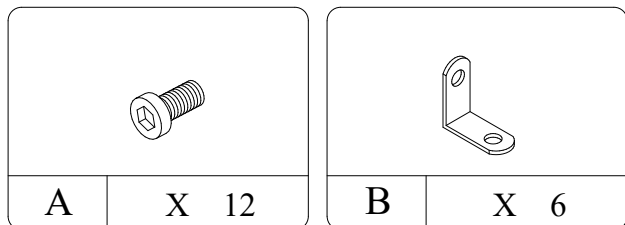

Ø6 x12mm

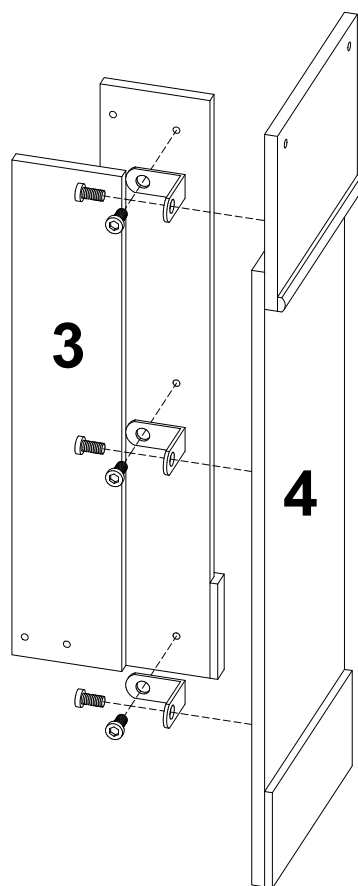
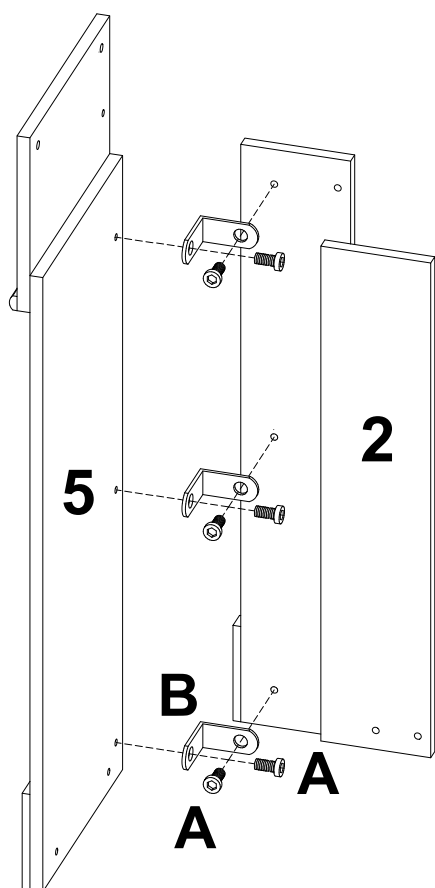

STEP 2:

Join the panel (1) by securing screws (A) via L-brackets (B) with the allen wrench (E) provided.

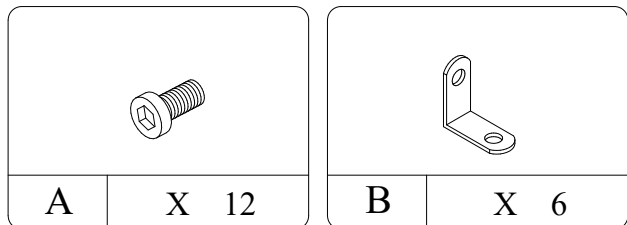

Ø6 x12mm

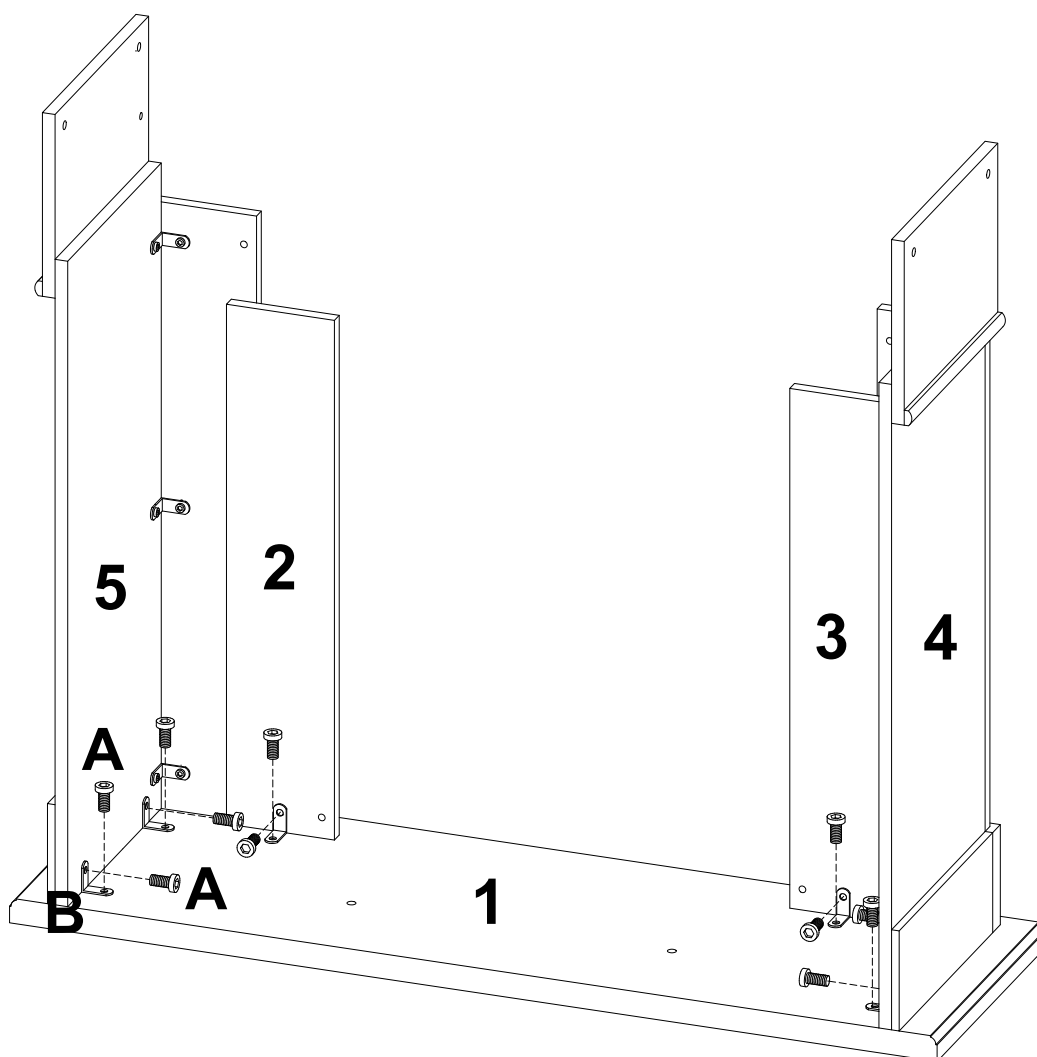

STEP 3:

Join the panel (7) by securing screws (A) via L-brackets (B) with the allen wrench (E) provided.

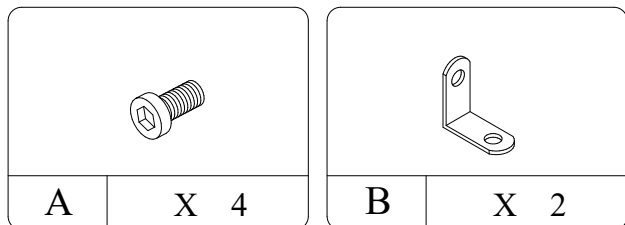

Ø6 x12mm

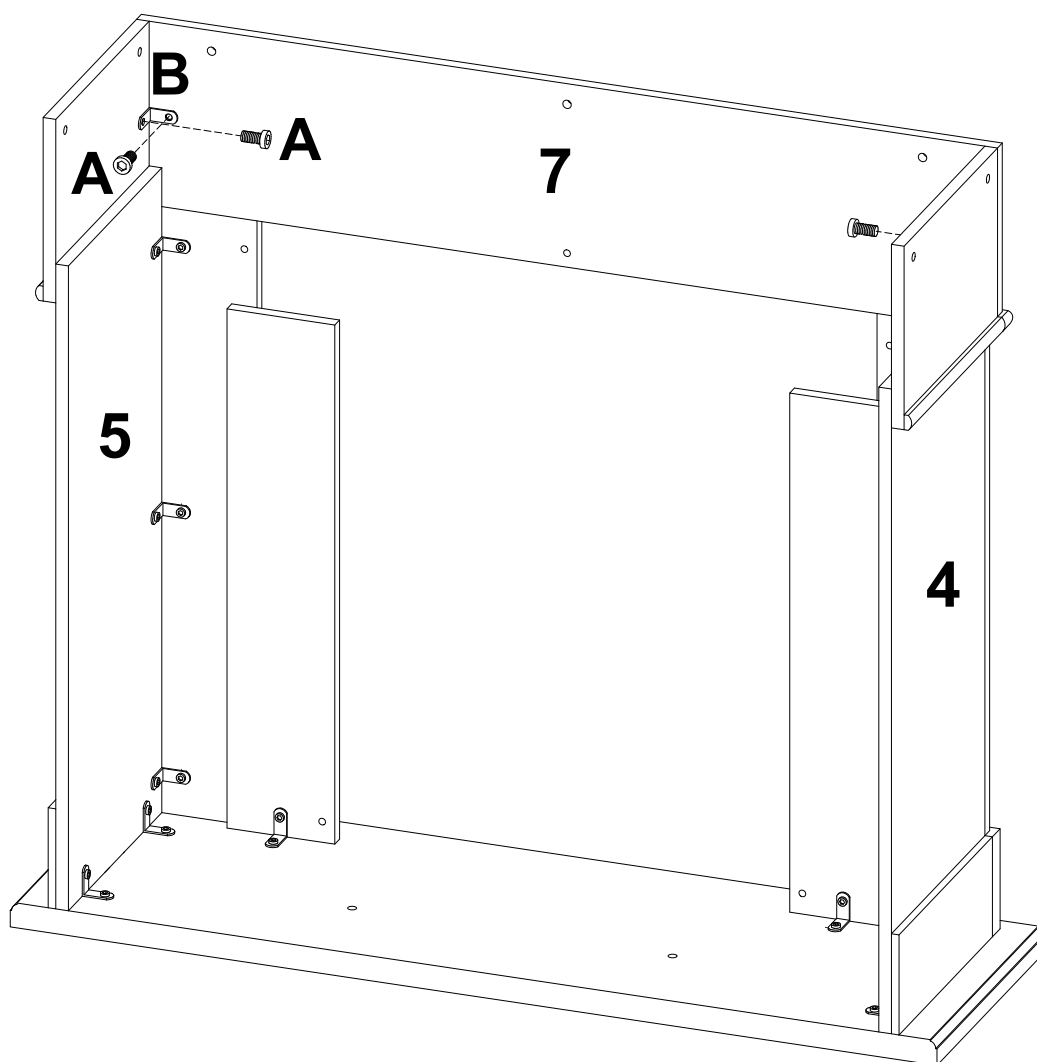

STEP 4:

Join panels (6)+(8) by securing screws (C) via washers (D) with the allen wrench (E) provided.

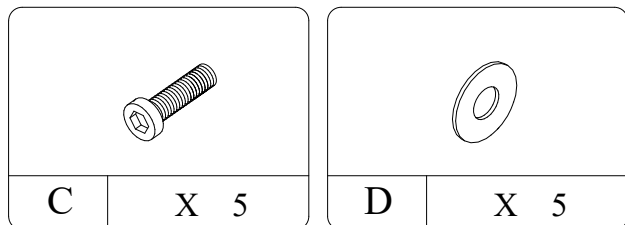

Ø6 x 28mm

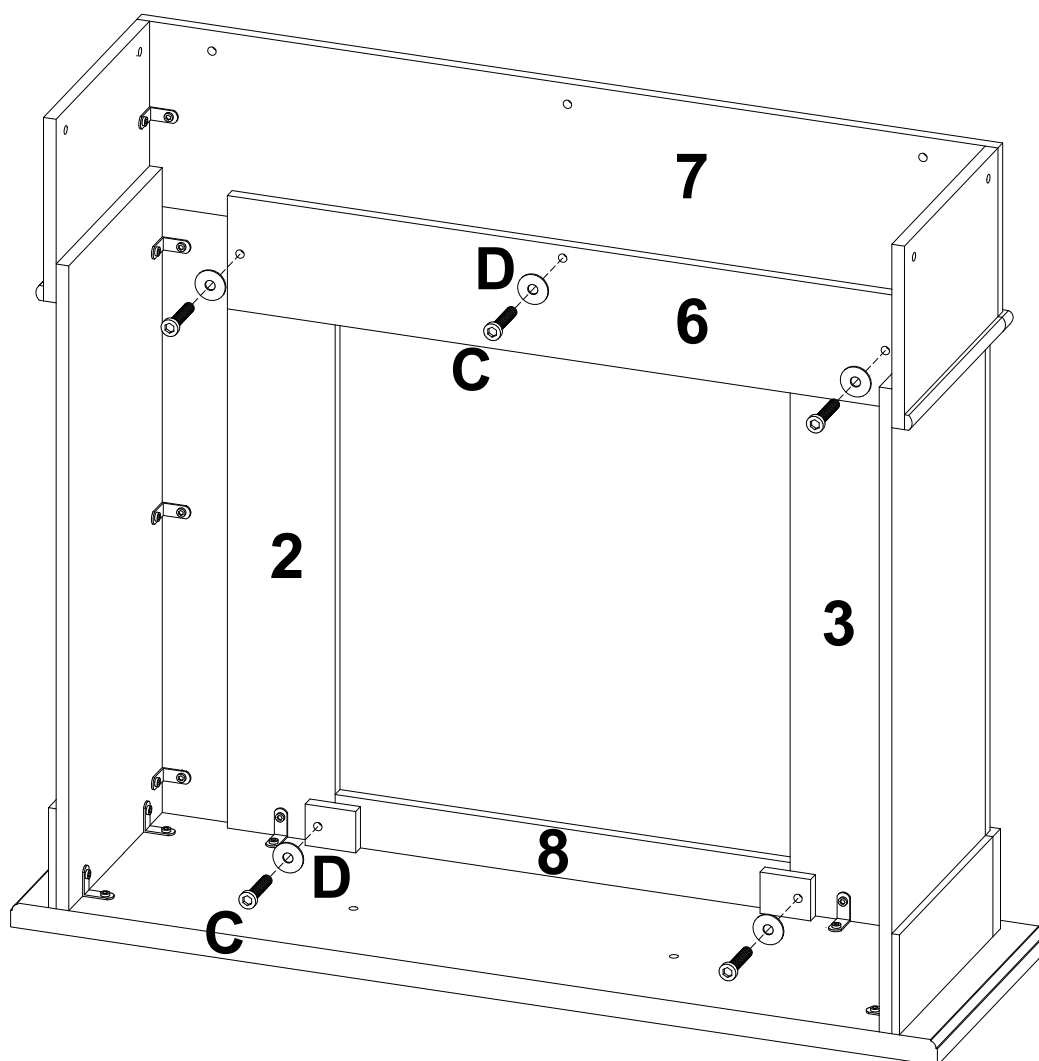

STEP 5:

Join the panel (10) by securing screws (C) via washers (D) with the allen wrench (E) provided. Join the panel (9) by inserting it along the slots on panels (4)+(5).

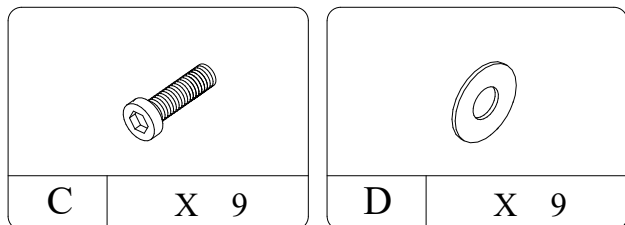

Ø6 x 28mm

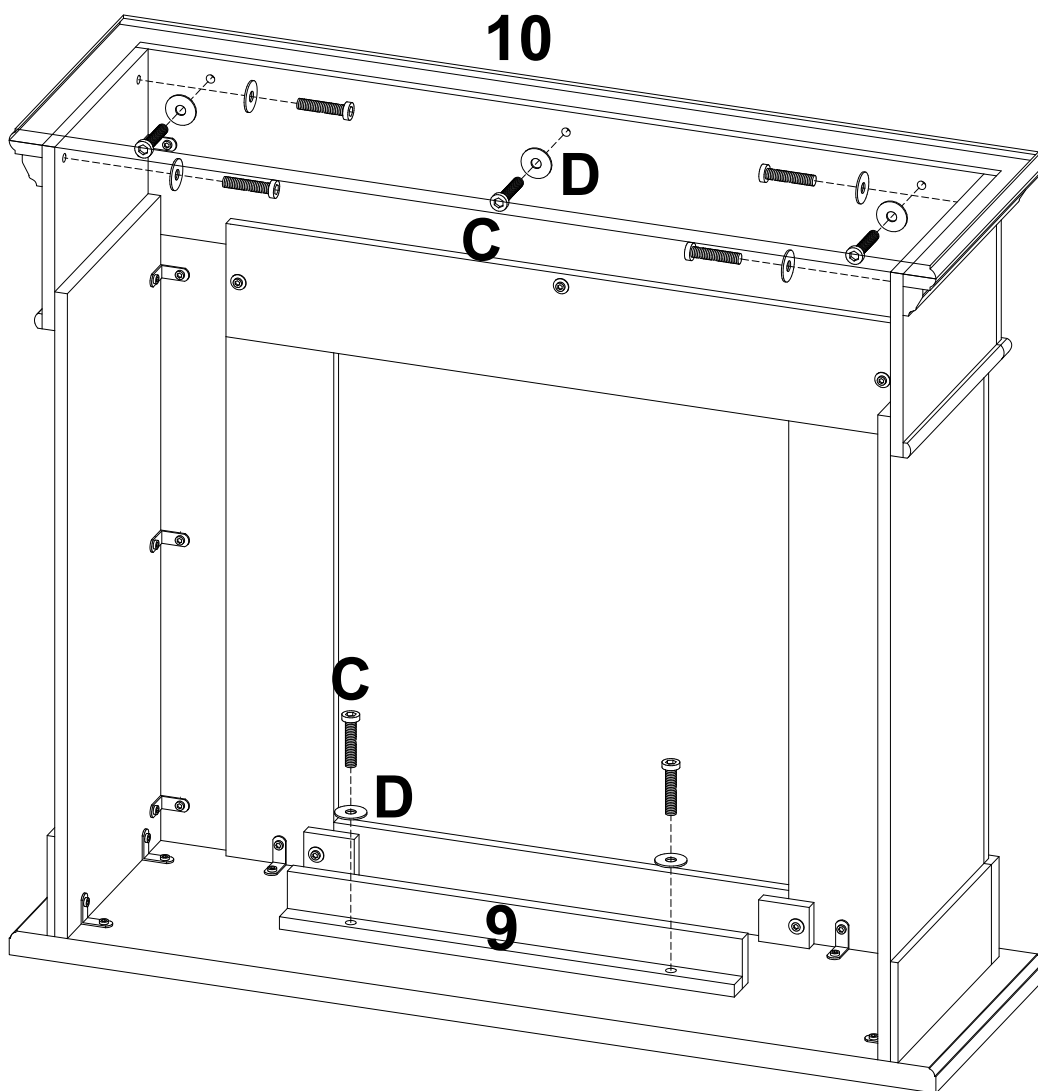

STEP 6:

Install the firebox by securing screws (F).



F X 4

Ø4 x12.7mm

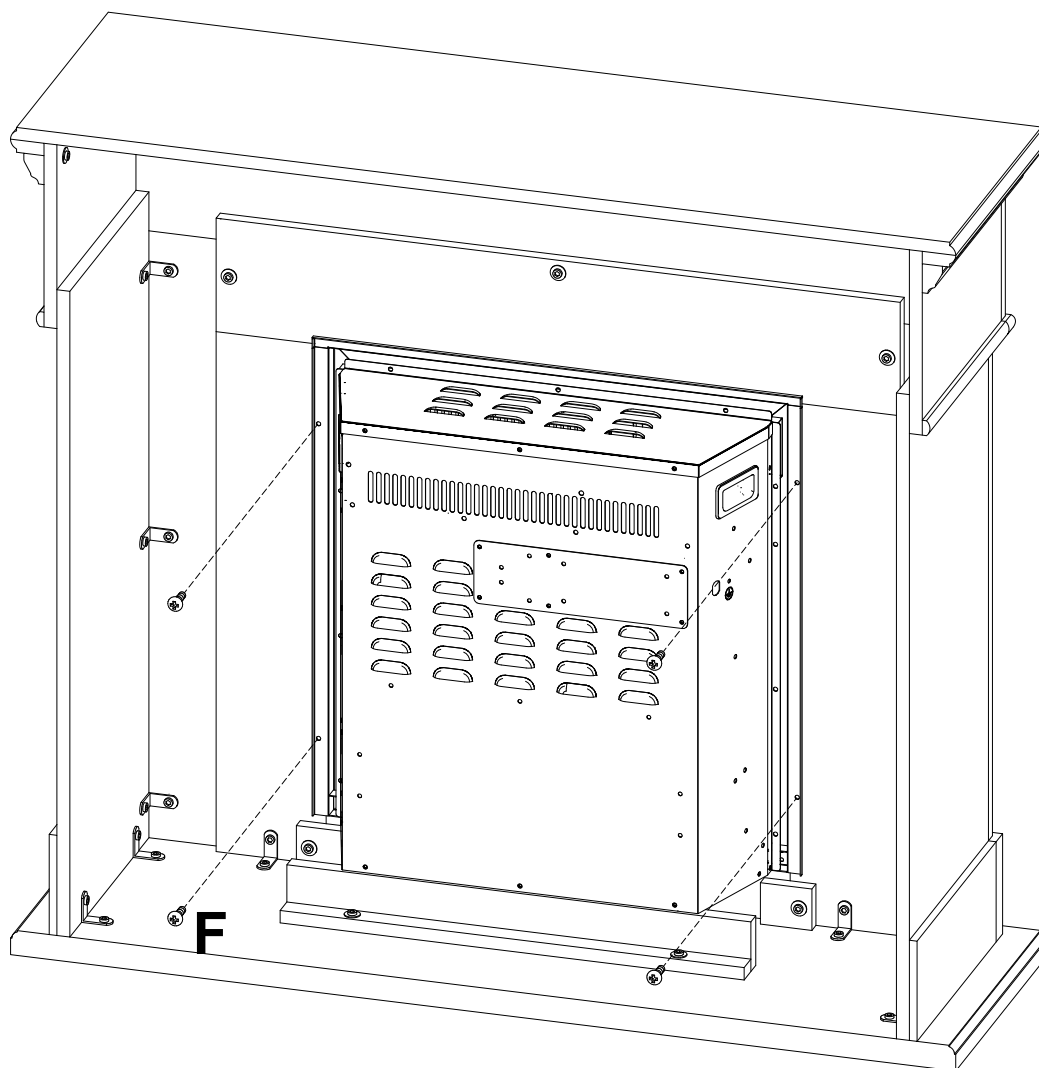

Thank you for purchasing this product! If you have any questions about the product, such as missing parts, damaged products, product assembling, and operation, please contact us via customer service number: **213-4467172 or 661-4358826.**

IMPORTANT

Please call our customer service department for any consulting:

213-4467172

661-4358826

(8:30am - 5:30pm P.S.T.)

DATED PROOF OF PURCHASE IS REQUIRED FOR WARRANTY SERVICE.

AVIS

Veillez appeler le service à la clientèle pour toutes questions au:

213-4467172

661-4358826

(8:30am - 5:30pm P.S.T.)

PREUVE D'ACHAT ORIGINALE REQUISE POUR SERVICE DE GARANTIE.

IMPORTANTE

Sólo hay que llamar nuestro departamento de servicio al cliente en caso de tener preguntas o inquietudes:

213-4467172

661-4358826

(8:30am - 5:30pm P.S.T.)

SE REQUIERE PRUEBA DE COMPRA CON FECHA PARA SERVICIO BAJO GARANTÍA.

**Address: ROWAN ELECTRIC APPLIANCE LLC
750S. Valley View Avenue, San Bernardino, CA 92408
Phone: 213-4467172 or 661-4358826**