

SHOWER DOOR (SHOWER ENCLOSURE) INSTALLATION INSTRUCTION

PLEASE REVIEW THIS ENTIRE MANUAL PRIOR TO INSTALLATION

6 &&G Series

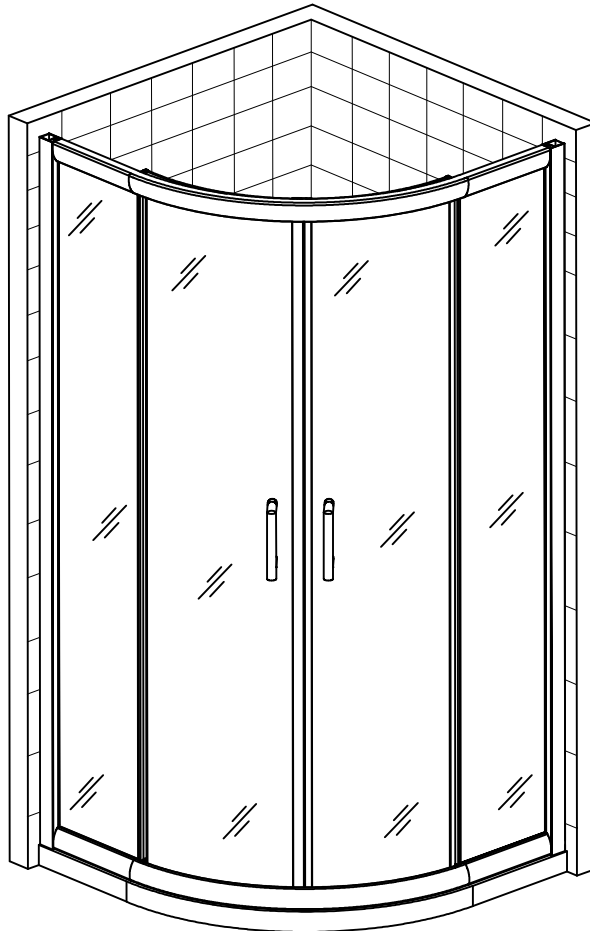

NOTE:

In order to improve the product and customer experience, we reserve the right to change, modify or re-design the product at any time without notice.

Please refer to the latest technical drawings, installation manuals, warranty information or other product details.

Contact us for any issue prior to return.



Installation Instructions Video

Important Notice

This product should be installed by personnel familiar with the construction requirements of such projects, and pay attention to safe installation and operation.

- * To prevent damage or serious injury, do not lean on installed panels/doors/glass.
- * Do not attempt to lift or move heavy glass alone, use professional glass suction cups when handling alone.
- * Installation of some models may require drilling holes in the threshold, for any questions regarding drilling holes in the base, tub or threshold material, contact the manufacturer of the base, tub or threshold material.
- * All drawings in this installation manual are for reference only.



This product should be installed by someone familiar with the construction requirements for this type of project and the care necessary for the safe installation and operation of the product.



◆ General information

Please inspect the product immediately upon receipt for transit damage, missing packs/parts or manufacturing fault. Damage reported later cannot be accepted. Please handle the product with care avoiding knocks and shock loading to all sides and edges of the glass.



Note: Safety glass can not be re-worked.

- Please read these instructions carefully before start of installation.
- Special care should be taken when drilling walls to avoid hidden pipes or electrical cables.
- Note: this product is heavy and required two persons install.

Aftercare instructions

- After use, your shower should be cleaned with soap and water. This is particularly important in hard water districts where insoluble lime salts may be deposited and allowed to build up.
- Cleaners of gritty or abrasive nature should not be used. Care should be taken to avoid contact with strong chemicals such as organic solvents and strippers.
- Glass cleaners can be used but with caution, if in doubt contact the manufacturer of the cleaner in question.
- Please keep these instructions for aftercare and customer service details.

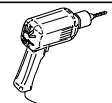
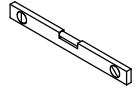
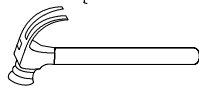
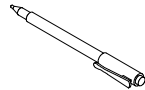
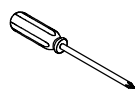
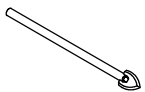
TOOLS REQUIRED

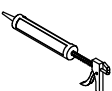
DESCRIPTION	PART IMAGE	DESCRIPTION	PART IMAGE
Tape measure		Drill	
Spirit level		Hammer	
Pencil		Cross head Screwdriver	
Ø6/3.2mm Drill bit		Inner hexagon Spanner	
Silicone Sealant			

ASSEMBLY INSTRUCTIONS-DRAWING

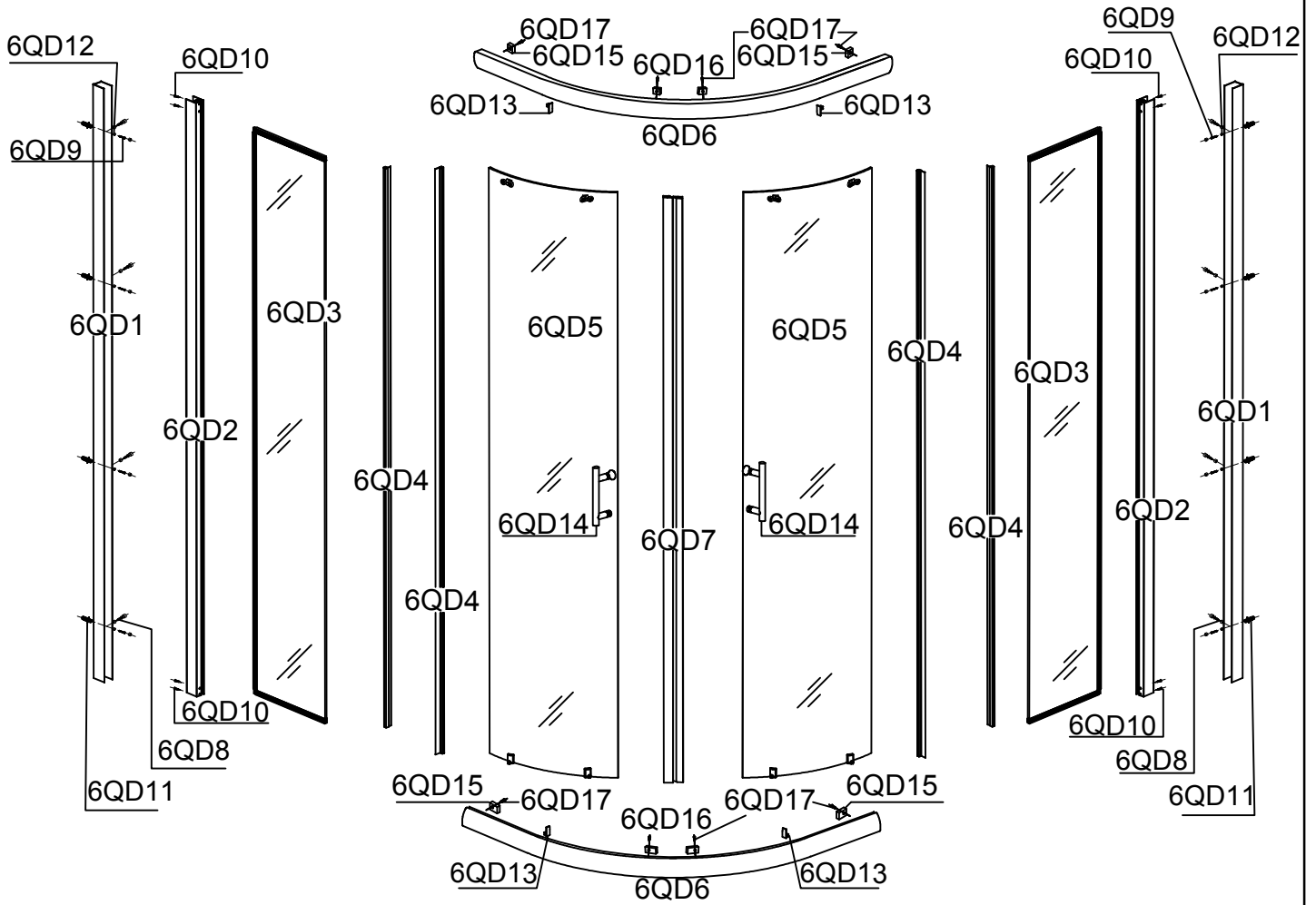

NO.	Diagram	QTY	Description
6QD1	Wall profile	2	
6QD2	Wall profile	2	
6QD3	Fixed glass	2	
6QD4	Water retaining strip	4	
6QD5	Movable glass	2	
6QD6	Slideway	2	
6QD7	Magnetic adhesive strip	2	
6QD8	Metric Screw(3.9x10)	8	
6QD9	Metric Screw(3.9x30)	8	

NO.	Diagram	QTY	Description
6QD10	Metric Screw(3.9x30)	8	
6QD11	Wall anchor	8	
6QD12	Screw cover cap	8	
6QD13	Decorative cover	4	
6QD14	Handle	2	
6QD15	Rubber block	4	
6QD16	Rubber block	4	
6QD17	Metric Screw(3.9x20)	8	

Step 1

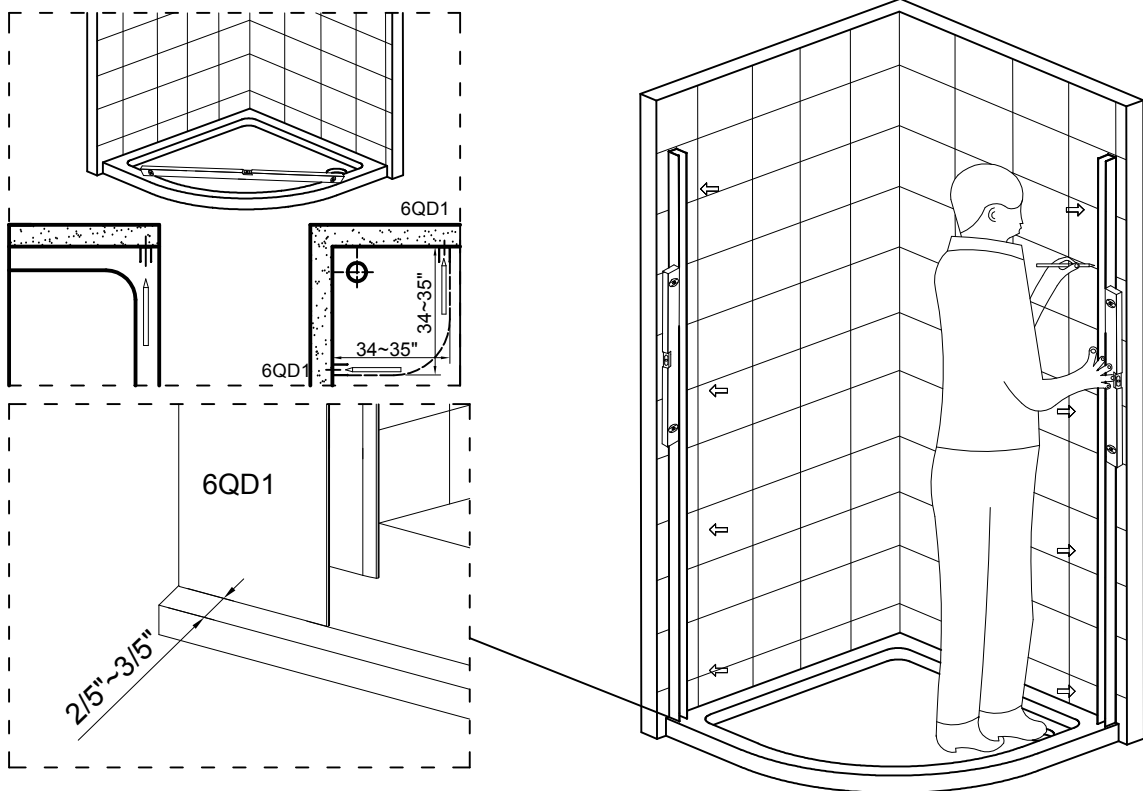

1.1 Place the Part (6QD1) vertically 2 5/8"~3 5/8" from the edge of the shower base, ensuring that the components are vertical, then mark the holes with a pencil.

Step 2

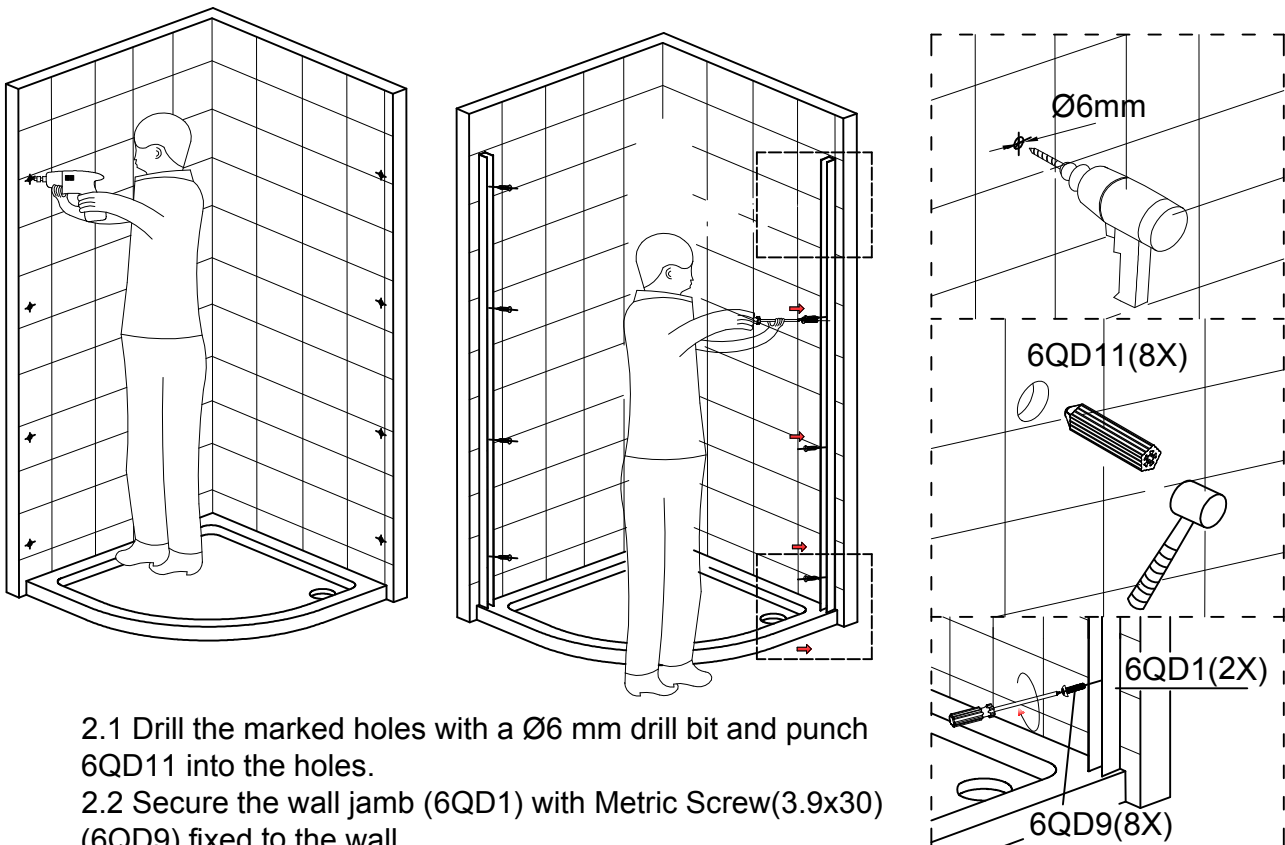

2.1 Drill the marked holes with a Ø6 mm drill bit and punch 6QD11 into the holes.

2.2 Secure the wall jamb (6QD1) with Metric Screw(3.9x30) (6QD9) fixed to the wall.

Step 3

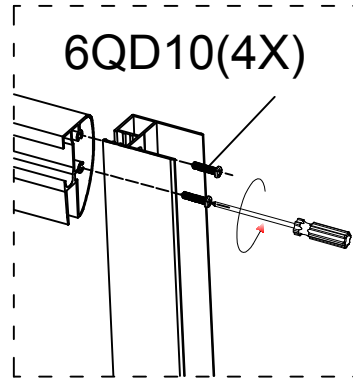
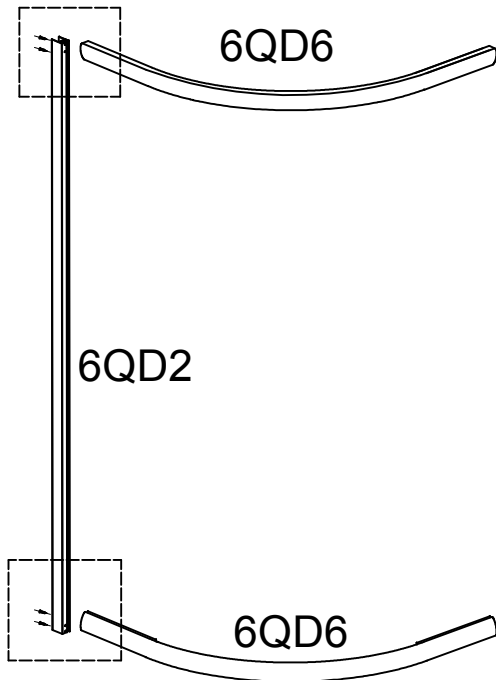

3.1 Part (6QD6) and Part (6QD2) are locked together by Part (6QD10). Note: Left side.

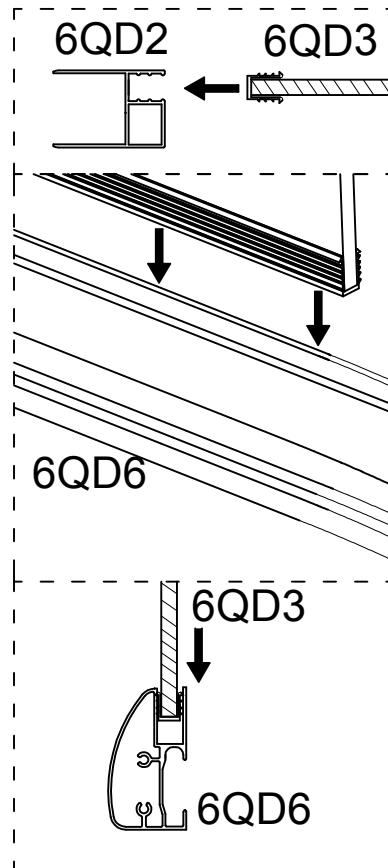
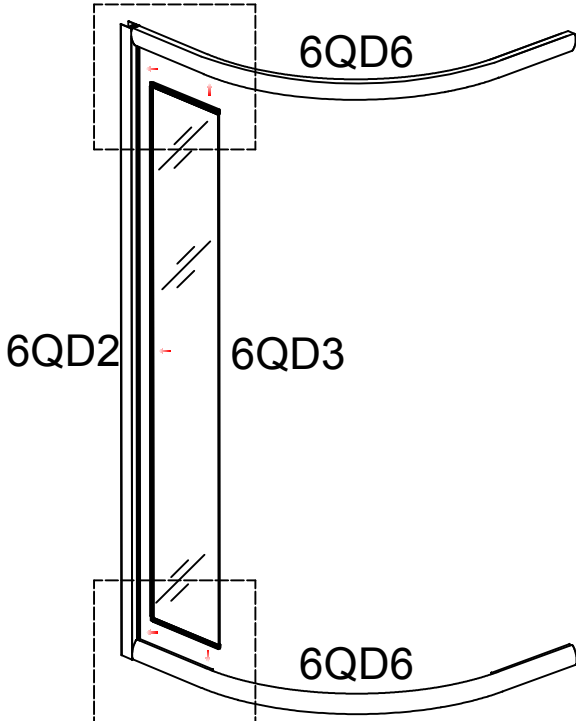

3.2 Snap Part (6QD3) into slot of Part (6QD2) and Part (6QD6).

Step 4

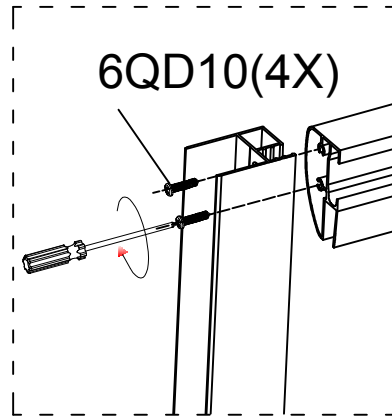
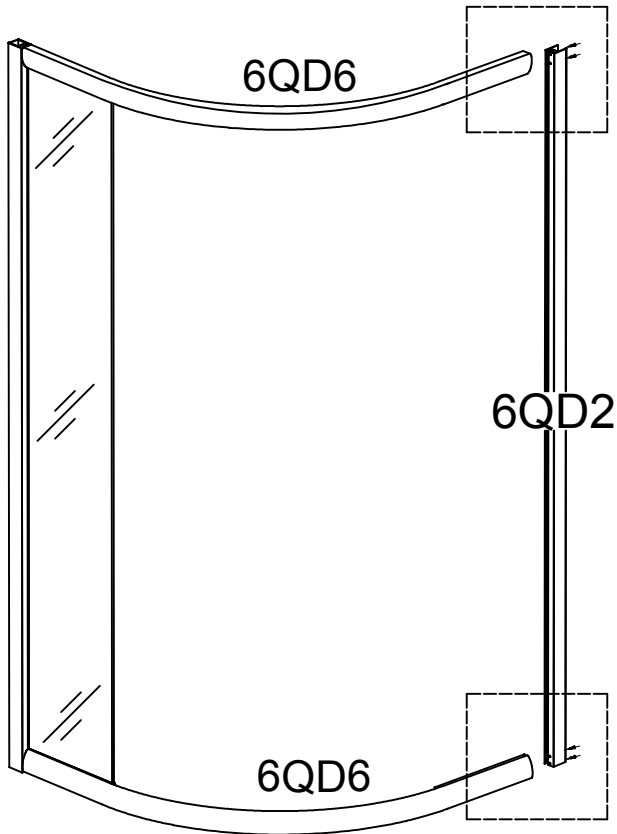

4.1 Part (6QD6) and Part (6QD2) are locked together by Part (6QD10). Note: Right side.

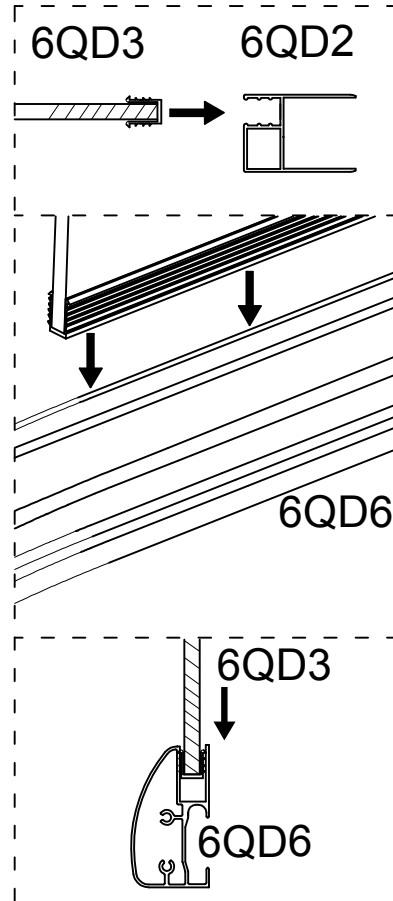
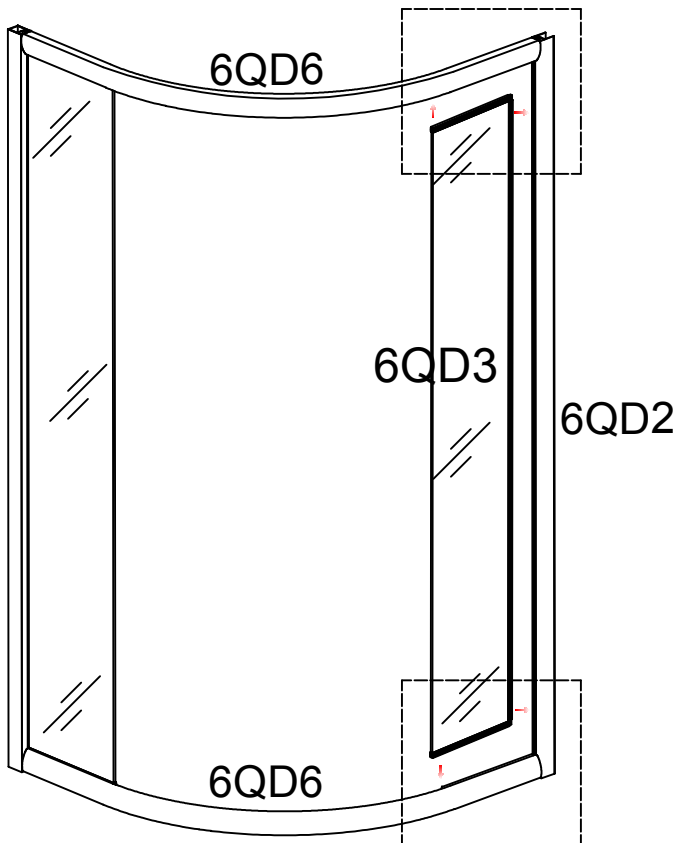

4.2 Snap Part (6QD3) into slot of Part (6QD2) and Part (6QD6).

Step 5

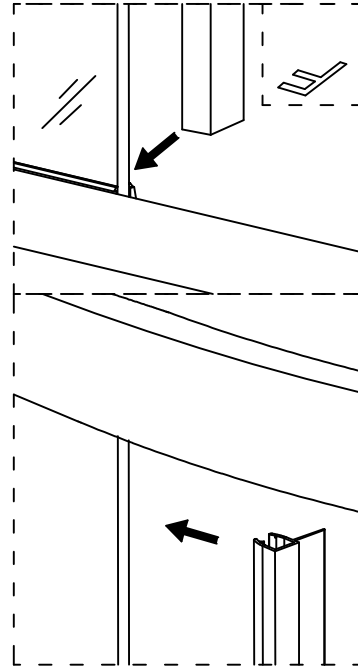
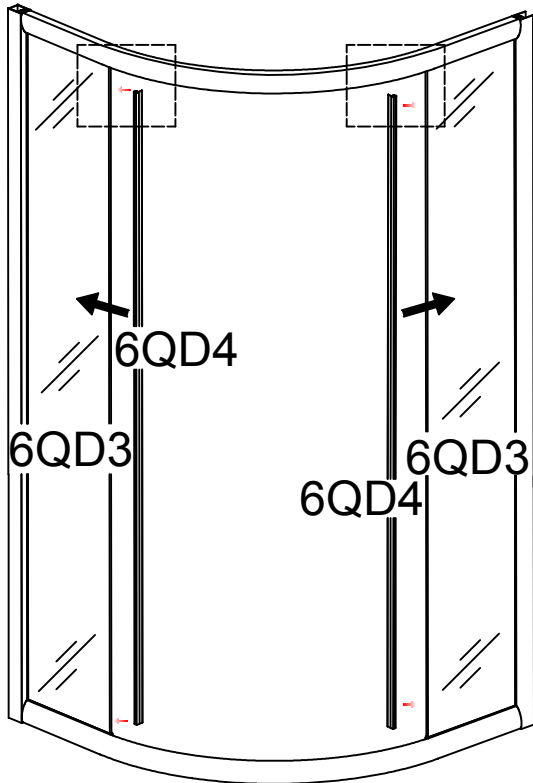

5.1 Snap Part (6QD4) into Part (6QD3).

Step 6

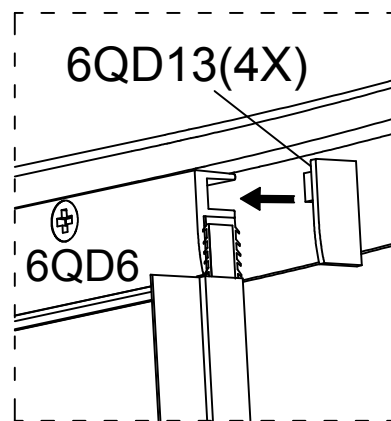
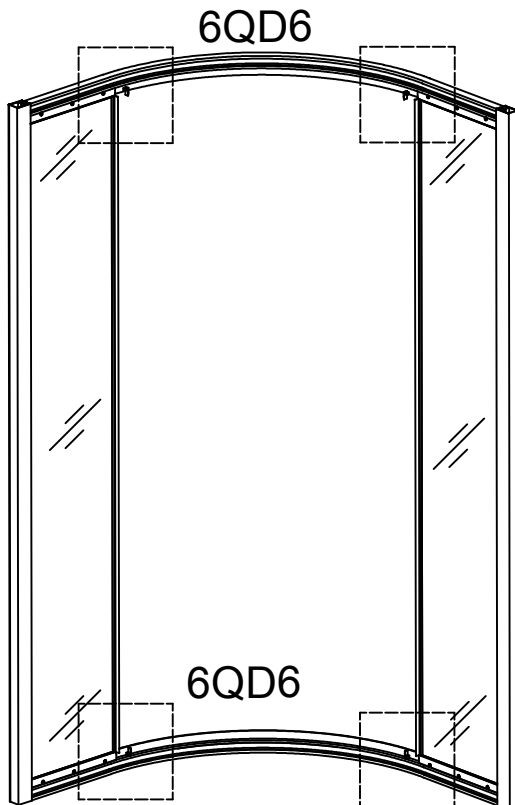

6.1 Install Part (6QD13) on the Part (6QD6).

Step 7

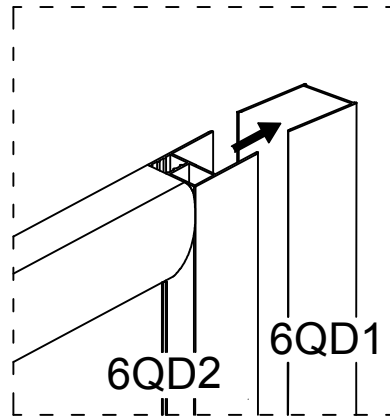
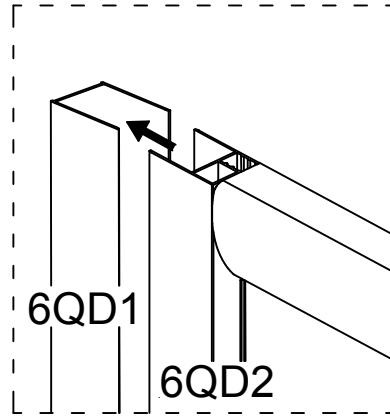
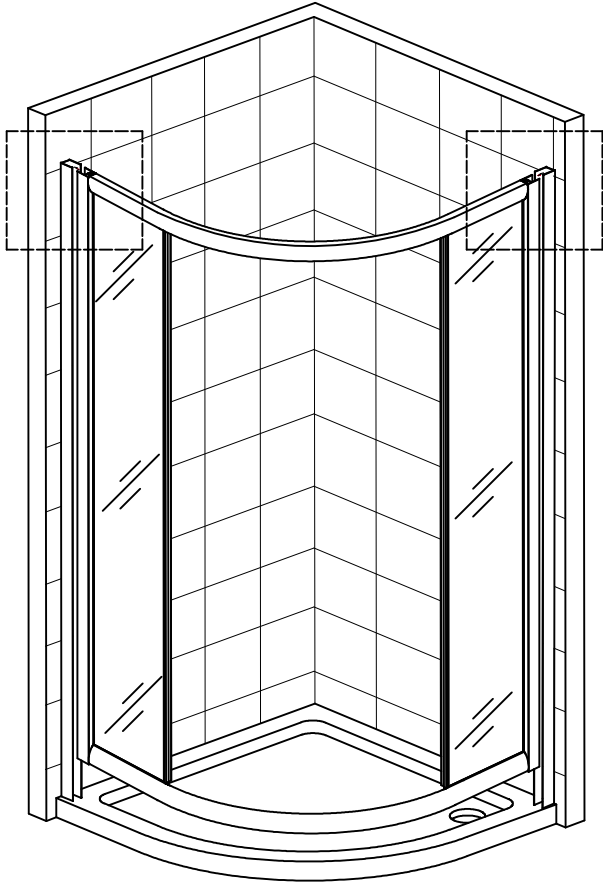

7.1 Snap Part (6QD2) into Part (6QD1).

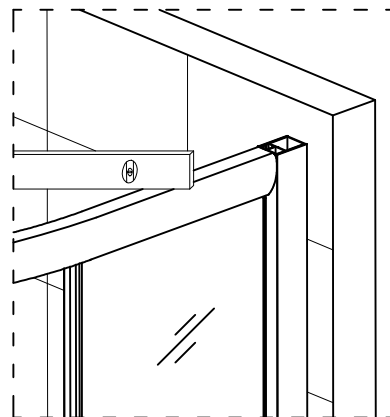
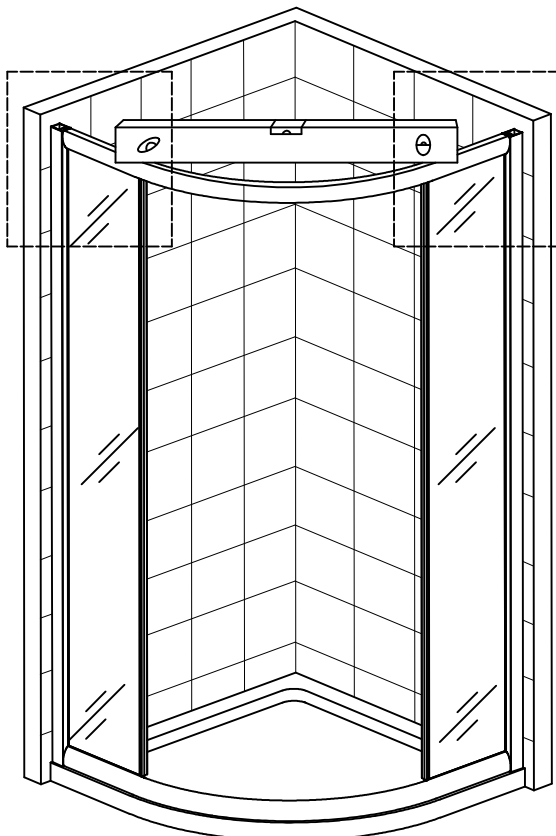

7.2 Adjust the position correctly with a spirit level to ensure levelling.

Step 8

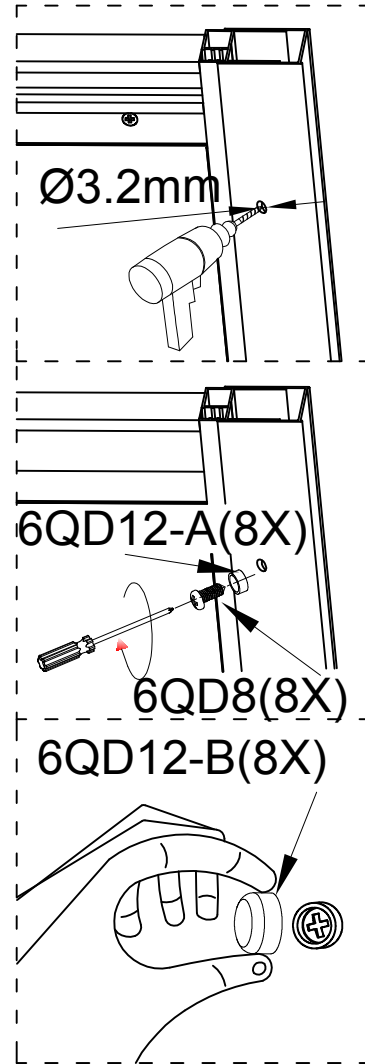
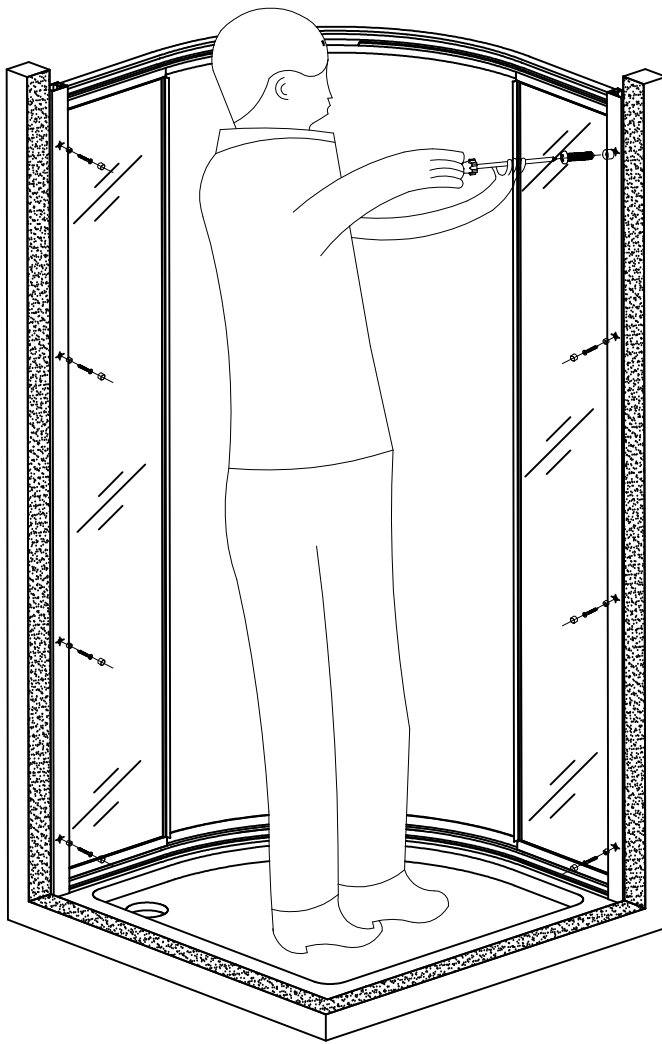

- 8.1 Drill the holes with a $\text{Ø}3.2\text{mm}$ drill bit.
- 8.2 Thread the metric Screw (3.9×10) ($6\text{QD}8$) onto the screw cover cap ($6\text{QD}12\text{-A}$), then lock it to the wall jamb and finally close the screw cover cap ($6\text{QD}12\text{-B}$).

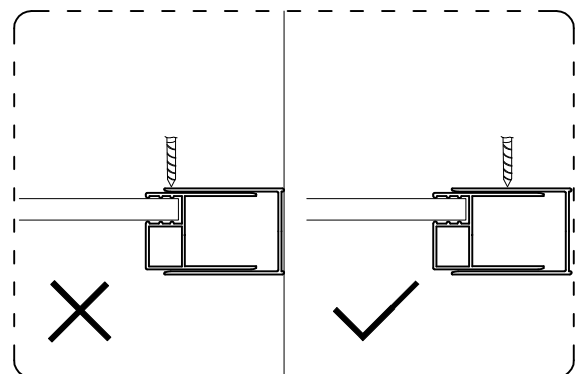

Step 9

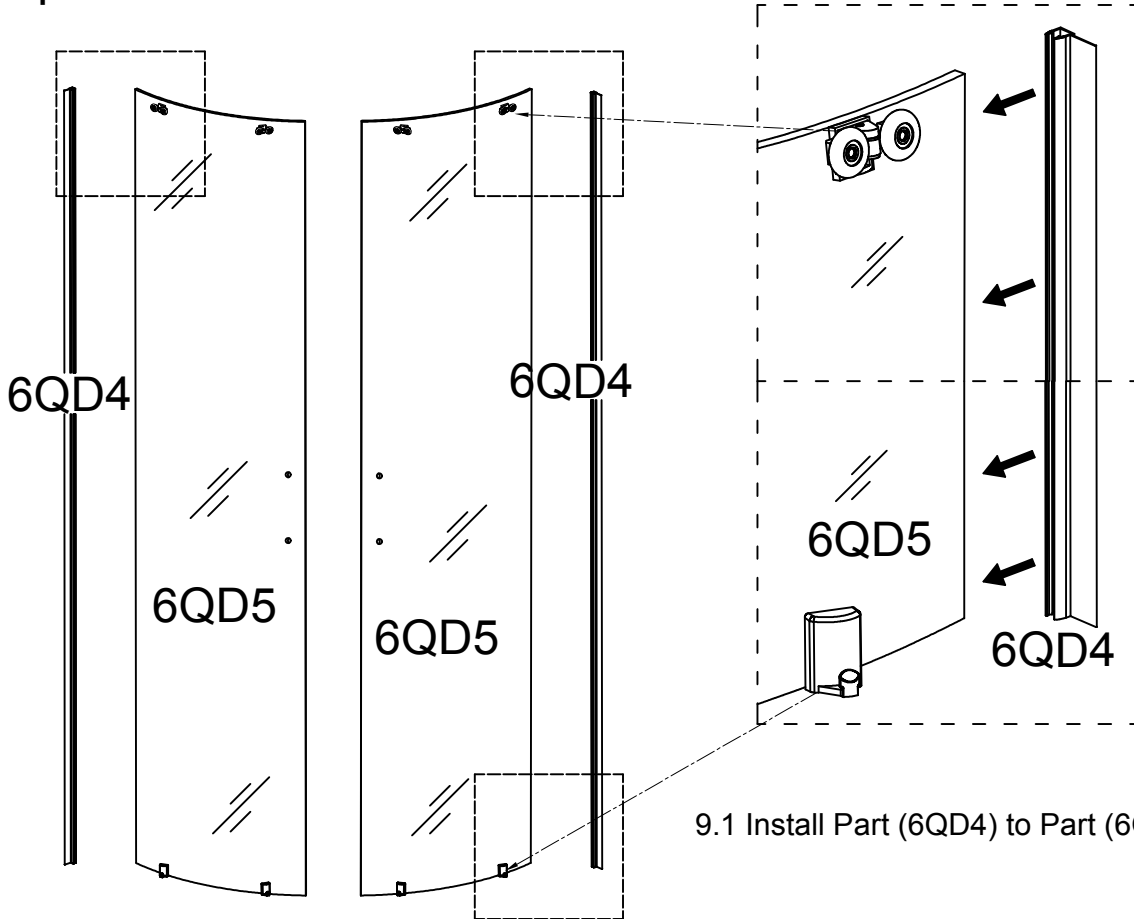

9.1 Install Part (6QD4) to Part (6QD5) separately.

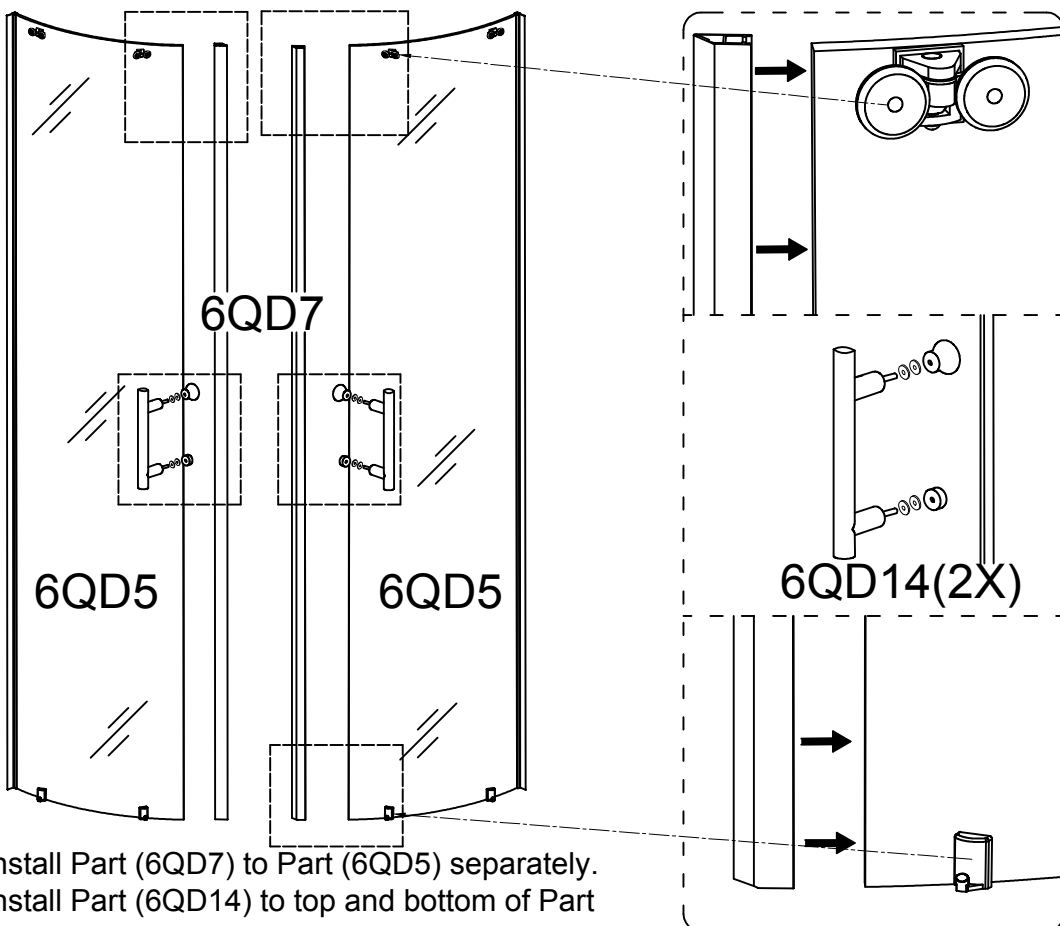

9.2 Install Part (6QD7) to Part (6QD5) separately.
9.3 Install Part (6QD14) to top and bottom of Part (6QD5).

Step 10

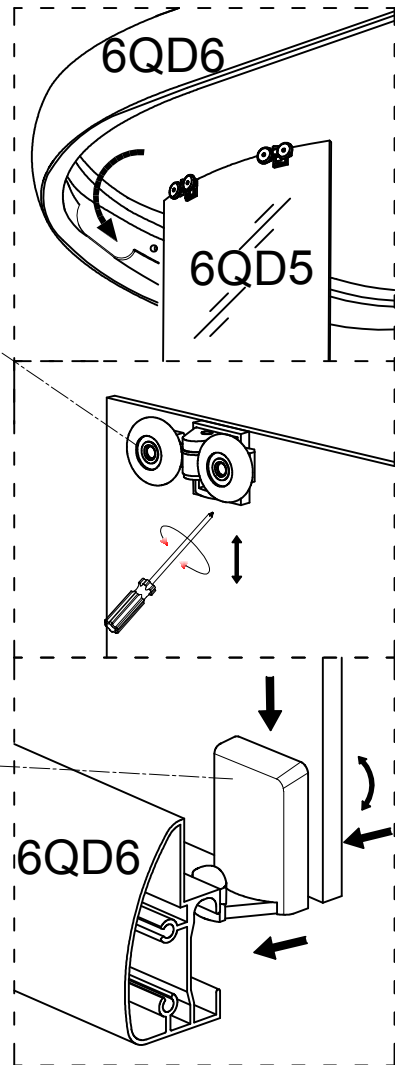
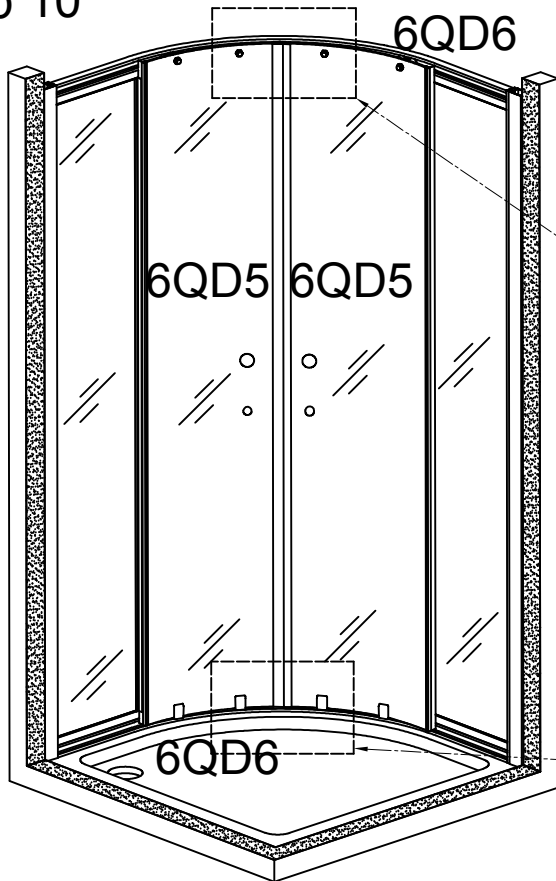

10.1 Hang Part (6QD5) to Part (6QD6).
Note: The pulley must be sat in the slot of the Part (6QD6).

Step 11

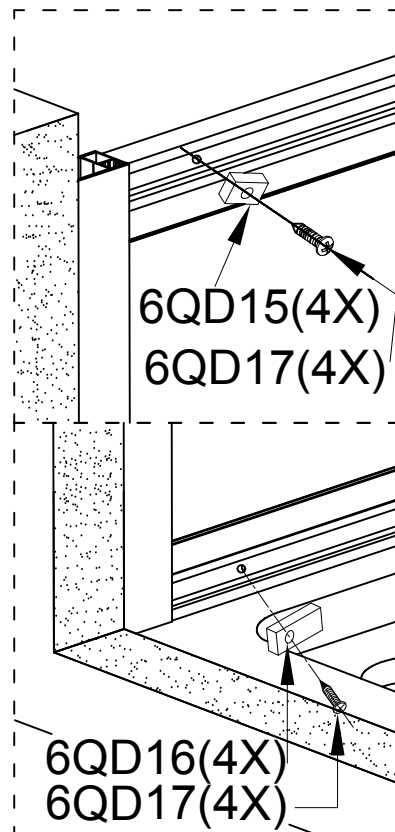
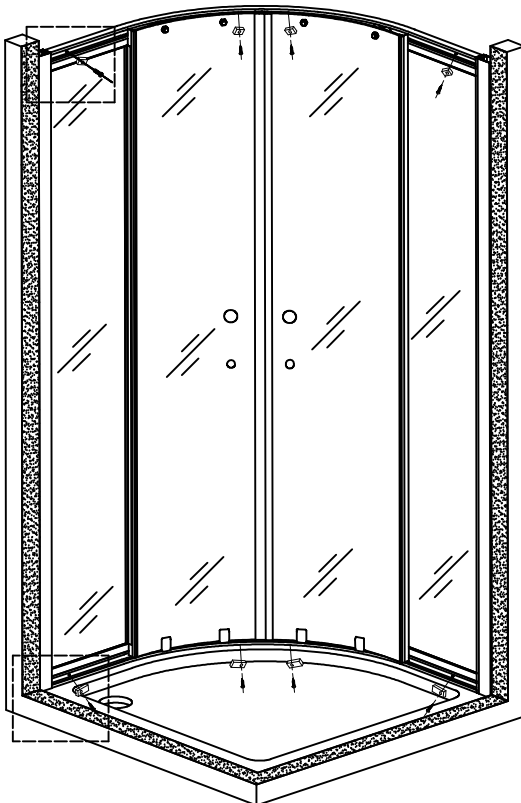

11.1 Install Part (6QD15) and Part (6QD16) to top and bottom of Part (6QD6) separately by Part (6QD17).

Step 12

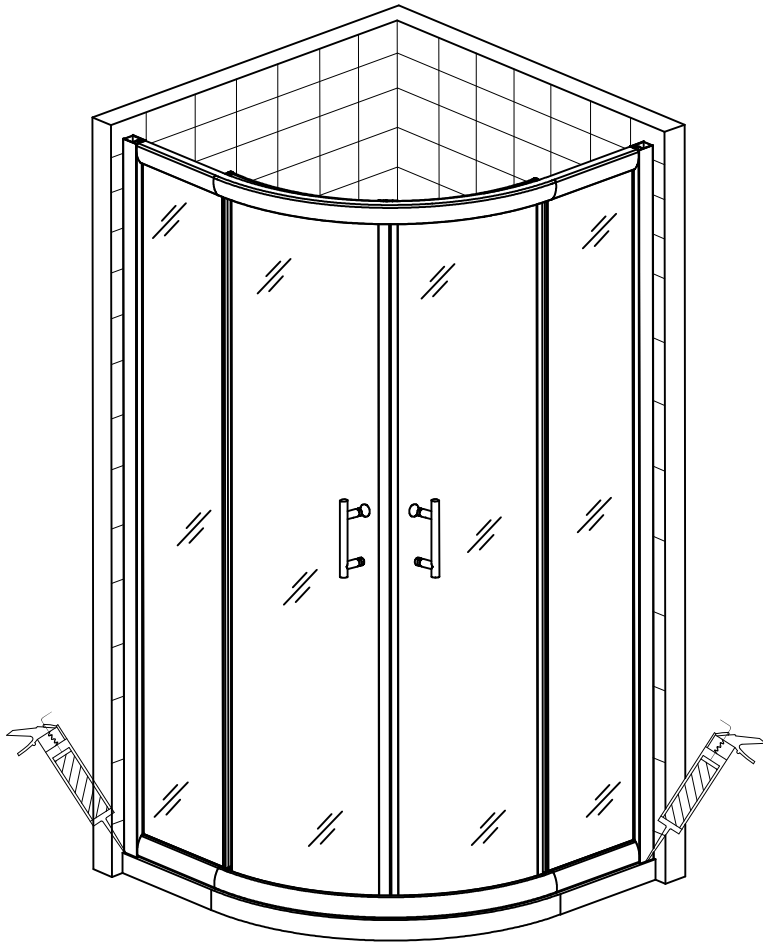

Allow 24 hours for silicone to dry before use.
Silicone on the outside edge only

Product Maintenance

BASES and BACKWALLS: To ensure long lasting life for your acrylic back walls: wipe them off after each use with a soft cloth. To clean the acrylic back walls use non-abrasive sprays or cream based cleaners. Avoid the use of aerosol spray cleaners. Never use abrasive cleansers, metal brushes or scrapers that could permanently scratch or dull the surface.

GLASS: To ensure long lasting life for your glass shower products: wipe them off after each use with a soft cloth. Rinse and wipe off the glass using either a soft cloth or a squeegee to prevent soap buildup and water spots (Hard water can etch the surface of the glass over time if left to dry). To prevent scratching the surface: never use abrasive cleaners or cleaning products that contain scouring agents. Never use bristle brushes or abrasive sponges that may scratch the surface of the glass.

HARDWARE: To ensure a long lasting finish: wipe off all metal parts after each use with a soft cloth. Do not use abrasive cleaners or cleaning products containing ammonia, bleach or acid. If accidentally used, rinse the surface as soon as possible to prevent damage to the finish (peeling or corrosion). After cleaning the polished finishes, rinse thoroughly and wipe dry with a soft clean-cloth. Clean stainless steel surfaces at least once a week. When applying stainless steel cleaner or polish to stainless steel hardware, work with the grain (not across the grain). Never use an abrasive sponge or cloth, steel wool or wired brush as these may permanently scratch the surfaces.



To maximize the life of your door, it is important to regularly inspect the glass and other hardware for misalignment, proper attachment, and/or damage.

Maintenance Checklist

Check that the unit is stable, operates smoothly and that the installation is secure

Confirm that all screws are tight

Confirm that all vinyl seals are intact (replace if missing or damaged to prevent water leakage)

Inspect exposed and concealed glass edges for damage

Damaged Glass Must be Replaced