

Hampton Solid Wood Bed Queen Size

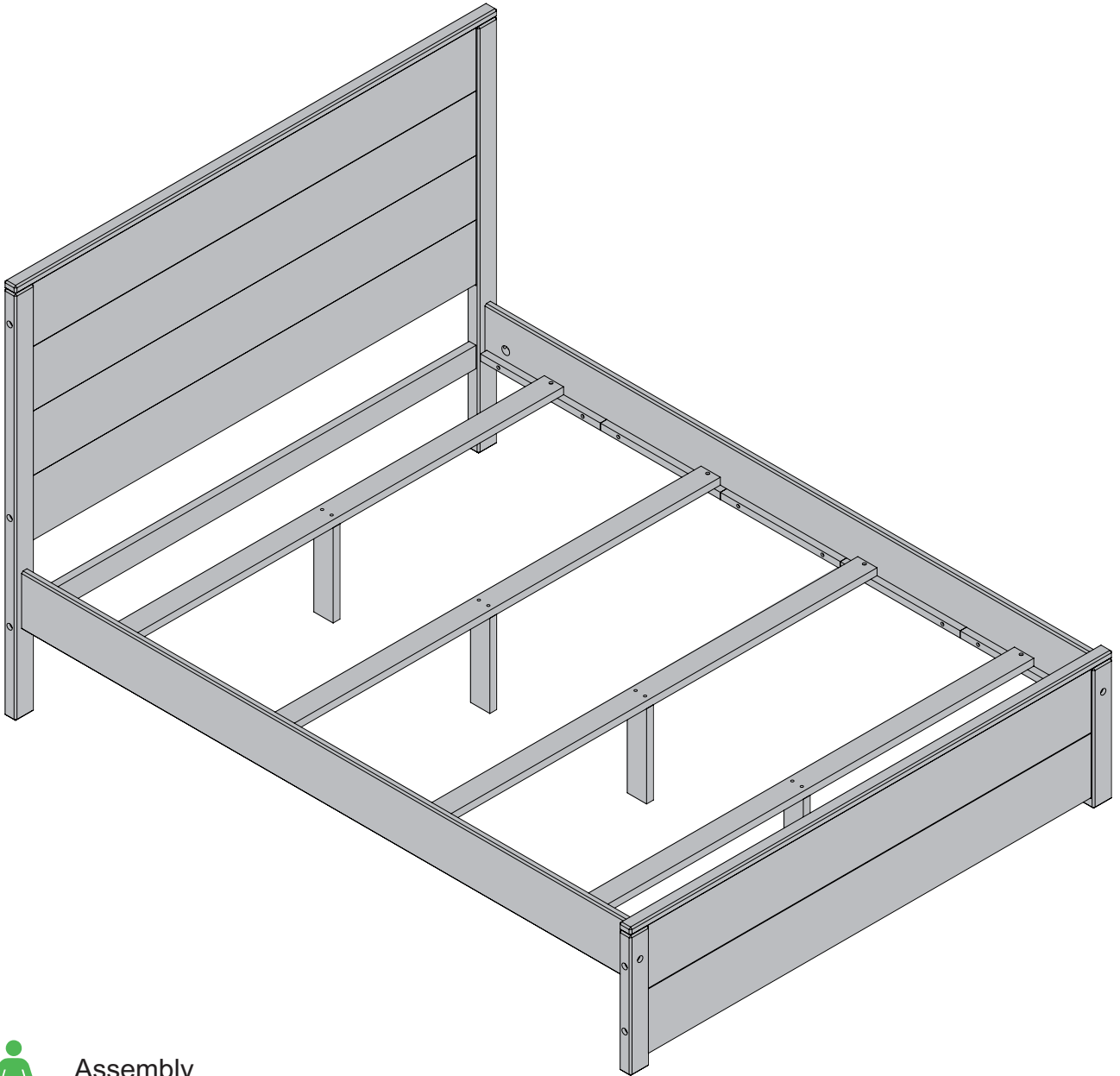

Assembly
02 people



Time
1:30 hours approximately



Tools
philips key, rubber hammer



Volume quantity
01 box



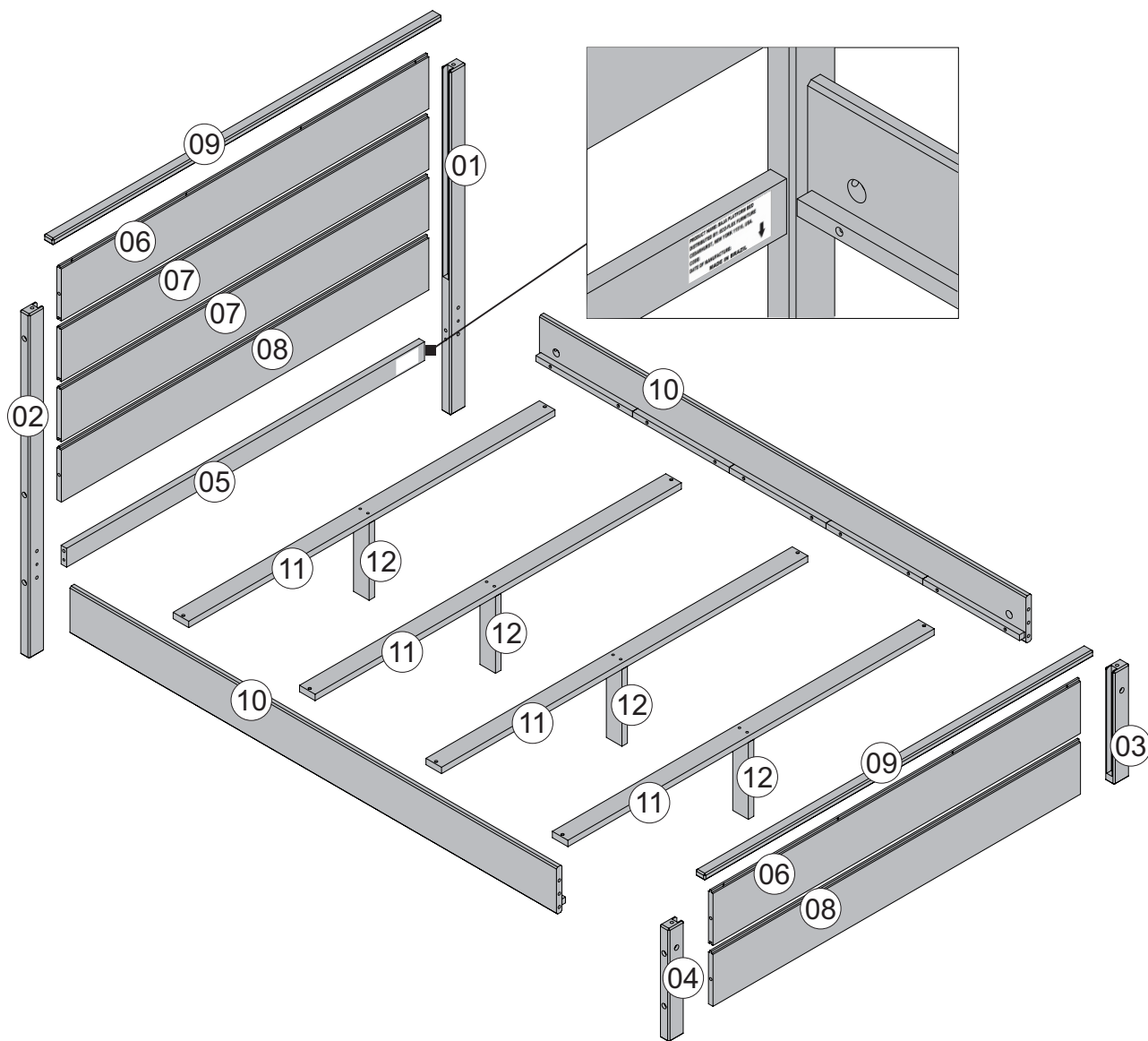



Parts list for assembly. Please confirm all parts available before assembly

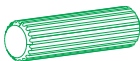
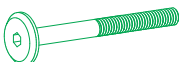

ATTENTION

- * Read and observe carefully all the assembly instructions before beginning assembly.
- * The assembly of the product must be done on a clean and flat surface. We suggest to use the packaging to cover the floor to avoid damages.
- * The screws must be tightened periodically.
- * Avoid contact with sharp objects.
- * Avoid banging pieces together.

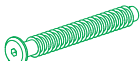
Hardware list for assembly.
Please confirm all hardware available before assembly

A	 ø3/8" x 1' 9/16"	14x	+	SPARE 02x
B	 ø1/4" x 4' 1/4"	14x	+	02x
F		01x	+	01x
AP	 ø1/8" x 1' 3/8"	16x	+	02x
BC	 1/4"	14x	+	02x
BJ	 ø3/4"	12x	+	02x
BL	 ø1/4" x 2"	08x	+	01x
BV	 ø1/4"	04x		

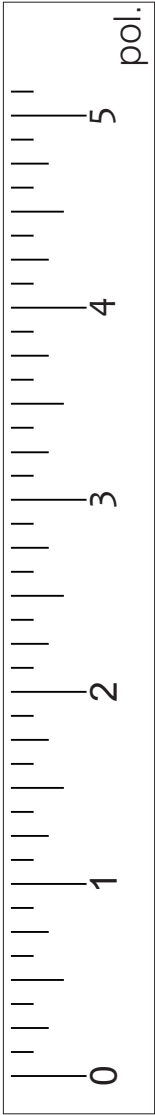

Step - 03

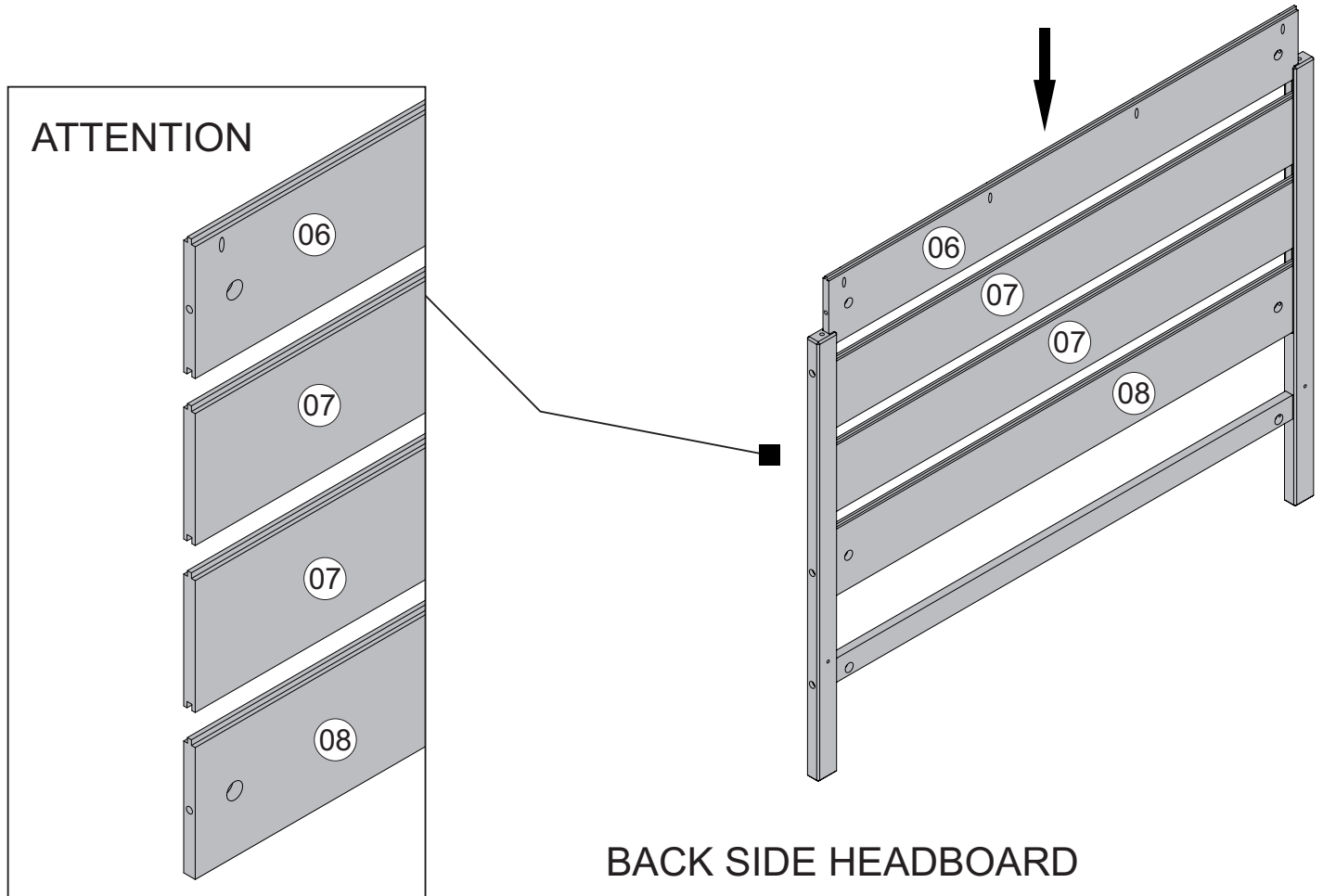

Step - 04

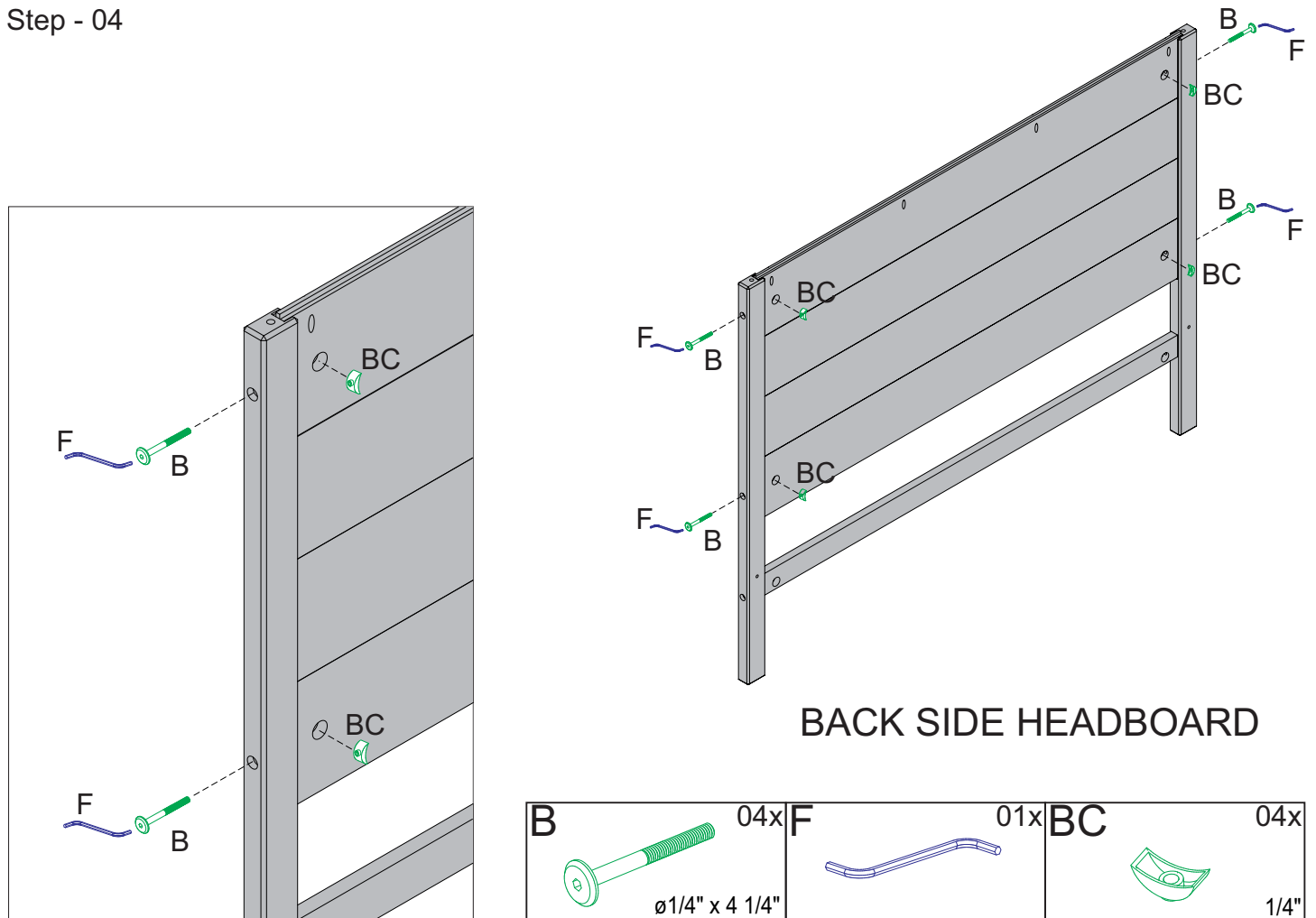

Step - 05

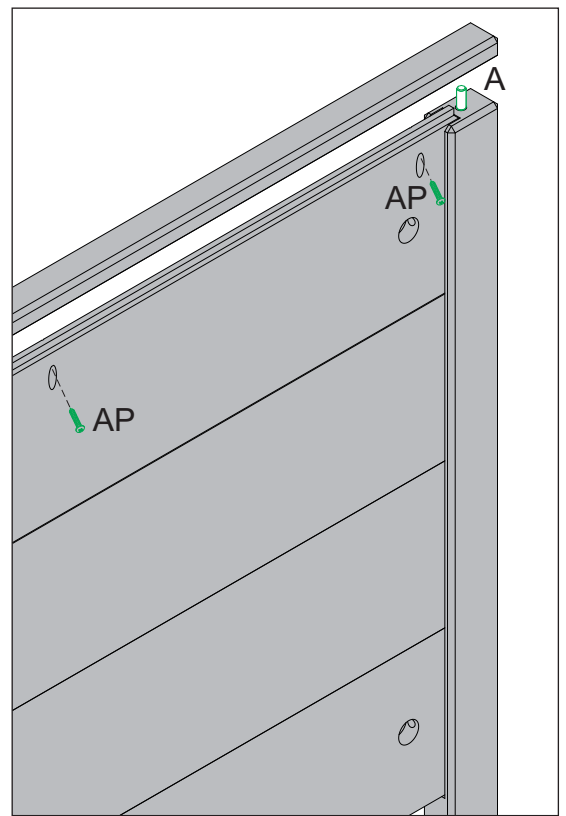
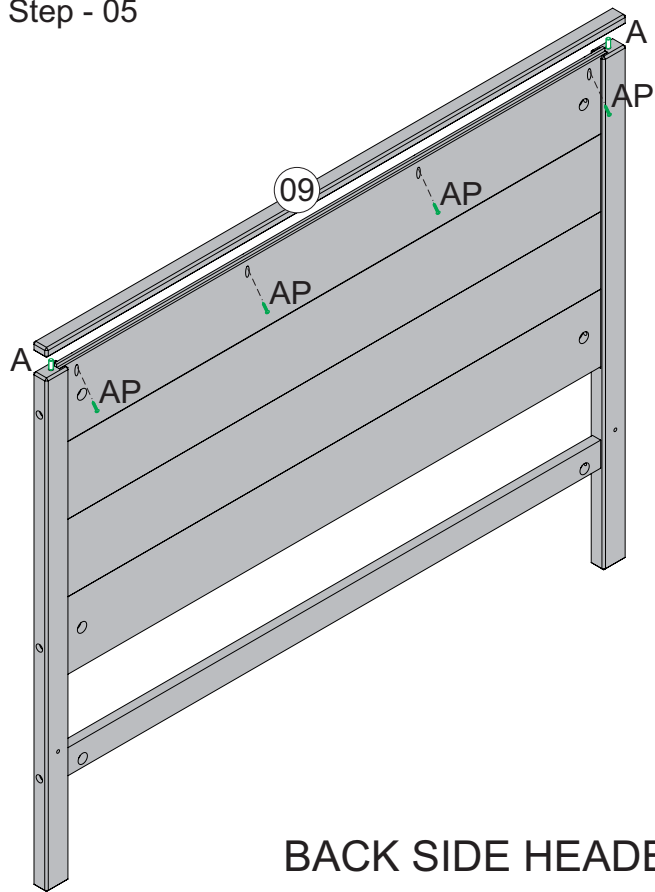

BACK SIDE HEADBOARD

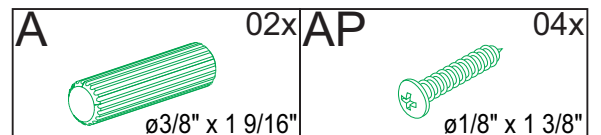

Step - 06

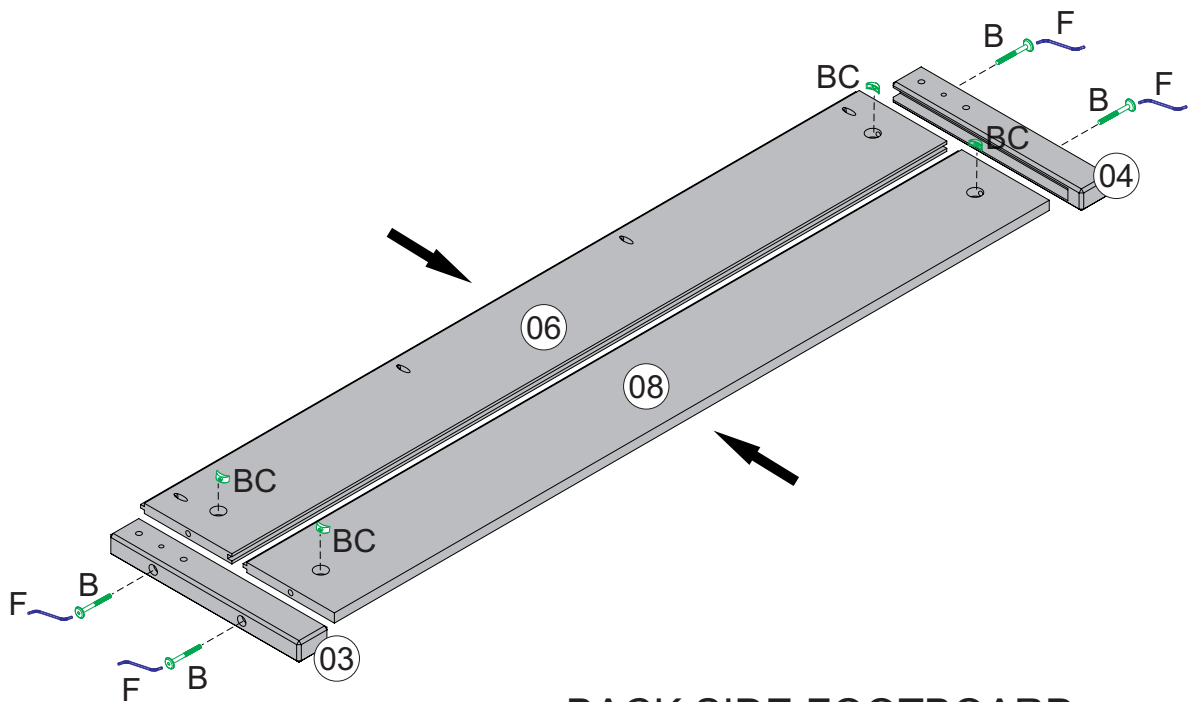

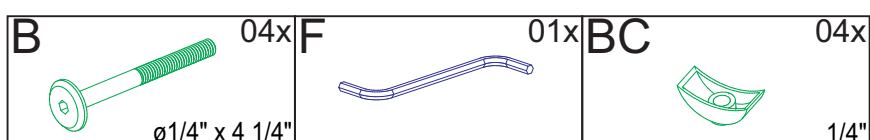

BACK SIDE FOOTBOARD

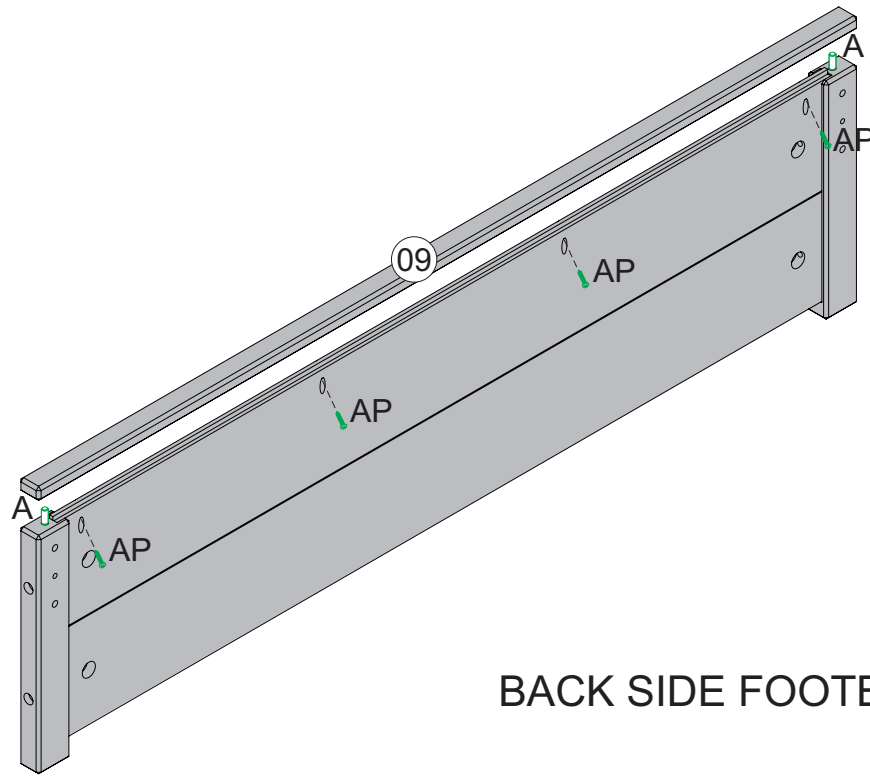



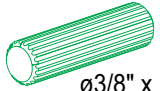

BACK SIDE FOOTBOARD

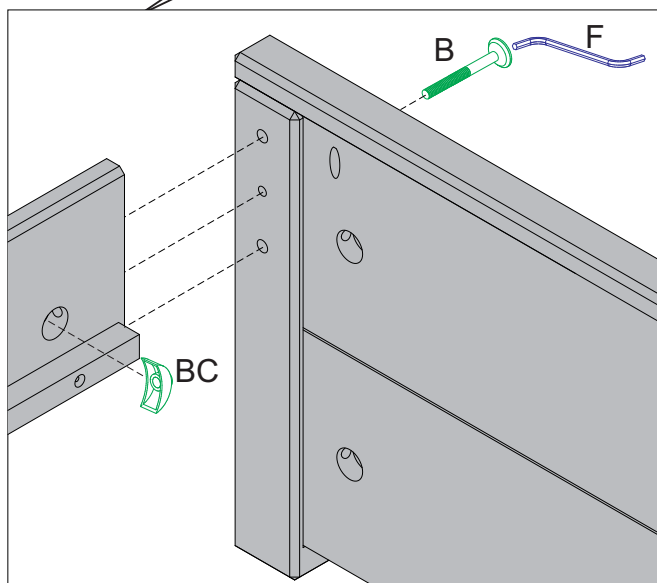
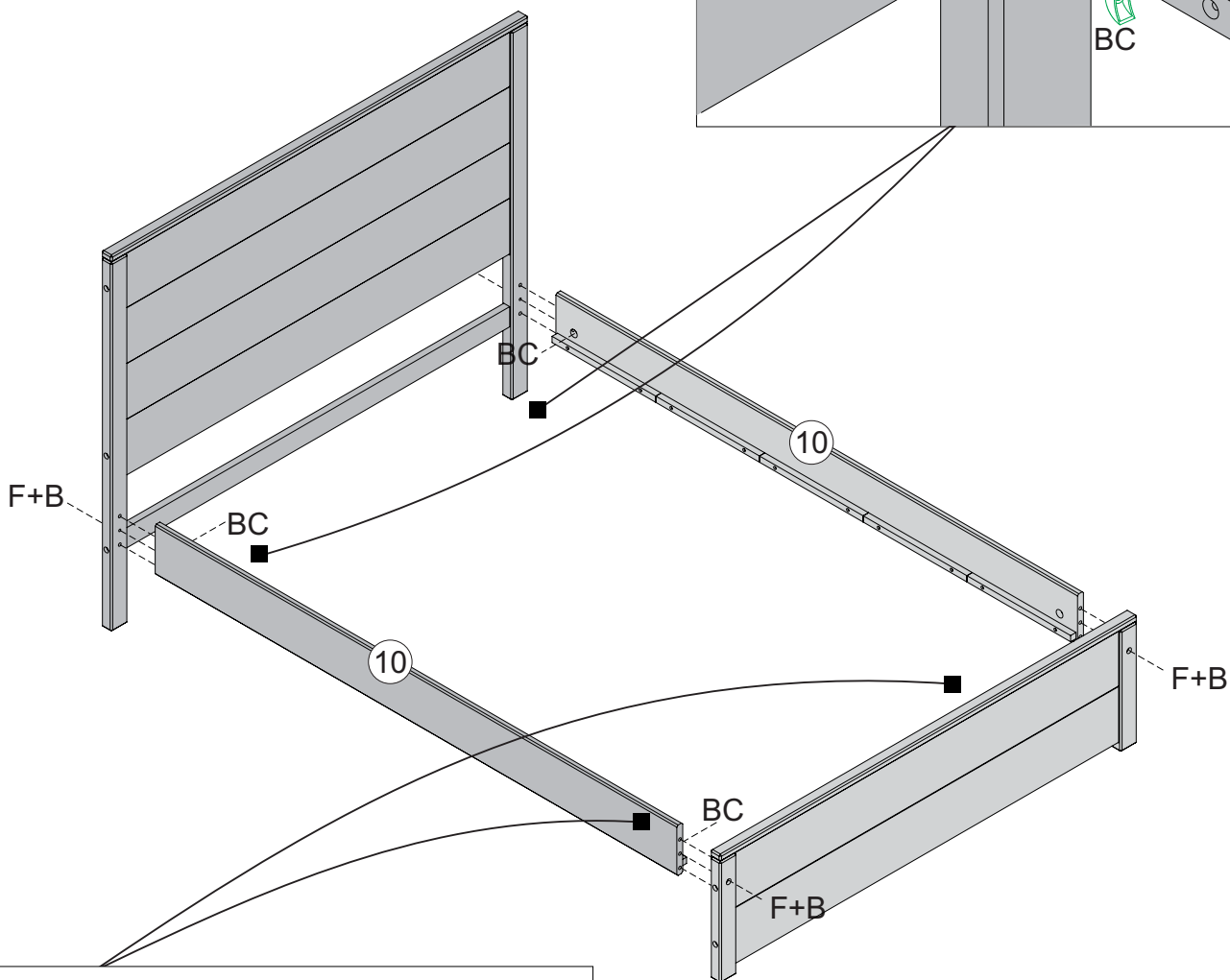
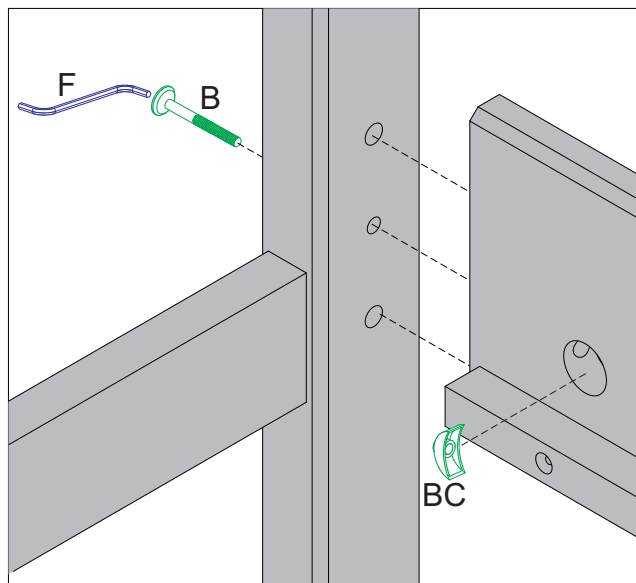
A  02x ø3/8" x 1 9/16"	AP  04x ø1/8" x 1 3/8"
--	--

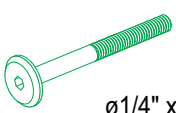

B	04x
	$\varnothing 1/4" \times 4 1/4"$
F	01x
	
BC	04x
	1/4"

