

# ASSEMBLY INSTRUCTIONS

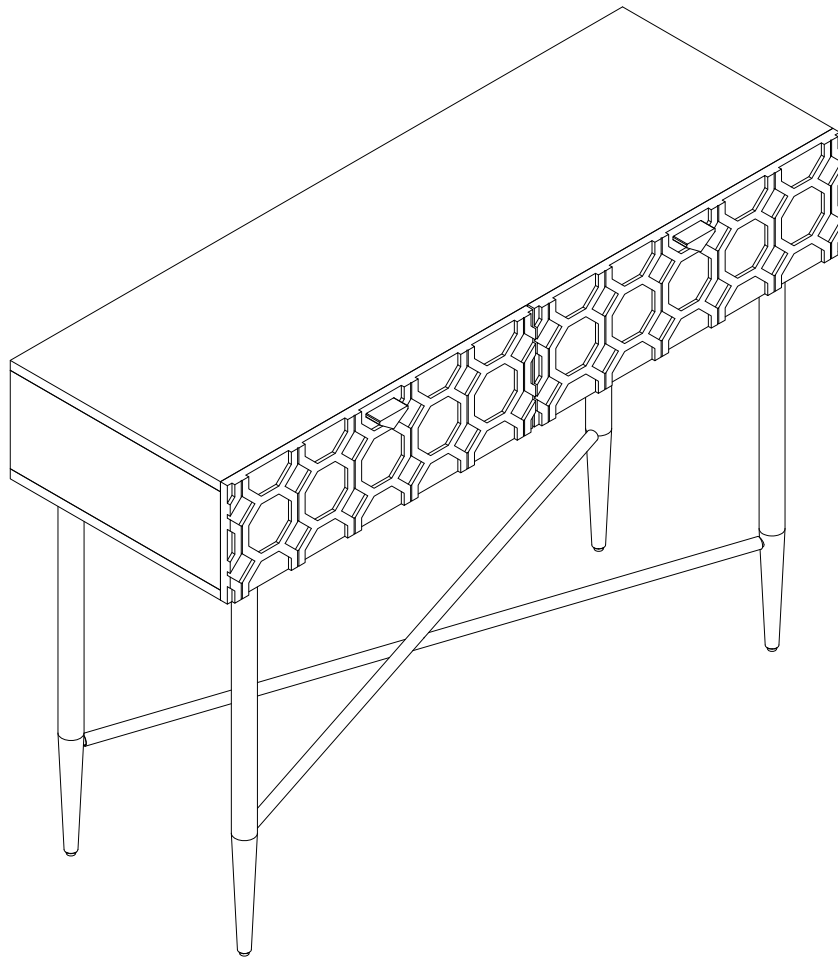

Phone number: 303-747-4421 / (951) 213-4743  
service@clihome.net  
Web: www.clihome.net

# ASSEMBLY INSTRUCTIONS



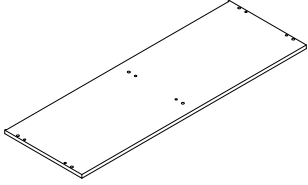
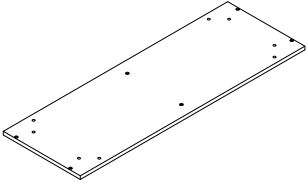
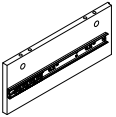
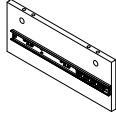
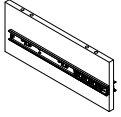
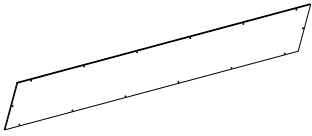
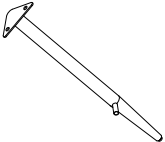
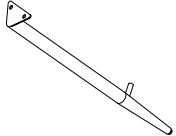



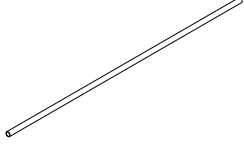
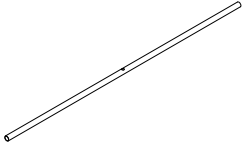
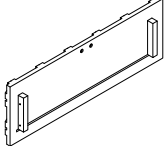
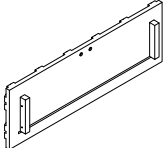
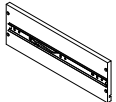
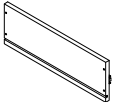
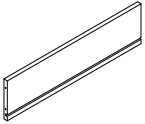
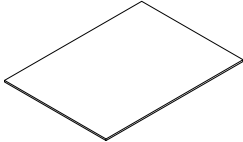

## Part List:

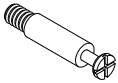
ITEM	DESCRIPTION	PART	QTY
1	Top panel		1
2	Bottom panel		1
3	Left side panel		1
4	Right side panel		1
5	Divider		1
6	Back panel		1
7	Left front leg / Right back leg		2
8	Right front leg / Left back leg		2

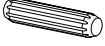





## Part List:

ITEM	DESCRIPTION	PART	QTY
9	Upper bar		1
10	Lower bar		1
11	Left drawer front		1
12	Right drawer front		1
13	Drawer left side		2
14	Drawer right side		2
15	Drawer back		2
16	Drawer bottom		2

## Hardware List:

ITEM	DESCRIPTION	PART	QTY
A	Camlock bolt		6
B	Camlock		6
C	Wooden dowel	 Φ8*30mm	12
D	Bolt	 Φ1/4"*1/2"	12
E	Bolt	 Φ1/4"*1"	1
F	Bolt	 Φ1/4"*1 1/4"	6
G	Allen wrench		1
H	Flat head screw	 Φ4*25mm	16

## Hardware List:

ITEM	DESCRIPTION	PART	QTY
I	Handle		2
J	Machine screw	 Φ5/32"*7/8"	4
K	Back screw	 Φ3*12mm	14
L	Safety wall strap		2
M	Plastic anchor		2
N	Mounting screw	 Φ4*38mm	2
O	Washer		2

- \* Required screwdriver & mallet, not included.
- \* Before discarding packing materials, please check to make sure that all parts and hardware is present.
- \* Two people needed for assembly.
- \* Please follow the instructions closely; do not over tighten screws or bolts unless instructed.
- \* After a few days from initial assembly, the product may have acclimated to the new environment. Please retighten the hardware.

## Guideline For Assembling of Cam Lock(A & B)

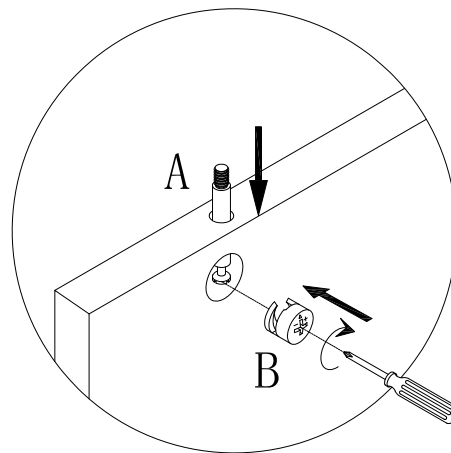
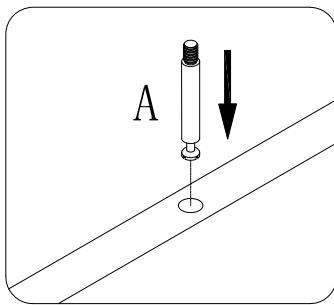



Screw camlock bolt (A) to wood part.

Do not assemble camlock (B) unless instructed.

To assemble camlock (B), ensure long side of the + is facing the bolt (A) before inserting into hole.

# ASSEMBLY INSTRUCTION

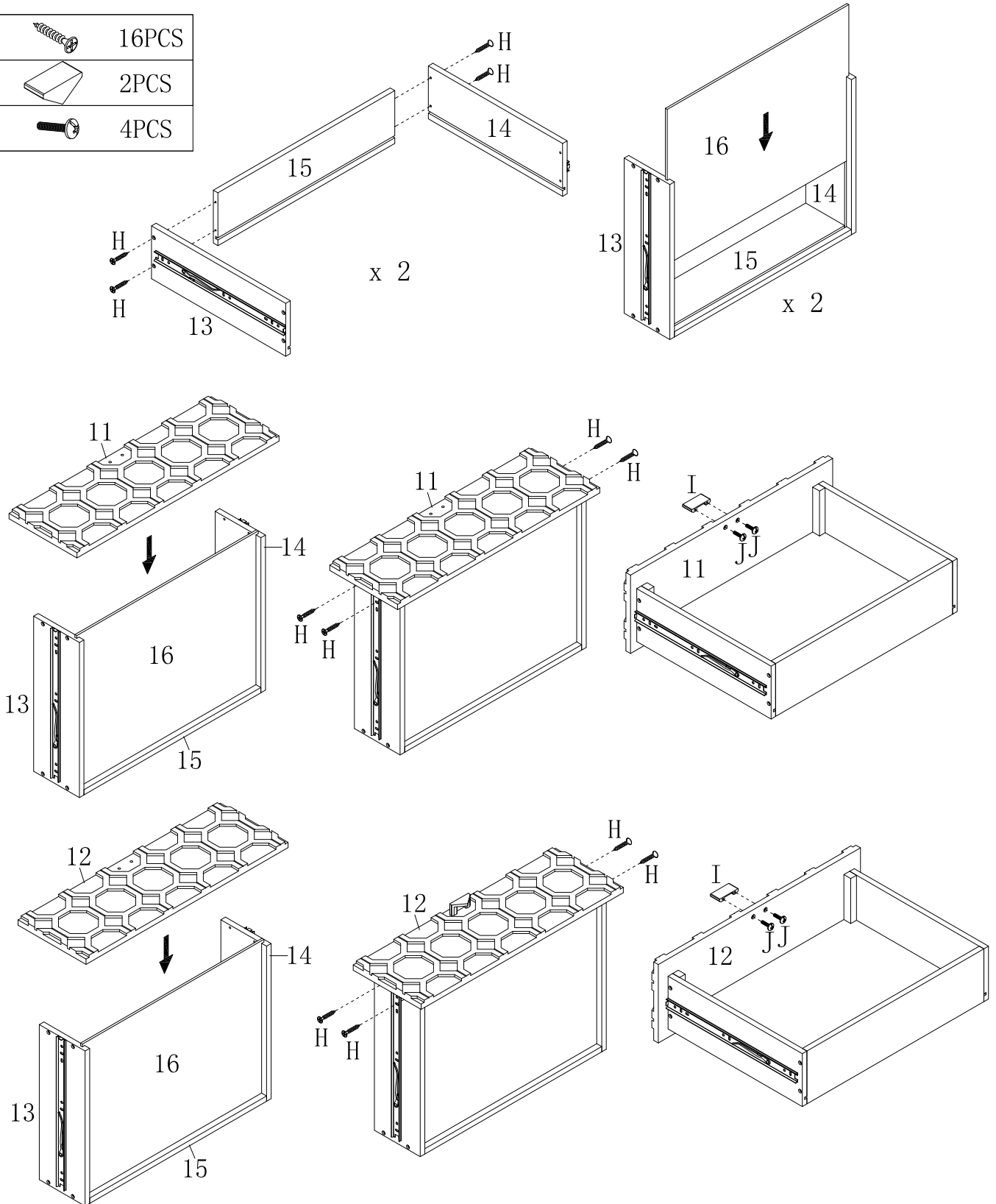

## STEP 1

H:		16PCS
I:		2PCS
J:		4PCS



# ASSEMBLY INSTRUCTION

## STEP 2

- |    |   |      |
|----|---|------|
| D: |  | 2PCS |
| G: |  | 1PC  |

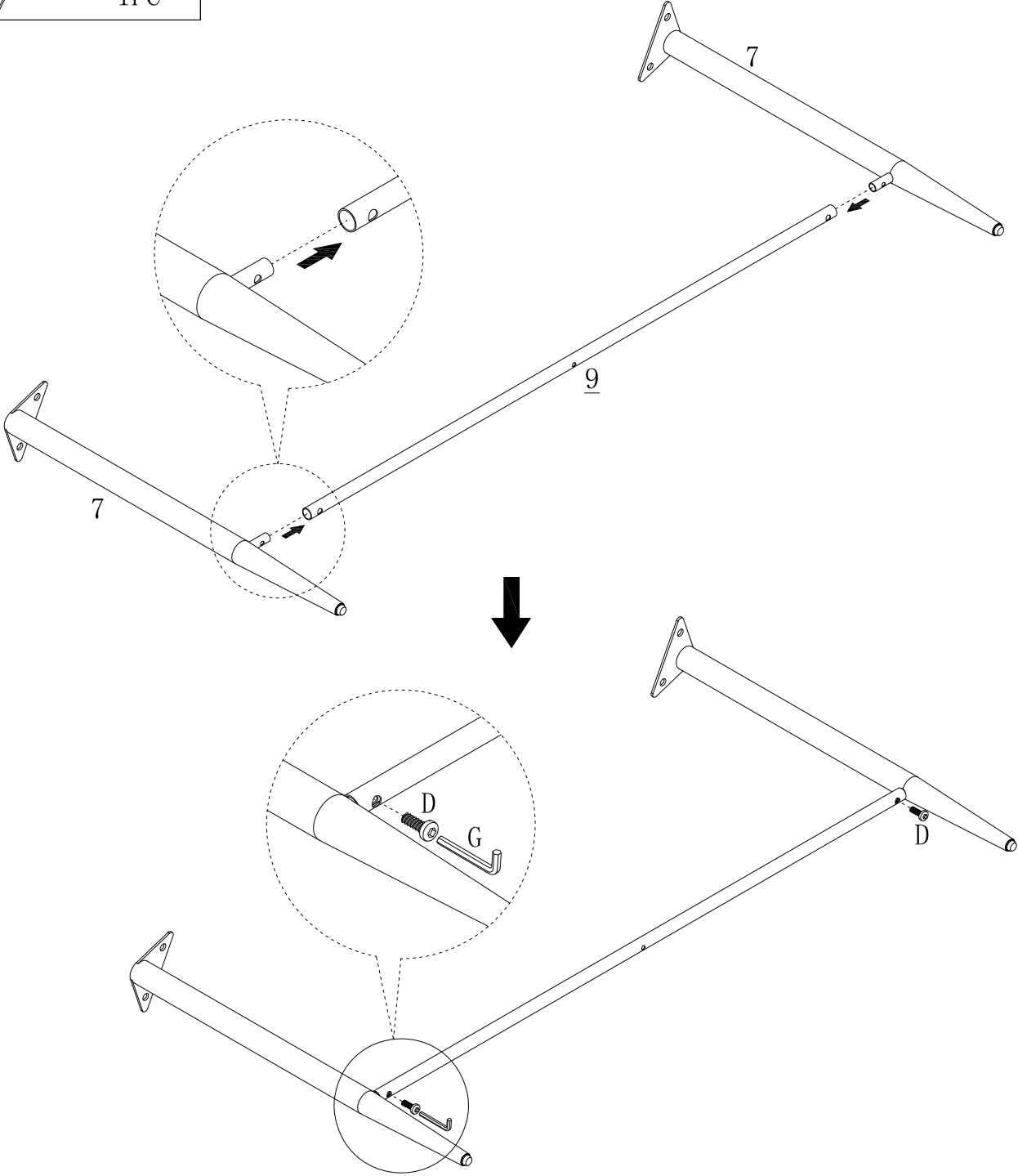



# ASSEMBLY INSTRUCTION

## STEP 3

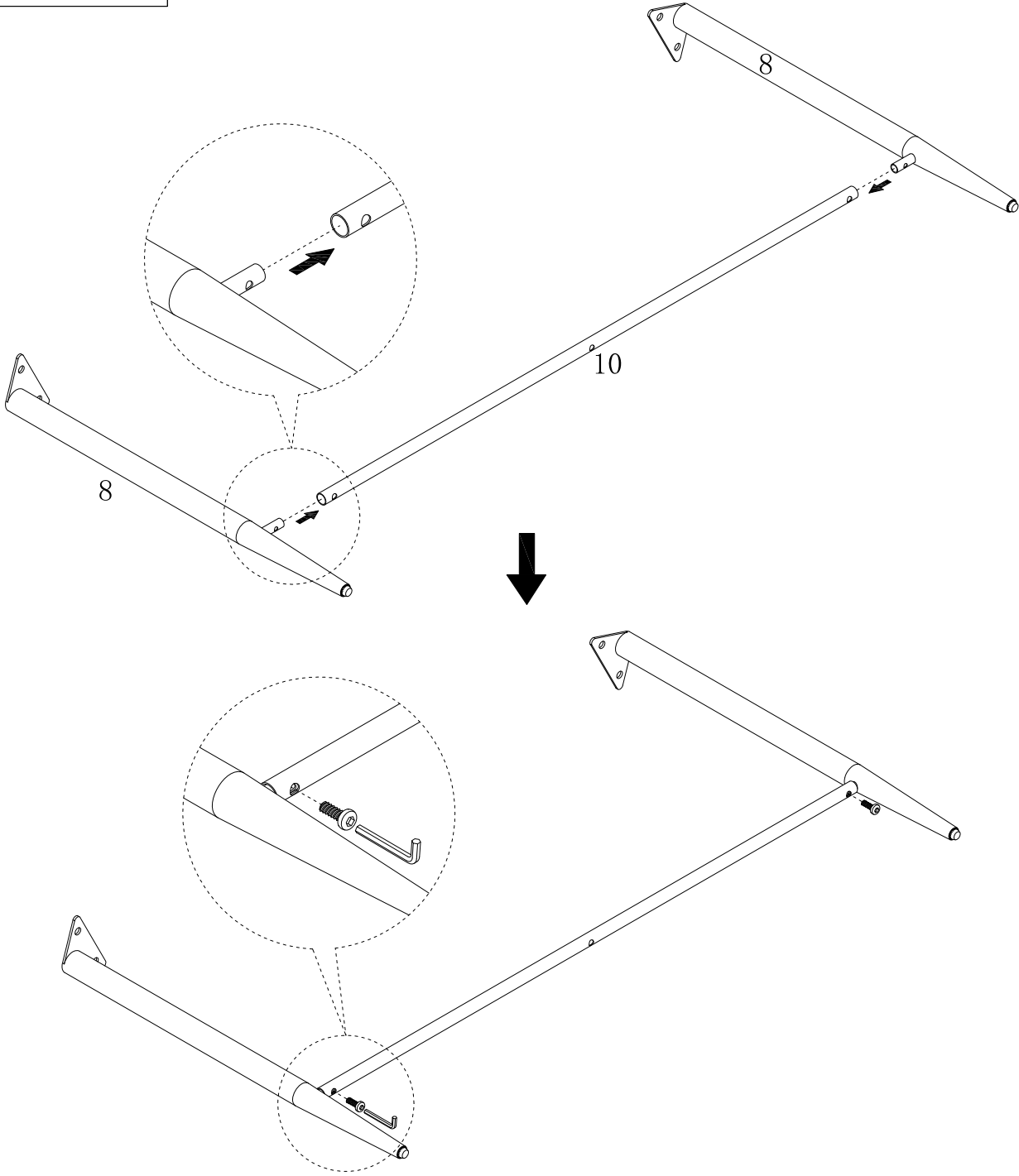
D:  2PCS



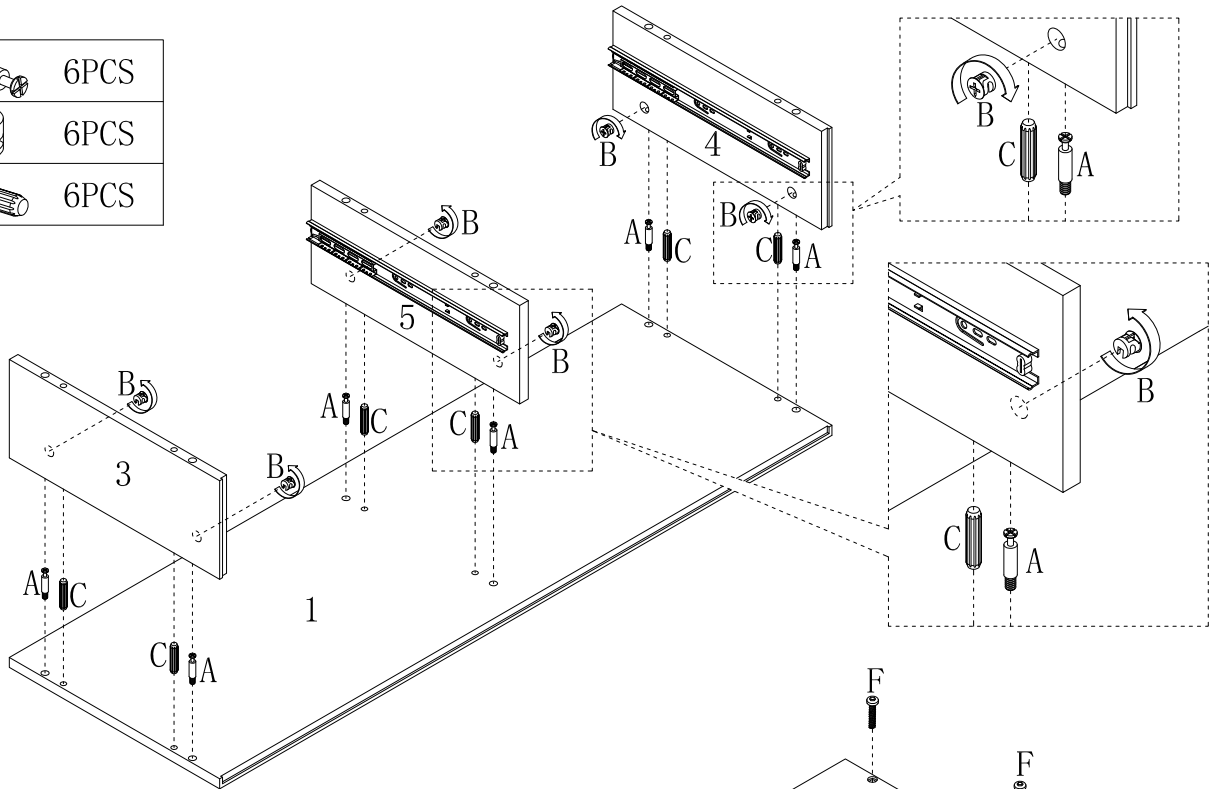

## STEP 4

A:		6PCS
B:		6PCS
C:		6PCS



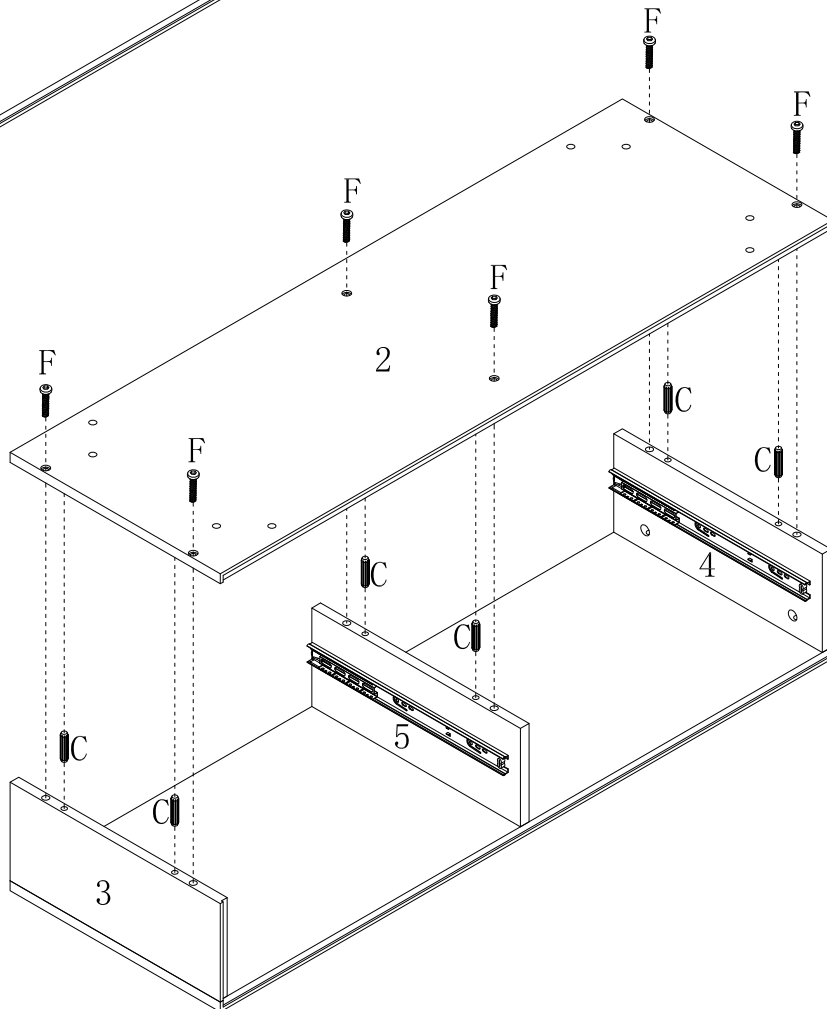

## STEP 5

C:		6PCS
F:		6PCS



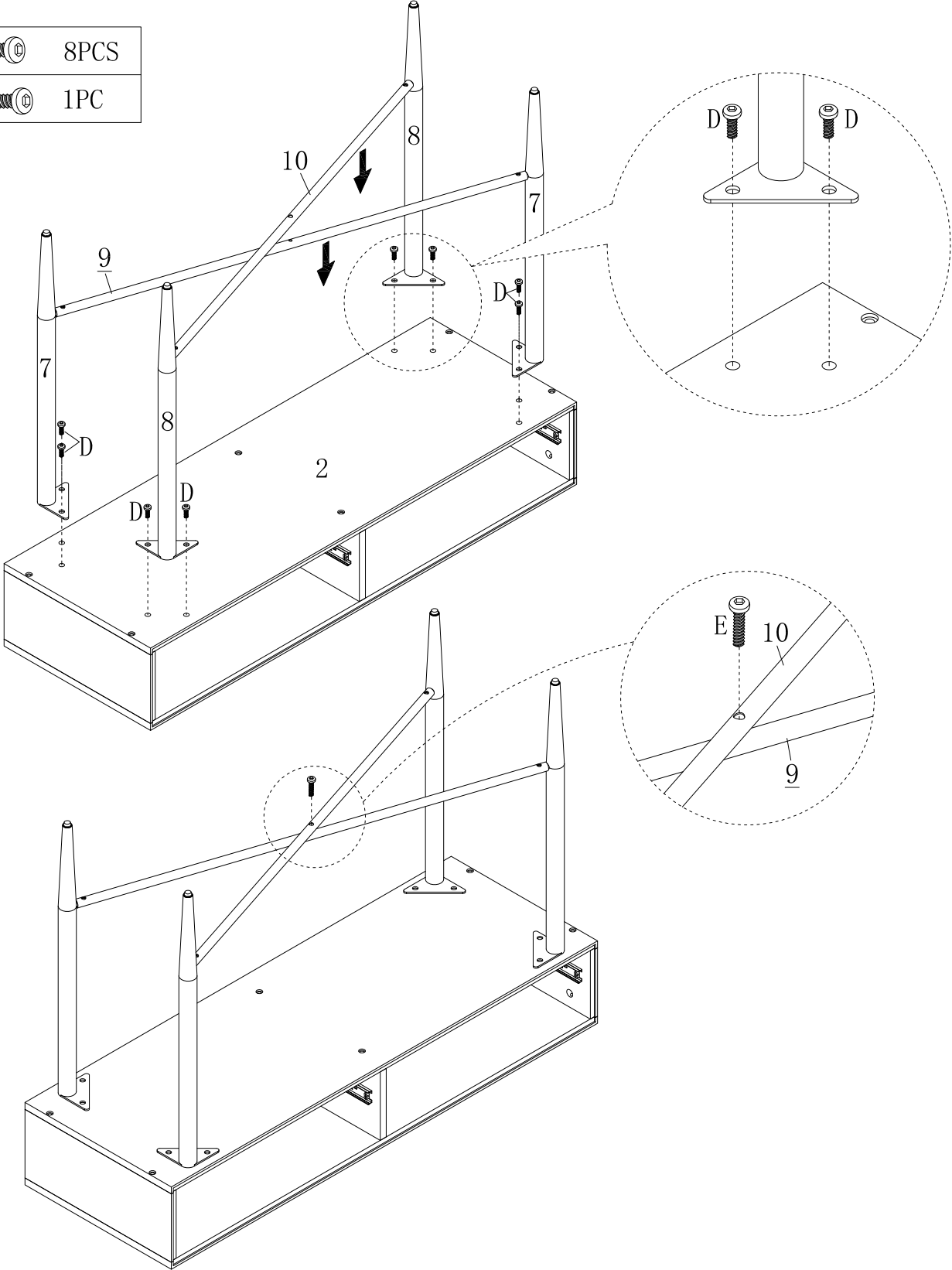

STEP 6

- |    |   |      |
|----|---|------|
| D: |  | 8PCS |
| E: |  | 1PC  |



STEP 7

K:		14PCS
L:		2PCS

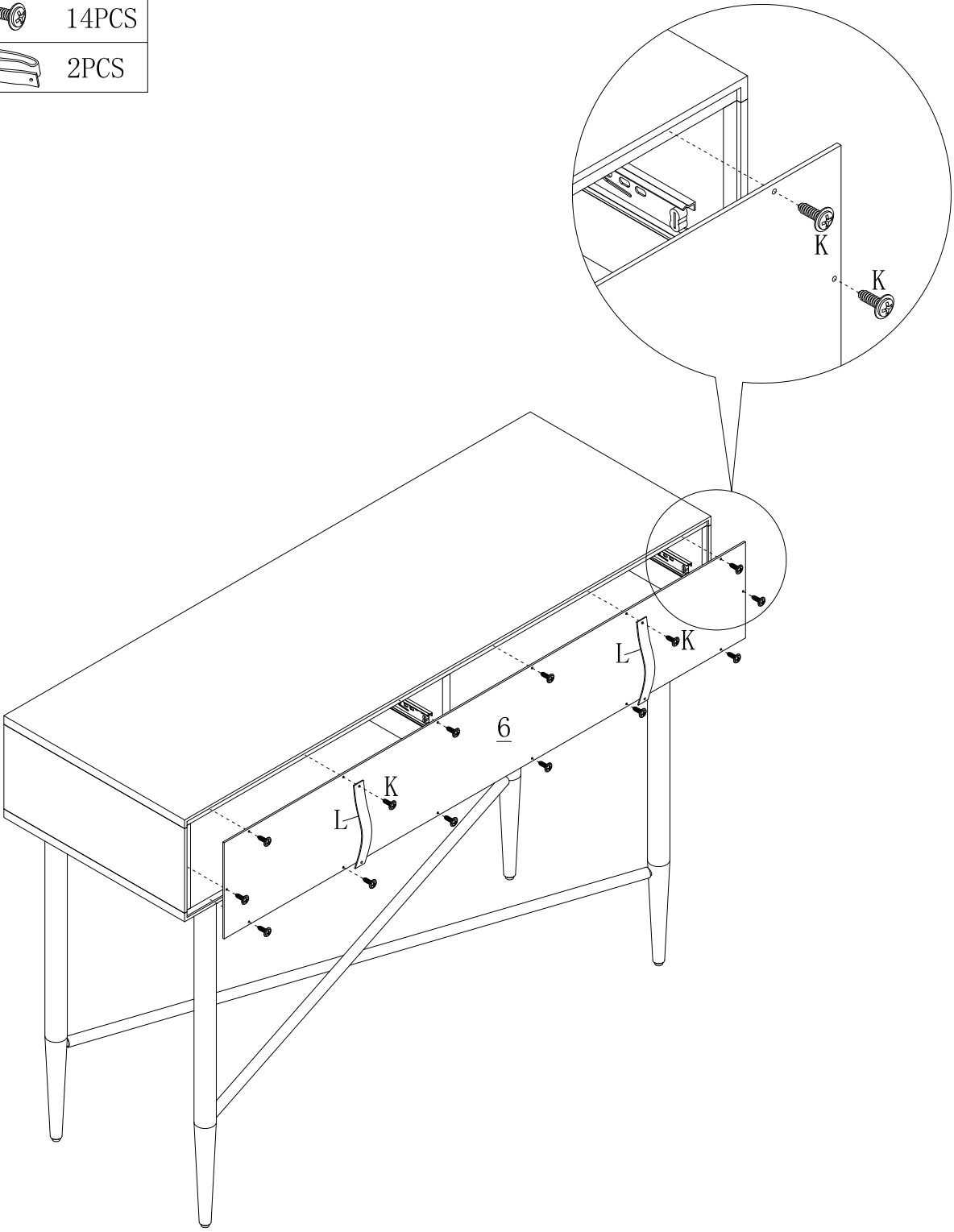

## STEP 8

Note: Place the slidable part to the front position before sliding in.

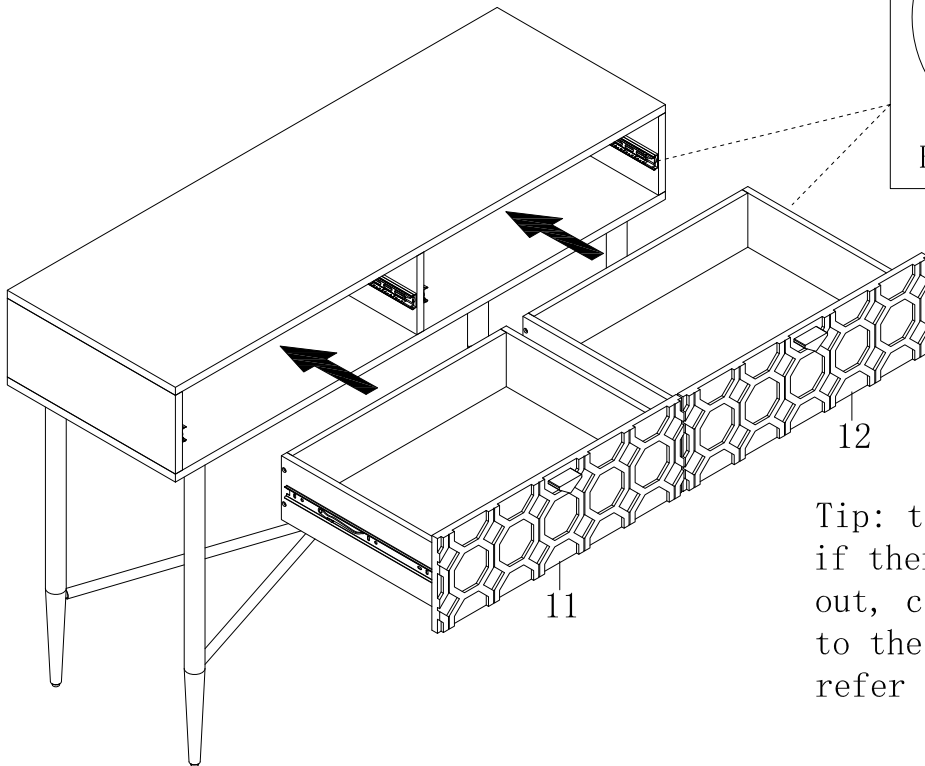
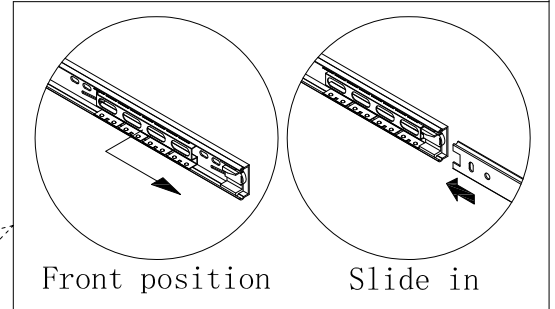

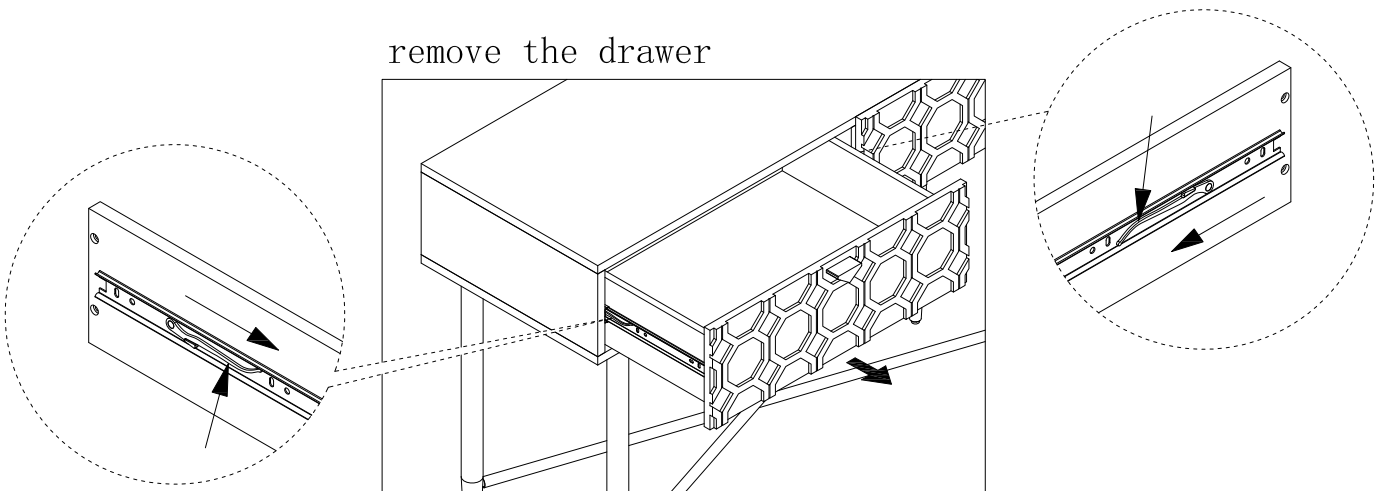

Tip: the front of the drawer, if there is tilt, do not force out, can be adjusted according to these two positions, please refer to the following steps.

remove the drawer

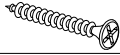

## STEP 9

M:		2PCS
N:		2PCS
O:		2PCS

For safety reasons, it is recommended to install safety wall strap to fix the item.

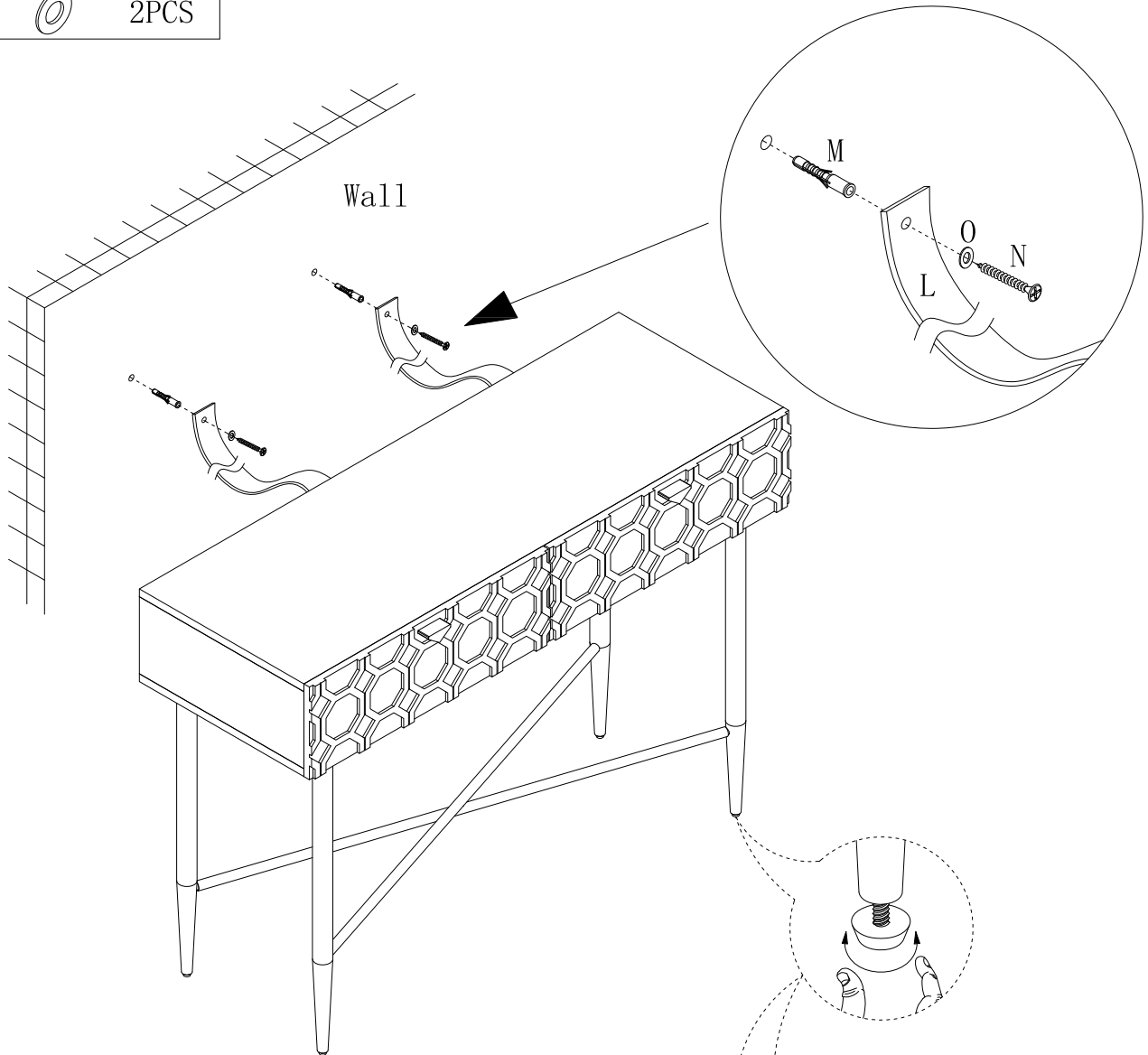

After installation, adjust the adjustable foot to keep the table balanced.