



36-INCH MONSTER KIDS TRAMPOLINE WITH HANDRAIL

MODEL# 9021MT
PRODUCT MANUAL - VERSION 5.21.01

FOR AGES:

3-7

WEIGHT LIMIT:

75 Lbs
34 Kgs

TO BUILD:

1 x 1

TOOLS NEEDED:

N/A



HOW-TO
VIDEOS ONLINE



Manual en español ubicado en GQBrands.com

Spanish Manual located at GQBrands.com

CUSTOMER SERVICE

GQBrands.com • CustomerService@GQBrands.com • 1-866-498-5269 • 4401 Samuell Blvd, Ste 150, Mesquite, TX 75149



PATENT PENDING*

CUSTOMER SERVICE INFORMATION

Thank you for purchasing: 36-INCH MONSTER KIDS TRAMPOLINE

MODEL# 9021MT

If you have an issue with your item, do not return. Please report items that are damaged or missing parts to the manufacturer GQ Brands within three days of delivery. Contact customer service at customerservice@gqbrands.com to open a ticket.

At GQBrands®, we want all of our customers to be completely satisfied with their purchase. Take time to review the contents of the product you have just received to make sure that all of the parts are included. If you find that any parts are missing or damaged, we will provide replacement parts at no charge within 30 days of purchase.

Please keep in mind that for select damaged part replacement requests, we will require a photo for submission.

Please Note: In the interest of better quality and value, we are constantly improving and updating our product information. Most up to date manuals, warnings and product information can be found at: <https://www.globalqualitybrands.com/warnings>

To register your product please visit:
www.globalqualitybrands.com/product-registration
or Scan code



To order these parts, or if you have any other questions or concerns about this GQBrands product, please contact us at

PureFun.Net
GQBrands®
Phone: 1-866-498-5269
Email: CustomerService@GQBrands.com
4401 Samuell Blvd, Ste 150, Mesquite, TX 75149

Please be sure to include the following information when you contact Customer Service:

YOUR NAME: _____

YOUR MAILING ADDRESS: _____

YOUR EMAIL ADDRESS: _____

PRODUCT NAME: _____

PRODUCT MODEL#: _____

PART NUMBER _____

RETAILER WHERE PURCHASED: _____

DATE OF PURCHASE: _____

ORDER NUMBER: (If Available) _____

QUANTITY NEEDED: _____

SERIAL NUMBER: _____

LIMITED WARRANTY

Global Quality Brands® warrants this product to be free from defects in workmanship and materials under normal use and conditions for a period of:

**6 MONTHS - STEEL FRAME
90 DAYS - ALL OTHER PARTS**

This Limited Warranty is not transferable and is available only for the original purchaser of the Product. The Company's obligation under this warranty is limited to replacing or repairing the Product, at the discretion of the company.

All warranty coverage extends only to the original retail purchaser from the date of purchase. GQ Brands obligation under this warranty is limited to replacing or repairing, at Global Quality Brands® option. All products for which a warranty claim is made must be received by Global Quality Brands® and accompanied by sufficient proof of purchase (photocopy of the original store receipt, indicating the date of purchase). All freight and handling fees are the responsibility of the consumer to pay, both to and from Global Quality Brands®. All warranty claims must be pre-authorized by Global Quality Brands® pre-authorization can be obtained by calling 866-498-5269.

This warranty does not cover ordinary wear and tear, weathering, failure to follow directions, improper installation, improper maintenance, or acts of nature, (such as damage caused by wind, lightning, snow, water, or ice) weather damage, damage caused by unauthorized repair work or damage caused by improper use of the products are not covered by the product warranty. No other warranty beyond that specifically set forth above is authorized by GQBrands®.

GLOBAL QUALITY BRANDS® IS NOT RESPONSIBLE OR LIABLE FOR INDIRECT, SPECIAL OR CONSEQUENTIAL DAMAGES ARISING OUT OF OR IN CONNECTION WITH THE USE OR PERFORMANCE OF THE PRODUCT OR OTHER DAMAGES WITH RESPECT TO ANY ECONOMIC LOSS, LOSS OF PROPERTY, LOSS OF REVENUE OR PROFITS, LOSS OF ENJOYMENT OR USE, COST OF REMOVAL, INSTALLATION OR OTHER CONSEQUENTIAL DAMAGES. SOME STATES DO NOT ALLOW THE EXCLUSION OR LIMITATION OF INCIDENTAL OR CONSEQUENTIAL DAMAGES. ACCORDINGLY,

THE ABOVE LIMITATION MAY NOT APPLY TO YOU. THE WARRANTY EXTENDED HEREUNDER IS IN LIEU OF ALL OTHER WARRANTIES AND GLOBAL QUALITY BRANDS®, SPECIFICALLY DISCLAIMS ANY IMPLIED WARRANTY OF MERCHANTABILITY OR FITNESS FOR A PARTICULAR PURPOSE IS LIMITED IN ITS SCOPE AND DURATION TO THE TERMS SET FORTH HEREIN. SOME STATES DO NOT ALLOW LIMITATION ON HOW LONG AN IMPLIED WARRANTY LASTS. ACCORDINGLY, THE ABOVE LIMITATION MAY NO APPLY TO YOU. THIS WARRANTY GIVES YOU SPECIFIC LEGAL RIGHTS. YOU MAY ALSO HAVE OTHER RIGHTS, WHICH VARY FROM STATE TO STATE.

WHILE EVERY ATTEMPT IS MADE TO ENSURE THE HIGHEST DEGREE OF PROTECTION IN ALL EQUIPMENT, WE CANNOT GUARANTEE FREEDOM OF INJURY. THE USER ASSUMES ALL RISK OF INJURY DUE TO USE OR INSTALLATION. ALL MERCHANDISE IS SOLD ON THIS CONDITION, WHICH NO REPRESENTATIVE OF GQ BRANDS® CAN WAIVE OR CHANGE.



IMPORTANT MESSAGE

Please read all of the warnings and directions below prior to assembly. This trampoline comes equipped with warnings and instructions for the assembly, care, maintenance and use of the trampoline. This information must be read by all trampoline supervisors and users before any person is allowed to jump on the trampoline.

ADULT ASSEMBLY REQUIRED
CHOKING HAZARD - Small Parts
NOT for children under 3 years of age.

WARNING:

While every attempt is made to ensure the highest degree of protection in all equipment, we cannot guarantee freedom from injury. The user assumes all risks of injury due to use and installation. All merchandise is sold on this condition, which no representative of the company can waive or change.

⚠ PROPOSITION 65

THIS PRODUCT CAN POSSIBLY EXPOSE YOU TO CHEMICALS INCLUDING DI(2-ETHYLHEXYL) PHTHALATE (DEHP), WHICH IS KNOWN TO THE STATE OF CALIFORNIA TO CAUSE CANCER AND BIRTH DEFECTS OR OTHER REPRODUCTIVE HARM. FOR MORE INFORMATION GO TO WWW.P65WARNINGS.CA.GOV.

⚠️ WARNING LABEL LOCATIONS

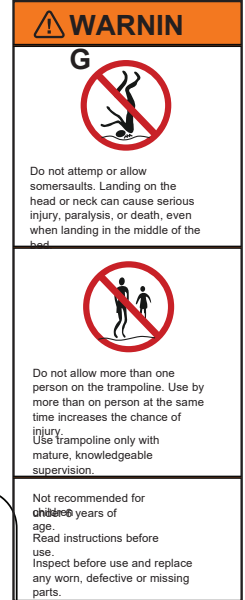
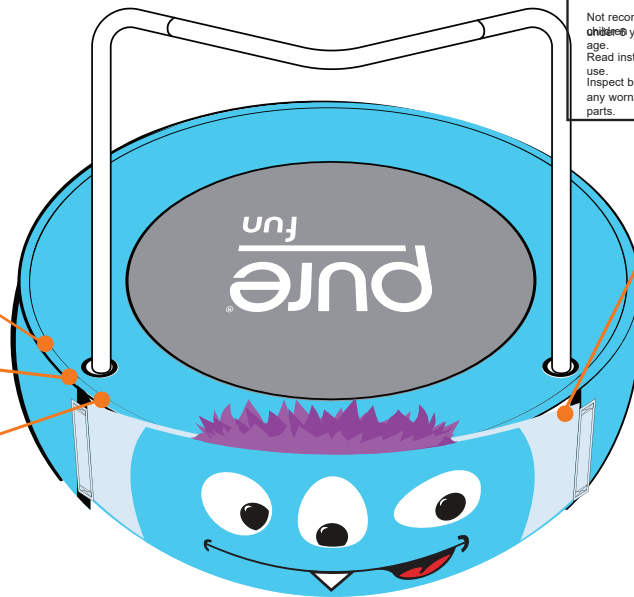
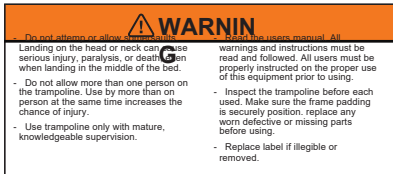

The labels shown on this page have been attached to the trampoline in the indicated location

Note: The labels are not shown actual size.



WARNINGS & SAFETY INFORMATION

Please read these warnings and the information in this manual in its entirety.

Failure to comply with the following instructions may increase the risk of serious injury and/or death:

- The owner and supervisors of this trampoline are responsible to make sure all users are aware of the warnings and use specified in this manual.
- Ensure the trampoline has been assembled correctly, per the instructions in the manual.
- It is essential that the intended site for this trampoline is completely flat and level. If the ground is not level this will cause movement in the frame and could cause stress on the joined sections.
- It is only recommended for use by children ages 3 to 7 years.
- The contents are not suitable for children under 3 years. This product contains small parts, which may cause choking.
- Use this trampoline only with mature, knowledgeable supervision.
- DO NOT exceed the recommended MAXIMUM WEIGHT limit of 75 lbs.
- DO NOT allow more than one person on the trampoline at a time.
- DO NOT wear glasses or helmets when using the trampoline.
- DO NOT use the trampoline in wet, windy or other adverse weather conditions. Use only when the trampoline mat is clean, dry, and safe of obstructions.
- DO NOT somersault or perform flips. This can cause serious injury, resulting in paralysis or death.
- DO NOT use the trampoline as a springboard to or from other objects. NEVER jump from or attempt to jump to other objects, bodies of water, buildings or surfaces, or into or over the trampoline enclosure.
- DO NOT jump on the trampoline while holding an object, particularly on that is sharp or breakable.
- ALWAYS remove jewelry, belt buckles or any other sharp objects before using the trampoline.
- ALWAYS jump in the center of the trampoline mat.
- ALWAYS secure the trampoline against unauthorized and unsupervised use.
- This trampoline is designed only for jogging in place and similar bounding exercises.
- Caution and care must be taken underneath a light fixture or ceiling fan.
- Adequate overhead clearance is essential. A minimum of 8ft from ground level is recommended.
- Lateral clearance is essential. Place the trampoline away from walls, structures, fences and other areas. Maintain a clear space on all sides of the trampoline.
- Children MUST NEVER use the trampoline unless supervised by a responsible adult with knowledge of trampoline use. DO NOT leave children unattended at any time.
- Immediately discontinue use if any breakage to the frame assembly or springs are found. Failure to do this may result injury and/or further damage to the product.
- This trampoline is only designed for normal residential use. It is NOT intended for commercial applications and/or in public areas such as schools, parks, day cares, commercial/communal gyms, etc. as such use will void the warranty.
- Misuse and abuse of the trampoline is dangerous and can cause serious injuries.
- Step onto and off of the trampoline. Do not jump onto or off of it. Do not sue the trampoline as a springboard to other objects.
- Injury may result from hitting the frame or falling through the springs while jumping. Always stay in the center of the jump mat while jumping. Do not use the trampoline without the frame pad securely in place fully covering the frame and springs.
- The trampoline frame pad is not designed or intended to support the weight of the user. Do not step or jump directly onto the frame pad.
- The frame of your trampoline is made of steel and it will conduct electricity. No electrical equipment (lights, heaters, etc.) should be permitted on or around the trampoline under any circumstance.
- The trampoline is a rebounding device that propels the user to unaccustomed heights and into a variety of body movements. Rebounding off the trampoline, striking the frame or springs or improperly landing on the jump mat may cause injury.
- Before each use of this product, inspect the entire assembly and replace any worn, defective or missing parts.
- No modification should be carried out to the trampoline or any of its components. Any modification could lead to damage to the product or result in a personal injury.
- Please read and refer to other warnings and use information in the trampoline instructions before use.
- Owners shall be responsible for maintaining the legibility of the warning labels.
- Dispose of all packaging materials safely and per local ordinance.
- Keep this manual and instructions for future reference.

BASIC TRAMPOLINE SKILLS

The following exercises are examples of instructions for use of this exercise trampoline. It is highly recommended to stretch and warm up for at least 10 minutes before starting any exercise. Jumpers should practice these basic techniques and perfect them.

Jumping Jacks

1. Stand with your feet together and your arms alongside your body.
2. Lift your arms overhead as you jump your feet apart.
3. Then jump back to the starting position.
4. Continue for 1 to 3 minutes.

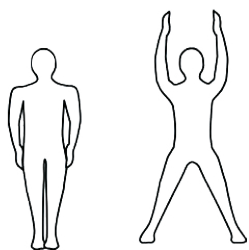

Tuck Jumps

1. From standing, jump up and tuck your knees into your chest.
2. Upon landing, do a recovery jump. Once you get the hang of it, you can do a tuck with every jump.
3. Continue for 1 to 3 minutes.

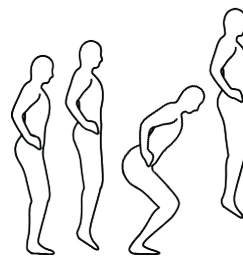

Twists

1. Stand with your feet directly under your hips and your arms alongside your body.
2. Jump up and turn your legs to the left as you rotate your upper body to the right.
3. Return to the starting position upon landing.
4. Then jump up and turn your legs to the right as you rotate your upper body to the left.
5. Do 1 to 3 sets of 8 to 16 repetitions.

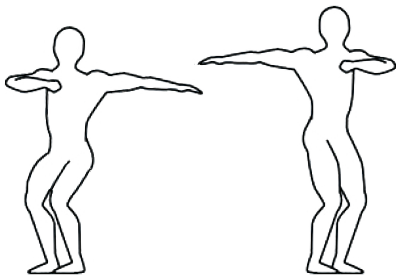

Jogging

1. Stand with your spine straight or lean back slightly.
2. Lift your knees in front of you to jog in place.
3. Pump your opposite arms.
4. Continue for 1 to 4 minutes.

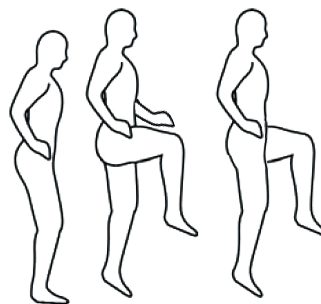

PARTS LIST

1- Fold Mat and Frame

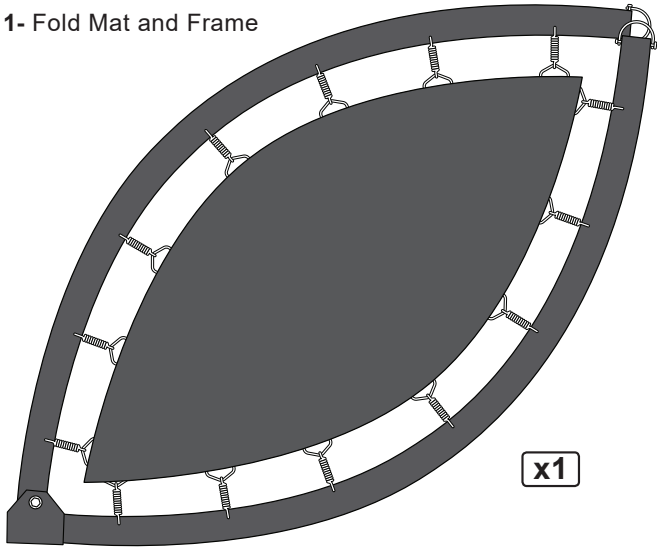

2- Frame Pad

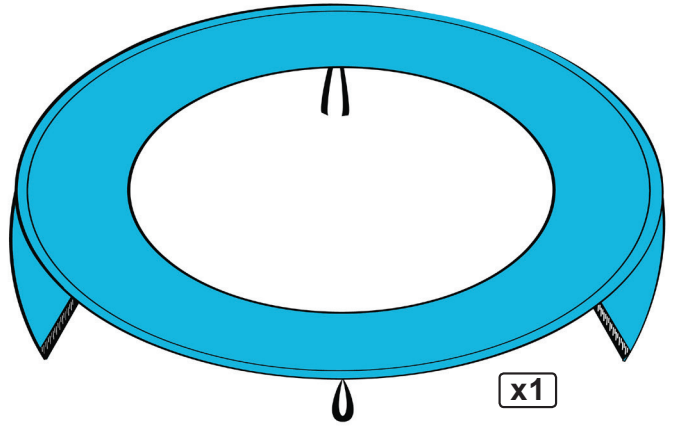

3- Plush Face

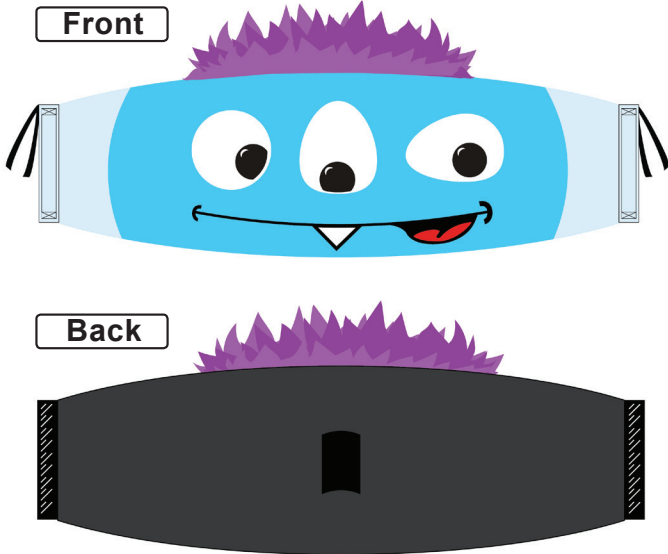

4- Side Handrail

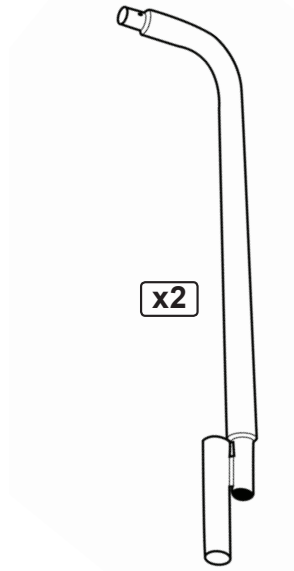

5- Center Handrail

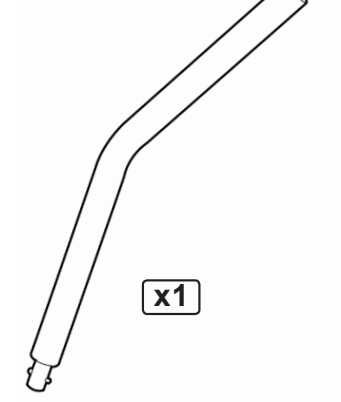

6- Safety Hook

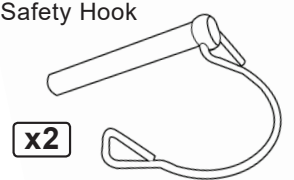

7- Leg

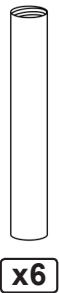

8- Leg Cap

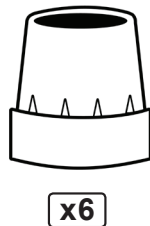

9- Frame Cap

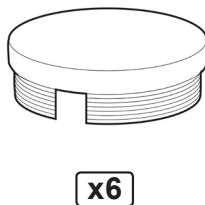

10- Springs

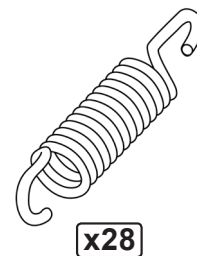

11- Monster Feet Pair



ASSEMBLY INSTRUCTIONS

To assemble the trampoline properly, you must follow all instruction steps below. Do not attempt to alter any trampoline frame components or parts or skip any steps below. Use gloves to protect your hands from pinch points during assembly.

STEP 1

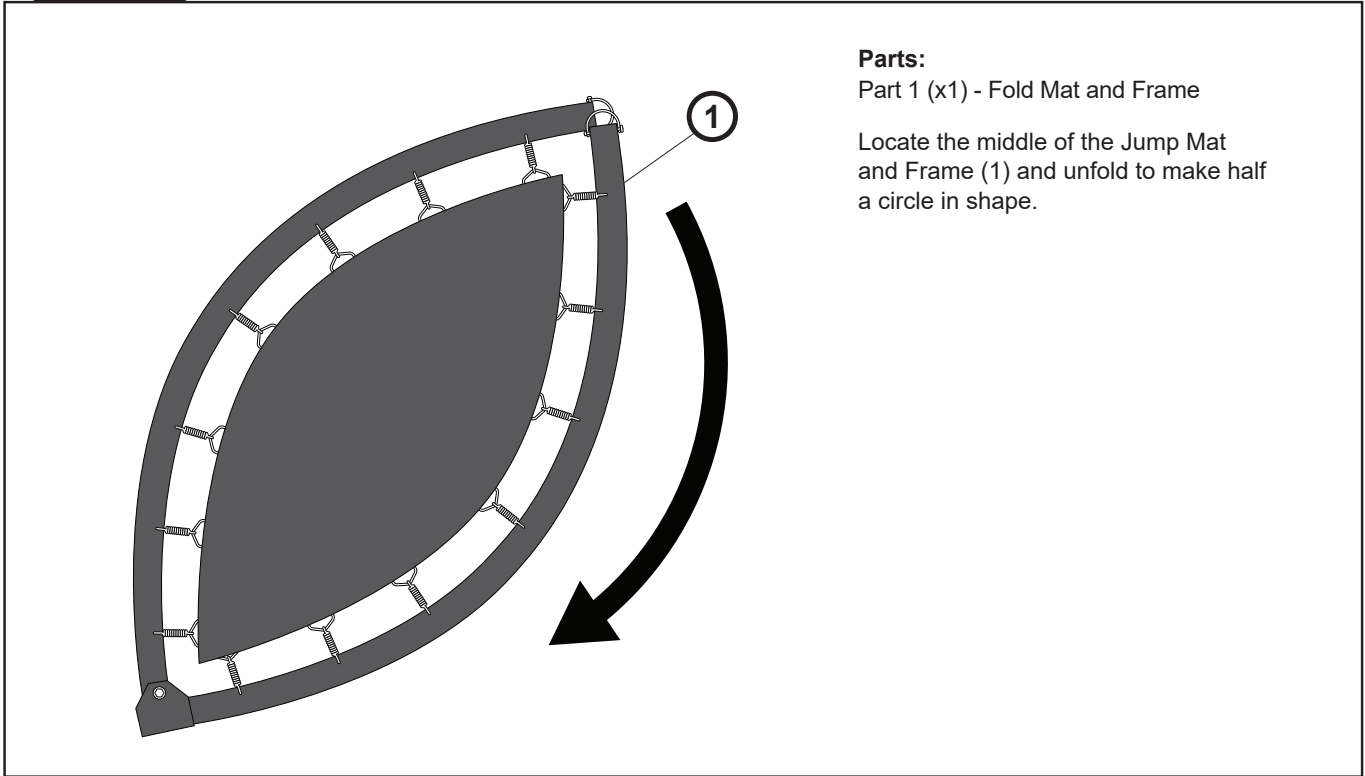

Parts:

Part 1 (x1) - Fold Mat and Frame

Locate the middle of the Jump Mat and Frame (1) and unfold to make half a circle in shape.

STEP 2

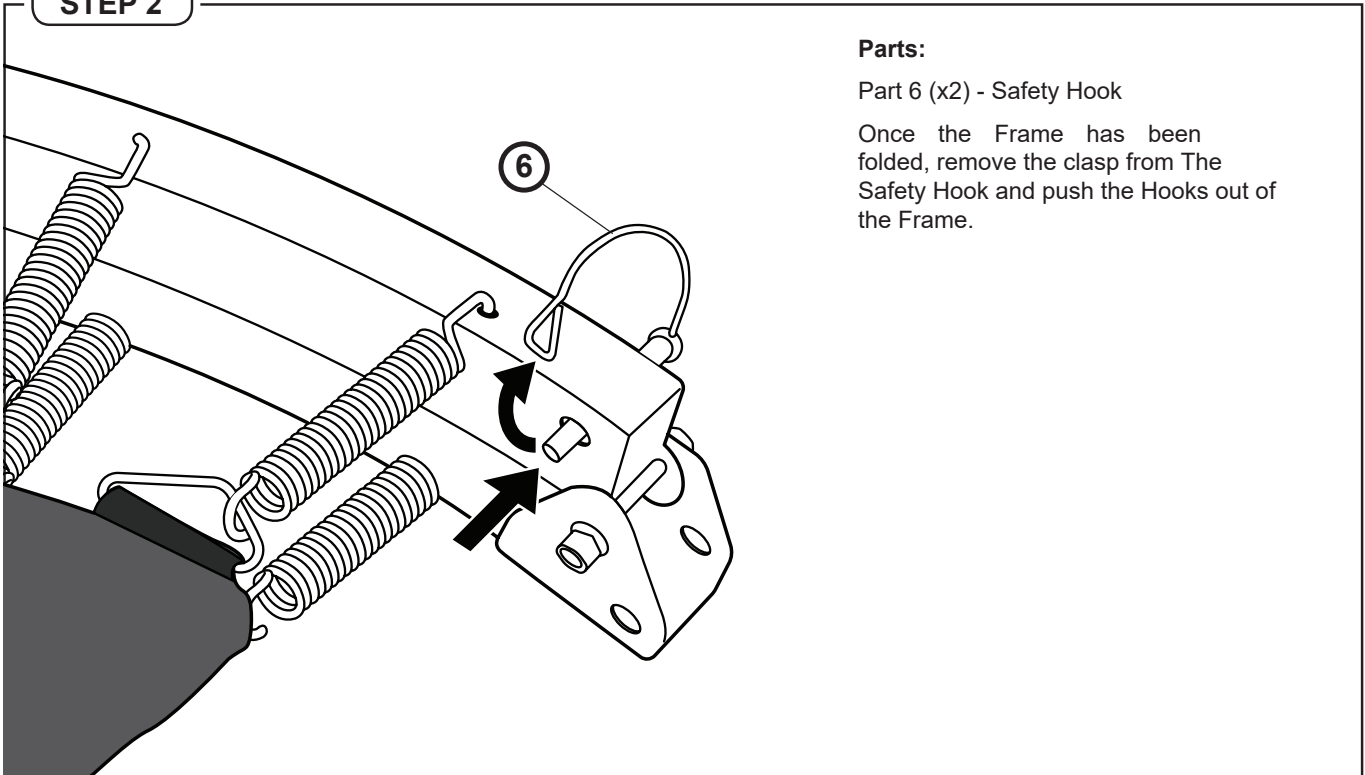

Parts:

Part 6 (x2) - Safety Hook

Once the Frame has been folded, remove the clasp from The Safety Hook and push the Hooks out of the Frame.

ASSEMBLY INSTRUCTIONS

STEP 3

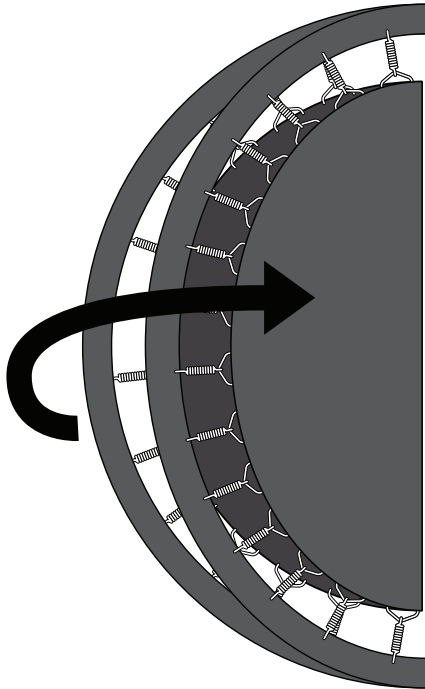

Apply weight to one side of the Jump Mat and unfold to complete the circle.

NOTE:

Make sure to keep applying pressure to the Frame to avoid tension to close the frame. Failure to do so can cause injury.

STEP 4

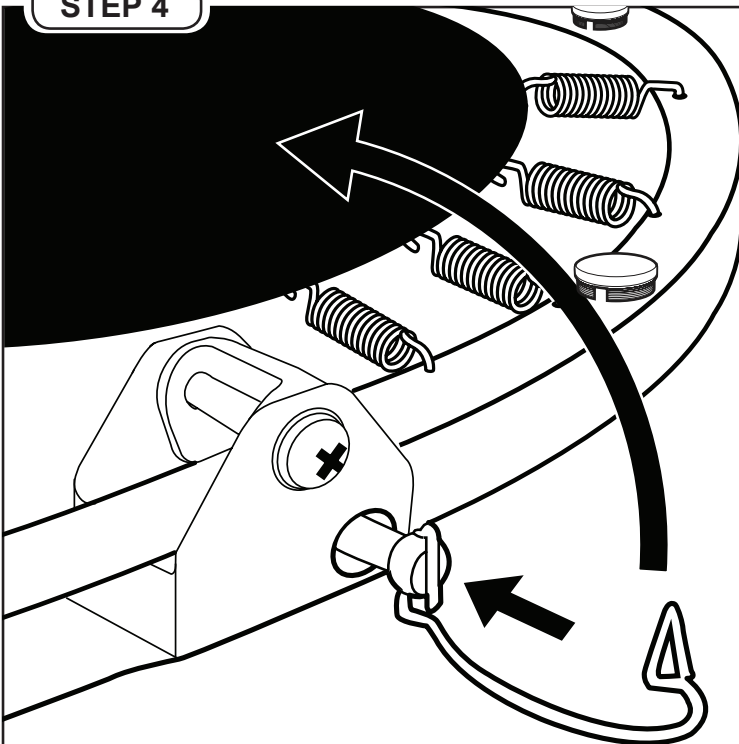

Once the Mat is Completely unfolded and the Jump Mat is Stretched out properly, place the Safety Hooks (6) back on both brackets.

Make sure the Safety Hooks are completely inserted, and use the clasp to secure the Frame Pad from Unfolding.

ASSEMBLY INSTRUCTIONS

STEP 5

9- Frame Cap

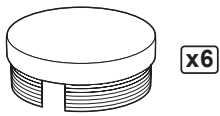

Remove all Frame Caps (9) from the Jumping Mat and Folding Frame.

This will expose the screws to insert the Legs (7) into in Step 6.

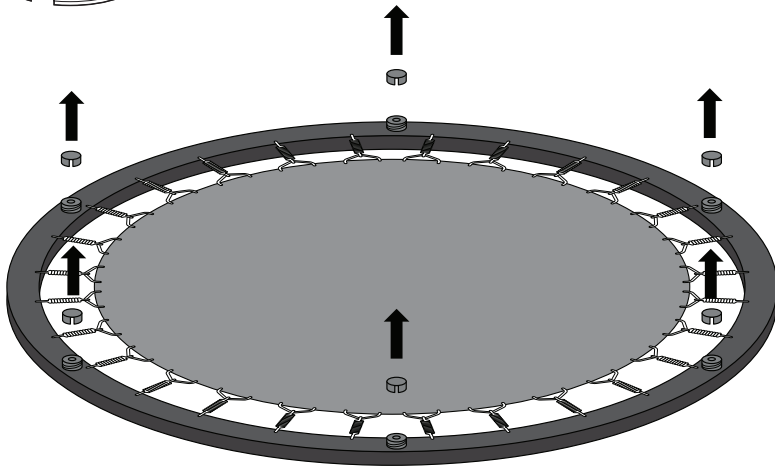

STEP 6

7- Leg

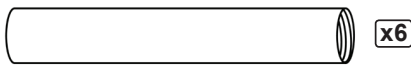

8- Leg Cap

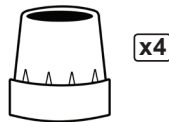

Grab 4x Legs (8A) and insert 4x Leg Caps (8B) to create 4 Assembled Legs. You will have 2 legs that do not need Leg Caps until Step 7.

Twist the Legs into the 6 exposed screws in the Frame.

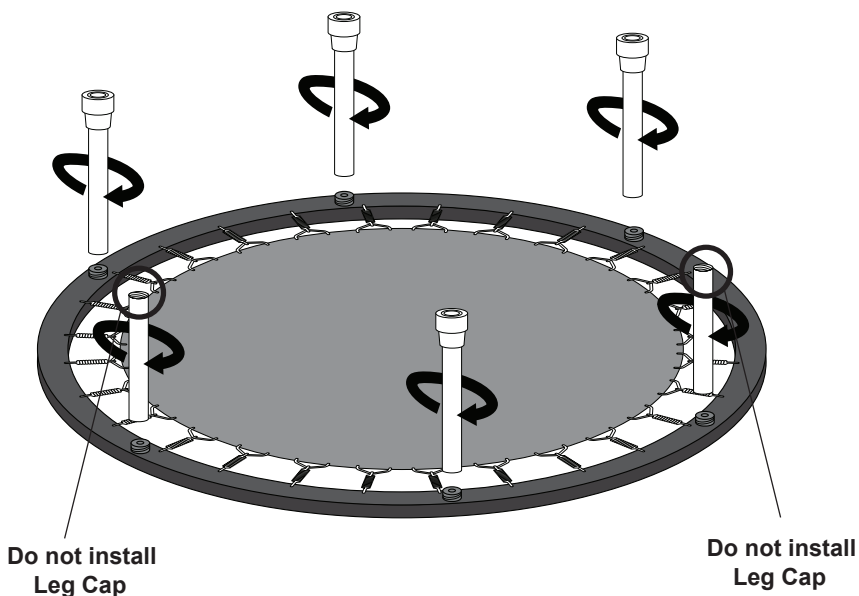

ASSEMBLY INSTRUCTIONS

STEP 7

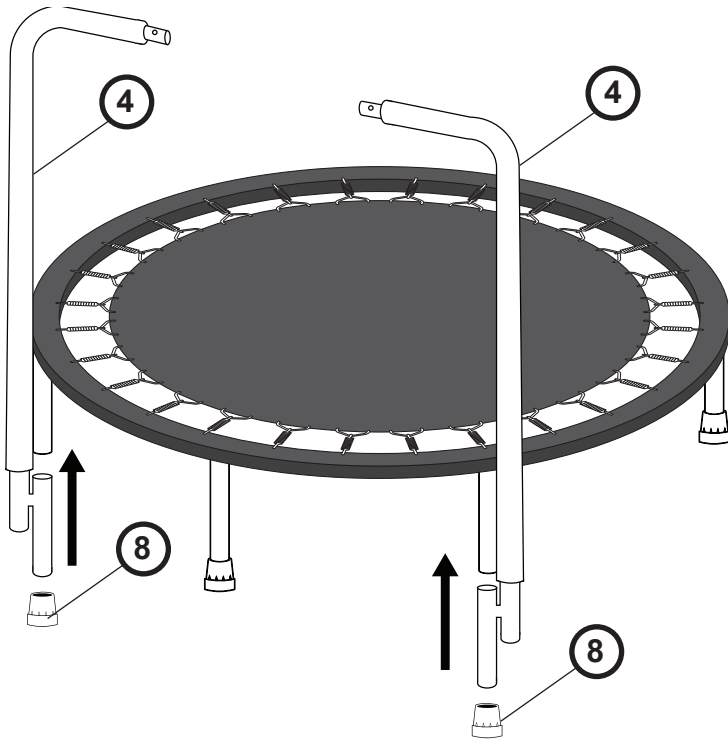

Flip the Trampoline over so that the legs are facing the floor.

Slide a Side Handle Rail (4) on each of the Legs without Leg Caps and secure with the remainder of the Leg Caps.

Make sure that both Side Hand Rails Are facing each other.

STEP 8

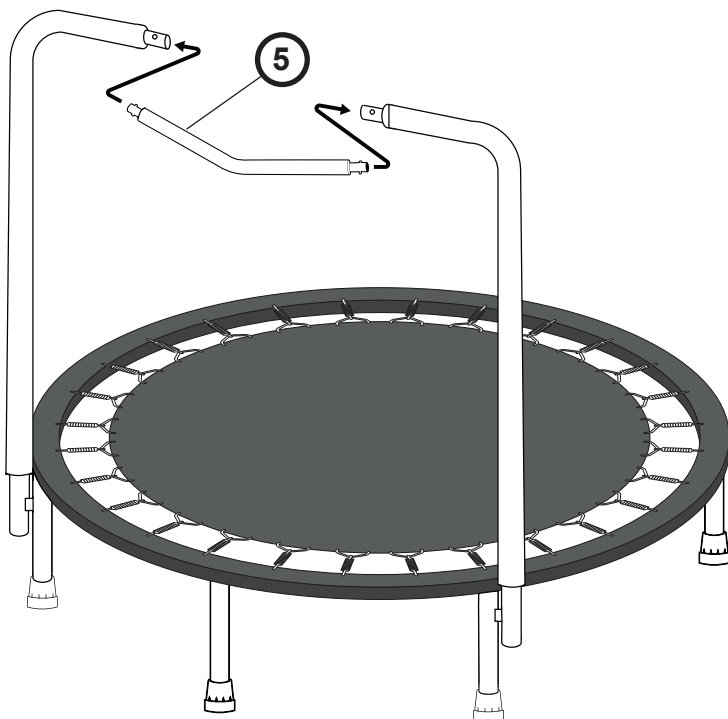

Insert the Center Handrail (5) in between both Side Handrails and use the Snap and Click buttons to secure.

Make sure that the curved end is pointing outward and giving space for the trampoline to show.

Once Installed, Slide the foams until they meet to avoid pinching while jumping.

ASSEMBLY INSTRUCTIONS

USING SNAP & CLICK BUTTONS

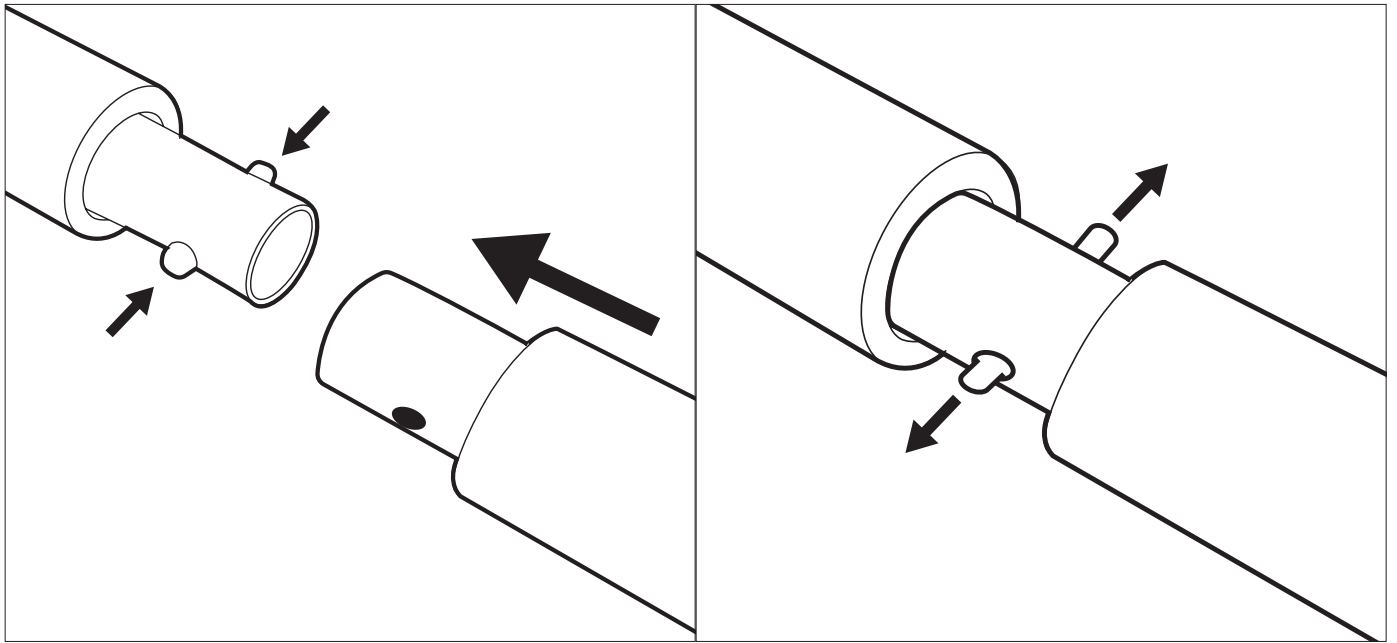

STEP 9

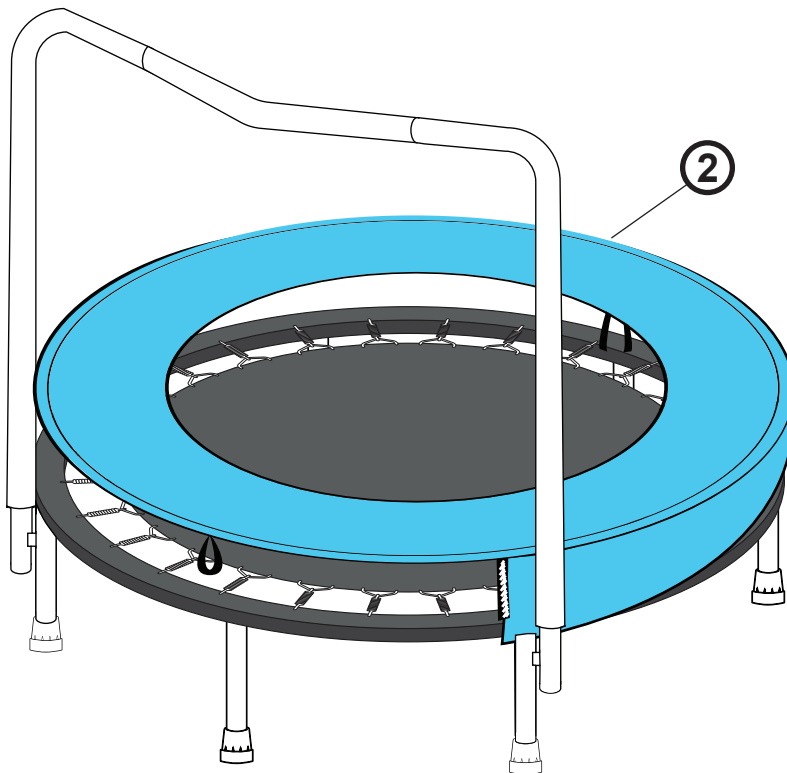

Place the Frame Pad (2) on top of the Trampoline so that the soft texture is facing upwards.

Align the front Loop in the exposed area of the Frame Pad to the front Leg and Handrail of the Trampoline.

ASSEMBLY INSTRUCTIONS

STEP 10

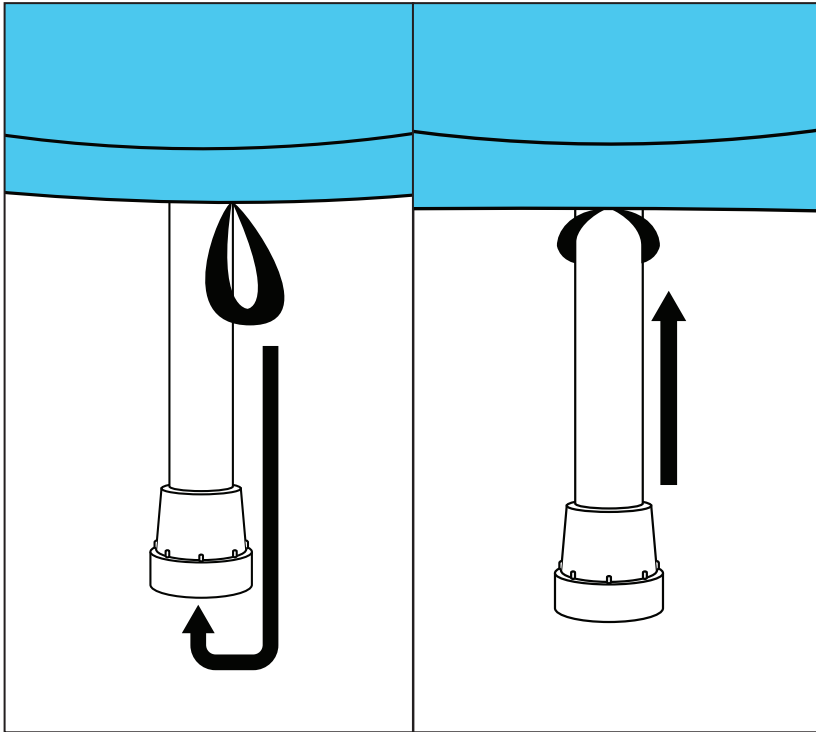

Pull the Loop on front of the Frame Pad and stretch it until it is hooked to the Leg.

STEP 11

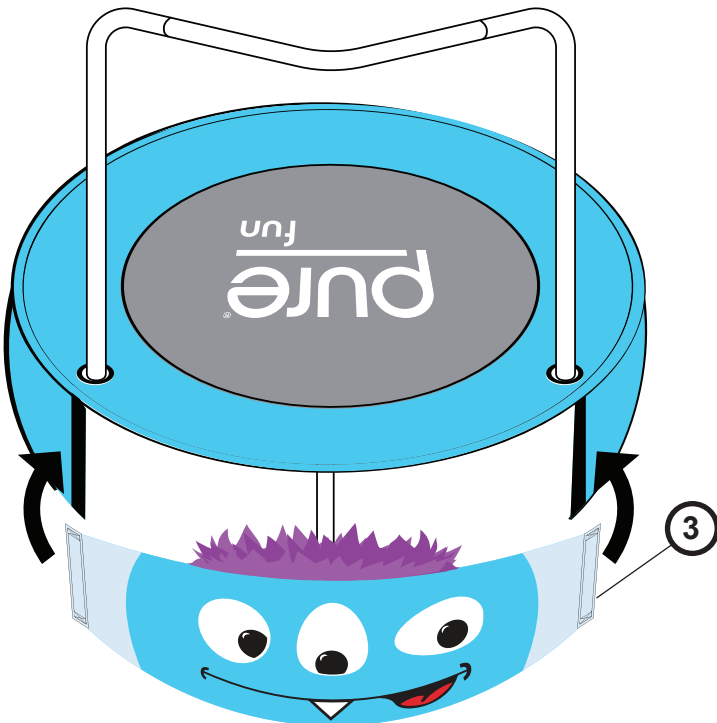

Attach the Plush Pillow (3) to the exposed Velcro straps on the Frame pad.

Align both Velcro straps to their respective sides with the face of the Plush facing outward.

ASSEMBLY INSTRUCTIONS

STEP 12

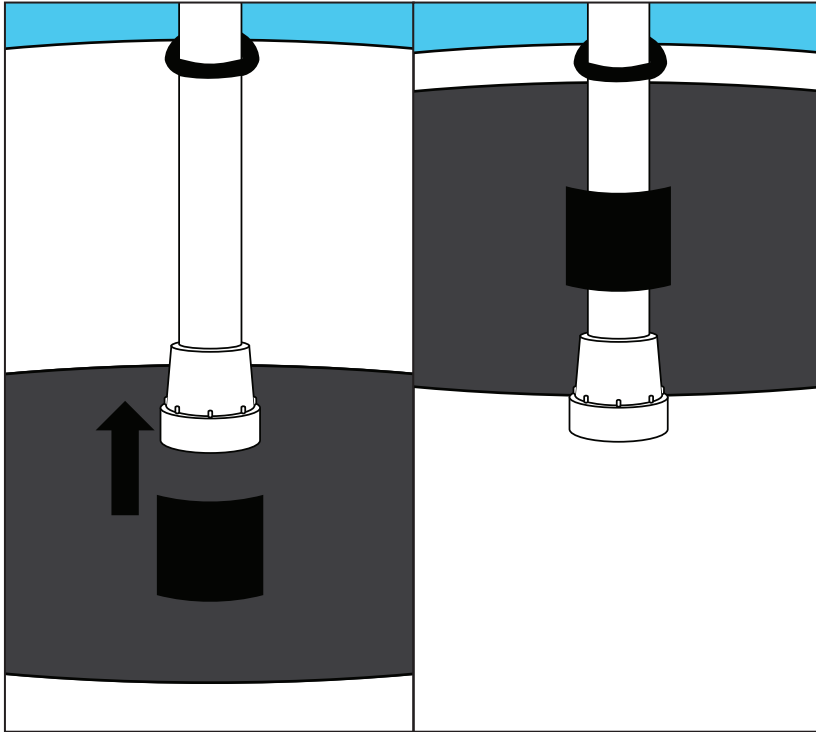

On the back of the Plush Face there is a Hook Strap that must be inserted in the front leg of the Trampoline.

Slide the Hook from the bottom of the Leg until it passed the Leg Cap.

STEP 13

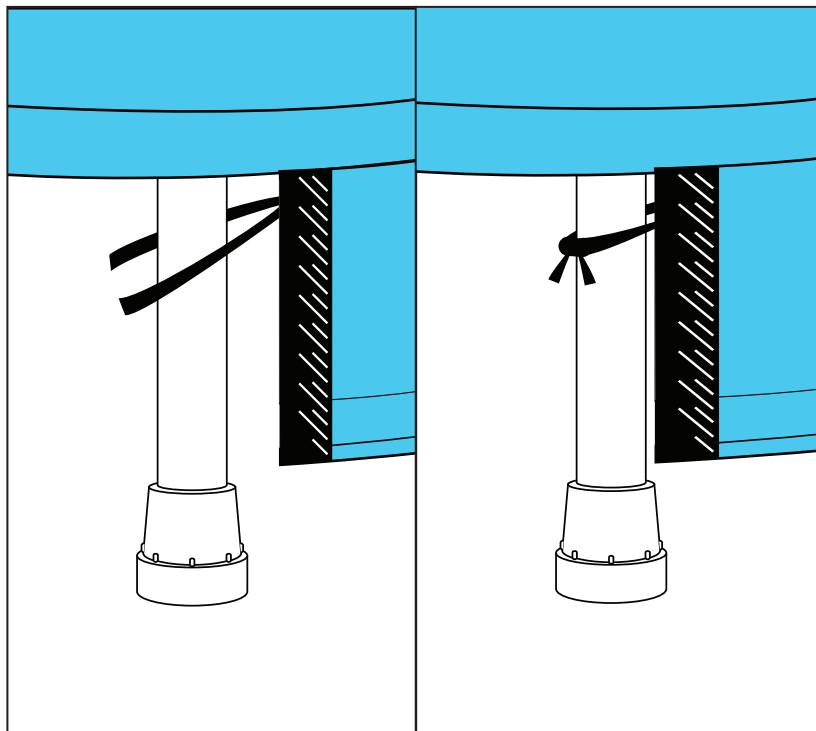

There are 3 String Locations. In the Back of the Frame Pad, Left Hand Rail, and Right Hand Rail.

Tie all Strings to the closest/respective legs to ensure the Frame Pad is snug to the Frame and won't move while in use.

FREQUENTLY ASKED QUESTIONS

- Question: “One of my trampoline legs has broken” or “The trampoline padding or mat is damaged, how do I replace it?”
- Answer: If you are still within your warranty period (90 days from initial purchase) You should contact customer service. You can also purchase select replacement parts at: www.PureFun.net
- Question: “I had a part missing from my box” or “something was damaged during assembly, can you send it to me?”
- Answer: If it has been 30 days or less from the date of your initial purchase, you can contact customer service for a replacement part to be issued.
- Question: “How do I remove the black caps on the frame of the trampoline?”
- Answer: Please refer to page seven of this manual for instructions on how to remove the leg cap covers from the trampoline frame.

CARE & MAINTENANCE

- It is essential that the intended site for this trampoline is completely flat and level. If the ground is not level this will cause movement in the frame and could cause stress on the joined sections.
- Before each use of this product, inspect the entire assembly and replace any worn, defective or missing parts.
- The following conditions could represent potential hazards: Missing, improperly positioned, or insecurely attached frame padding; Punctures, frays, tears, or holes worn in the bed or frame padding; Deterioration in the stitching or fabric of the bed or frame padding; Broken or missing springs; A bent or broken frame; A sagging jump mat; or sharp protrusions on the frame or suspension system; Cease using trampoline immediately and secure it against unauthorized use if any of these conditions are present.
- If any part of the trampoline frame requires cleaning, simply wipe with a damp cloth. (Do not jump on the trampoline after cleaning until completely dry).
- To clean chalk from mat, wipe down net with wet rag. Allow mat to fully dry before jumping.

Thank You Coupon!

As a way of saying thank you for purchasing one of our products, here is a 10% OFF coupon for your next purchase at

www.PureFun.net

Use Code: GQBRANDS10 at Checkout