

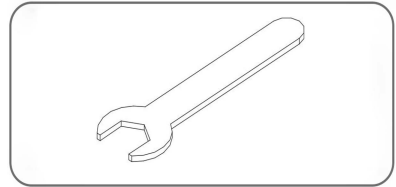





**Please scan the QR code to  
check the assemble video**

**⚠ Attention:** If you notice any fingerprints on the surface please know that they were left there during manual lifting. Simply clean the surface using a cloth and rubbing alcohol.

1. Gather and organize all required parts before assembling.
2. Assemble cabinet on a flat, clean, soft surface.

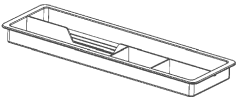
## Tools Required For Assembly

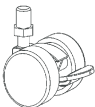

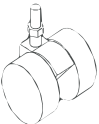
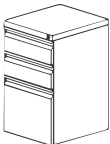
Item no.	Reference Image	Qty.	Item no.	Reference Image	Qty.
<b>a</b>		X1	<b>e</b>		X1
<b>b</b>		X1	<b>f</b>		X1
<b>c</b>		X2	<b>g</b>		X1
<b>d</b>		X2	<b>h</b>		X1

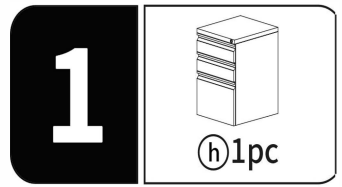

Unlock to open the bottom drawer

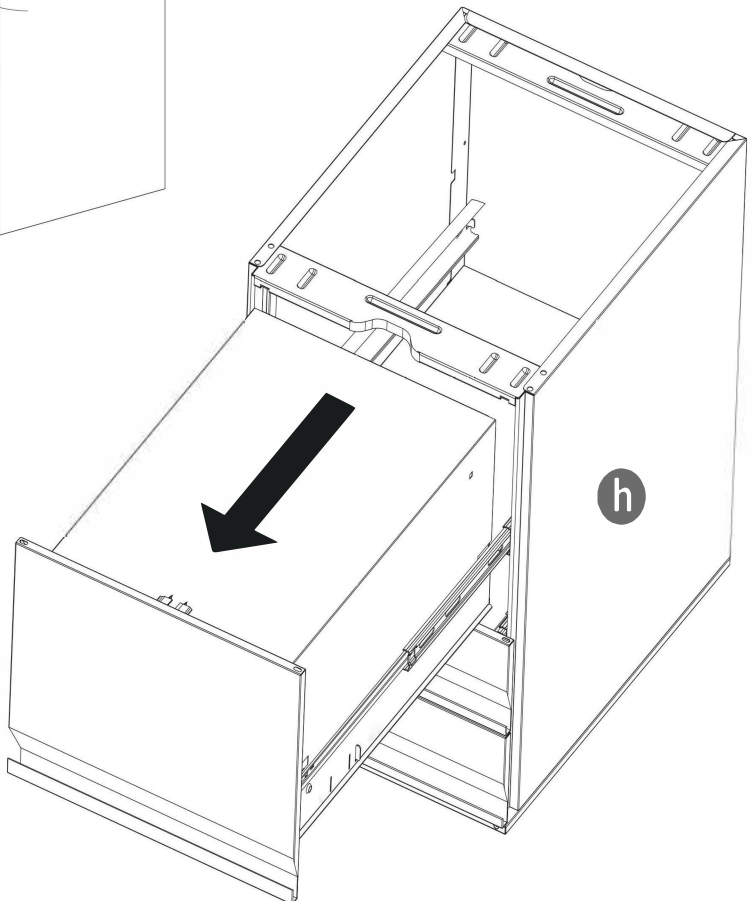
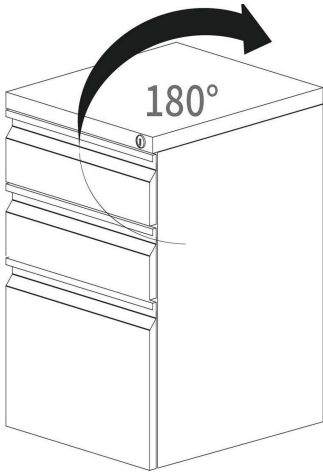

# 2

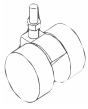

ⓓ 2pcs

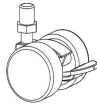

ⓐ 2pcs

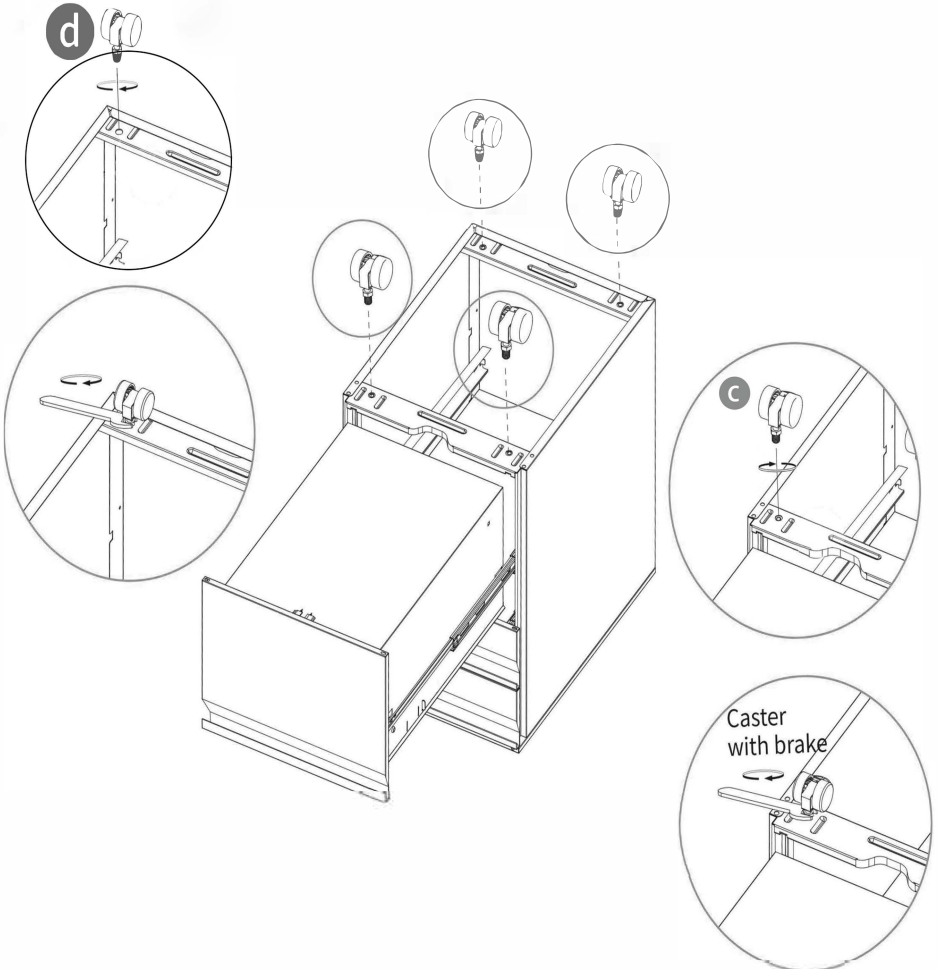

3

ⓑ 1pc

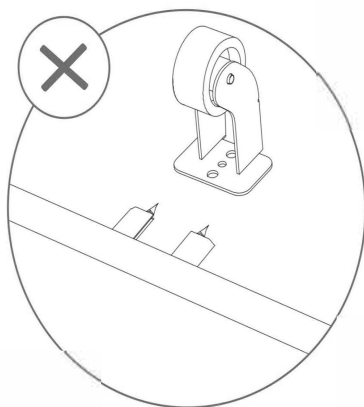
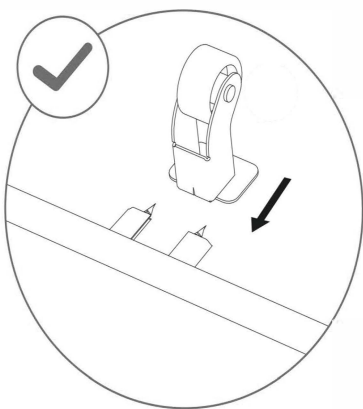
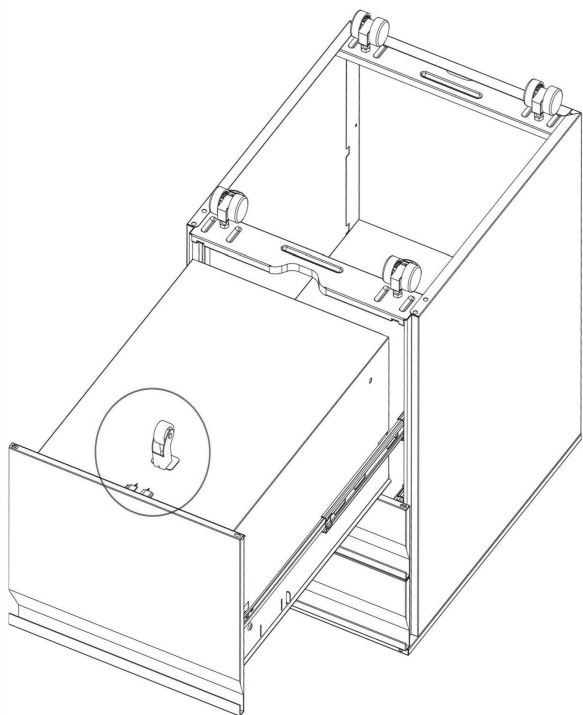
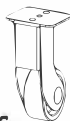

4

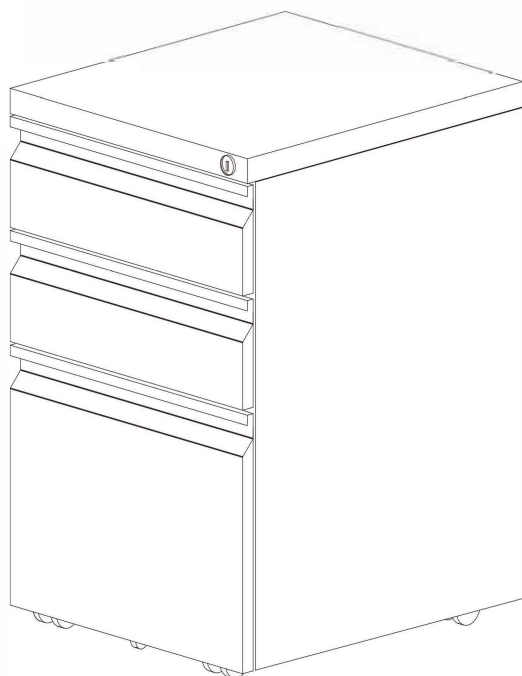
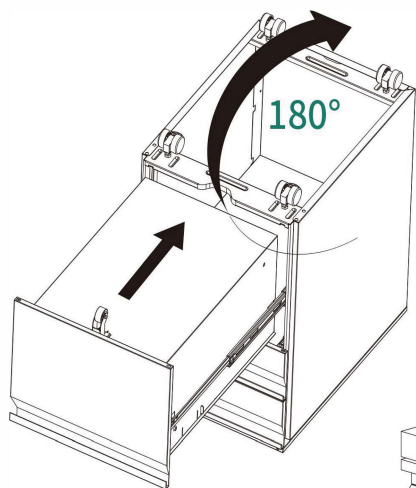

5

# 5



Ⓐ 1pc

Open the bottom drawer, install the rubber buckle, and fix the anti-tip wheel (wheel C) in place.

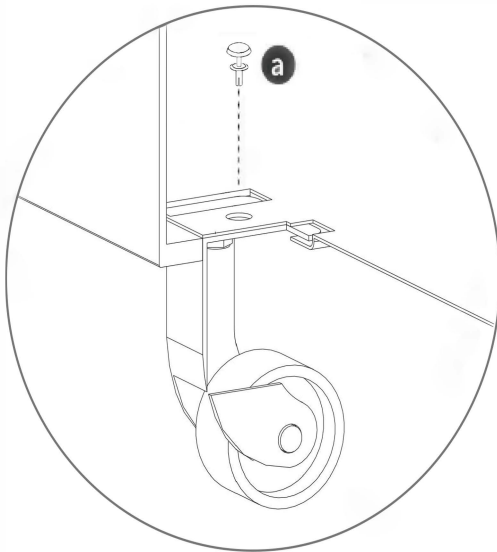
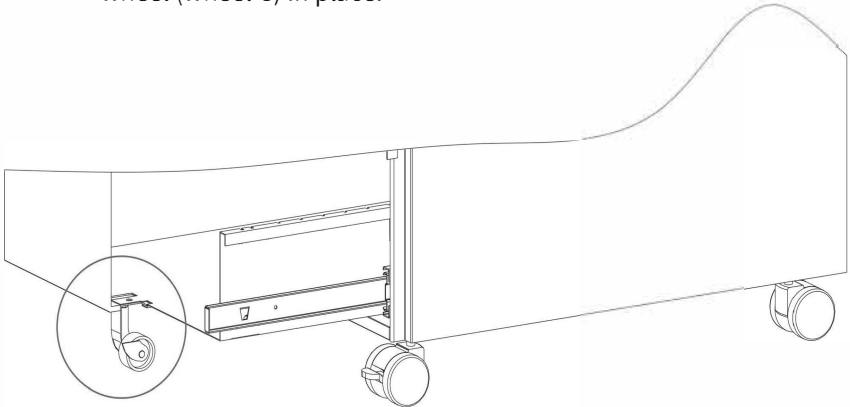

6

6

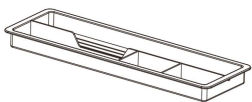

①1pc

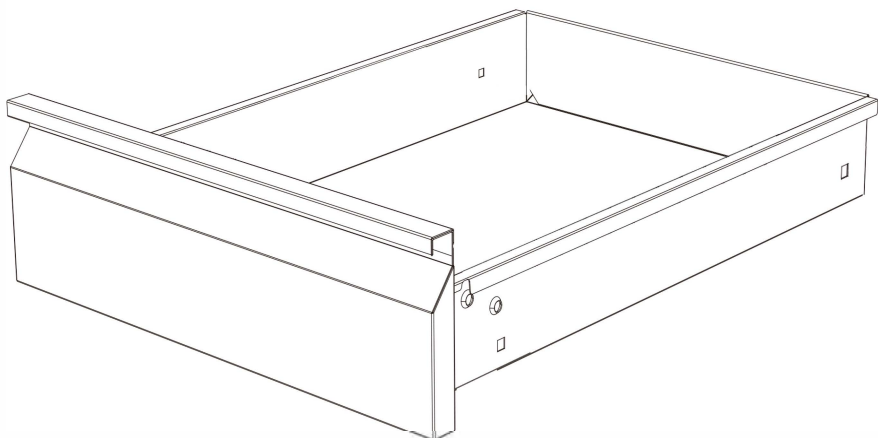
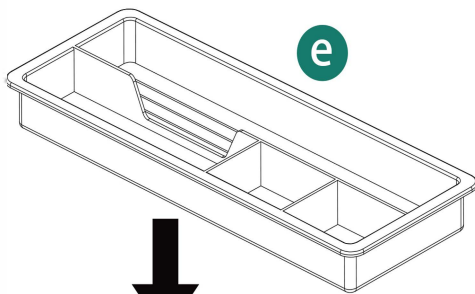

**7**



f 1pc

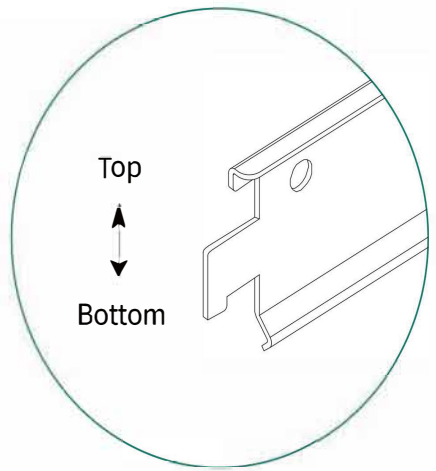
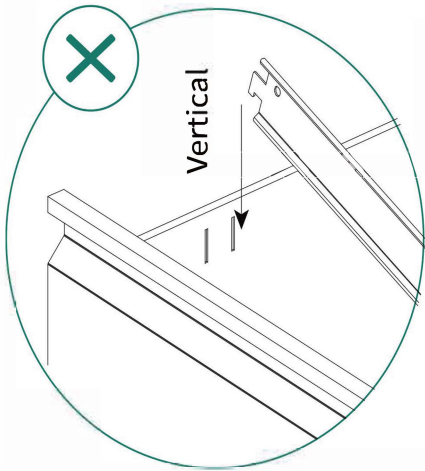
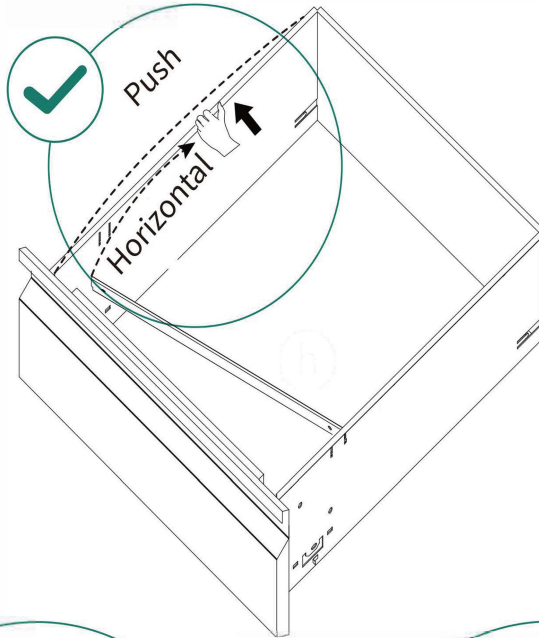

# 8

Lifting the hanging file bar slightly prior to removal makes removing or replacement easier.

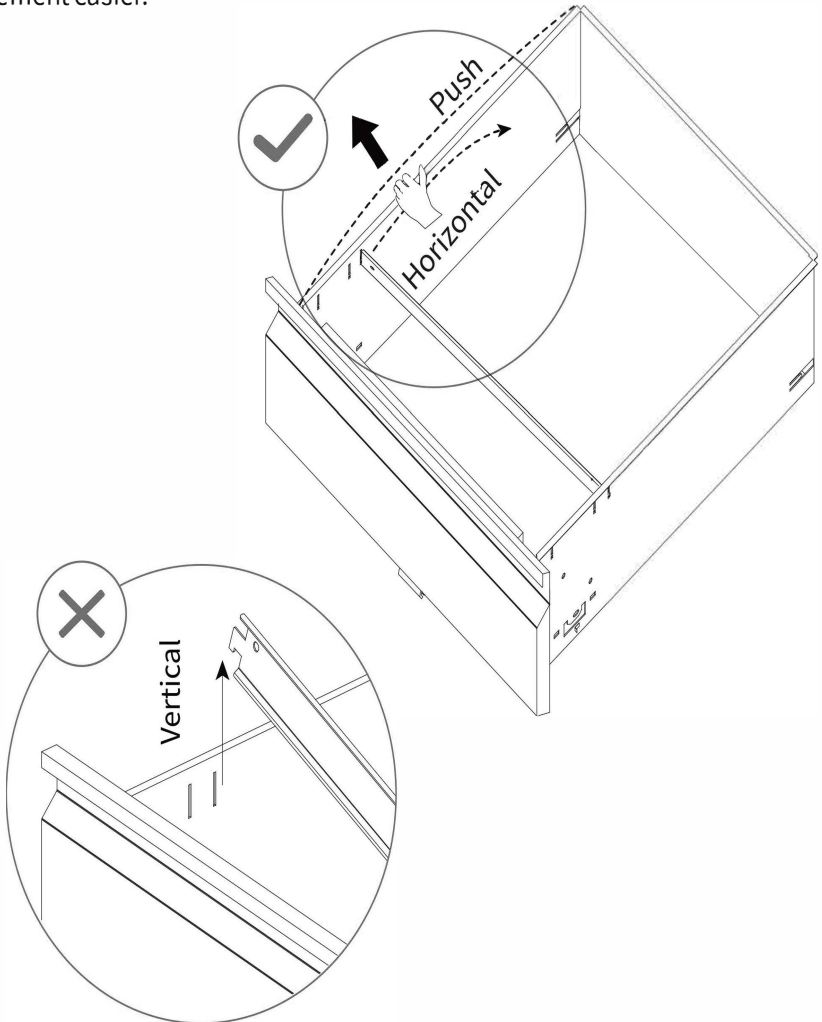

**Instruction: 3 options available (Letter size, Legal size, A4 size)**

Hanging file bar position 1-for Letter size file folders.

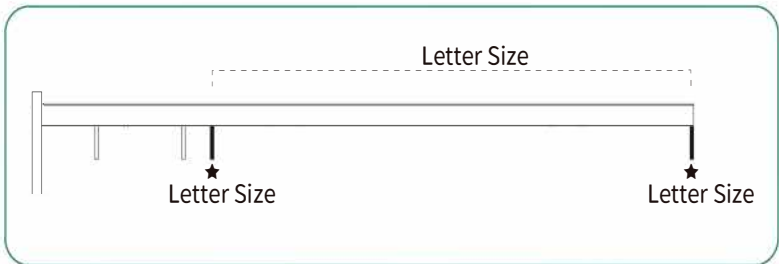
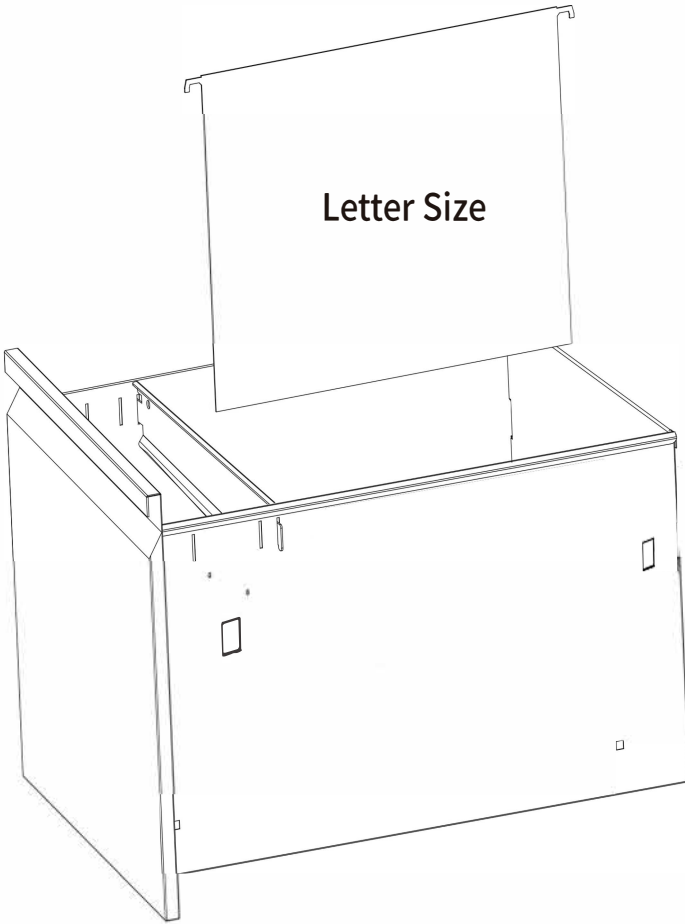

Hanging file bar position 2 – for A4 size file folders.

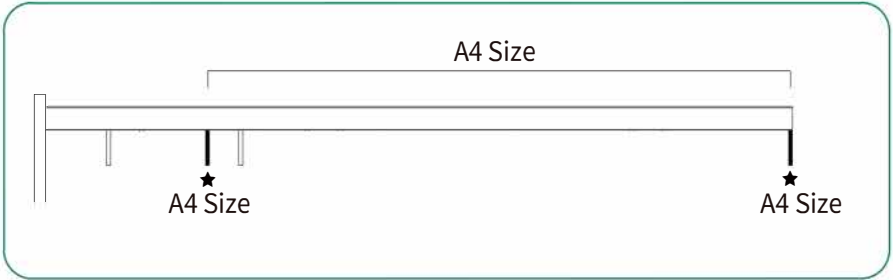
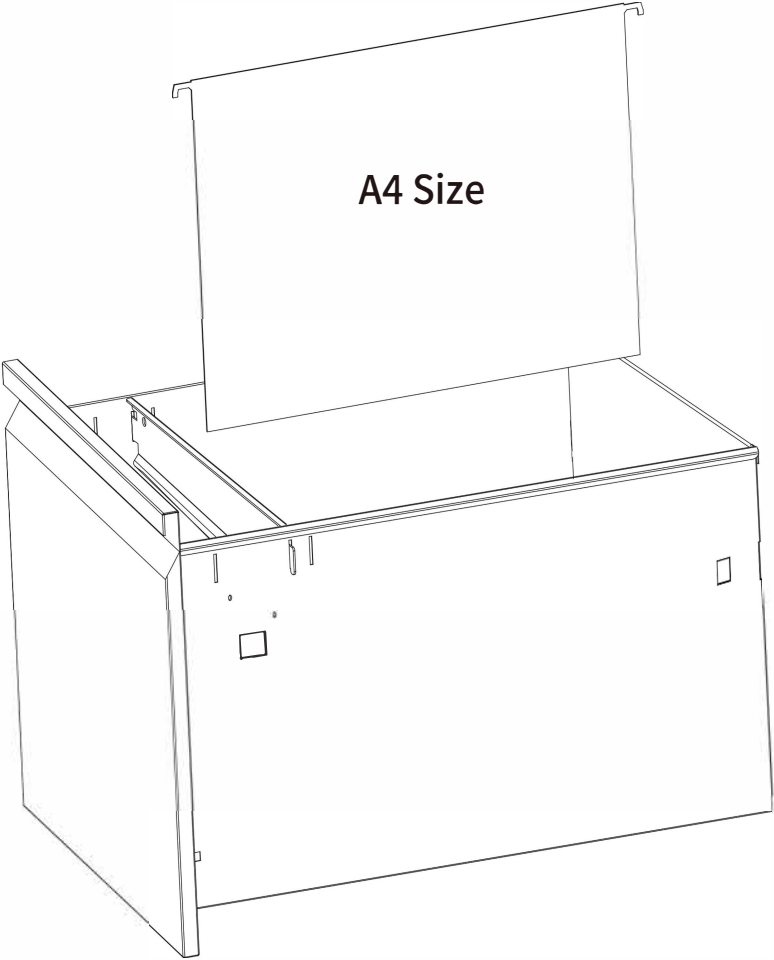

Hanging file bar position 3 – for Legal size file folders.

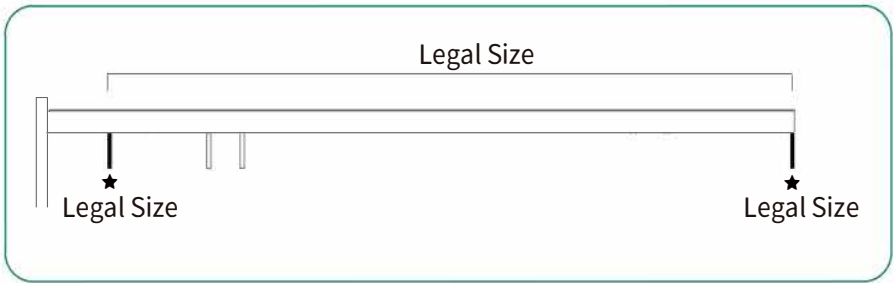
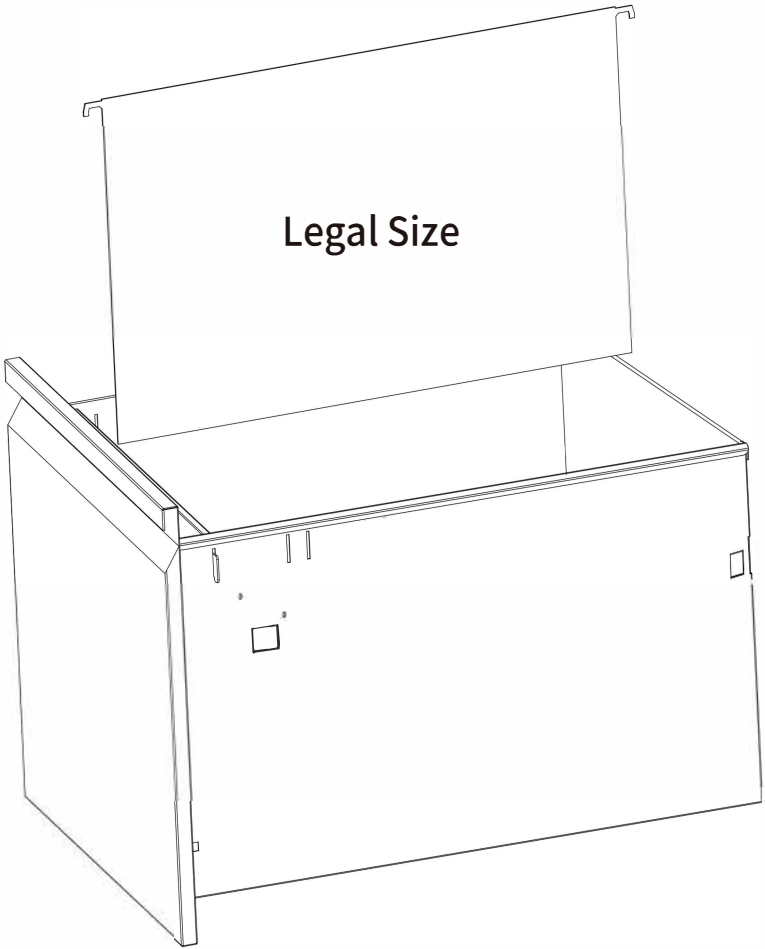

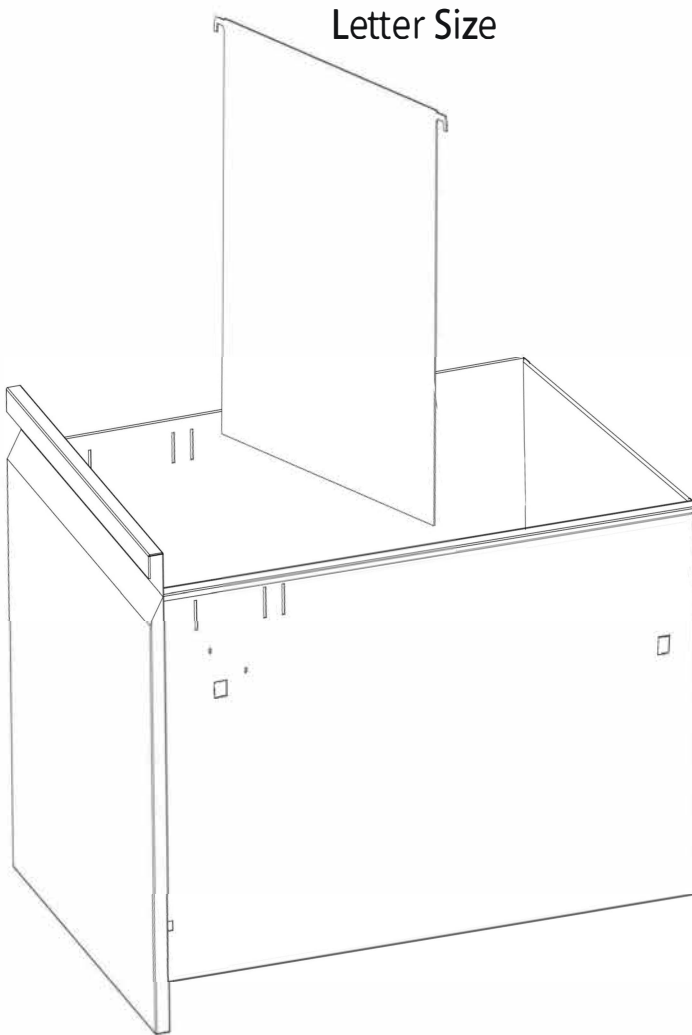

Does not include/ Udeh angning file bar-for Letter size file folders.

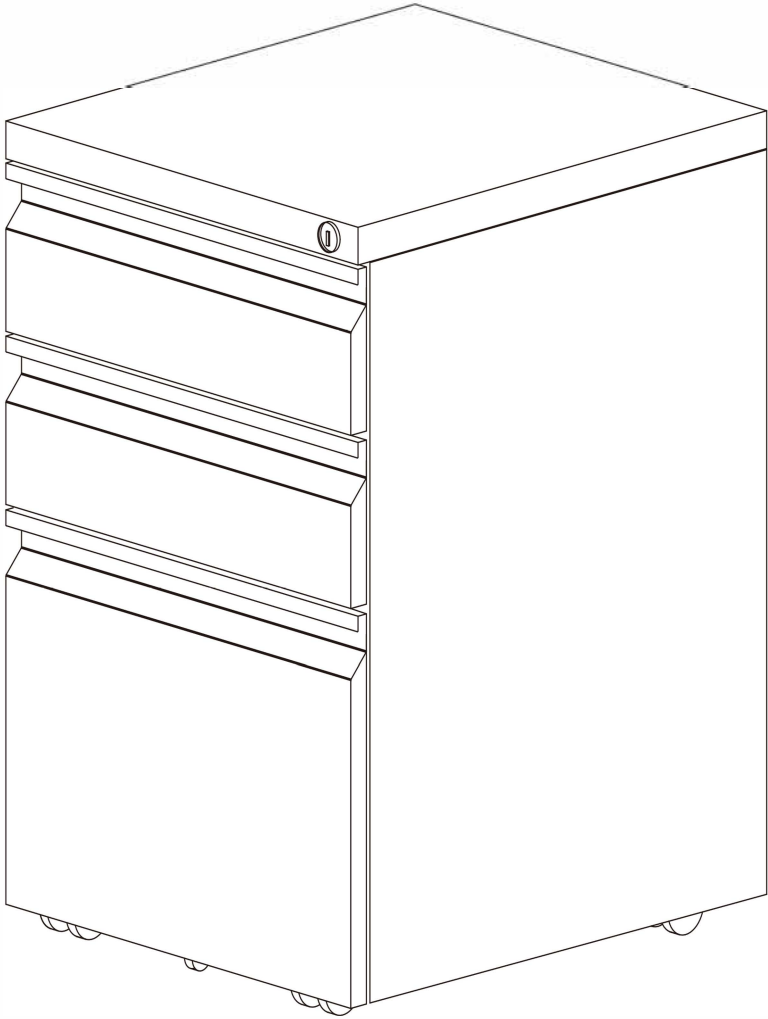

**Installation Completed**

