

16911-N



Call Us First!
DO NOT RETURN TO STORE.

For immediate help with assembly or product information

call our toll free number:

1-800-577-9663

or email:

customerservice@heartlandind.com

Our staff is ready to provide assistance

March through November

M-F 8:00 AM to 9:00 PM EST / 6:00 PM PST

Saturday 8:30 AM to 5:00 PM EST / 2:00 PM PST

December through February

M - F 8:00 AM to 8:00 PM EST / 5:00 PM PST

Saturday 8:30 AM to 5:00 PM EST / 2:00 PM PST

(This page intentionally left blank.)



PREMIUM PLAY SYSTEMS
A Backyard Products Company

ASSEMBLY MANUAL

16911-N

06-19-2020

ROCKPORT 8' x 12' (244 x 366 cm)

ACTUAL FLOOR SIZE IS 96 x 141" (243,2 x 358,1 cm)

KEEP THIS MANUAL FOR FUTURE REFERENCE

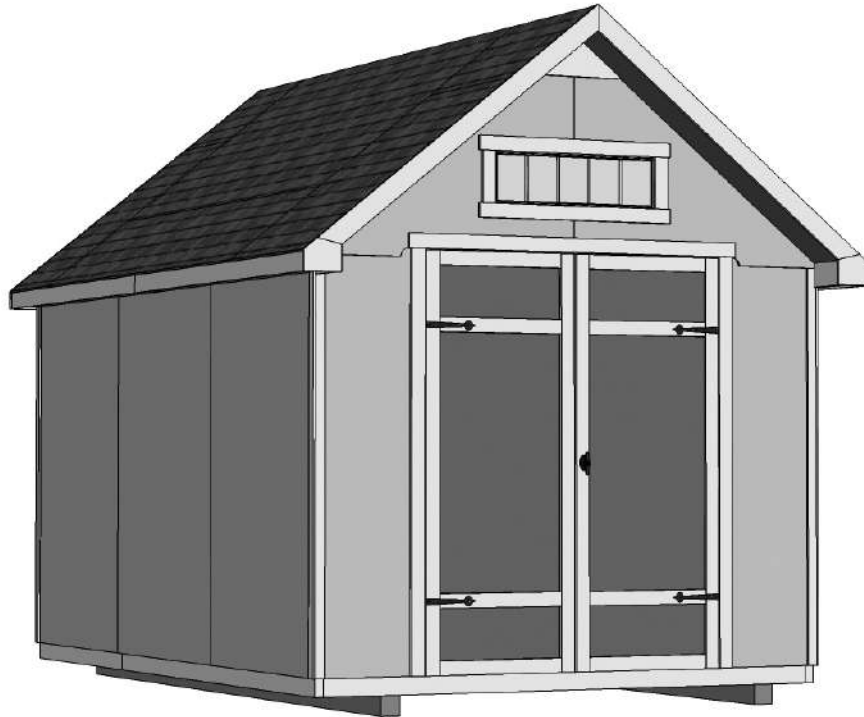

! IMPORTANT! !

READ INSTRUCTIONS THOROUGHLY PRIOR TO BEGINNING ASSEMBLY.

BEFORE YOU BEGIN

- **BUILDING RESTRICTIONS AND APPROVALS**

Be sure to check local building department and homeowners association for specific restrictions and/ or requirements before building.

- **ENGINEERED DRAWINGS**

Contact our Customer Service Team if engineered drawings are needed to pull local permits.

- **SURFACE PREPARATION**

To ensure proper assembly you must build your shed on a level surface. Recommended methods and materials to level your shed are listed on page 7.

- **CHECK ALL PARTS**

Inventory all parts listed on pages 4-6.

- **ADDITIONAL MATERIALS**

You will need additional materials to complete your shed. See page 3 for required and optional materials and quantities.











*****CONTACT OUR CUSTOMER SERVICE TEAM
IF ANY PARTS ARE MISSING OR DAMAGED*****



Call: 1-800-577-9663 email: customerservice@heartlandind.com



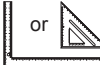

TOOLS

Required

- Phillips Screwdriver 
- Drill / Driver 
 - 1/8" Drill Bit
 - 1/4" Drill Bit
 - 5/16" Drill Bit
 - 1/2" Drill Bit
 - #2 Phillips Drive Bit
- Hammer 
- Level 
- Pencil 
- Tape Measure 
- Square  or 

- Utility Knife 
 - Shingle Blades 
- Caulk Gun 
- Paint Tools 
- Safety Glasses 
- Ladder 

Optional

- Tool Belt/ Nail Pouch 
- Tin Snips (for drip edge) 
- Chalk Line 
- Nail Gun 
 - gun nails
- Gloves 

Safety! Always use approved safety glasses during assembly.

HELPFUL REMINDER SYMBOLS

Look for these symbols for helpful reminders throughout this manual.



= Assistance Required; two or more people.



= Ensure squareness.



= Important required step or operation.



= Helpful assembly hint.



= Mark part with pencil.



BEGIN = Beginning of steps for assembly or installation.



FINISH = You have finished the assembly or installation.



= Level

ORIENT LUMBER AND TRIM FOR BEST APPEARANCE

Framing lumber is graded for structural strength and not appearance. Exterior trim is graded for one good side.

Always install the material leaving the best edge and best surface visible. Please remember that these blemishes in no way negatively affect the strength or integrity of our product. (See Fig. A, B, C.)

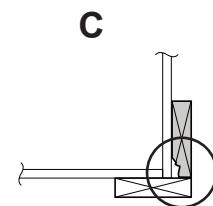
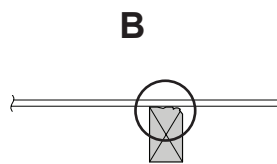
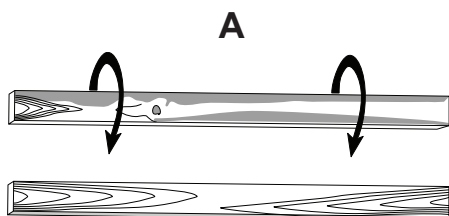

ADDITIONAL MATERIALS

FOUNDATION OR FLOOR MATERIALS

- This shed **does not** include any floor or leveling materials.
- See the FLOOR LEVELING section on page 7 for recommended methods and suggested materials to properly level your floor, as this will vary depending on your specific site.

WOOD FLOOR FRAME

MATERIAL REQUIRED:  Use only wood treated for ground contact and fasteners approved for use with treated wood.

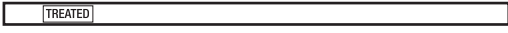
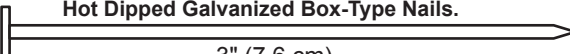
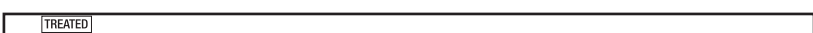
- | | |
|---|---|
| <input type="checkbox"/> x10 
2 x 4 x 93" (5,1 x 10,2 x 236,2 cm) | <input type="checkbox"/> x40 
3" (7,6 cm) |
| <input type="checkbox"/> x2 
2 x 4 x 141" (5,1 x 10,2 x 358,1 cm) | |

FLOOR PANELS

NOTE: Use a minimum of 5/8" (1,6 cm) Oriented Strand Board (OSB)

- | | |
|--|---|
| <input type="checkbox"/> x3 
5/8" x 48" x 96"
(1,6 x 121,9 x 243,8 cm)
•Cut 1 panel to: 45" x 96" | <input type="checkbox"/> x1 
2" (5,1 cm)
1 lb. of 2" (5,1 cm) Hot Dipped Galvanized Box-Type Nails. |
|--|---|

REINFORCED WOOD FLOOR FRAME (OPTIONAL)

IMPORTANT! This floor has been designed for general use. Depending on your specific use you may want to construct a heavy duty floor frame by adding additional floor joists (shown below as shaded). Below is a list of additional materials (not included):

- x2** 2 x 4 x 8' (5 x 10 x 96 cm) Treated Lumber
Cut to 2 x 4 x 93" (5 x 10 x 236,2 cm)
- x8** ea. 3" (7,6 cm) Hot Dipped Galvanized Nails

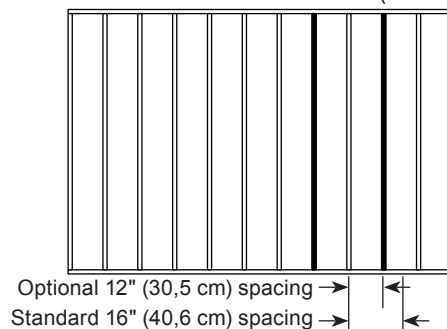

COMPLETING YOUR SHED

You will need these additional materials:

- | | |
|--|--|
| <input type="checkbox"/> 3-TAB SHINGLES 6 Bundles | <input type="checkbox"/> 1" GALVANIZED ROOFING NAILS 3 Lbs
For shingles. |
| <input type="checkbox"/> PAINT FOR SIDING 2 Gallons
Use 100% acrylic latex exterior paint. (2) coats recommended. | <input type="checkbox"/> PAINT FOR TRIM2 Quarts
Use 100% acrylic latex exterior paint. |
| <input type="checkbox"/> CAULK 3 Tubes
Use acrylic latex exterior caulk that is paintable.  | <p>You must caulk completely around window frame to validate your warranty. Use a paintable exterior rated caulk.</p> |

OPTIONAL MATERIALS

- | | |
|---|--|
| <input type="checkbox"/> DRIP EDGE 60 Feet | <input type="checkbox"/> #15 ROOFING FELT
To cover 170 Sq. Ft. of roof area. |
| | <input type="checkbox"/> 1" GALVANIZED ROOFING NAILS1/4 Lb
For roofing felt. |

REFER TO THE BACK OF THIS MANUAL AND THE MANUFACTURER'S INSTRUCTIONS FOR INSTALLATION OF SHINGLES, DRIP EDGE AND FELT.

PARTS IDENTIFICATION AND SIZES

Part identification letters are stamped on some parts.

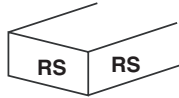

Check these locations for part stamp.

Treated lumber is stamped:

TREATED

WOOD SIZE CONVERSION CHART

Nominal Board Size	Actual Size
2 x 4.....	1-1/2" x 3-1/2" (3,8 x 8,9 cm)
1 x 4.....	3/4" x 3-1/2" (1,9 x 8,9 cm)
2 x 3.....	1-1/2" x 2-1/2" (3,8 x 6,3 cm)
1 x 3.....	3/4" x 2-1/2" (3,8 x 6,3 cm)

PARTS LIST



INVENTORY YOUR PARTS before you begin.

We suggest sorting parts by the category they are listed in.

WALLS

- x1 **GAA** 1 x 3 x 5" (2,5 x 7,6 x 12,7 cm) Gauge Block for 3/4" (1,9 cm) measurement
- x1 **UY** 2 x 4 x 6-1/2" (5,1 x 10,2 x 16,5 cm)
- x2 **RD** 2 x 4 x 16-1/2" (5,1 x 10,2 x 41,9 cm)
- x1 **RH** 2 x 4 x 21-3/4" (5,1 x 10,2 x 55,2 cm)
- x1 **RLB** 2 x 4 x 35-3/16" (5,1 x 10,2 x 89,4 cm)
- x6 **OP** 2 x 4 x 46-1/2" (5,1 x 10,2 x 118,1 cm)
- x19 **UM** 2 x 4 x 68" (5,1 x 10,3 x 172,7 cm)
- x1 **OY** 2 x 3 x 72" (5,1 x 7,6 x 182,9 cm)
- x3 **SZ** 2 x 4 x 89" (5,1 x 10,2 x 226,1 cm)
- x4 **UN** 2 x 4 x 94-1/2" (5,1 x 10,2 x 240 cm)

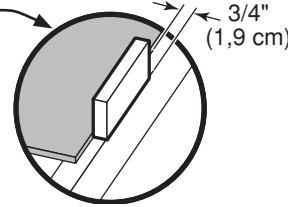









TRIM





- x2 3/8 x 2 x 5" (1,0 x 5,1 x 12,7 cm)
- x2 **EY** 19/32 x 2-1/2 x 9" (1,5 x 6,3 x 22,9 cm)
- x2 **WA** 19/32 x 2-1/2 x 36-3/4" (1,5 x 6,3 x 93,3 cm)
- x2 5/8" x 1-1/2" x 46-3/4" (1,6 x 3,8 x 118,7 cm) OSB
- x1 **WR** 19/32 x 2-1/2 x 63" (2,5 x 6,3 x 160 cm)
- x4 3/8 x 1-3/4 x 67-9/16" (1 x 4,4 x 171,6 cm)
- x4 3/8 x 1-3/4 x 70-1/2" (1 x 4,4 x 179,2 cm)
- x2 3/8 x 3-1/4 x 71-1/4" (1 x 8,3 x 181 cm)
- x2 3/8 x 5-3/16 x 71-1/4" (1 x 13,2 x 181 cm)
- x2 3/8 x 3-1/4 x 79-3/4" (1 x 8,3 x 202,6 cm)
- x2 3/8 x 5-3/16 x 79-3/4" (1 x 13,2 x 202,6 cm)
- x2 5/8" x 1-1/2" x 96" (1,6 x 3,8 x 243,2 cm) OSB

PARTS LIST continued...



OVERHANG & TRIM

- x2**  19/32 x 5-1/2 x 6-13/16" (1,5 x 14 x 17,3 cm) LEFT
- x2**  19/32 x 5-1/2 x 6-13/16" (1,5 x 14 x 17,3 cm) RIGHT
- x6** **URB**  2 x 3 x 5-1/2" (5,1 x 7,6 x 14 cm)
- x2**  3/8 x 4-3/8 x 8-1/2" (1,0 x 11,1 x 21,6 cm)
- x2** **LUA**  2 x 6 x 3-5/8" (5,1 x 15,2 x 9,2 cm)
- x2** **AYB**  2 x 6 x 5-1/4" (5,1 x 15,2 x 13,3 cm)
- x2**  3/8 x 8-1/2 x 61-5/16" (1 x 21,6 x 155,7 cm)
- x4** **PDB**  19/32 x 3-1/2 x 66-1/4" (2,5 x 8,9 x 168,3 cm)
- x4** **SXA**  2 x 3 x 68-7/16" (5,1 x 7,6 x 173,2 cm)

RAFTERS

- x11**  7-1/4 x 18-1/4" (18,4 x 46,4 cm) **OSB OR WOOD GRAIN** 
- x1**  7-1/4 x 18-1/4" (18,4 x 46,4 cm) **WOOD GRAIN**
- x12** **PGA**  2 x 4 x 68-7/16" (5,1 x 10,2 x 173,2 cm)

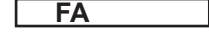
DOOR







- x4** **FA**  19/32 x 2-1/2 x 22-5/8" (2,5 x 6,3 x 57,5 cm)
- x2** **OO**  1-1/4 x 2-1/2 x 69" (3,2 x 6,3 x 175,3 cm)

PANEL PARTS LIST

NOTE: Panel parts are not stamped.

ROOF PANELS

Roof panels are 7/16" (1,1 cm) thick.

- | | |
|--|---|
| <ul style="list-style-type: none"> <input type="checkbox"/> x2  7/16 x 21 x 23-1/4" (1,1 x 53,3 x 59,1 cm) <input type="checkbox"/> x2  7/16 x 21 x 31-3/4" (1,1 x 53,3 x 80,6 cm) <input type="checkbox"/> x2  7/16 x 48 x 23-1/4" (1,1 x 121,9 x 59,1 cm) <input type="checkbox"/> x2  7/16 x 31-3/4 x 48" (1,1 x 80,6 x 121,9 cm) | <ul style="list-style-type: none"> <input type="checkbox"/> x2  7/16 x 21 x 96" (1,1 x 53,3 x 243,2 cm) <input type="checkbox"/> x2  7/16 x 48 x 96" (1,1 x 121,9 x 243,2 cm) |
|--|---|

WALL PANELS & DOORS

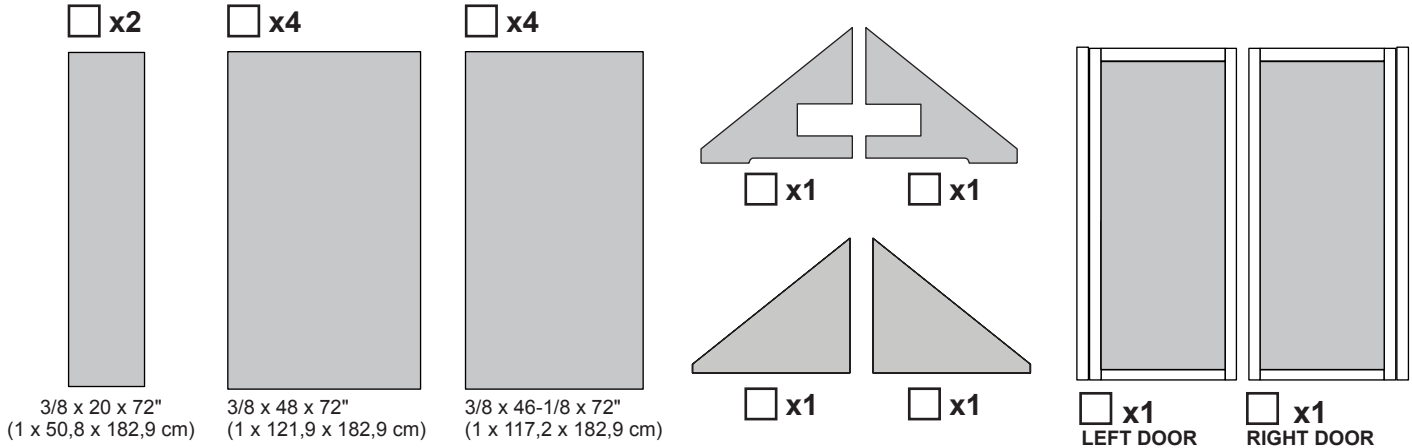

NAIL BOXES

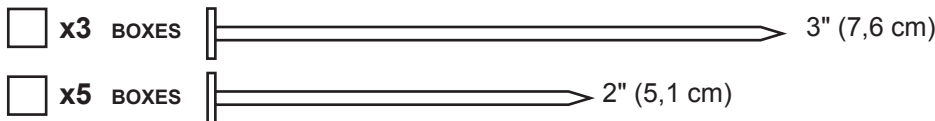

FASTENER/HARDWARE BAG

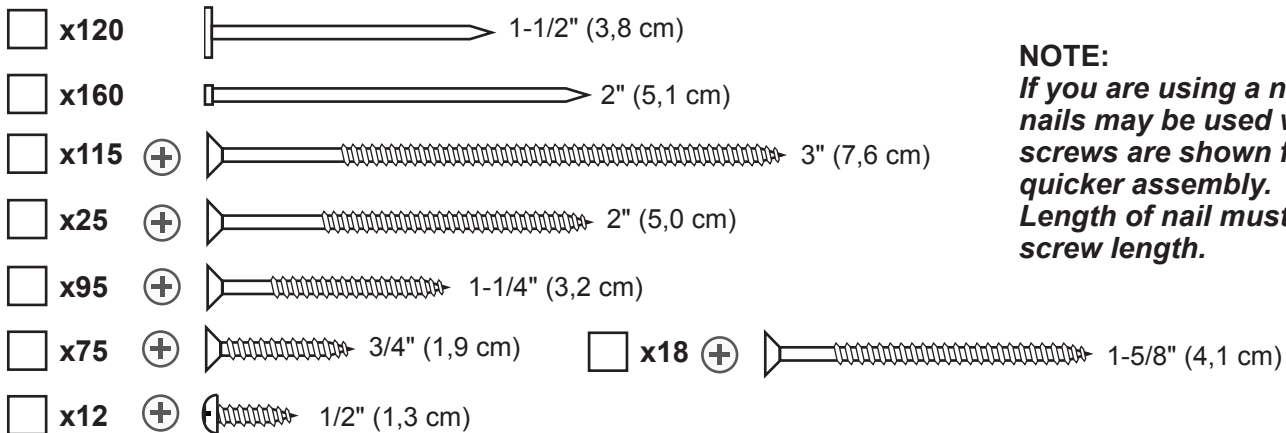

NOTE:
 If you are using a nail gun, nails may be used where screws are shown for quicker assembly. Length of nail must match screw length.

VENT, DOOR HARDWARE, AND WINDOW

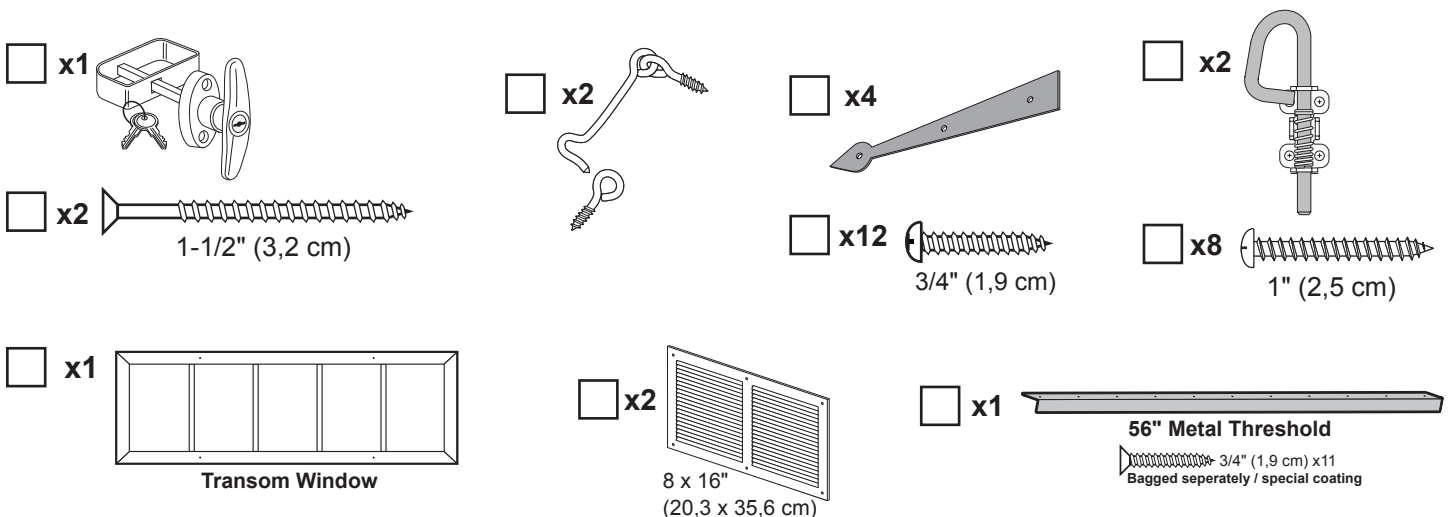

FLOOR LEVELING OPTIONS

There are multiple ways to level your floor frame. Our recommended leveling method is shown below.
Leveling materials are not included in this kit.

PREFERRED METHOD - 4x4 TREATED RUNNERS

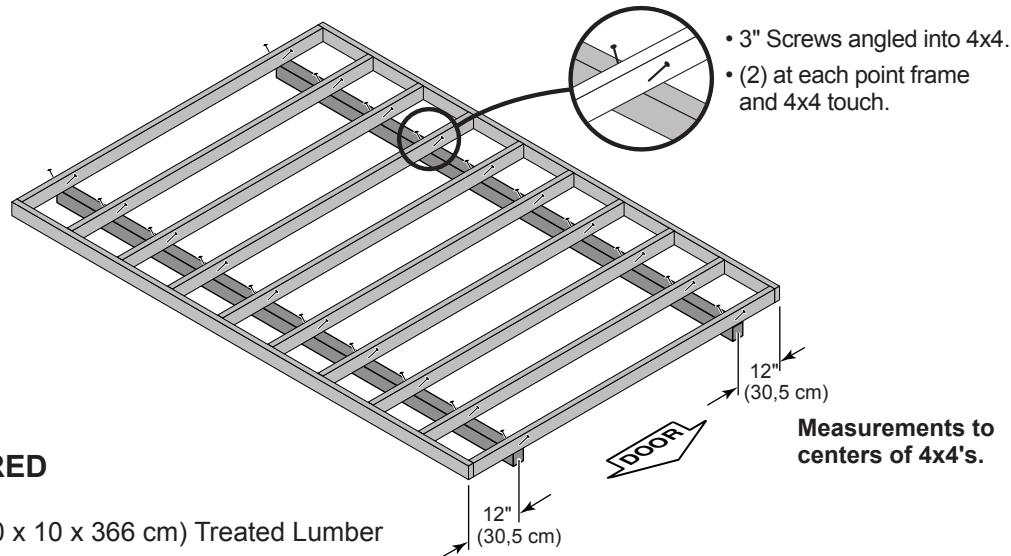

MATERIAL REQUIRED

- x2** 4 x 4 x 12' (10 x 10 x 366 cm) Treated Lumber
- Fasteners for Frame to 4 x 4.**
(3" Screws shown as one option.) Minimum (40) 3" screws / exterior grade.

⚠ Use only wood treated for ground contact and fasteners approved for use with treated wood.

⚠ Always support frame seams.

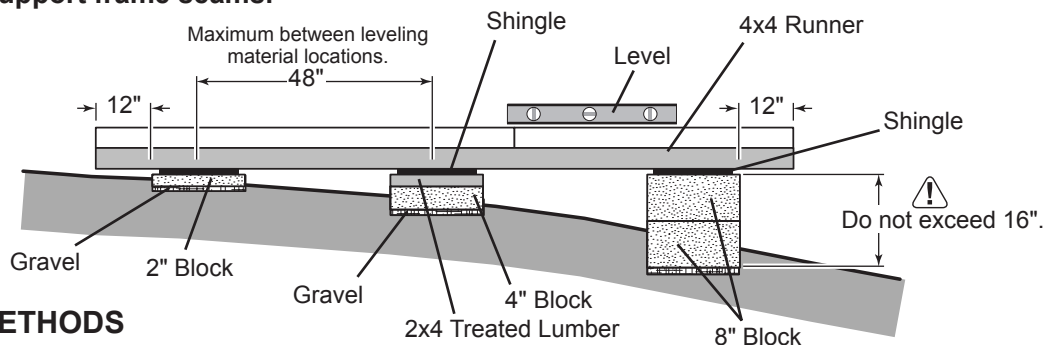

LEVELING METHODS

- Level under 4x4 runners only.
- Locate leveling material 12" from ends of runners and no more than 48" apart.
- Asphalt shingles should be used between 4x4 runners and blocks or treated lumber. Never use shingles in direct contact with ground.
- For best results and aiding in water drainage use gravel under each concrete block.

LEVELING MATERIALS

- Gravel
- Solid Masonry Blocks in 1", 2", 4" or 8" thickness
- 2x4 Treated Lumber
- Asphalt Shingles

⚠ Leveling higher than 16" not recommended.

CONCRETE

- If you are building your shed on a concrete foundation see the following page.

CONCRETE FOUNDATION

Your kit contains all materials to construct a wooden floor. If you choose to install your kit on a concrete slab refer to the diagram below.

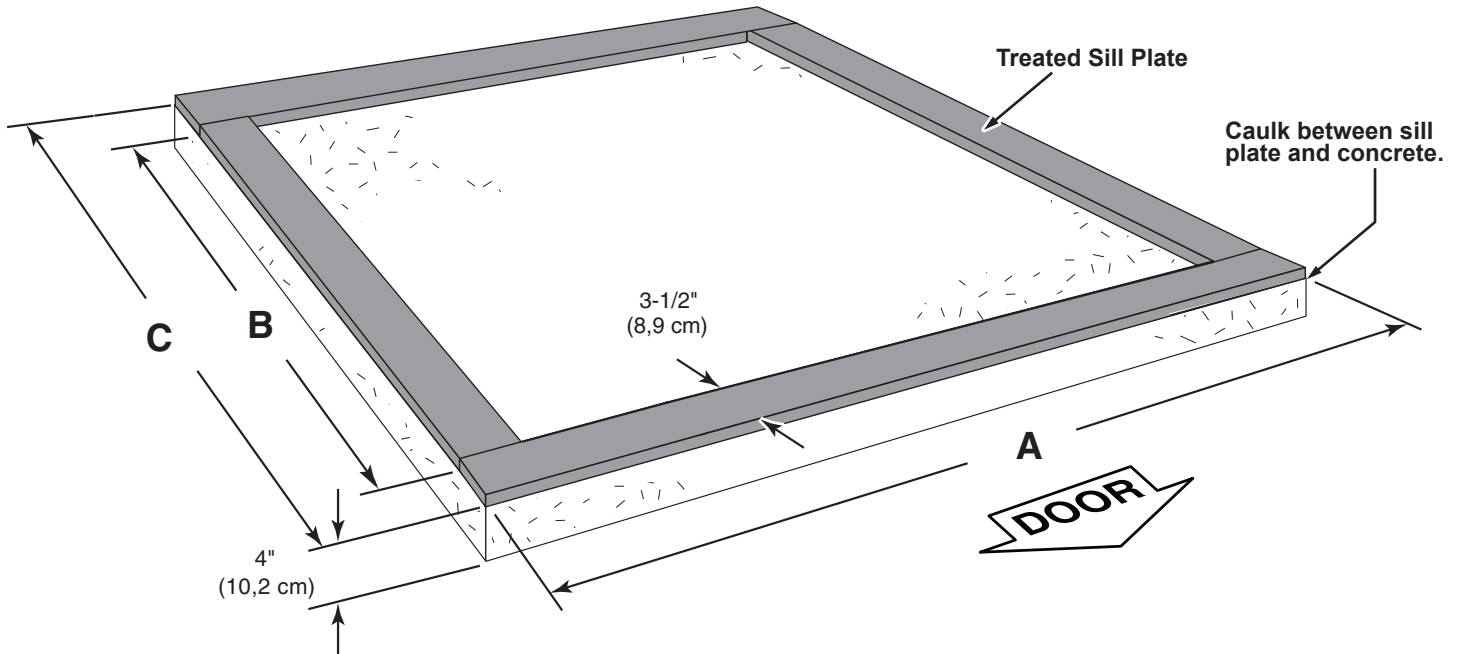

Building Size	Actual Size	A	B	C
8' x 12' (243,2 x 365,8 cm)	96" x 141" (243,2 x 358,1 cm)	96" (243,2 cm)	134" (340,4 cm)	141" (358,1 cm)

Requires:

- x2** 2 x 4 x 11'-2" (5,1 x 10,2 x 344,5 cm) ⚠ **MUST** be treated lumber.
- x2** 2 x 4 x 8' (5,1 x 10,2 x 244 cm) ⚠ **MUST** be treated lumber.
- x1** Caulk

⚠ Allow new concrete slabs to cure for at least seven (7) days.

- A treated 2 x 4 (5,1 x 10,2 cm) sill plate is required when installing your shed on concrete.
Hint: Use treated lumber in your kit or purchase full length treated lumber.
- Use a high quality exterior grade caulk beneath all sill plates.
- Fasten 2 x 4 (5,1 x 10,2 cm) sill plates to slab using approved concrete anchors (**fasteners not included**).
- Check local code for concrete foundation requirements.

NOTES

FLOOR FRAME

PARTS REQUIRED:

x10 TREATED
2 x 4 x 93" (5,1 x 10,2 x 236,2 cm)

Look for
TREATED
Stamp

x40 3" (7,6 cm)

x2 TREATED
2 x 4 x 141" (5,1 x 10,2 x 358,1 cm)



✓ BEGIN

- 1 Orient parts as shown on flat surface. Measure and mark. Use (2) 3" nails at each mark.



HINT:
For easier nailing
stand on frame.

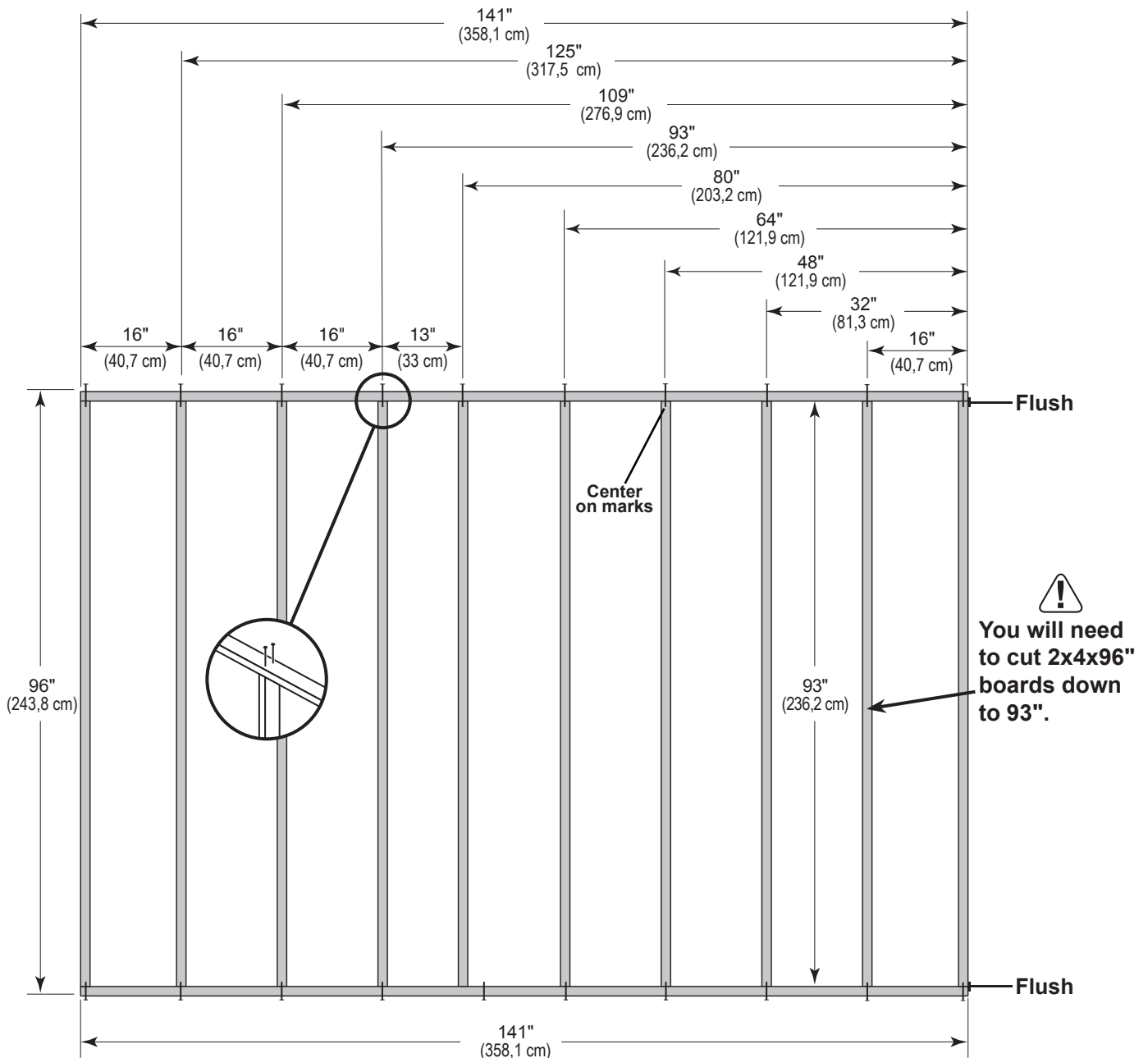
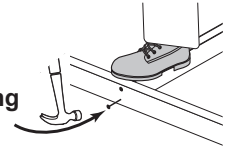

Your floor frame is now assembled.

STOP!



LEVEL AND SQUARE FLOOR FRAME



STOP!

Before attaching floor decking, it is important to level and square the floor frame.
A level and square floor frame is required to correctly construct your shed.

BEGIN

- 1 See page 7 for the preferred floor leveling method.
- 2 Use level and check the frame is level before applying floor panels.
- 3 Check for frame squareness by measuring diagonally across corners. If the measurements are the same, the frame is square. The diagonal measurement will be approximately 170-9/16" (433,2 cm).
- 4 When the frame is level and square, secure one side of frame to the 4x4 runners with one fastener at ends of each runner. Move to the opposite end of the frame. Secure the frame to 4x4 runners with (1) fastener at ends of each runner making sure the frame remains square (**Fig. A**).



FINISH

Once the floor frame is level and square fasten the frame to the 4x4 runners at each point the frame contacts the 4x4 runners.

First, secure
at ends with
(1) fastener.

Fig. A

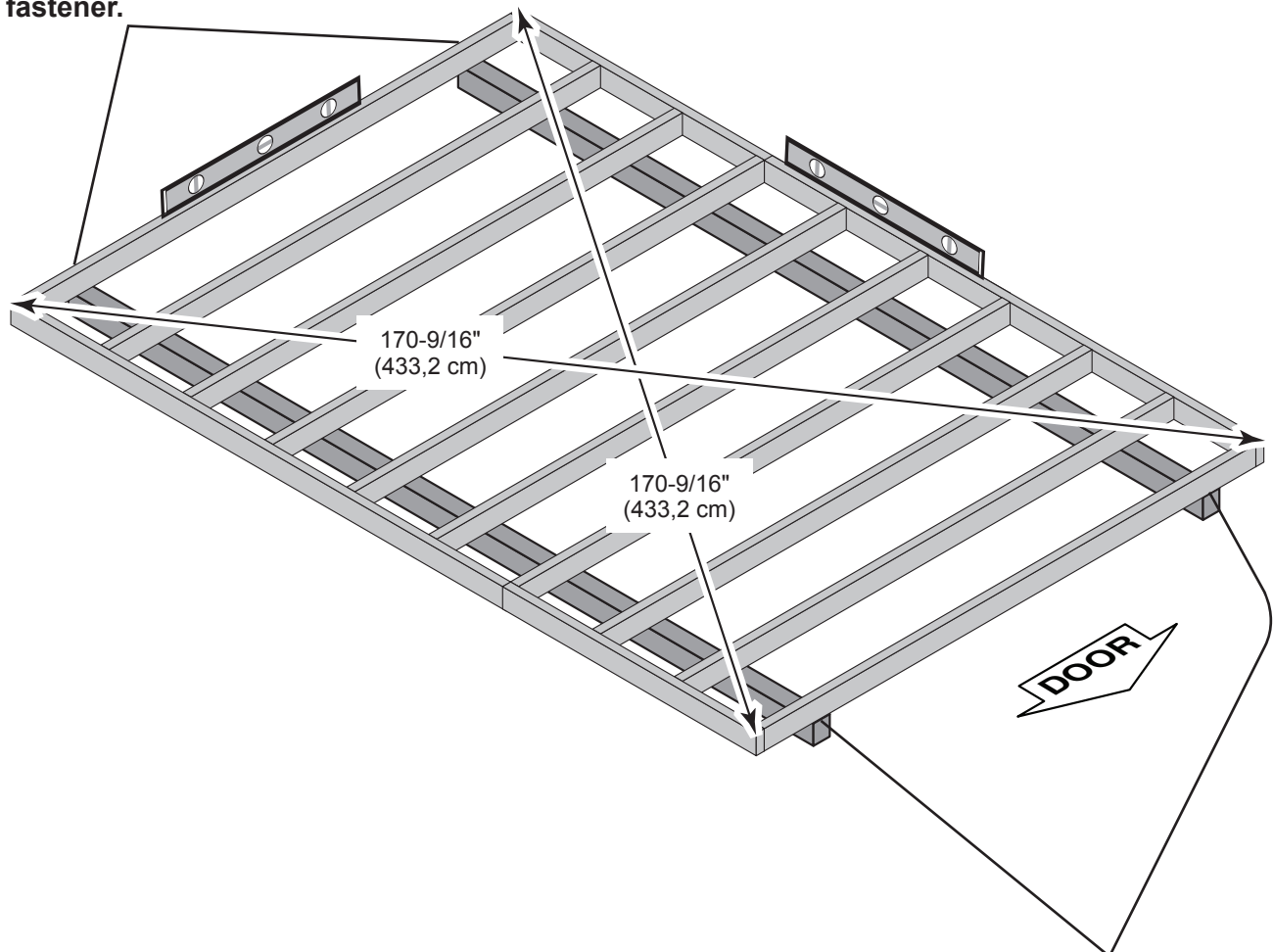

Second, secure
at ends with
(1) fastener.

FLOOR PANELS

PARTS REQUIRED:

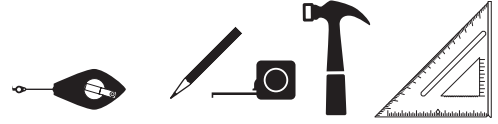
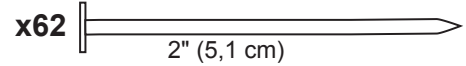
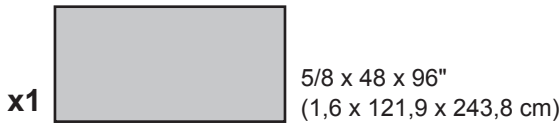

 **Ensure your floor frame is square by installing one panel and squaring frame.**

✓ **BEGIN**

- 1** Attach the **48" x 96"** panel with the rough side up (painted-grid lines side) with the 48" edge and corner flush to the floor frame (**Fig A**). Secure panel with (2) 2" nails in the corners.
- 2** Move to the opposite side. Using the long edge of the panel as a lever, move the panel side-to-side until the top corner is flush to the floor frame (**Fig. B**). Secure panel with (2) 2" nails in the corners.
- 3** Continue attaching the panel with using 2" nails 6" apart on edges and 12" apart inside panel. Use a chalk line or use pre-painted grid lines to nail into joists under panel.

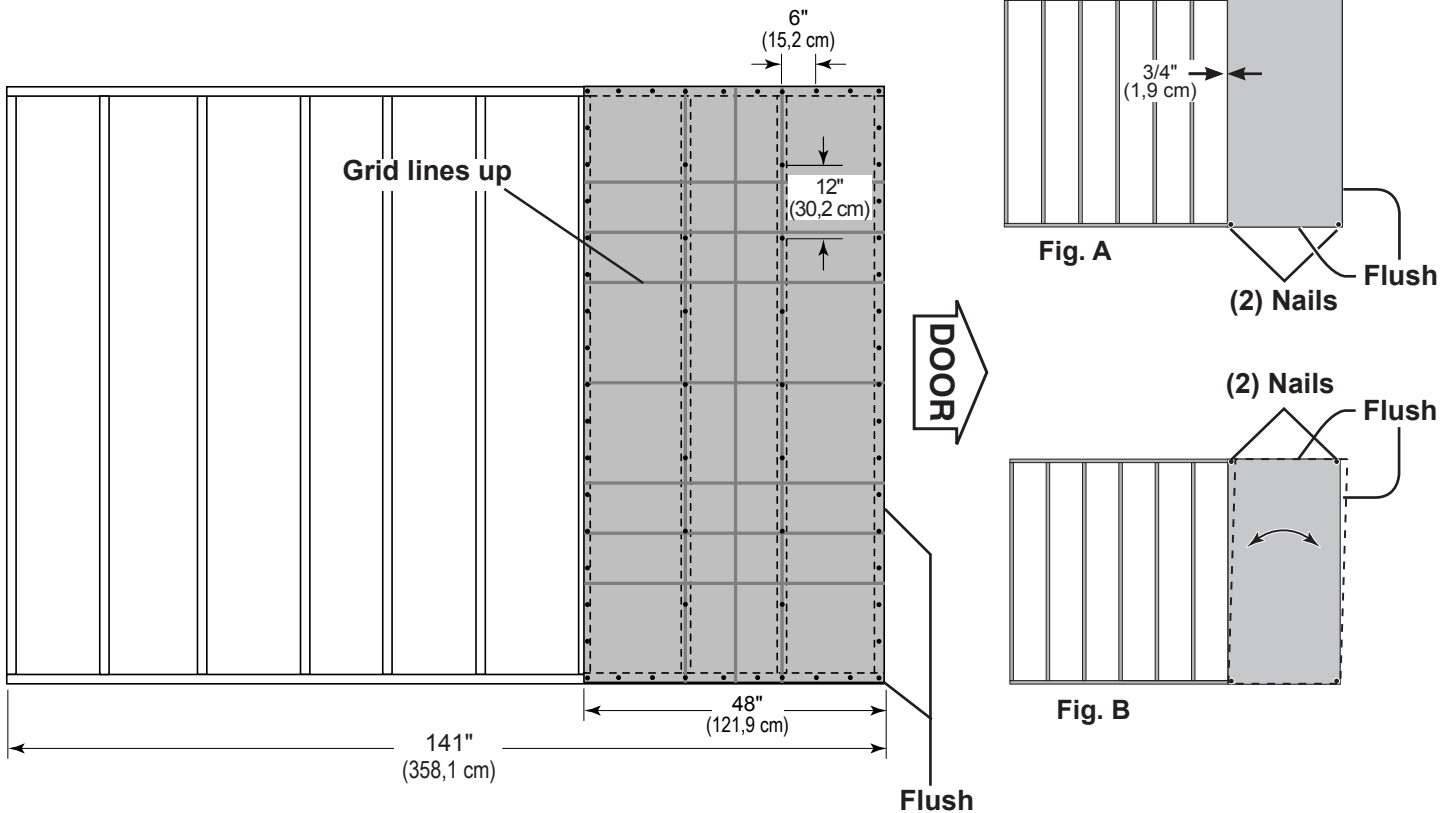

FLOOR PANELS

PARTS REQUIRED:

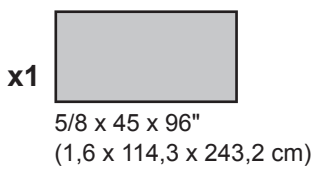
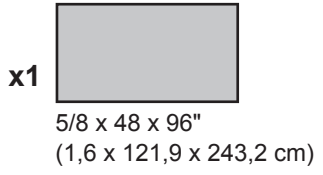
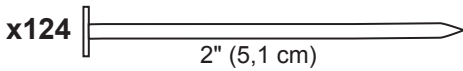

- 4** Continue installing panels with rough side up (painted grid lines).
install **45"** panel in middle of floor frame.

Use grid lines on panels for 2" nails 6" apart on edges and 12" apart inside panels.

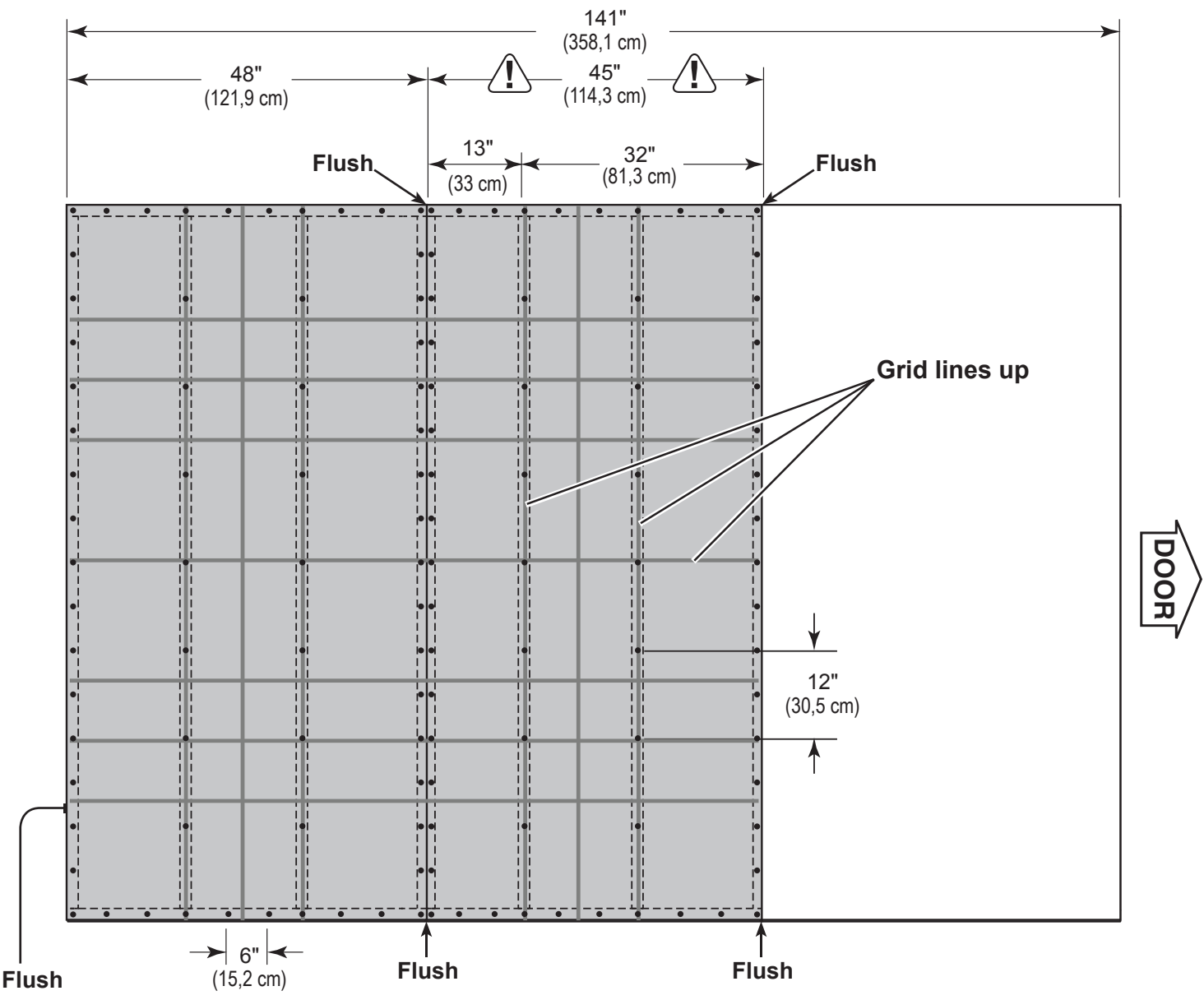

Your floor panels are now installed.

IMPORTANT!

STOP!

Check the floor frame is level after installing floor panels.
Re-level if needed.

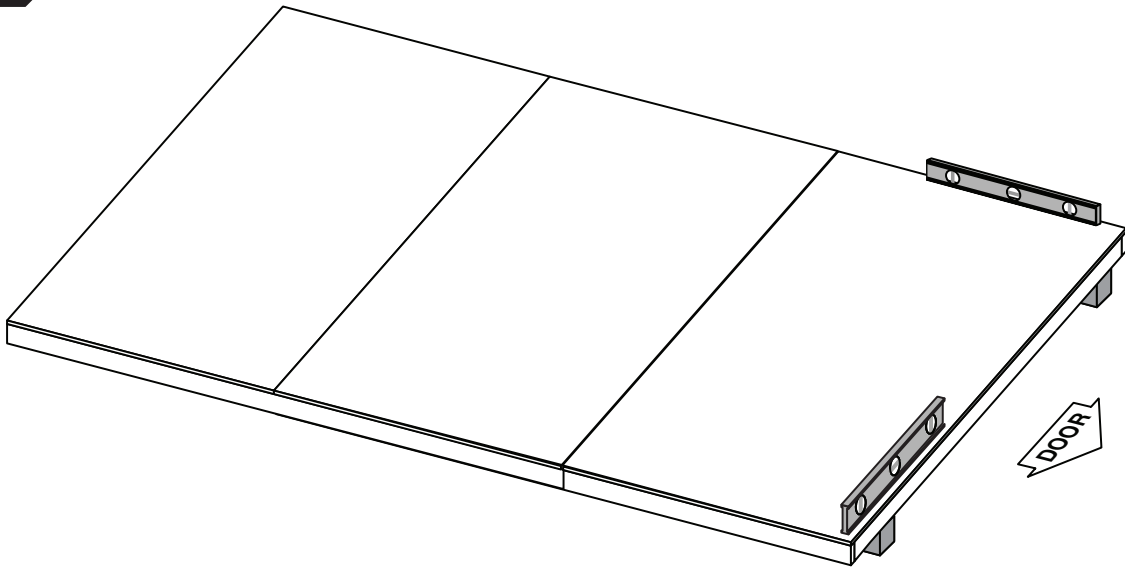

HINT:

- The floor should be used as a stable work surface for wall construction.
- Organize your assembly procedure during the build process to avoid over-handling of the walls.

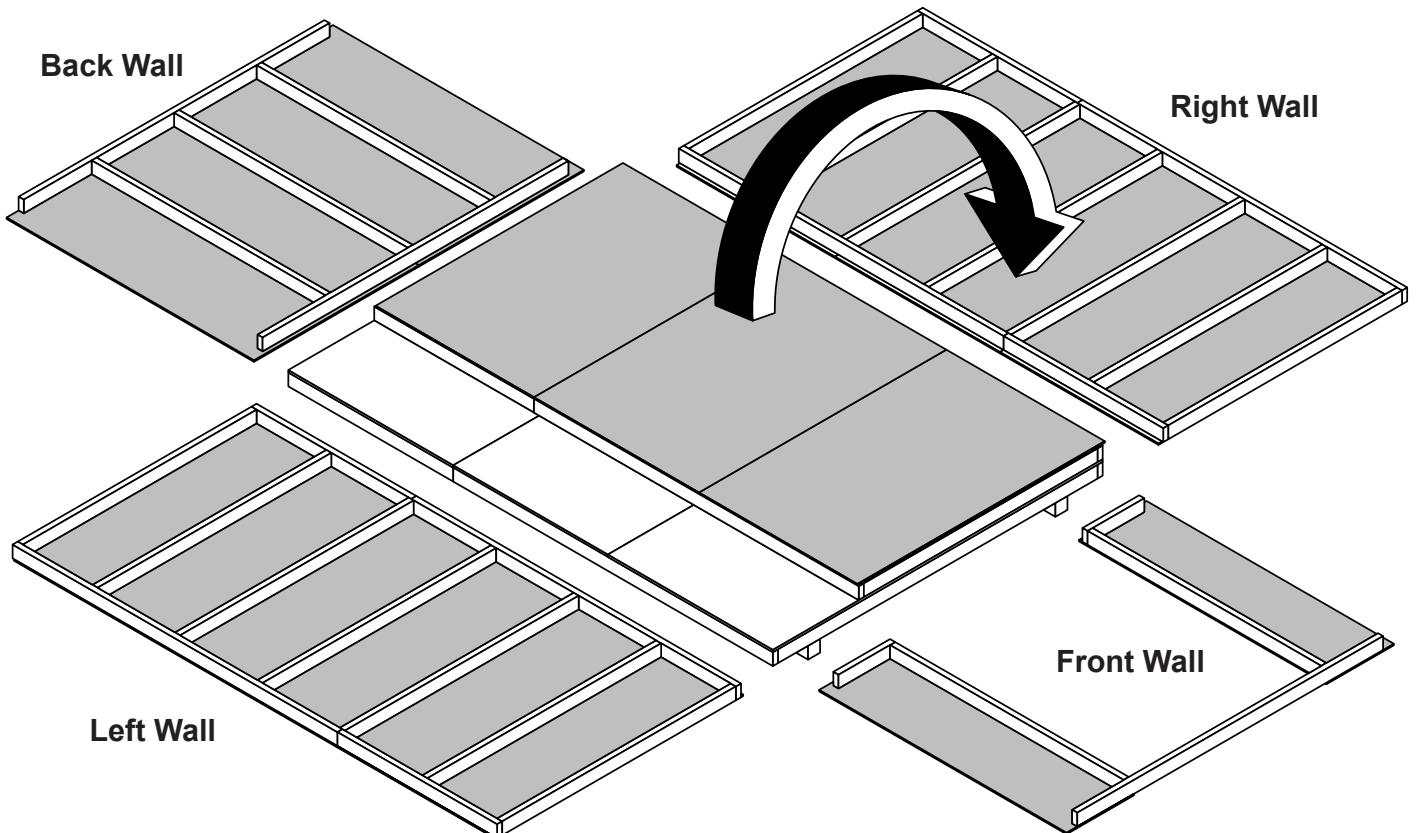

SIDE WALL PANELS

PARTS REQUIRED:



x1
46-1/8 x 72"
(117,2 x 213,4 cm)



3/4" GAUGE
BLOCK

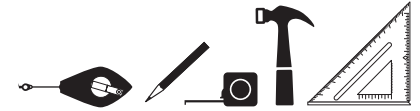
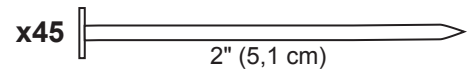

Ensure your wall frame is square by installing one panel and squaring frame.

3

Place 46-1/8" x 72" panel onto wall frame flush to top of frame with primed side up as shown.

Use the gauge block to mark the 3/4" measurement on the wall stud. Secure panel with (2) 2" nails in the corners (**Fig. A**).

4

Move to the opposite end. Using the long edge of the panel as a lever move the panel side-to-side until you have a 3/4" measurement on the wall stud. Secure corner with (2) 2" nails (**Fig. B**).

Nail the panel with 2" nails 6" apart on edges and 12" apart inside panel.

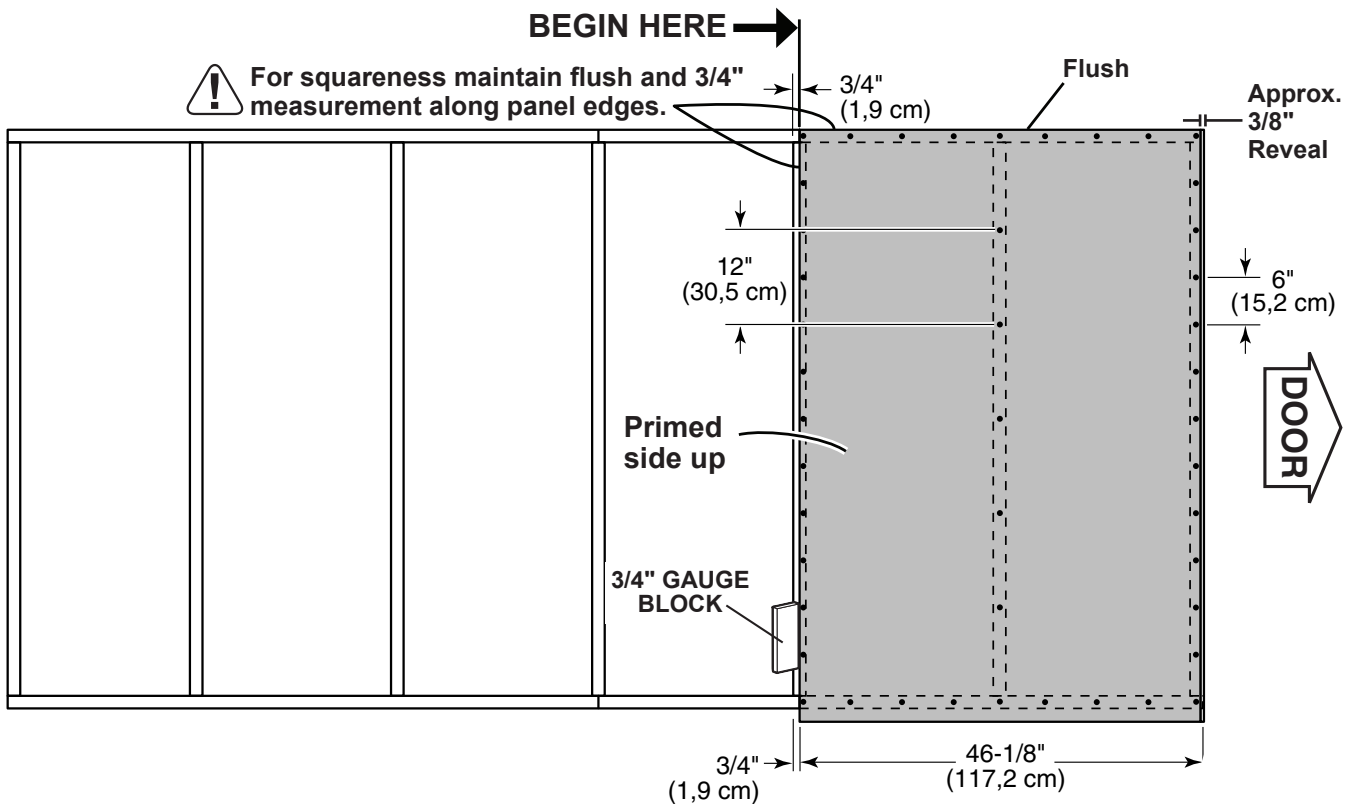
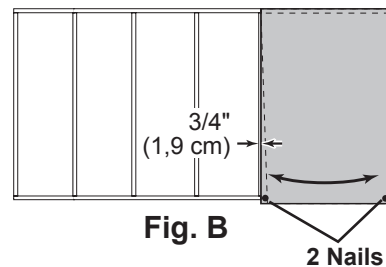
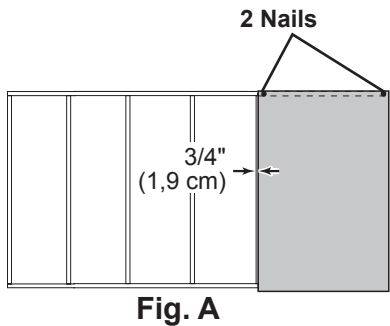

SIDE WALL PANELS

PARTS REQUIRED:

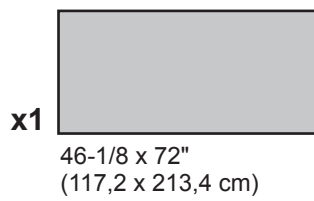
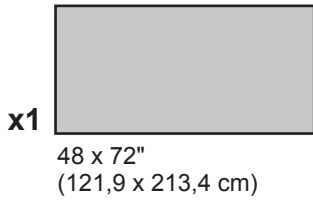

3/4" GAUGE BLOCK

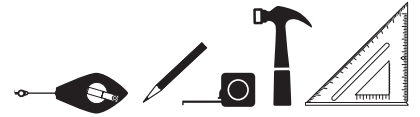
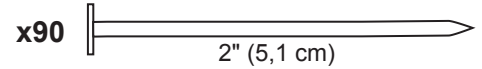

- Place center 48" x 72" panel on frame as shown with primed side facing up. Secure with 2" nails 6" apart on edges and 12" apart inside panel.

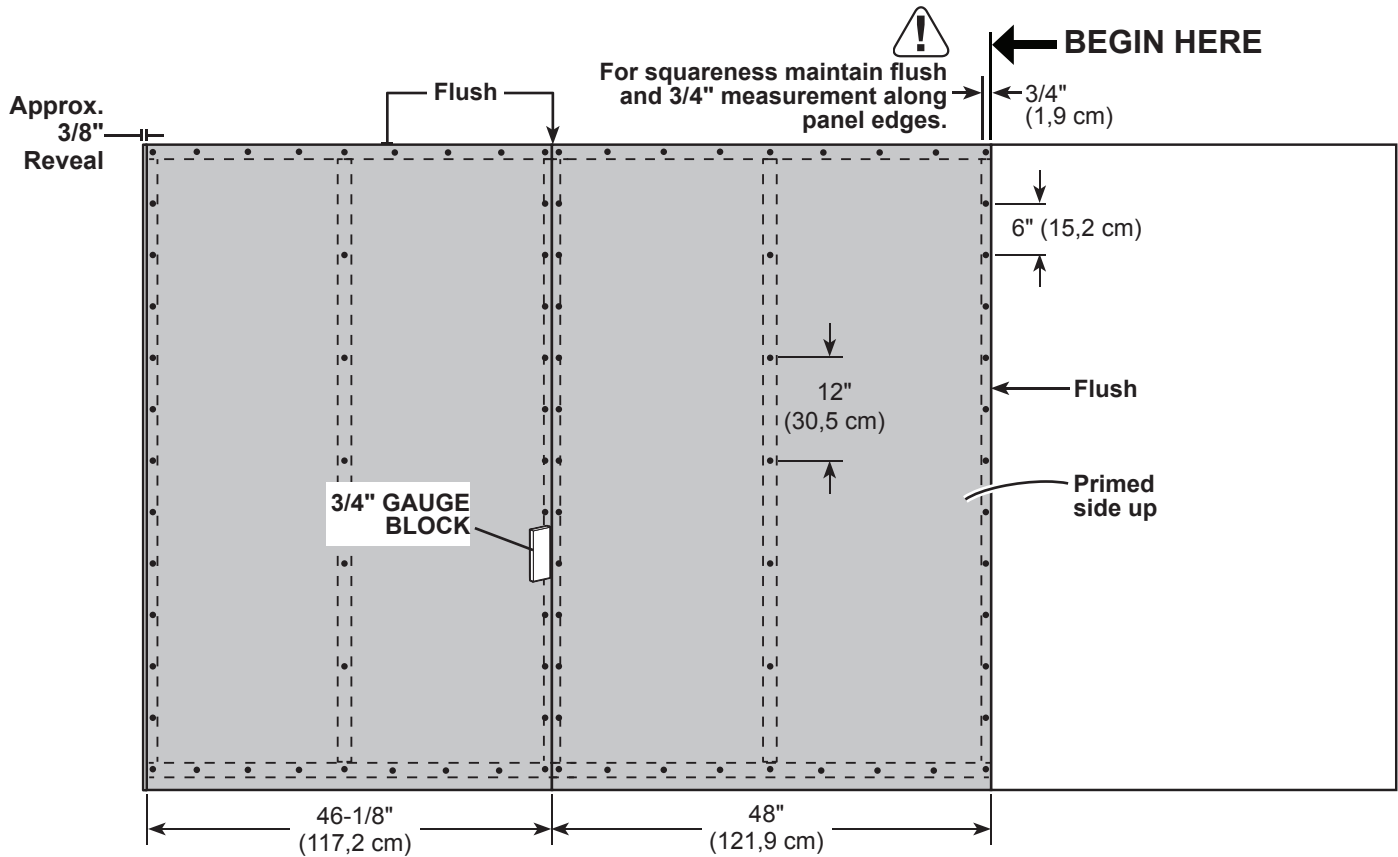

- Place end 46-1/8" x 72" panel on frame as shown with primed side facing up. Secure with 2" nails 6" apart on edges and 12" apart inside panel.

Carefully flip the side wall over.

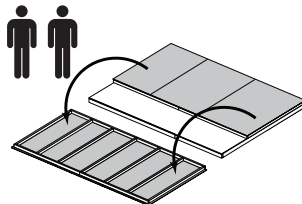

Repeat STEPS 1 - 6 to build second side wall.



Your side walls are now assembled.

BACK WALL FRAME

PARTS REQUIRED:

x3 **UM**
2 x 4 x 68" (5,1 x 10,2 x 172,7 cm)

x2 **SZ**
2 x 4 x 89" (5,1 x 10,2 x 226,1 cm)

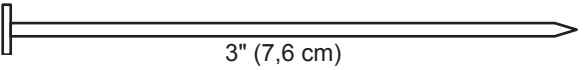
x12  3" (7,6 cm)



BEGIN

- 1 Orient parts on edge on floor. Measure and mark.
Secure with (2) 3" nails at each mark.

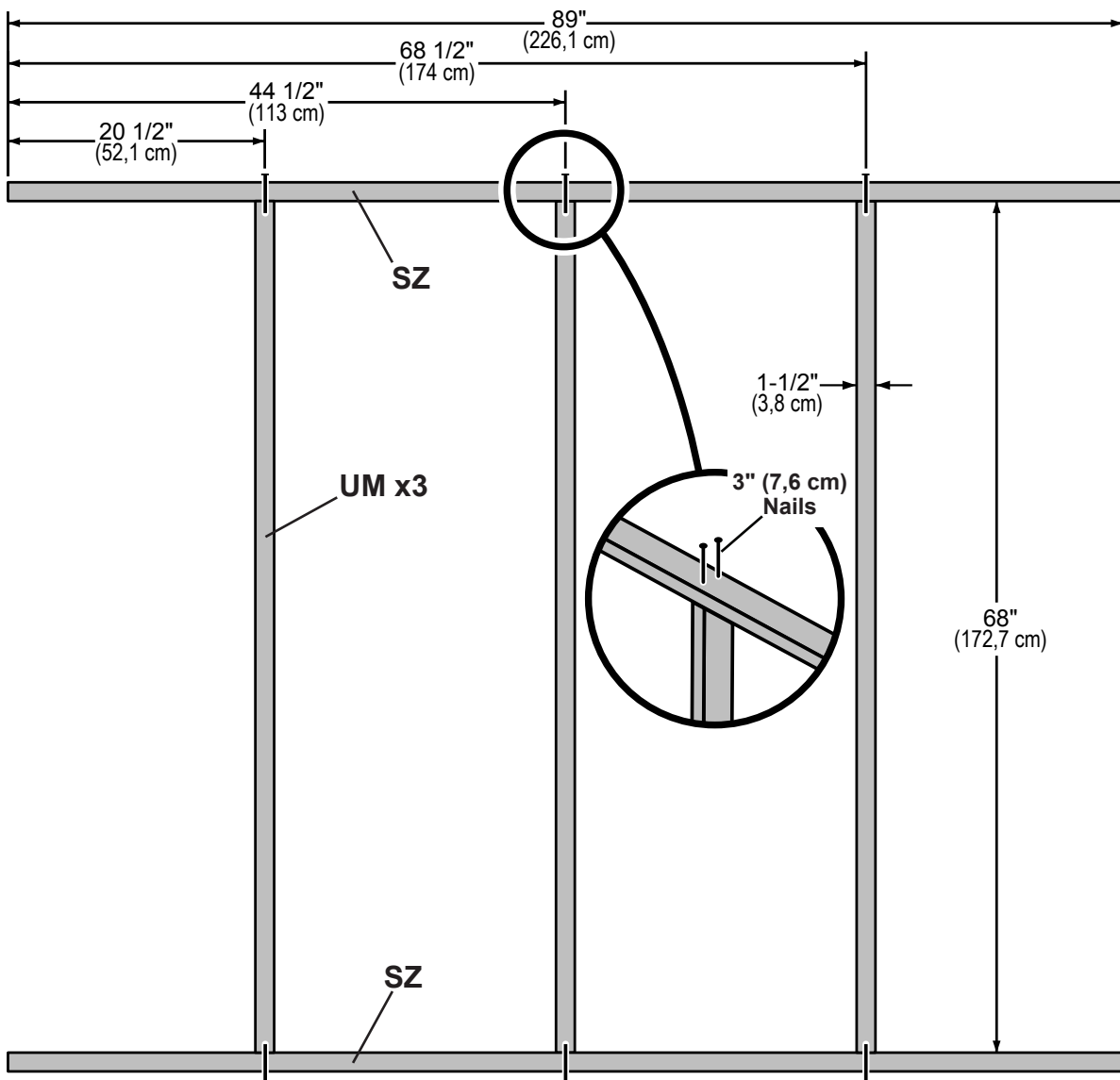
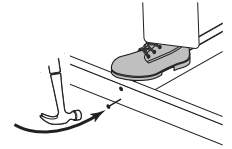

BACK WALL PANELS

PARTS REQUIRED:

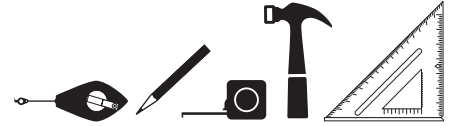
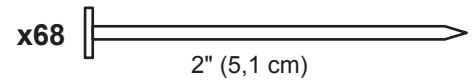
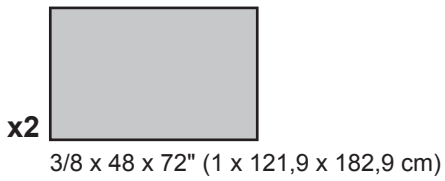

- Install 48" x 72" wall panels with primed side up as shown.
Secure panels to frame with 2" nails 6" apart along edges and 12" apart on inside of panel.

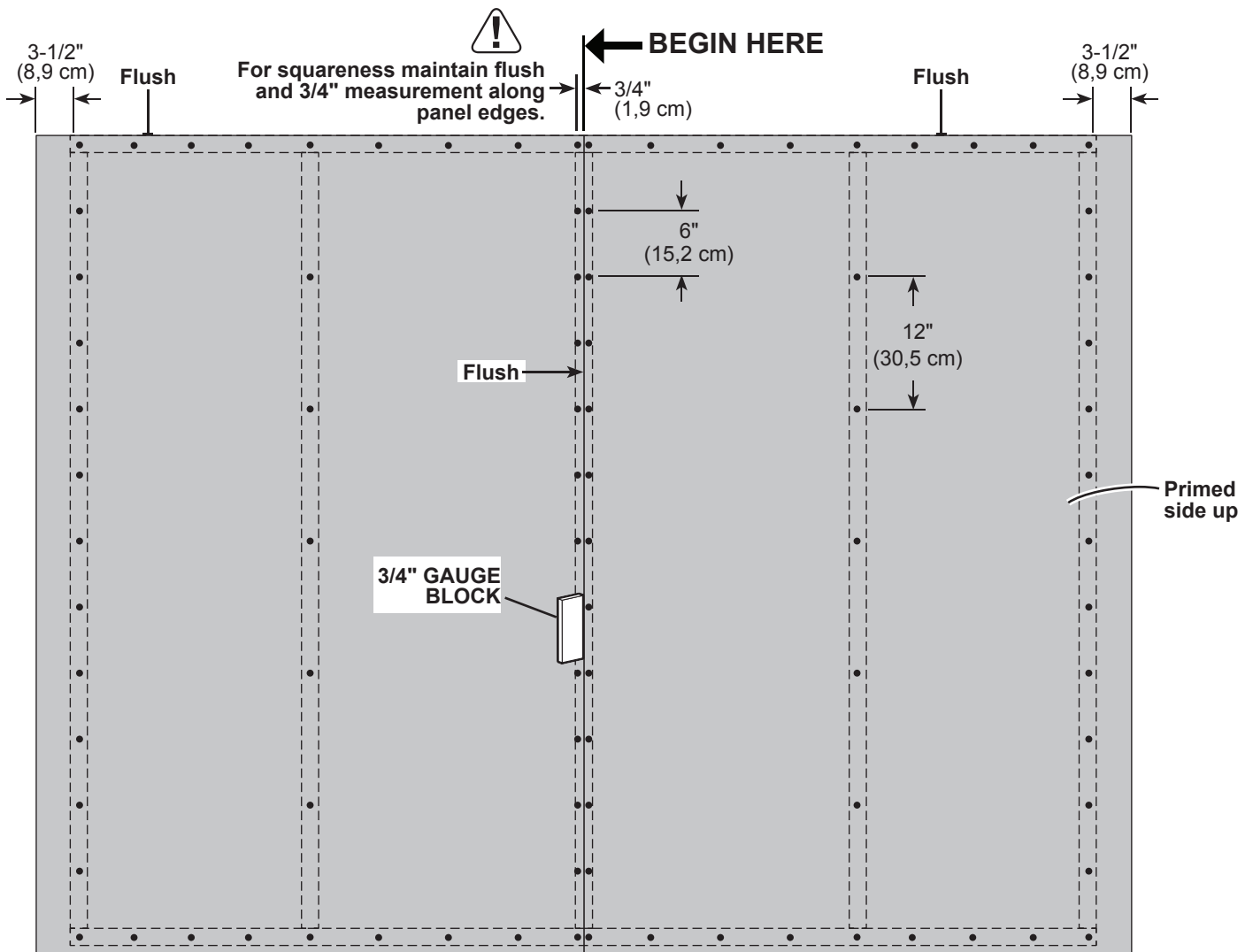

Your back wall is now assembled.

FRONT WALL

PARTS REQUIRED:

x2 **RD**
2 x 4 x 16-1/2" (5,1 x 10,2 x 41,9 cm)

x2 **UM**
2 x 4 x 68" (5,1 x 10,2 x 172,7 cm)

x1 **SZ**
2 x 4 x 89" (5 x 10,2 x 226,1 cm)

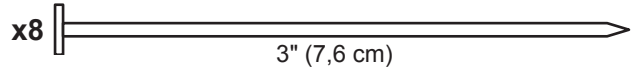

✓ BEGIN

- 1 Orient parts on edge on floor. Measure and mark.
- 2 Use (2) 3" nails at each mark.

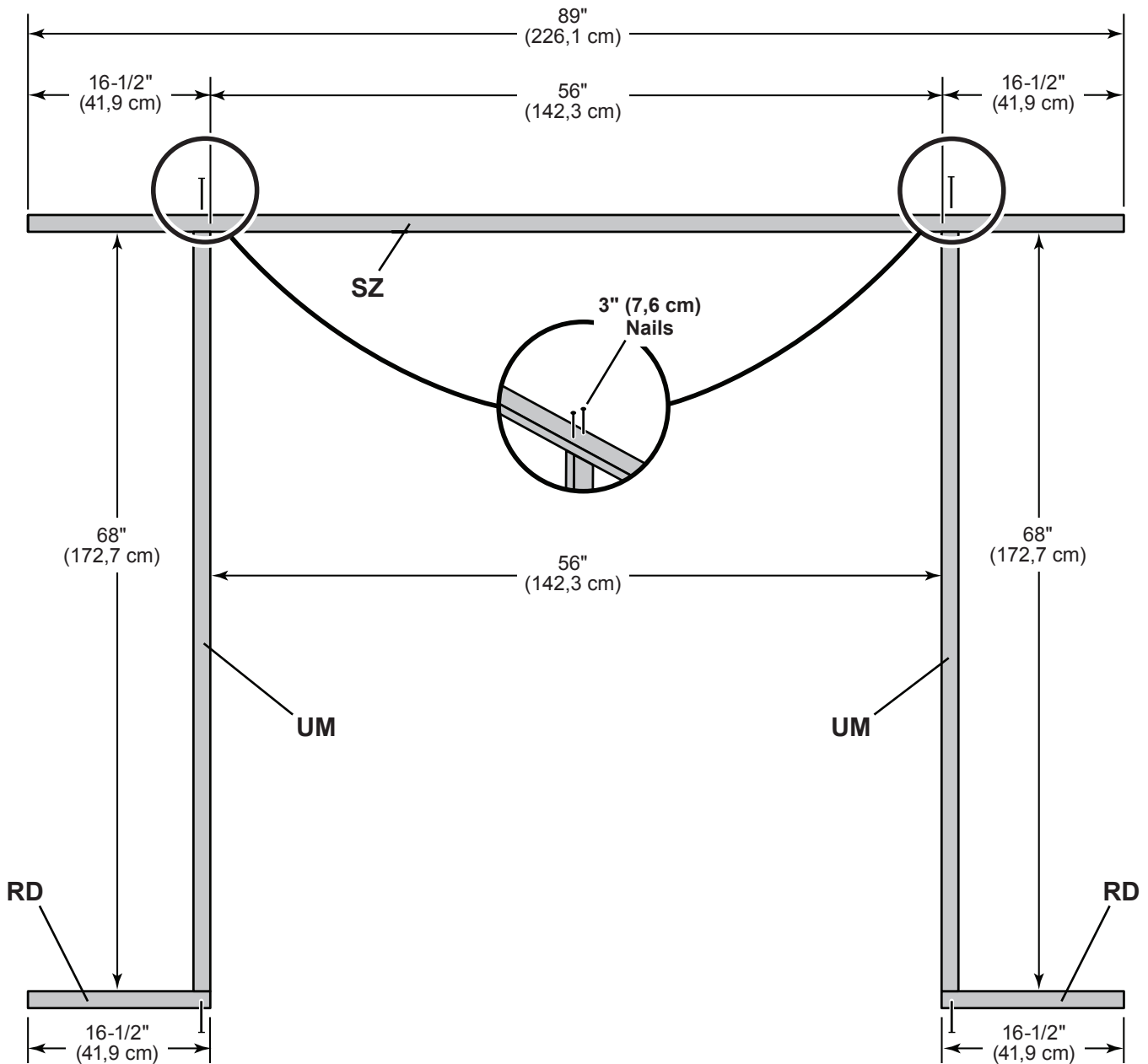
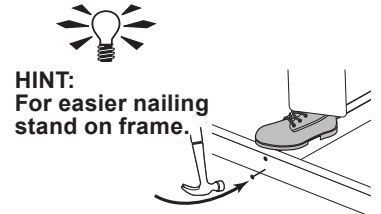

FRONT WALL

PARTS REQUIRED:

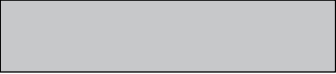
- x1 **OO**
1-1/4 x 2-1/2 x 69" (3,2 x 6,3 x 175,3 cm) *TEMPORARY SUPPORT*
- x2 
3/8 x 20 x 72" (1 x 50,8 x 182,9 cm)

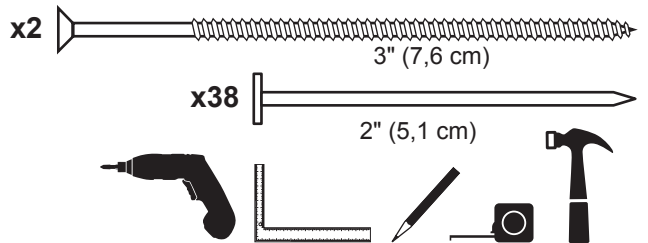

- 3** Place **20" x 72"** panels onto wall frame flush to **SZ** with primed side up as shown.
Secure panel with 2" nails 6" apart.
- 4** Install **OO** as a brace to maintain 56" (142,3 cm) opening. Use (2) 3" screws to attach.

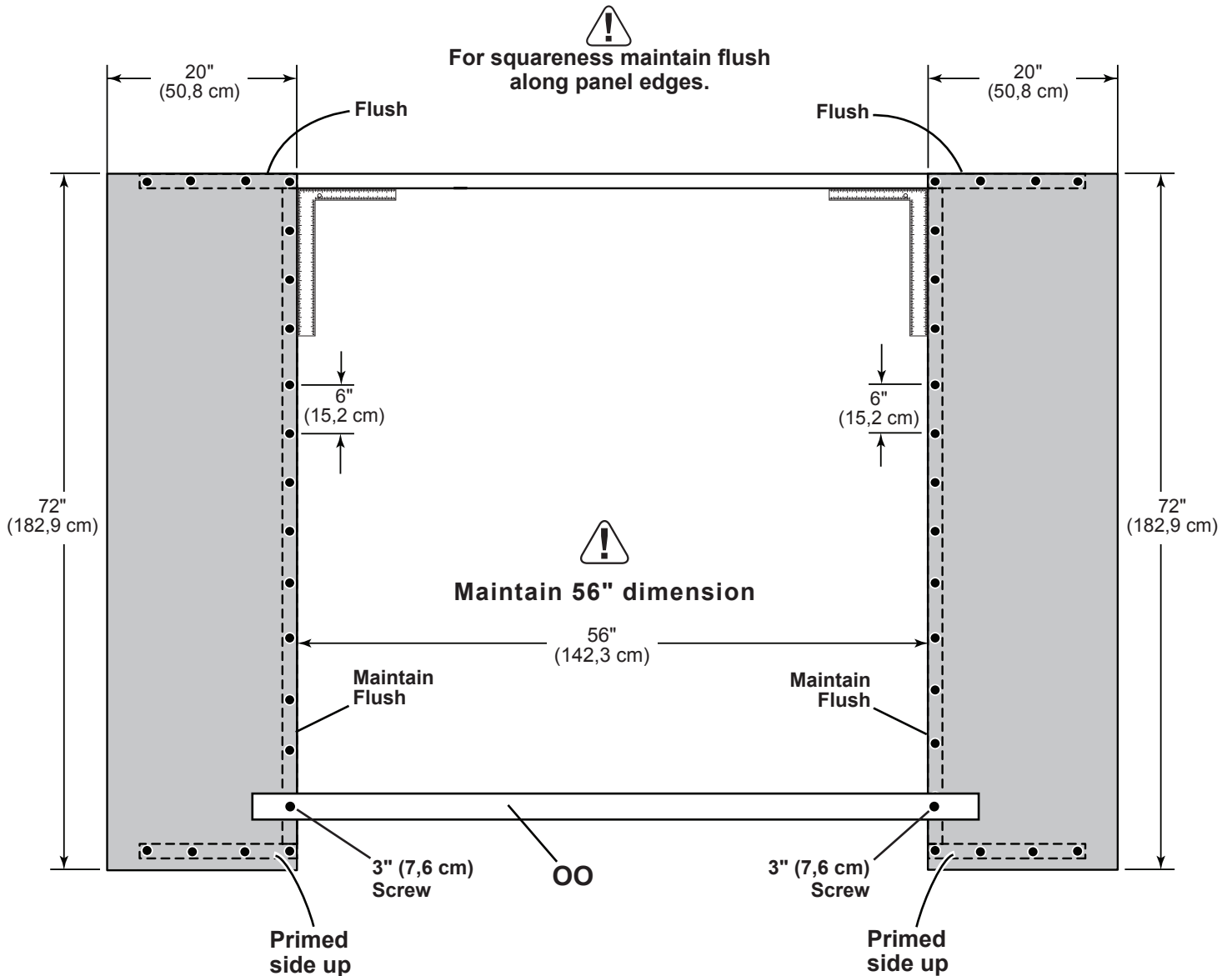

FRONT WALL

PARTS REQUIRED:

x1 **OY**
2 x 3 x 72" (5,1 x 7,6 x 213,4 cm)

x5  3" (7,6 cm)

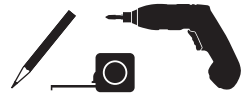

- 5** Center **OY** on **SZ** flush to edge of panel (**Fig. A, B**).
Secure with (5) 3" screws spaced evenly and screwed-in at an angle.

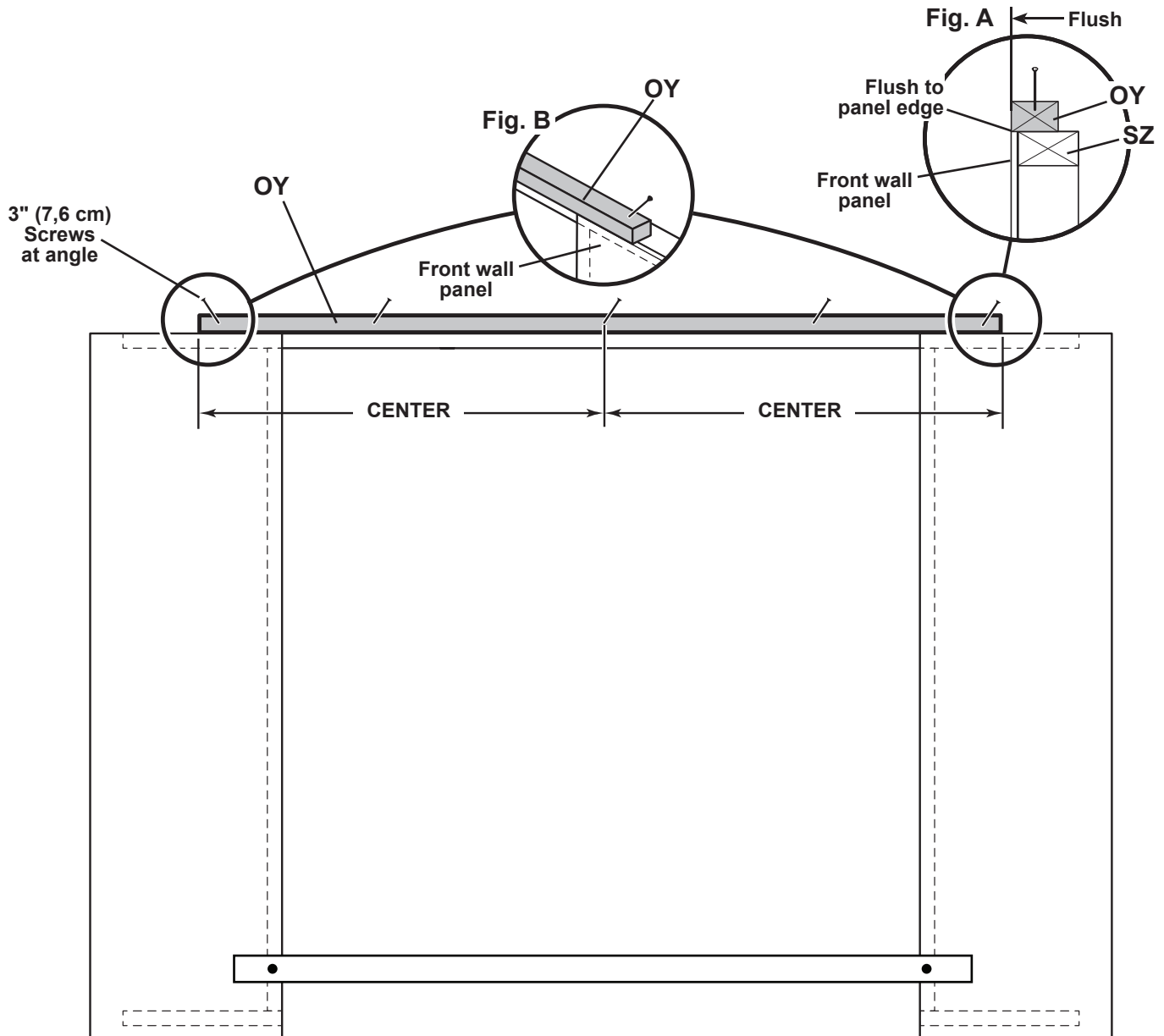

Your front wall is now assembled.

RIGHT SIDE WALL INSTALLATION

PARTS REQUIRED:

x1 **OO**
1-1/4 x 2-1/2 x 69" (3,2 x 6,3 x 175,3 cm)



x12 3" (7,6 cm)
x2 3" (7,6 cm)
x27 2" (5,1 cm)

✓ BEGIN

- Center 12' right side wall on the 141" (358,1 cm) floor dimension.
1" (2,5 cm) overlap is to the bottom.

Use **OO** as a temporary brace.
Secure with (2) 3" screws.

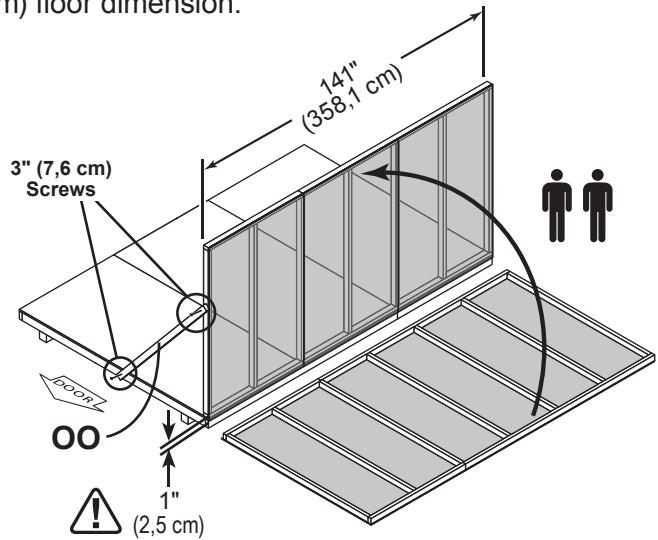

- First, nail lower edge of panel to floor frame with 2" nails 6" apart.
Angle nail to hit floor frame (**Fig. A**).

- Secure wall bottom plates to floor with 3" nails (**Fig. A**).

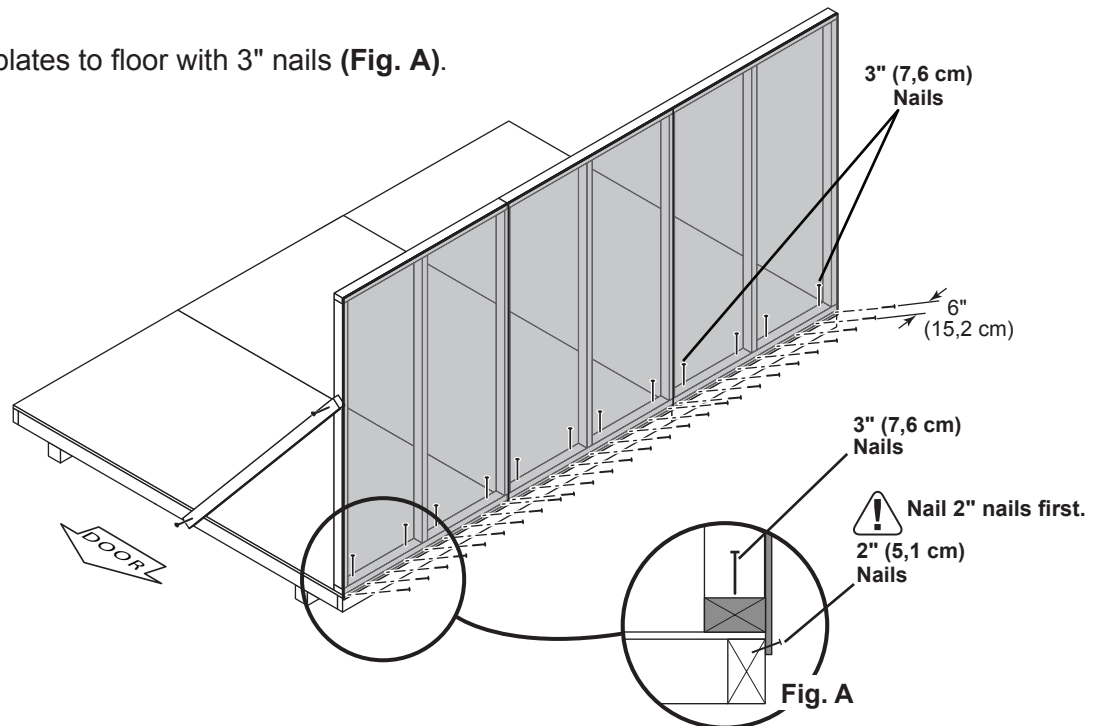

You have finished standing your right side wall.

BACK WALL INSTALLATION

PARTS REQUIRED

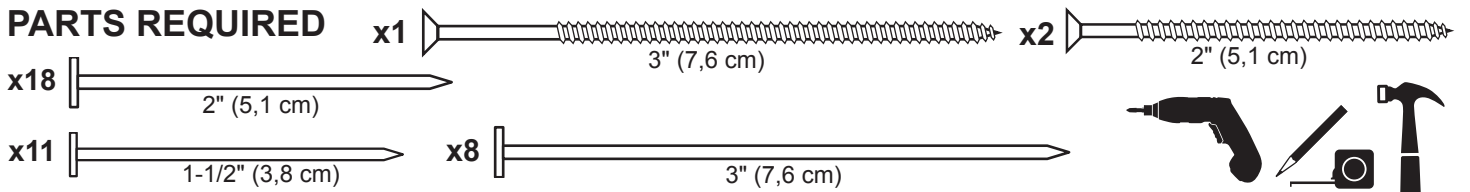

✓ BEGIN

- 1 Place back wall centered on floor.
 Secure wall with (1) 2" screw into side wall bottom plate (**Fig. A**) and top plate (**Fig. B**).

Secure wall to bottom plate first.

⚠ ENSURE PANEL CORNERS ARE FLUSH.

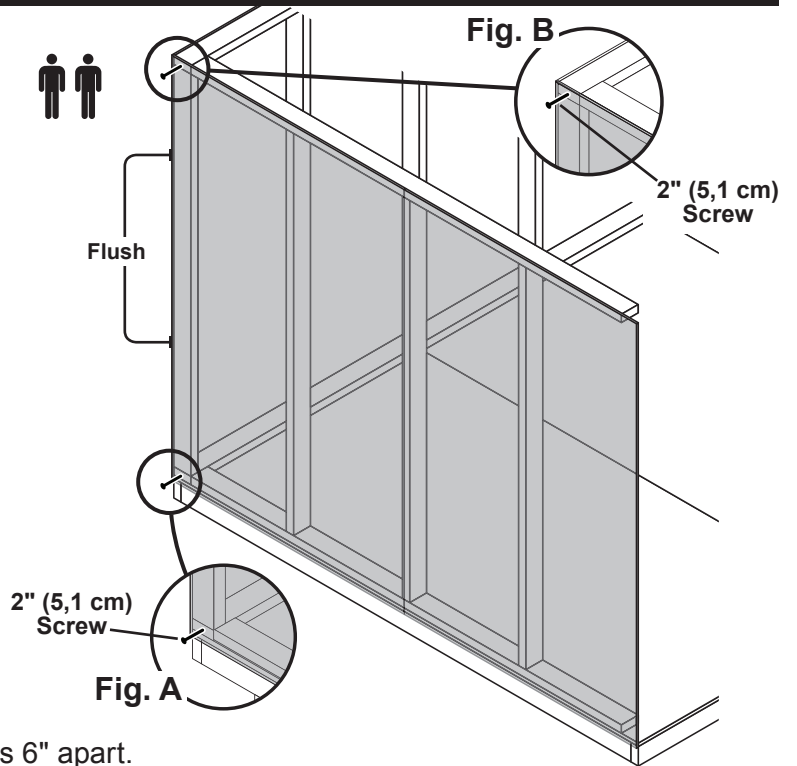

- 2 Nail lower edge of panels to floor with 2" nails 6" apart.
 Angle nail to hit floor frame (**Fig. C**).

Secure wall bottom plates to floor with 3" nails (**Fig. C**).

Nail panel to side wall stud with 1-1/2" nails.

- 3 Secure wall top plate with (1) 3" screw toe-screwed at the corner at an angle as shown in (**Fig. D**).

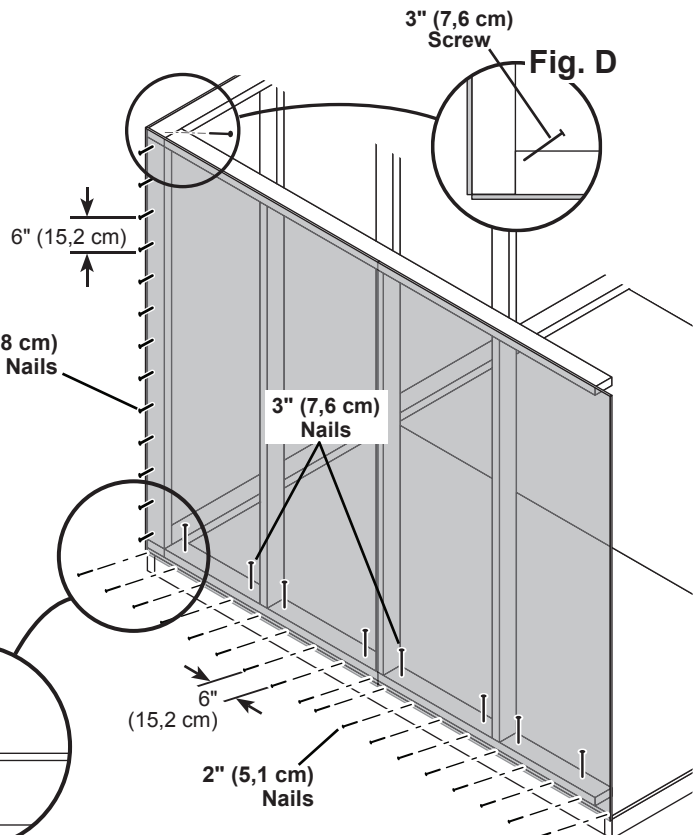

Your back wall is now installed.

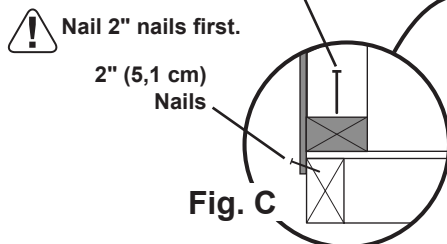

LEFT SIDE WALL INSTALLATION

PARTS REQUIRED:

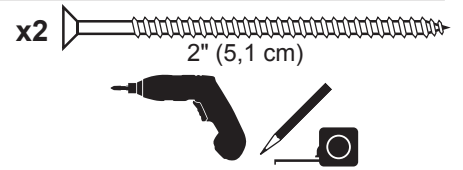

✓ BEGIN

- 1 Center left side wall on the 141" (358,1 cm) floor dimension.

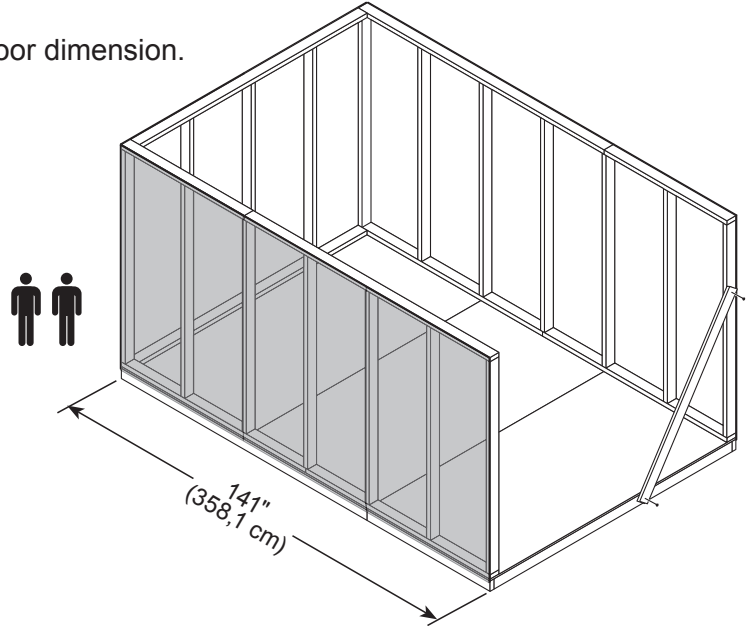

- 2 Secure wall with (1) 2" screw through back wall panel into side wall bottom and top plates (Fig. B, Fig. A).

Secure wall to bottom plate first.

⚠ ENSURE PANEL CORNERS ARE FLUSH.

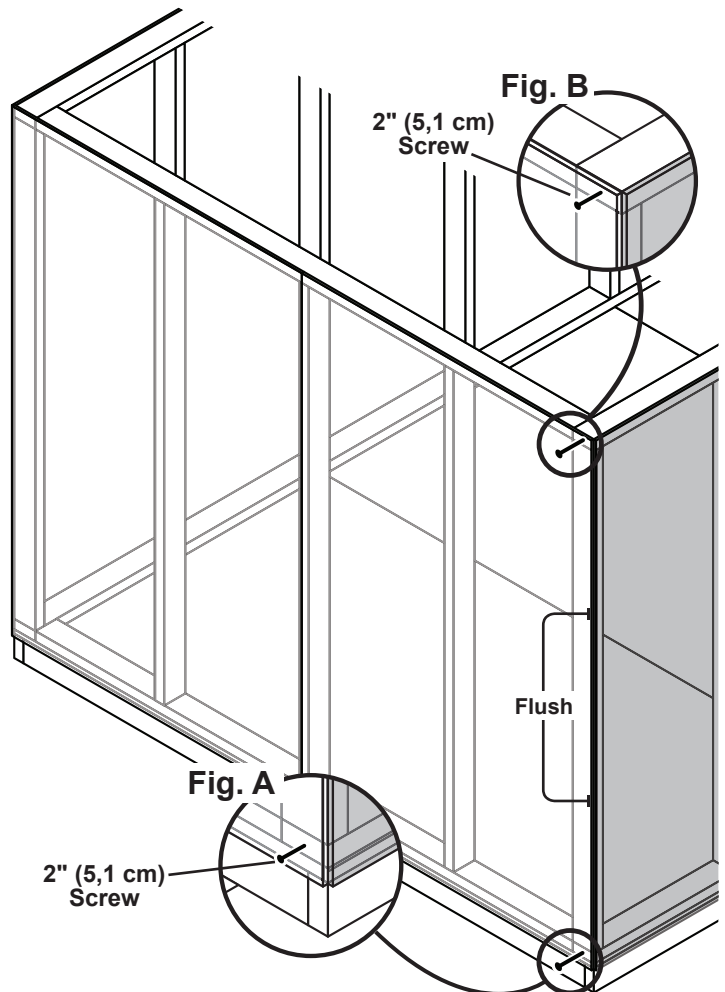

LEFT SIDE WALL INSTALLATION

PARTS REQUIRED:

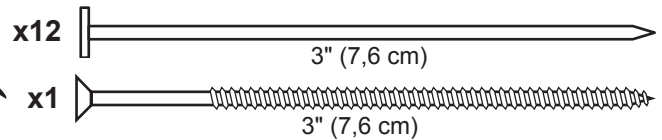
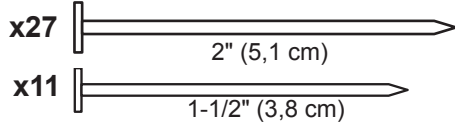

- 3 Nail lower edge of side wall panels to floor frame with 2" nails 6" apart. Angle nail to hit floor frame (**Fig. C**).

Secure wall bottom plates to floor with 3" nails (**Fig. C**).

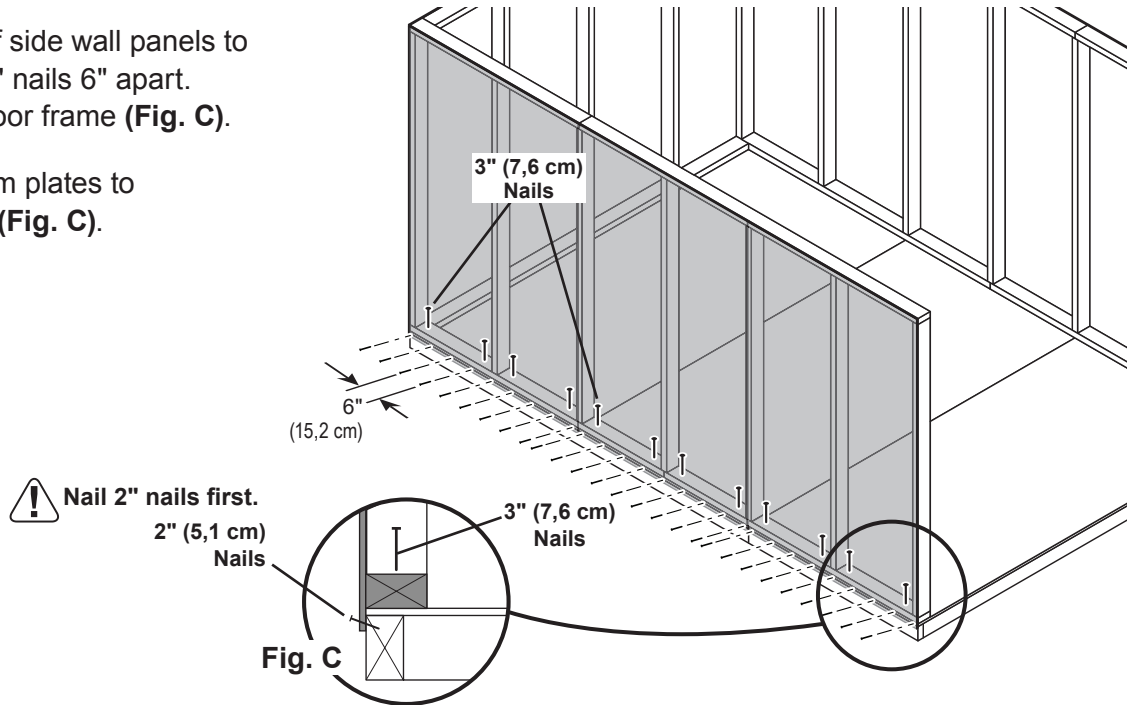

- 4 Nail back wall panel to side wall stud with 1-1/2" nails 6" apart.

- 5 Secure gable wall top plate with (1) 3" screw toe-screwed at the corner at an angle as shown (**Fig. D**).

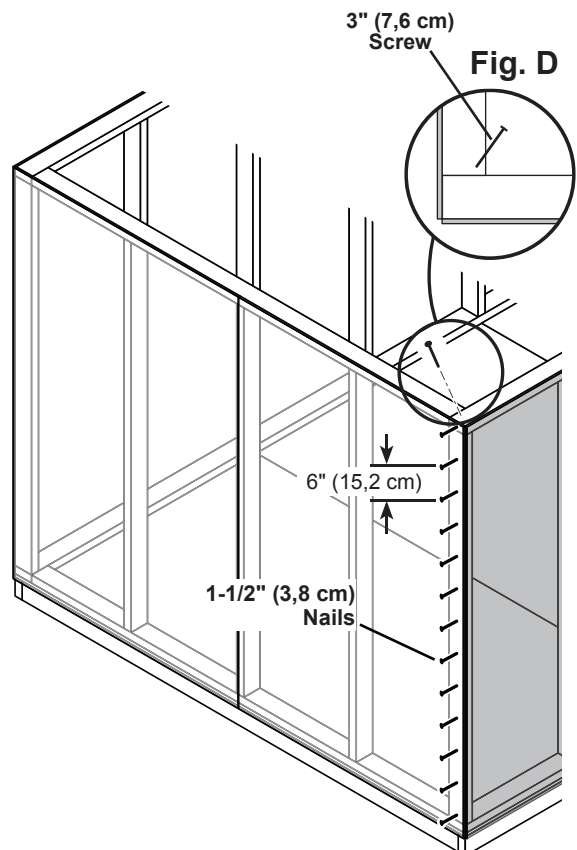

Your left side wall is now installed.

FRONT WALL INSTALLATION

PARTS REQUIRED

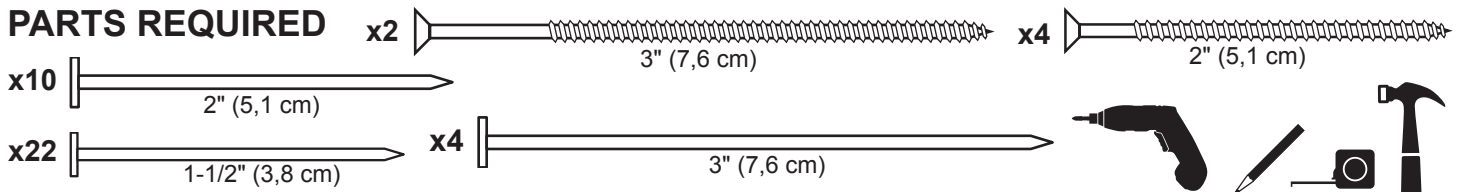

✓ BEGIN

1 Place front wall on floor centered between side walls.

Secure wall with 2" screws into top and bottom plates (**Fig. A, Fig. B**).

Secure wall to bottom plate first.

⚠ ENSURE PANEL CORNERS ARE FLUSH. ⚠

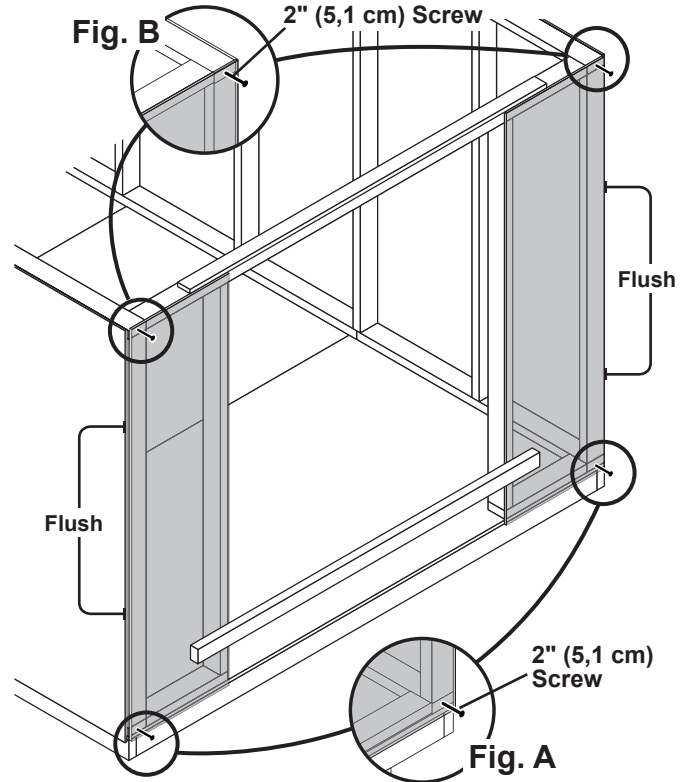

2 Nail lower edge of panels to floor with 2" nails 6" apart. Angle nail to hit floor frame (**Fig. C**).

Nail panels to both side wall studs with 1-1/2" nails.

Secure wall bottom plates to floor with 3" nails (**Fig. C**).

3 Secure top plates with 3" screws toe-screwed at each corner at an angle as shown in (**Fig. D**).

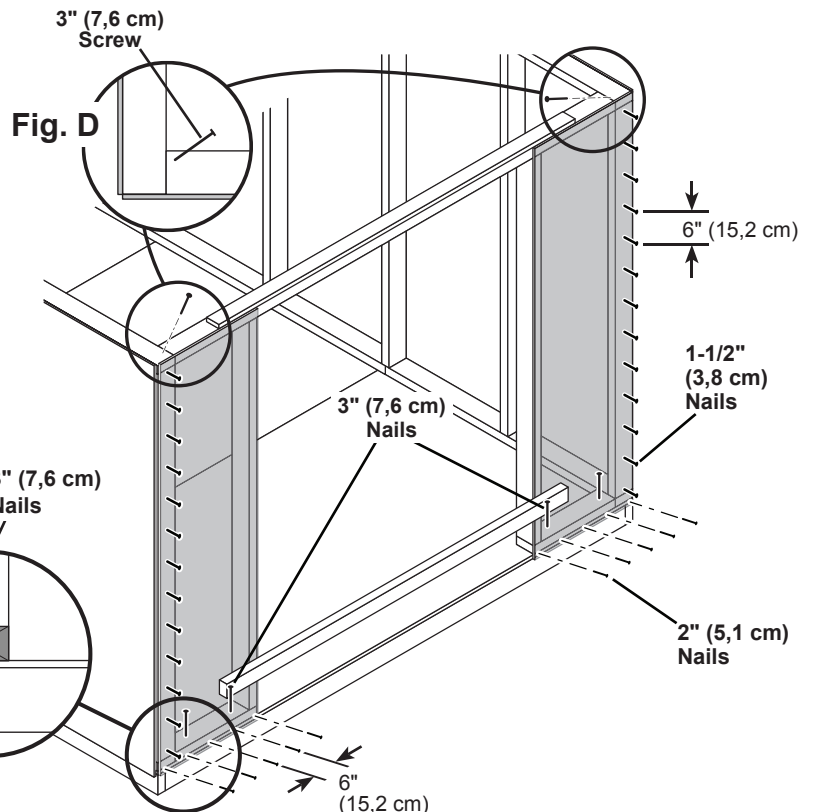

REMOVE TEMPORARY BRACING

⚠ Nail 2" nails first.
2" (5,1 cm) Nails



Fig. C





Your front wall is now installed.

RAFTERS

PARTS REQUIRED: x2

x11  OSB OR WOOD GRAIN 
7-1/4 x 18-1/4" (18,4 x 46,4 cm)

x12  PGA
2 x 4 x 68-7/16" (5,1 x 10,2 x 173,2 cm)

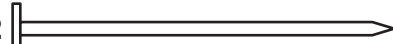
x132  3" (7,6 cm) x132  2" (5,1 cm)

TEMPORARY SUPPORT
x2  AYB 2 x 6 x 5-1/4"
(5,1 x 15,2 x 13,3 cm)

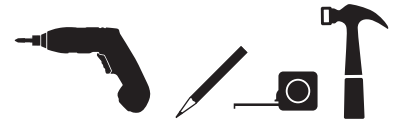

You will build SIX assemblies. (5) with two gussets, and (1) with one gusset.

✓ BEGIN

1 Place **AYB** against back wall at measurement shown.
Secure **AYB** with (2) 3" screws as shown.



HINT:

Use floor and walls to help assemble rafters!

2 Place two rafter halves **PGA** in the corner of back and side wall and **AWB**. Flush rafters at peak.

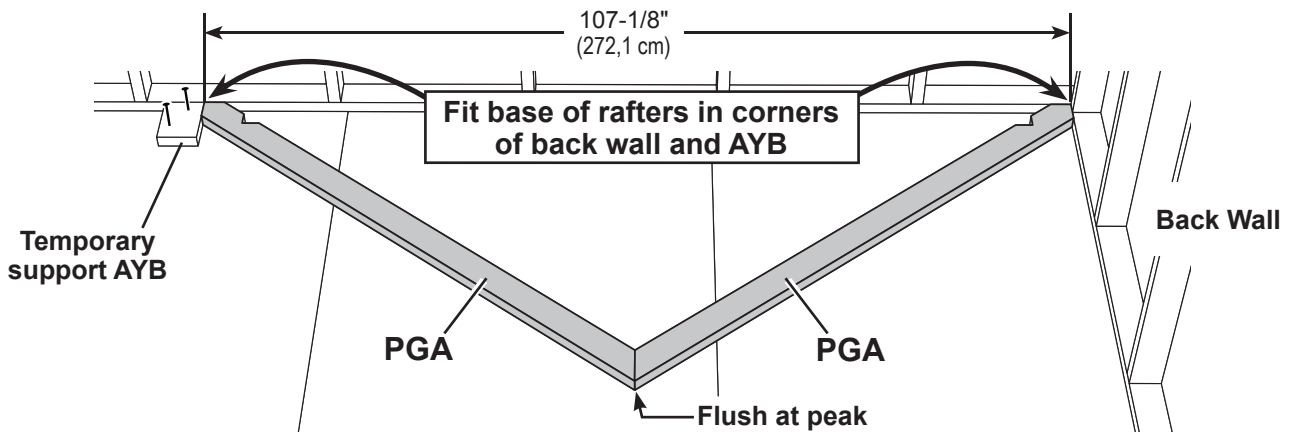

3 Secure gusset to rafters with (12) 2" nails as shown.

 SET ASIDE ONE RAFTER ASSEMBLY WITH ONLY ONE GUSSET ATTACHED.

4 Flip over rafter assembly and repeat STEP 2 - 3 to attach second gusset to other side.

Repeat STEPS 2 - 4 to build four additional rafter assemblies.

Leave **AYB** attached to floor, it will be used later.

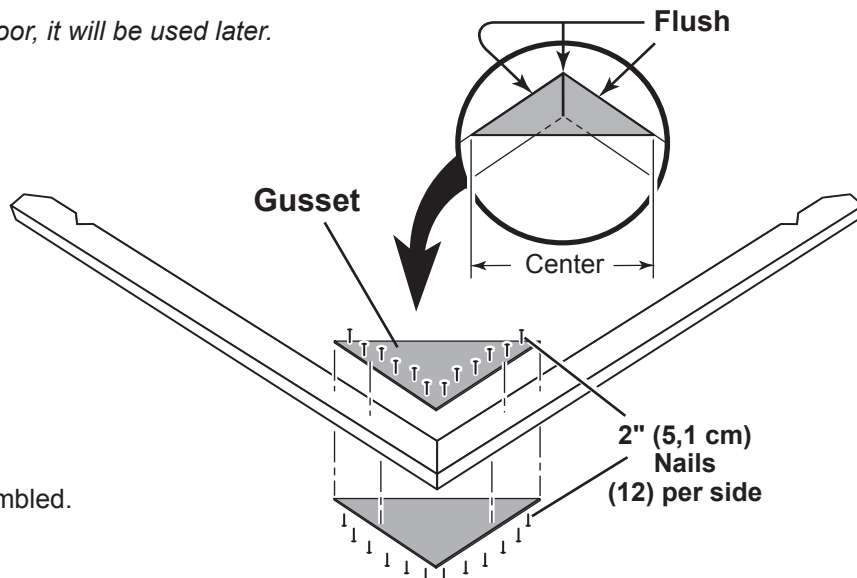

FINISH
Your rafters are now assembled.

RAFTER INSTALL

PARTS REQUIRED:

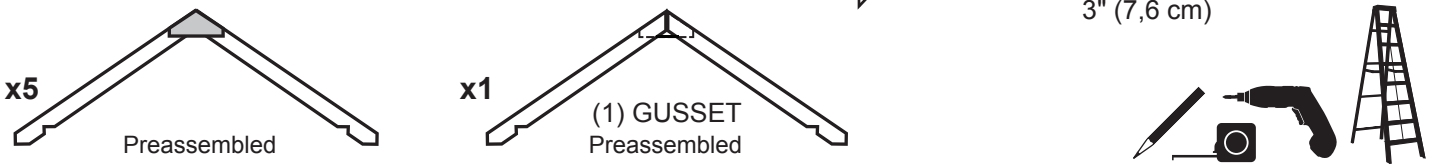

✓ **BEGIN**

1 Secure rafters to top plate with (2) 3" screws in each rafter (Fig. A, Fig. B).



Note single-gusset rafter at back wall with gusset facing inward.

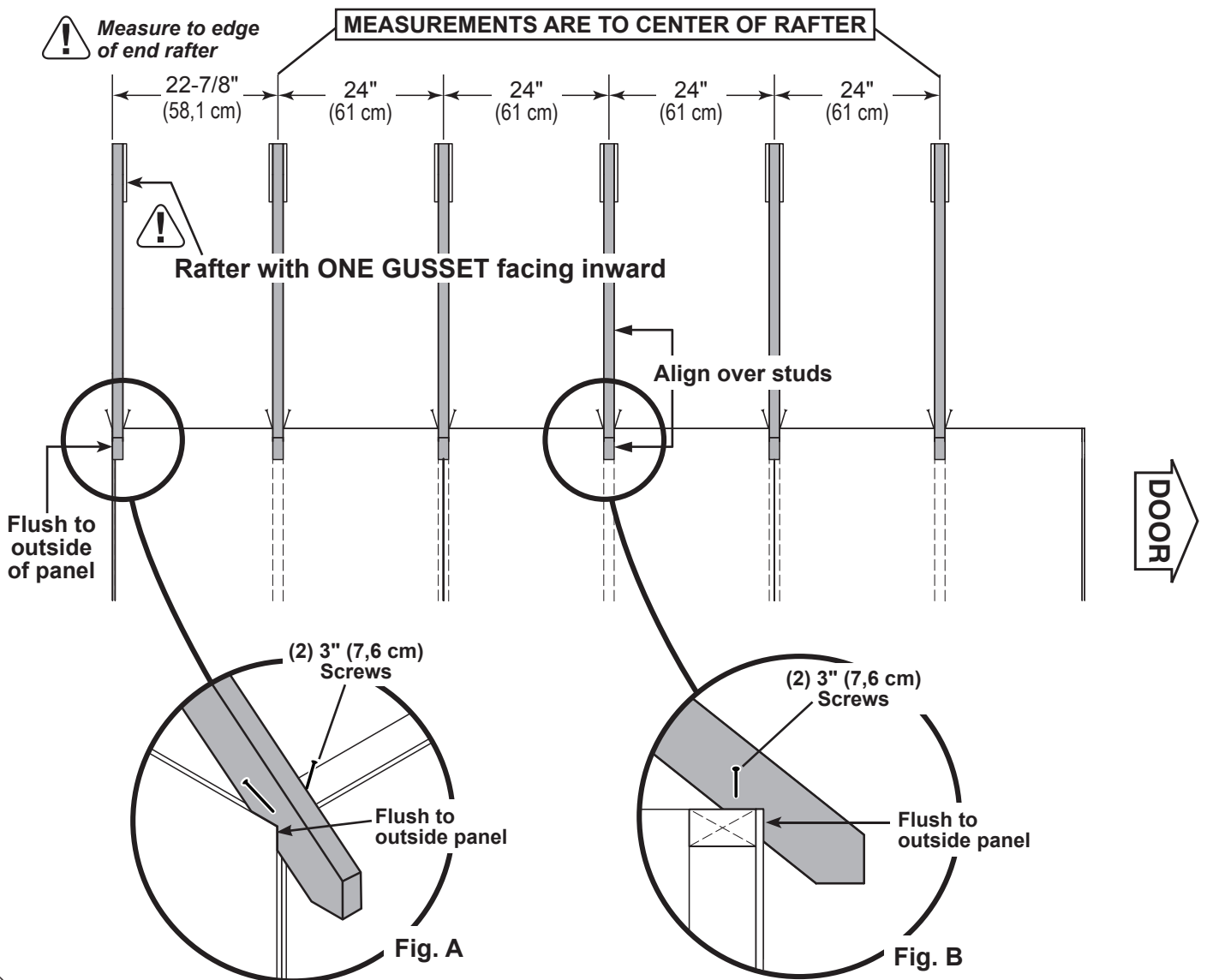

FINISH

Your rafters are now installed.

BACK GABLE UNIT

PARTS REQUIRED:

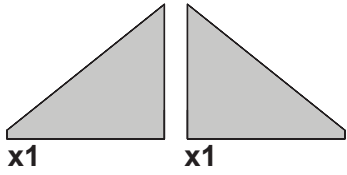

x1 **RLB**
2 x 4 x 35-3/16"
(5,1 x 10,2 x 89,4 cm)

x10 1-1/2" (3,8 cm)

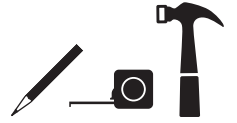

✓ **BEGIN**

- 1 Orient **RLB** on flat as shown.
Place left gable panel as shown. Secure with 1-1/2" nails as shown.

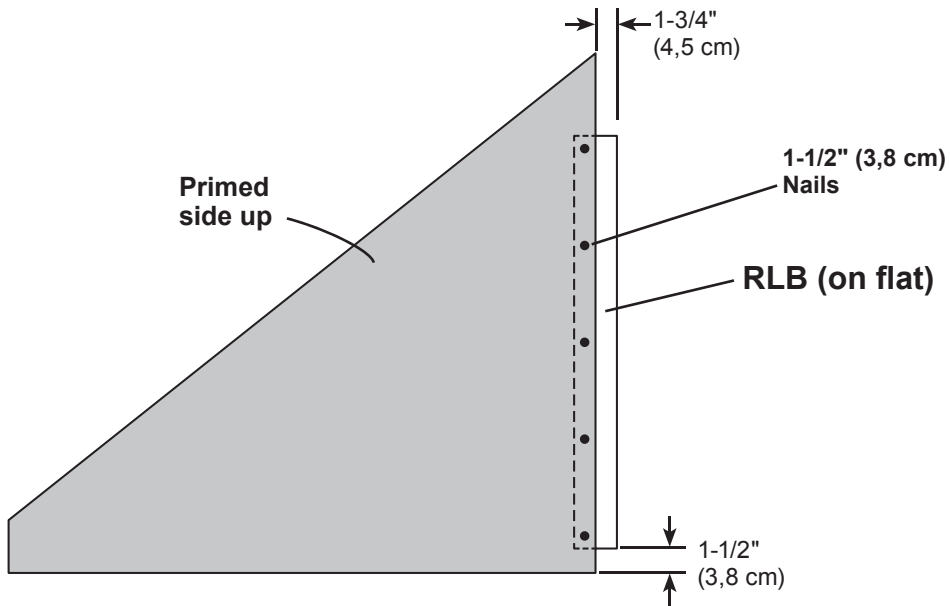

- 2 Place right gable panel flush to left panel. Secure with 1-1/2" nails as shown.

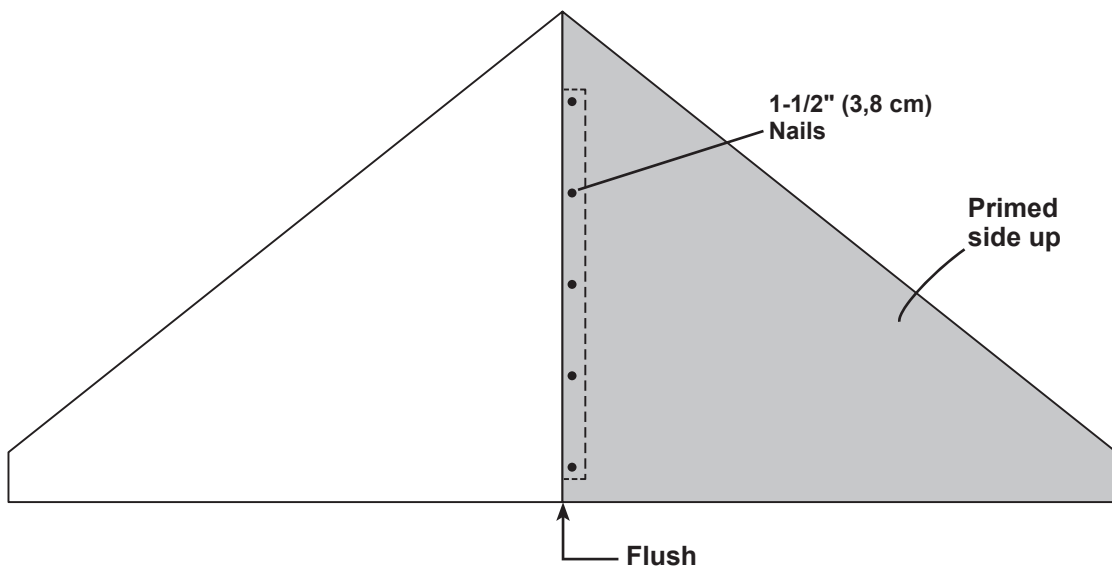

FINISH

Your back gable unit is now assembled.

BACK GABLE UNIT INSTALLATION

PARTS REQUIRED:

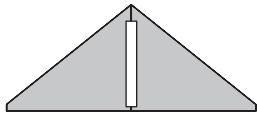
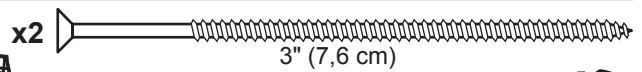
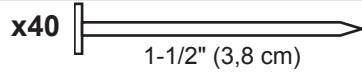

Back Gable Unit



✓ BEGIN



- 1 Install back gable unit on back wall top plate. Measure 1-1/2" down from top plate and mark at each side as shown. Set gable unit on top plate. Hold secure with (1) 1-1/2" nail on each side.

⚠ BE SURE GABLE IS CENTERED ON WALL BEFORE NAILING. ⚠

- 2 Continue nailing lower edge of panels into top plate with 1-1/2" nails 6" apart.

- 3 Secure panels to rafter with 1-1/2" nails 6" apart.

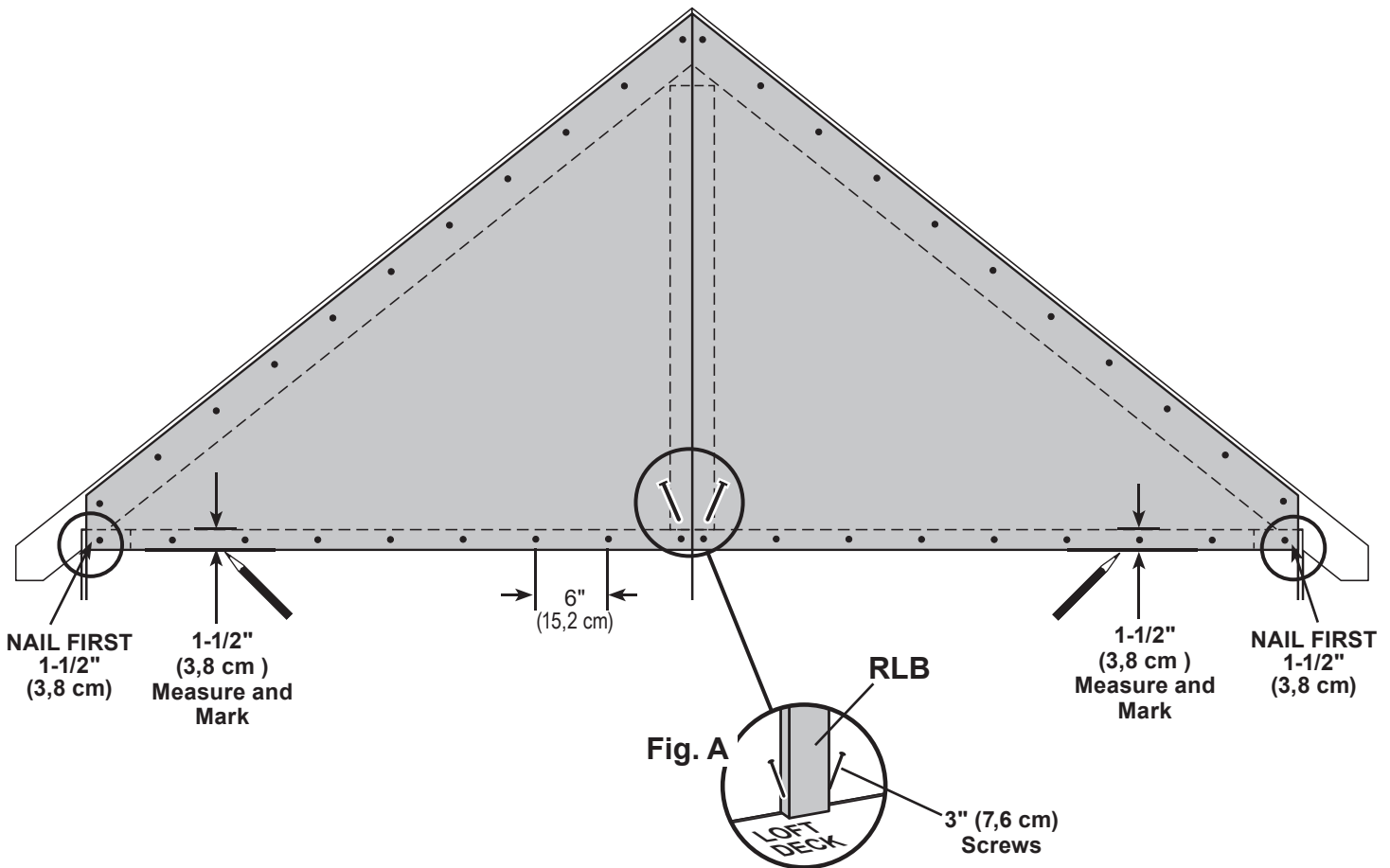

- 4 Working inside, secure gable unit with (2) 3" screws toe-screwed into RLB at an angle (Fig. A).



Your back gable unit is now installed.

FRONT GABLE UNIT

PARTS REQUIRED:

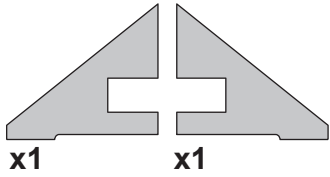

x1 **UY**
2 x 4 x 6-1/2"
(5,1 x 10,2 x 16,5 cm)

x1 **RH**
2 x 4 x 21-3/4"
(5,1 x 10,2 x 55,2 cm)

x12 1-1/2" (3,8 cm)

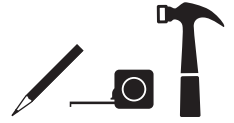

✓ **BEGIN**

- 1 Orient parts **UY** and **RH** on flat as shown.
Place left gable panel as shown. Secure with 1-1/2" nails as shown.

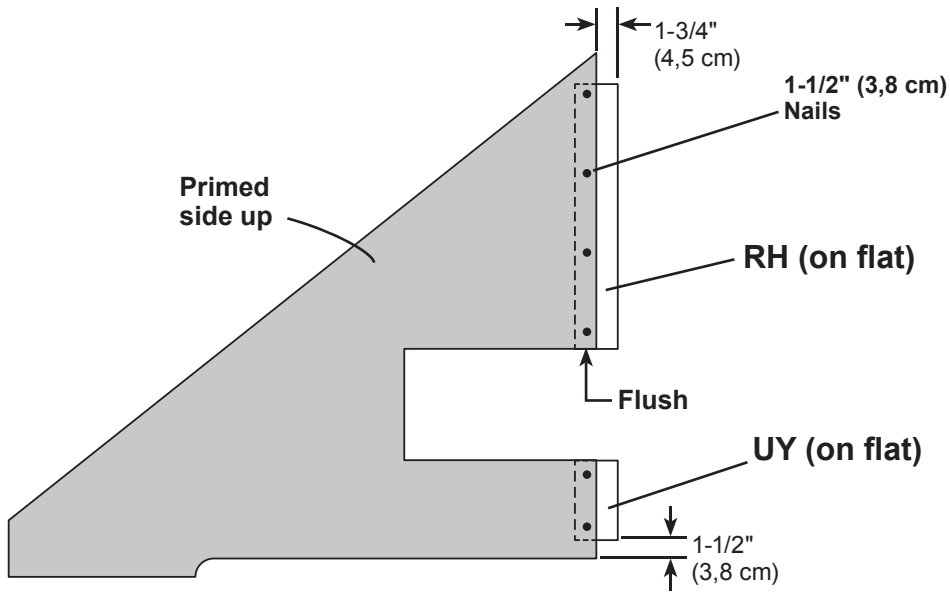

- 2 Place right gable panel flush to left panel. Secure with 1-1/2" nails as shown.

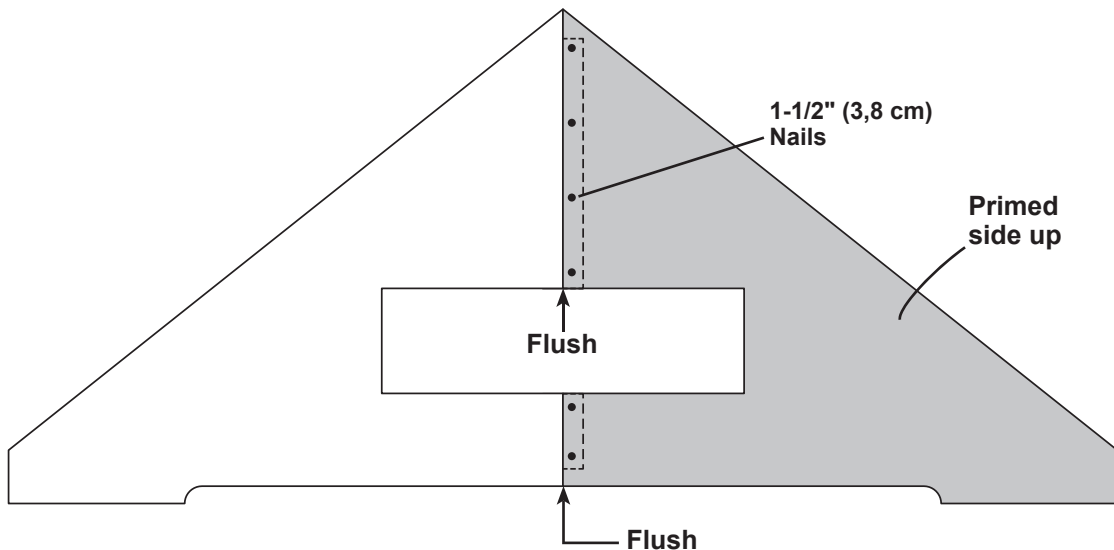

Your front gable unit is now assembled.

FRONT GABLE LADDERS

PARTS REQUIRED:

x4 **SXA**
 2 x 3 x 68-7/16" (5,1 x 7,6 x 173,8 cm)

x6 **URB**
 2 x 3 x 5-1/2" (5,1 x 7,6 x 14 cm)

x24  3" (7,6 cm)

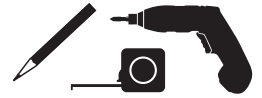

✓ BEGIN

- 1 Arrange, measure and mark locations of four **URB** as shown place **SXA** on top. Secure with 3" screws as shown (**Fig. A**). Ensure parts are flush along edges.

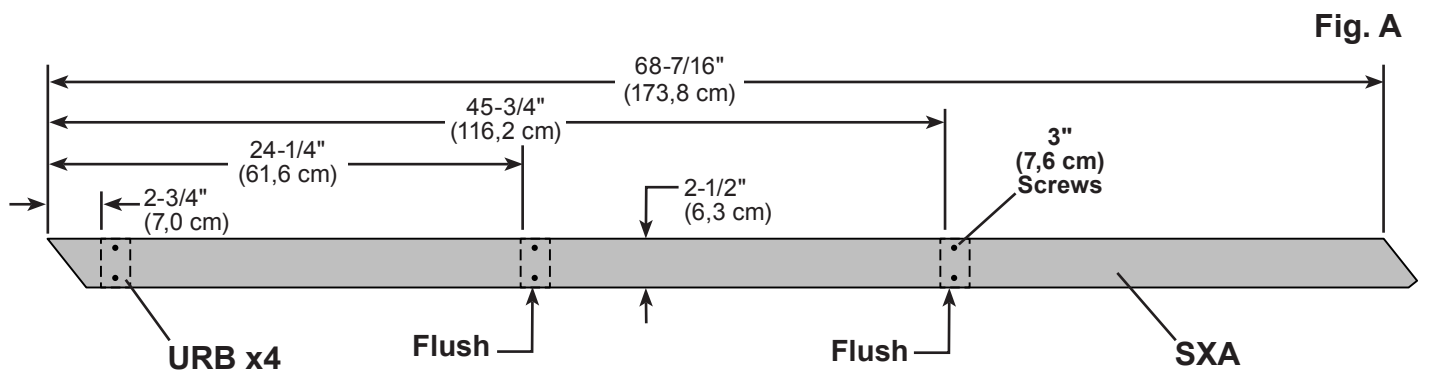

- 2 Flip over gable ladder sub-assembly and fasten **SXA** to (3) **URB** with 3" screws (**Fig. B**).

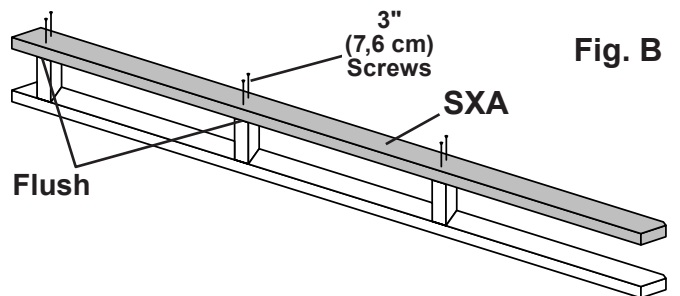

Repeat STEPS 1 - 2 to build the 2nd gable ladder.

FRONT GABLE UNIT

PARTS REQUIRED:

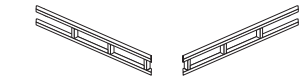

x2 Ladder Assemblies

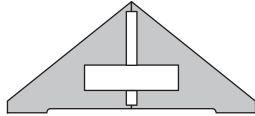

Front Gable Unit

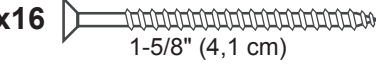
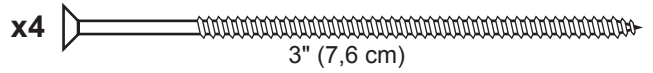

✓ BEGIN

- 1 Place ladder assemblies in rafter jig, flush into corner and flush to **AYB**.
Toe-screw ladder assemblies together with (4) 3" screws (**Fig. F**).

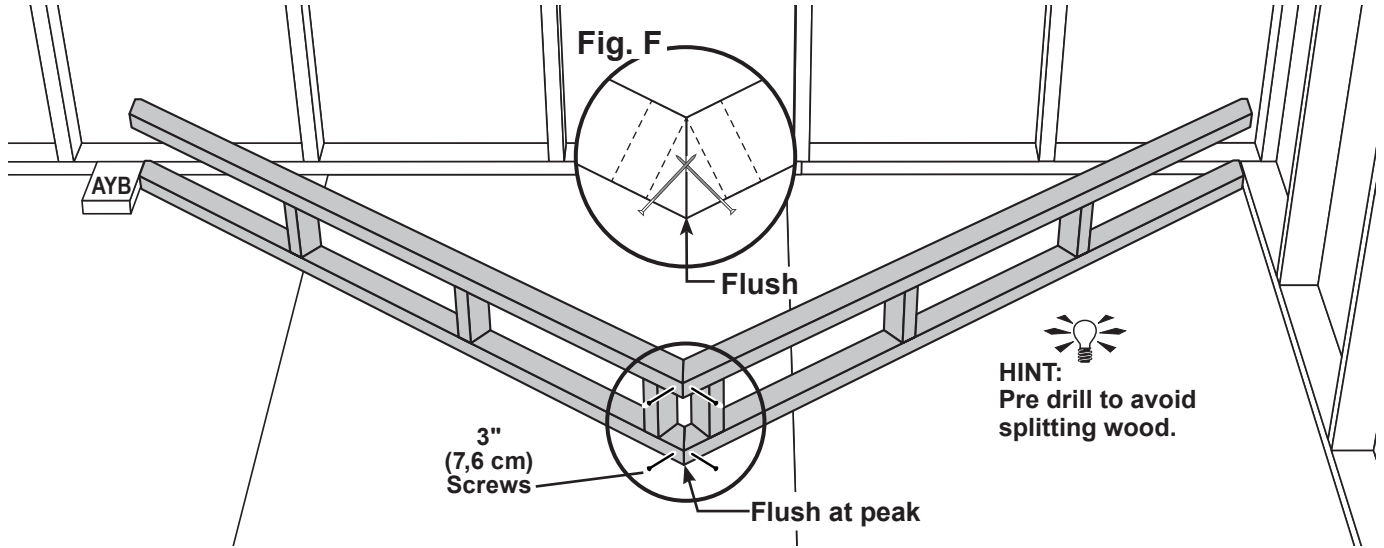

- 2 Place gable unit primed side down on gable ladders.
Ensure panels are flush at peak of ladder and flush along top edge of ladder assembly.
Fasten with 1-5/8" screws spaced evenly as shown (**Fig. G**).

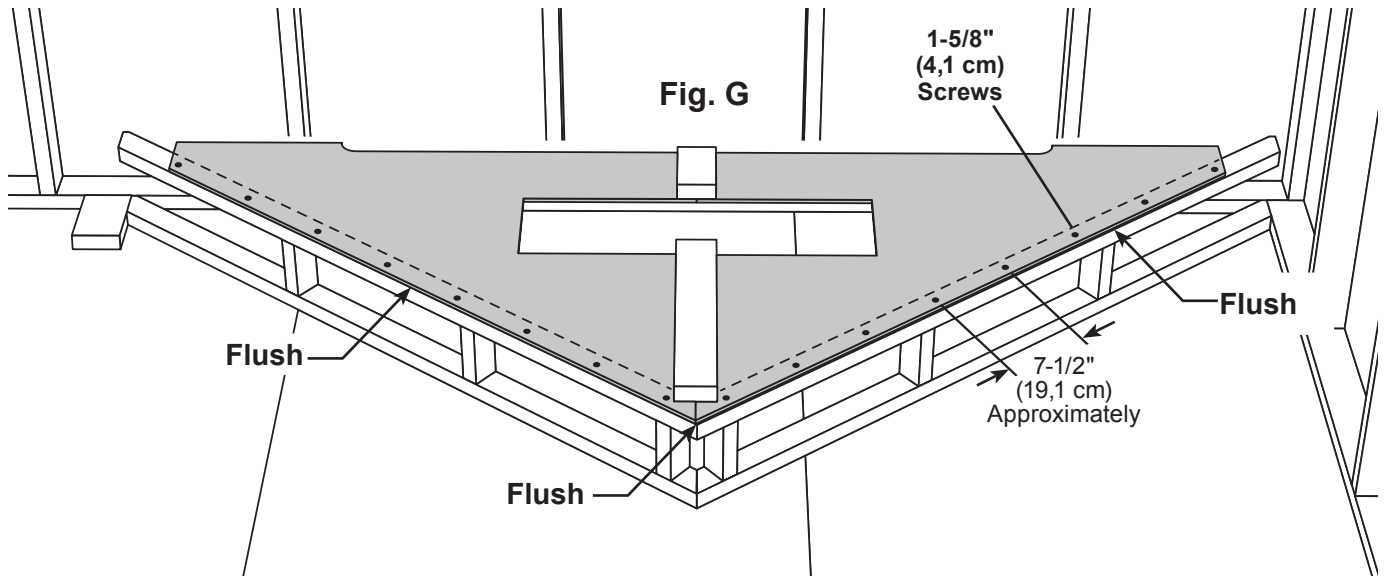

Your gable unit is assembled.

FRONT GABLE UNIT INSTALLATION

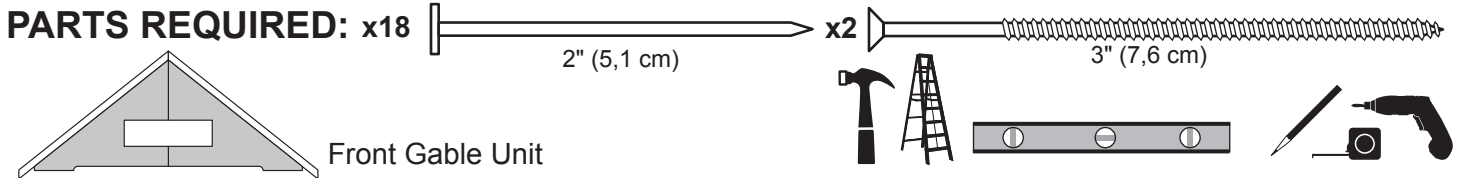

BEGIN



- 1 Install front gable unit on front wall top plate.
 - Measure 1-1/2" (3,8 cm) down from top plate and mark at each side as shown.
 - Set gable unit on top plate.
 - Hold secure with (1) 2" nail on each side.

BE SURE GABLE IS CENTERED ON WALL BEFORE NAILING.

Continue nailing lower edge of panels into top plate with 2" nails 6" apart.

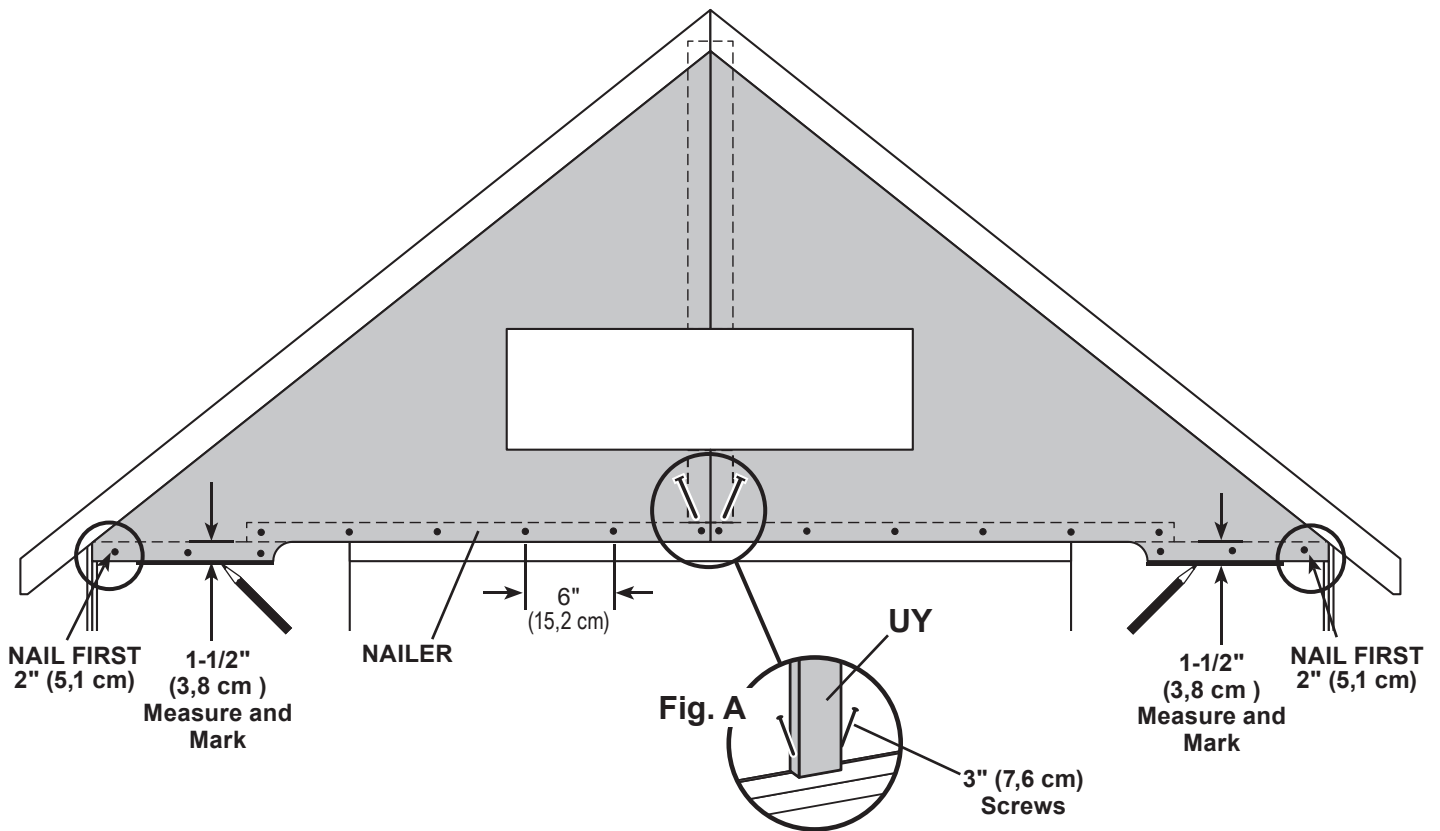

- 2 Working inside, secure gable unit with (2) 3" screws toe-screwed into **MHA** at an angle (**Fig. A**).



Your gable unit is installed.

FRONT GABLE L-blocks

PARTS REQUIRED:

x2 **LUA** 2 x 6 x 3-5/8" (5,1 x 15,2 x 9,2 cm)

x2 **AYB** 2 x 6 x 5-1/4" (5,1 x 15,2 x 13,3 cm)

x8  3" (7,6 cm)

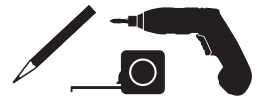

✓ **BEGIN**

1 Build two L-blocks by attaching **AYB** to **LUA** with (2) 3" screws (**Fig. A**).

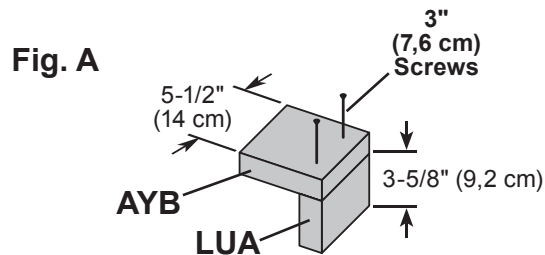

HINT:
Pre drill to avoid splitting wood.

2 Ensure each L-block is in the correct position using a level, as shown in **Fig. B**.

Pre-drill all holes.

Secure each L-block with (4) 3" screws, as shown (**Fig. C**).

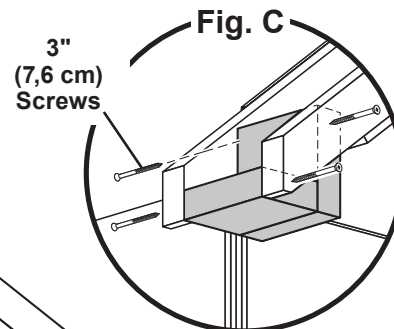
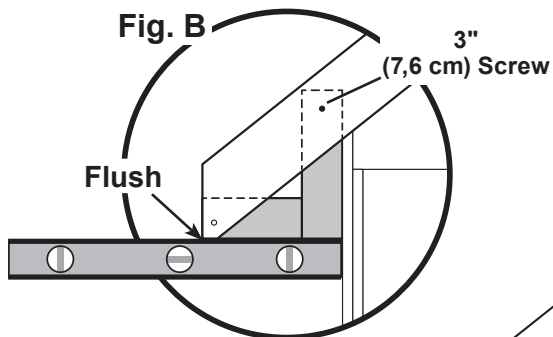

HINT:
Pre drill to avoid splitting wood.

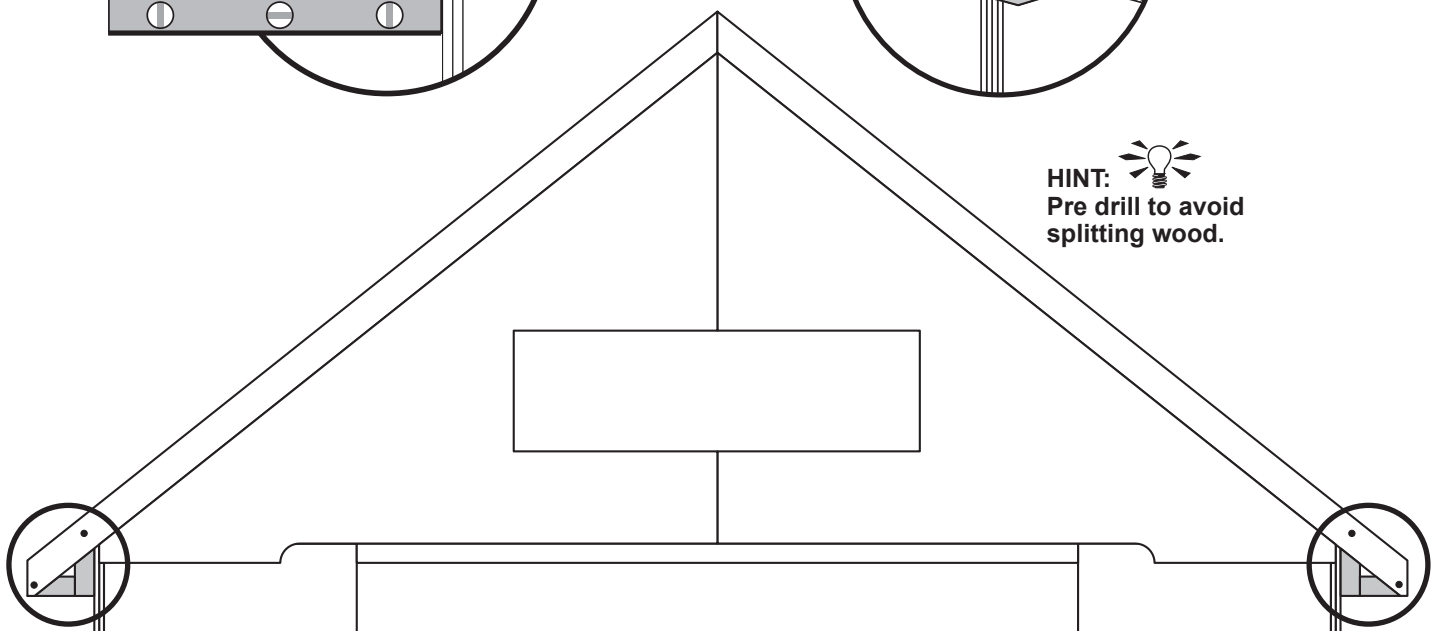

FINISH

Your L-blocks are installed.

FRONT OVERHANG SOFFIT

PARTS REQUIRED:

x2 
3/8 x 8-1/2 x 61-5/16" (1 x 21,6 x 155,7 cm)



x20 
1-1/4" (3,2 cm)



 **Ensure overhang boards meet at peak (Fig. A).** 

✓ **BEGIN**

1 Position **61-5/16"** overhang boards flush at peak, primed side down and flush to wall panels (**Fig A**).

Secure panels to frame with (20) 1-1/4" screws spaced evenly.

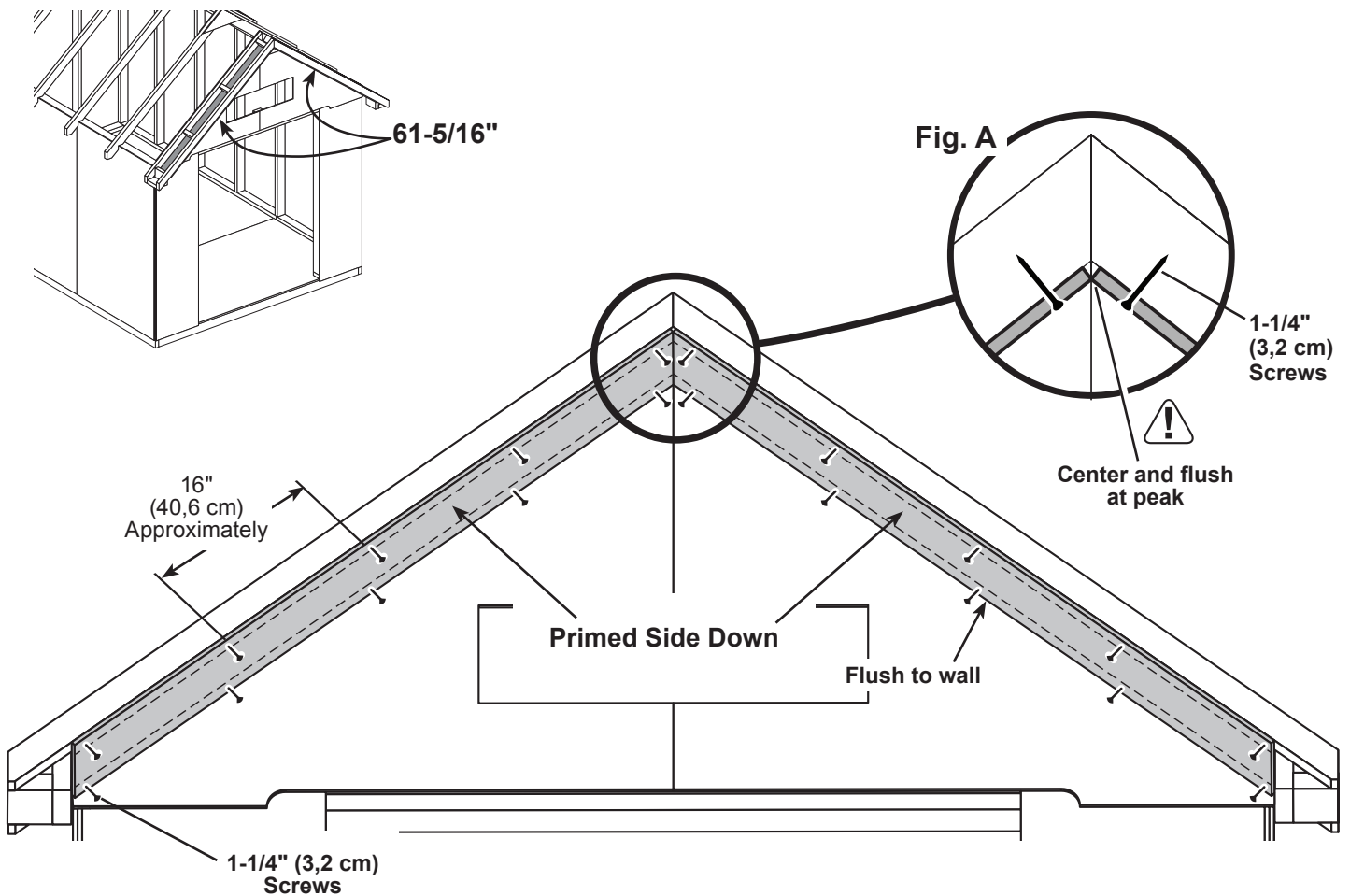

Your gable overhang soffits are installed

SOFFIT NAILERS

PARTS REQUIRED: x2  3/8" x 2" x 5" (1 x 5,1 x 12,7 cm)

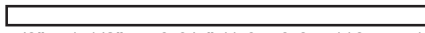
x2  5/8" x 1-1/2" x 46-3/4" (1,6 x 3,8 x 118,7 cm) OSB

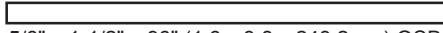
x2  5/8" x 1-1/2" x 96" (1,6 x 3,8 x 243,2 cm) OSB

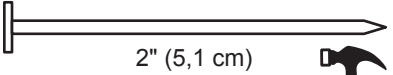
x16  2" (5,1 cm)

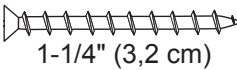
x4  1-1/4" (3,2 cm)



BEGIN

- 1** At the back of the shed, install **2" x 5"** soffit filler flush to bottom and outside edges of rafter (**Fig. A**). Fasten with (2) 1-1/4" screws as shown. Repeat on opposite side.
- 2** Mark wall at each rafter with a square flush to bottom side of rafter and side wall (**Fig. B**).
- 3** Install **46-3/4"** soffit flush to **96"** soffit and marks. Fasten at each mark with 2" nails angled into the studs (nail into studs) (**Fig. C**).

Repeat STEPS 2 - 3 on opposite side.

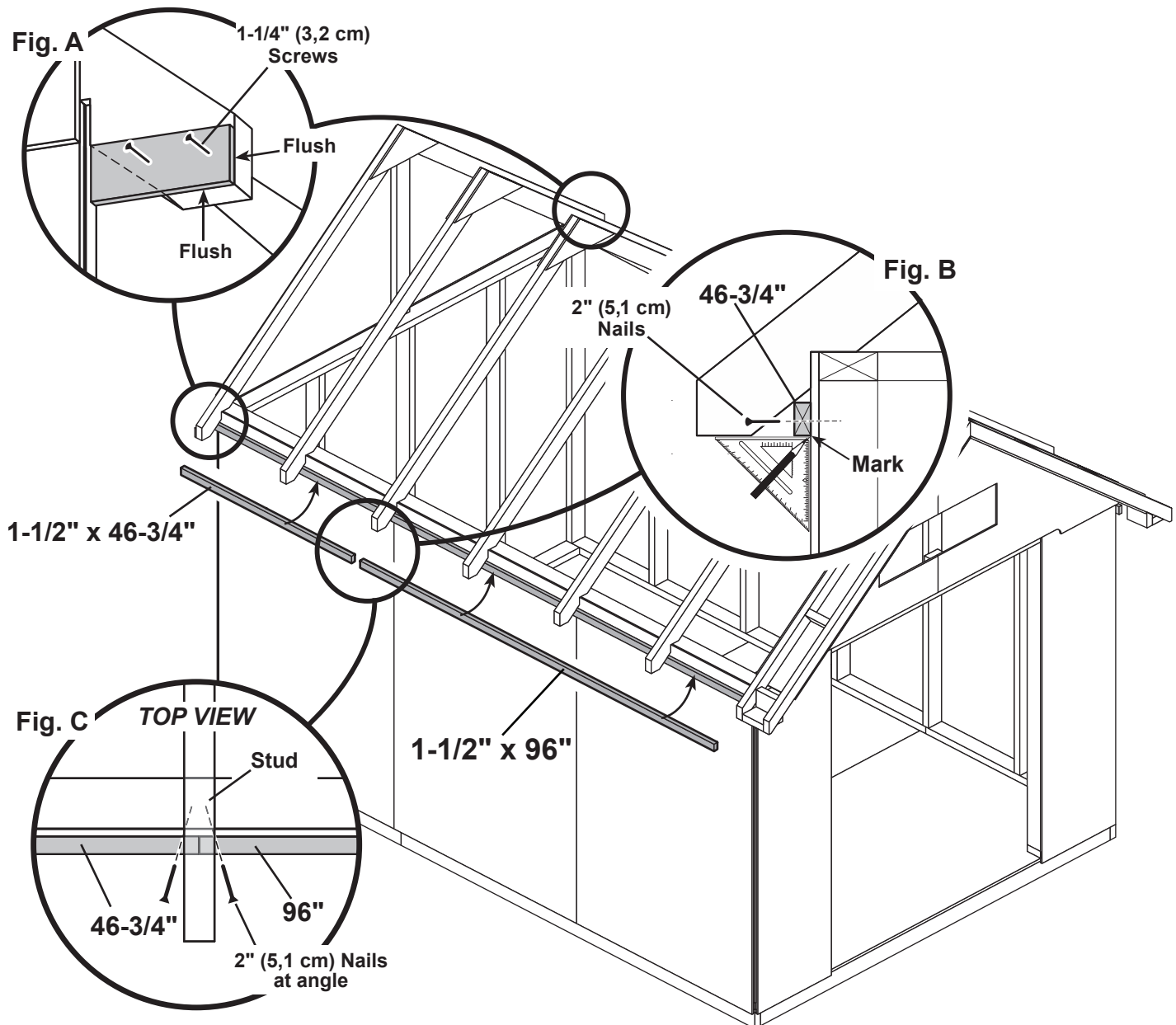

EAVE SOFFIT

PARTS REQUIRED:

x2  3/8 x 5-3/16 x 71-1/4" (1 x 13,2 x 181 cm)

x2  3/8 x 5-3/16 x 79-3/4" (1 x 13,2 x 202,6 cm)

x48  1-1/4" (3,2 cm)



✓ BEGIN

- Place 79-3/4" and 71-1/4" soffit boards primed side down on bottom side of rafter and nailer. Flush soffit board to front corner of overhang L-block (**Fig. A**), side wall panels and nailer (**Fig. B**). Secure with 1-1/4" screws 12" apart and angled into rafter at seam (**Fig. B, Fig. C**).

Repeat steps on opposite side.

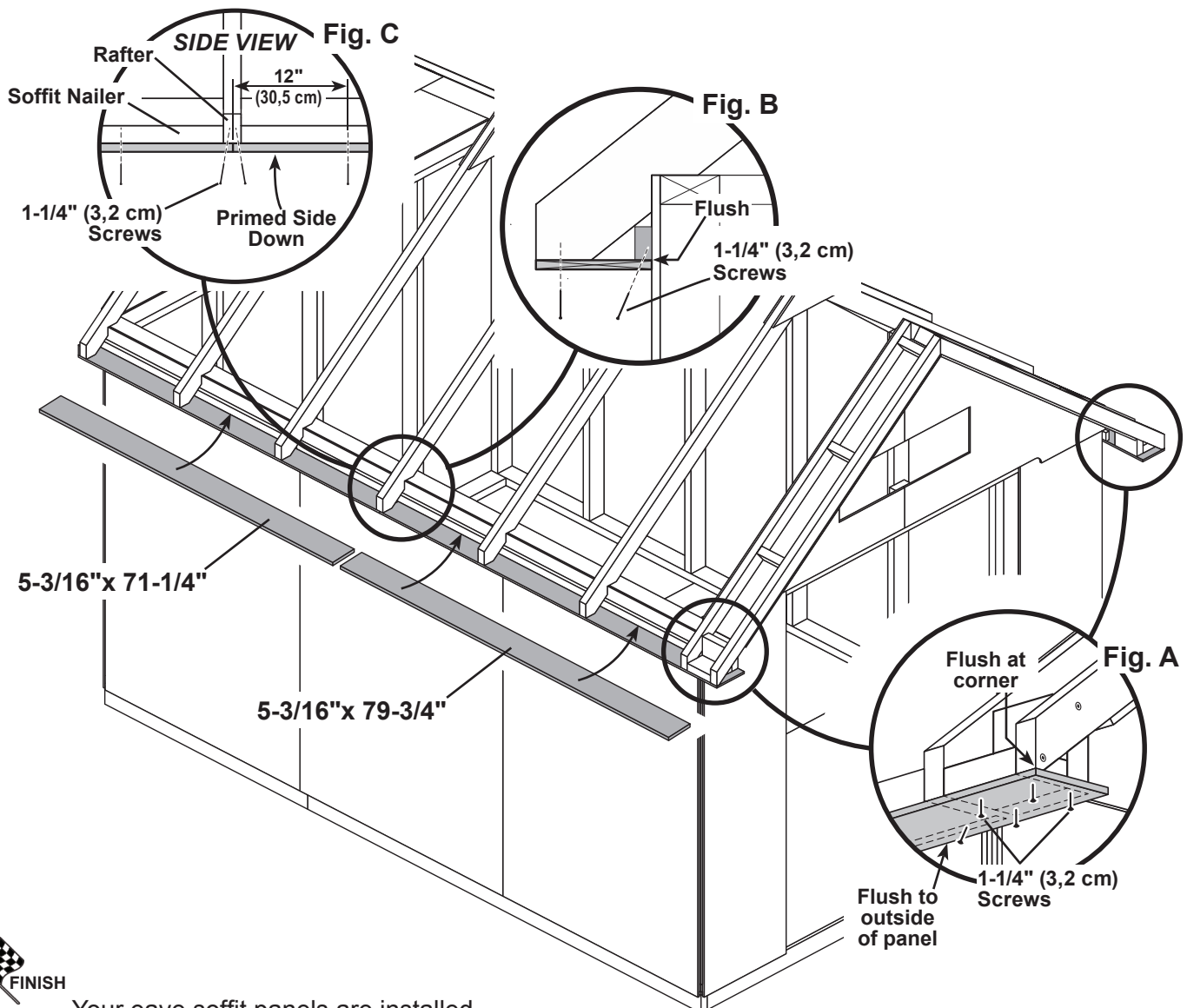

Your eave soffit panels are installed.

ROOF PANELS

PARTS REQUIRED:

x2



7/16 x 21 x 96"
(1,1 x 53,3 x 243,2 cm)

x2



7/16 x 48 x 96"
(1,1 x 121,9 x 243,2 cm)

x2



7/16 x 21 x 23-1/4"
(1,1 x 53,3 x 59,1 cm)

x2



7/16 x 21 x 31-3/4"
(1,1 x 53,3 x 80,6 cm)

x2



7/16 x 48 x 23-1/4"
(1,1 x 121,9 x 59,1 cm)

x2



7/16 x 31-3/4 x 48"
(1,1 x 80,6 x 121,9 cm)

x4

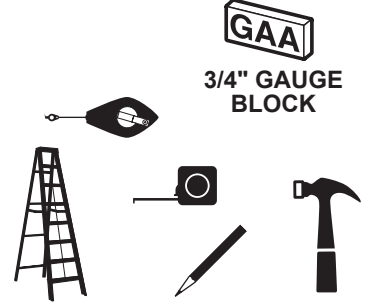
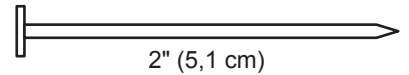

Roof panels may cause serious injury until securely fastened.
Install all roof panels with the rough side facing up (painted grid lines side).



BEGIN

- 1 Attach the 48 x 96" panel with a 3/4" measurement on the rafter (Fig A) and the panel flush at the peak (Fig. B).

Secure panel with (2) 2" nails in the corners.

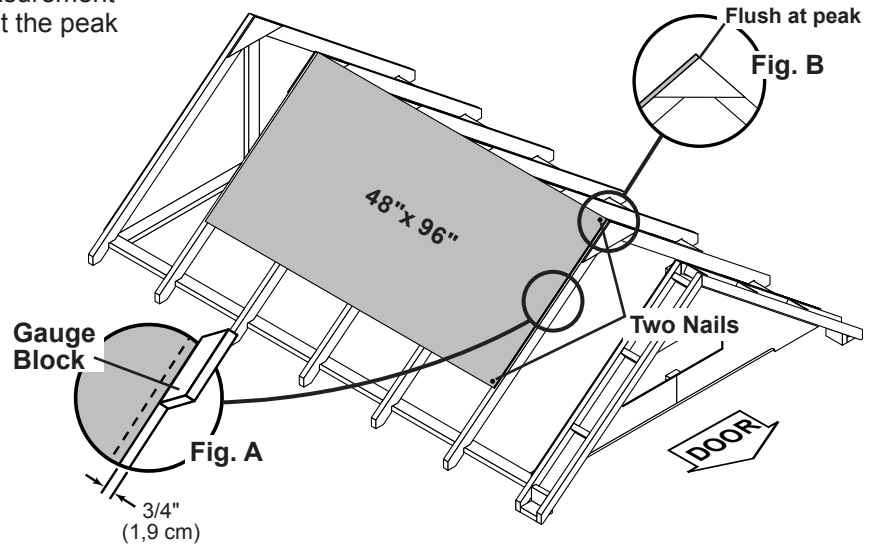

- 2 Move to the opposite end. Using the long edge of the panel as a lever move the panel side-to-side until the top corner is flush to the peak (Fig. B) and with a 3/4" measurement on the rafter (Fig. C).

Secure panel with (2) 2" nails in the corners.

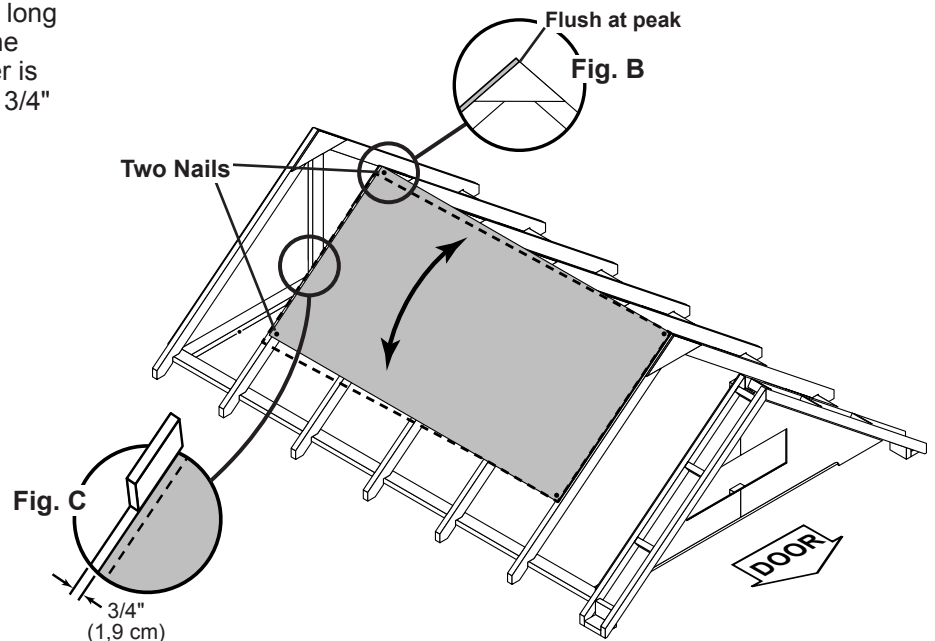

ROOF PANELS

PARTS REQUIRED:

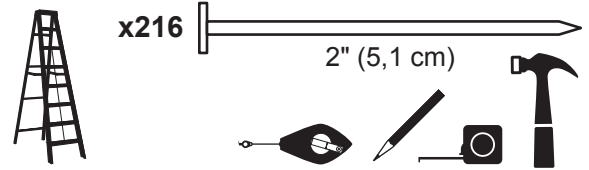

- 3** Keep spacing between the center of the rafters.

Secure with (1) 2" nail into each rafter (Fig. C).

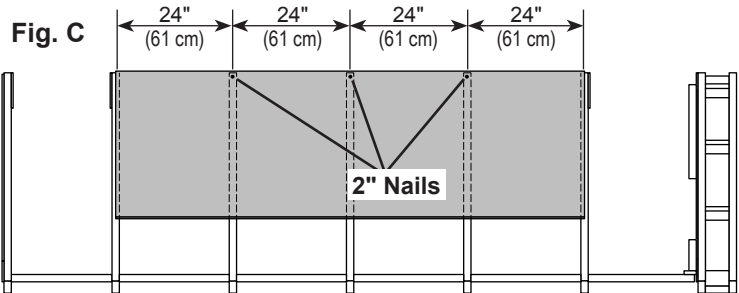

- 4** Install 48"x 23-1/4" and 21"x 31-3/4" roof panels flush to installed panel and flush at rafter peak (Fig. B, Fig. D).

Secure with (2) 2" nails into each panel as shown.

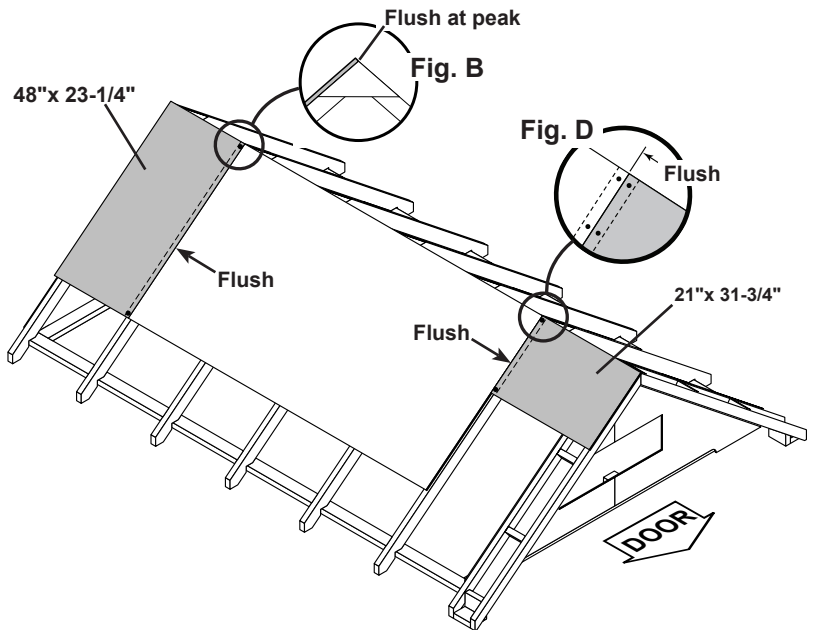

- 5** Push or pull gable unit in or out until roof panel is flush to the outside of gable framing (Fig. E, Fig. F).

Secure with (2) 2" nails into each panel as shown.

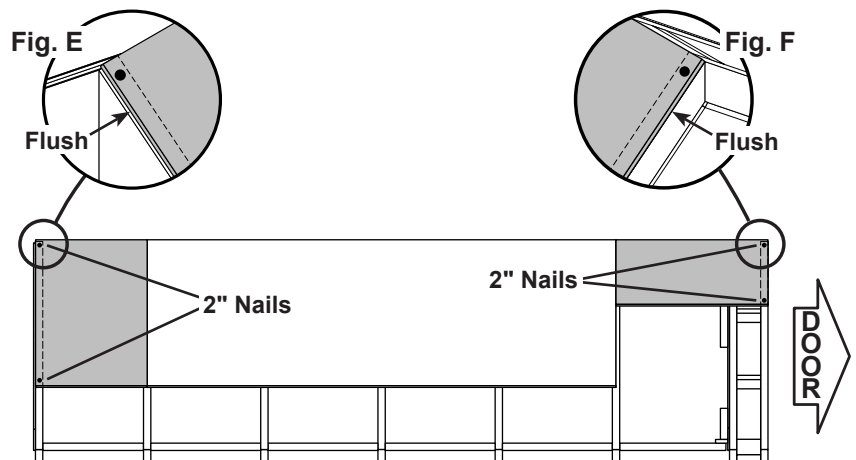

ROOF PANELS

PARTS REQUIRED:

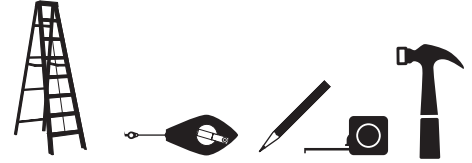

- 6** Install roof panels flush to installed panels and flush to each edge, as shown.

Install panels in the following order:

1. 31-3/4" x 48"
2. 21" x 96"
3. 21" x 23-1/4"

Secure roof panels with 2" nails 6" apart along edges and 12" inside panels.

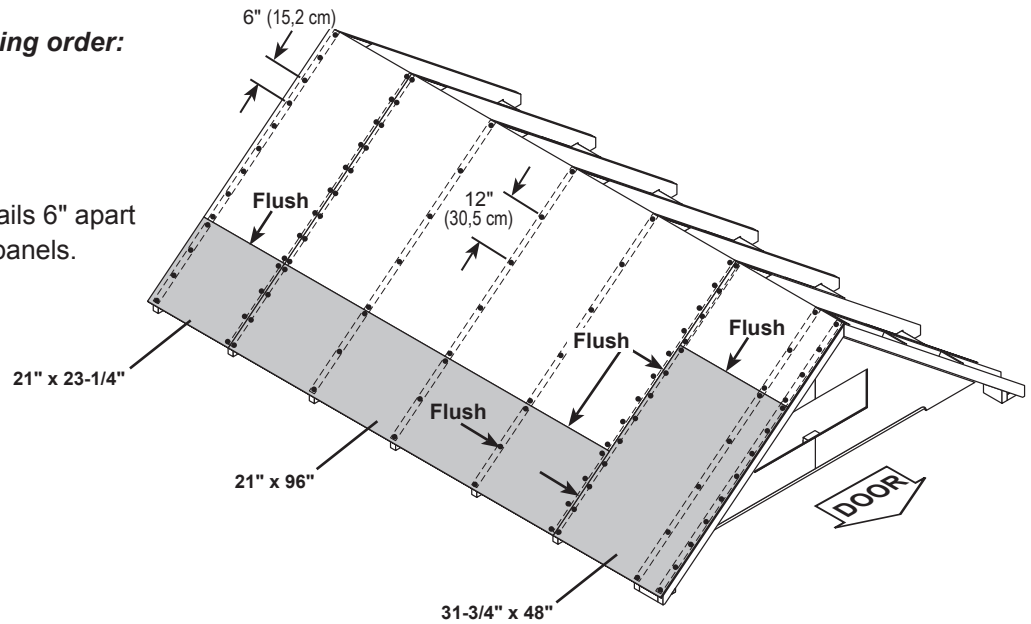

- 7** Repeat process to attach roof panels on the opposite side.

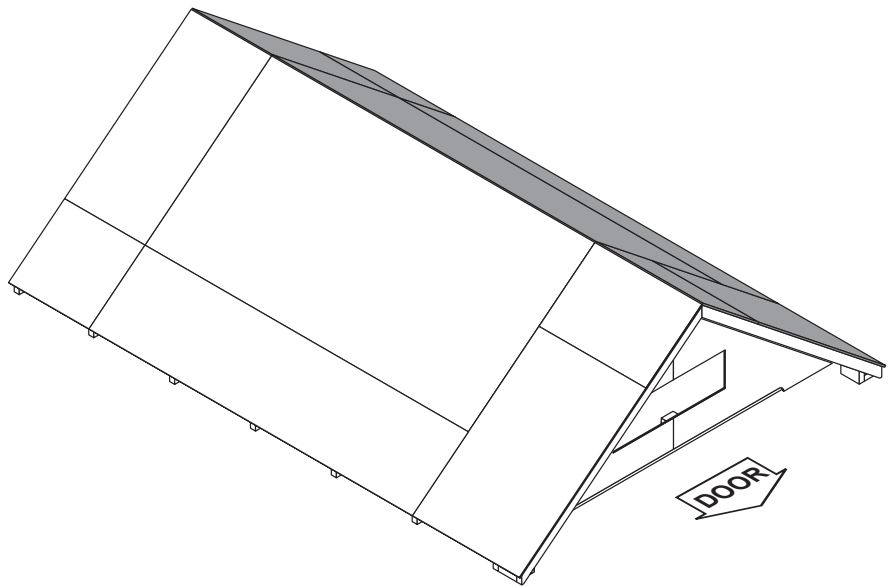

Your roof panels are now installed.

GABLE FASCIA - FRONT

PARTS REQUIRED:

x4 **TEMPORARY GI**
 19/32 x 3 x 23" (1,5 x 7,6 x 58,4 cm)

x2 **PDB**
 19/32 x 3-1/2 x 66-1/4" (2,5 x 8,9 x 168,3 cm)

x1 19/32 x 5-1/2 x 6-13/16"
 (1,5 x 14 x 17,3 cm) LEFT

x1 19/32 x 5-1/2 x 6-13/16"
 (1,5 x 14 x 17,3 cm) RIGHT

x22 2" (5,1 cm)

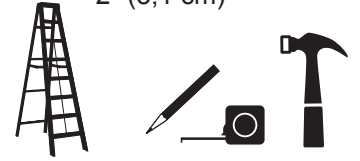

✓ **BEGIN**

Use GI as temporary ledger-boards to help install trim boards.

- 1 Install (4) **GI** projecting out past edge of OSB roof panels, two on each side of roof, as shown. Fasten each with 2" finish nails. **Do not sink nails completely.**

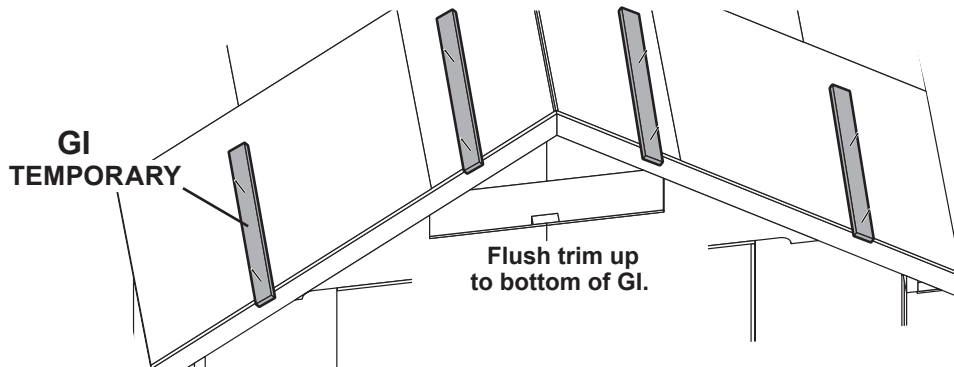

- 2 Install (2) **PDB** primed side facing out, flush at rafter peak and flush to top of OSB roof panels. Fasten trim with 2" finish nails in pattern shown.

- 3 Install soffit caps (5-1/2" x 6-13/16") with primed side facing out and flush to **PDB** gable trim. Fasten soffit caps with (3) 2" finish nails.

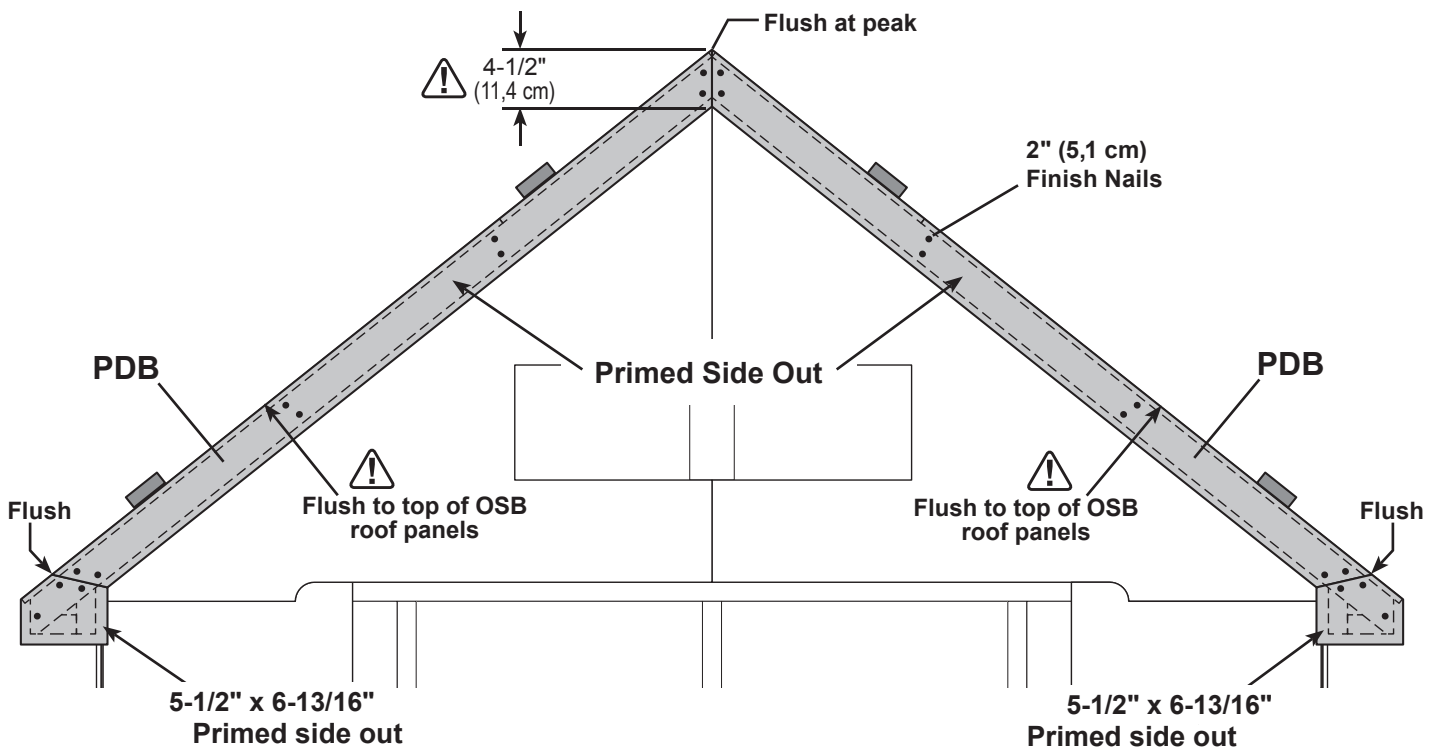

FINISH

Remove temporary roof ledger boards.

Your front gable trim is installed.

FRONT OVERHANG TRIM

PARTS REQUIRED:

x2  3/8 x 4-3/8 x 8-1/2" (1,0 x 11,1 x 21,6 cm)

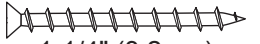
x8  1-1/4" (3,2 cm)



✓ **BEGIN**

- 1 Install overhang corner soffit trim boards primed side out as shown (Fig. A).
Secure parts with 1-1/4" screws.

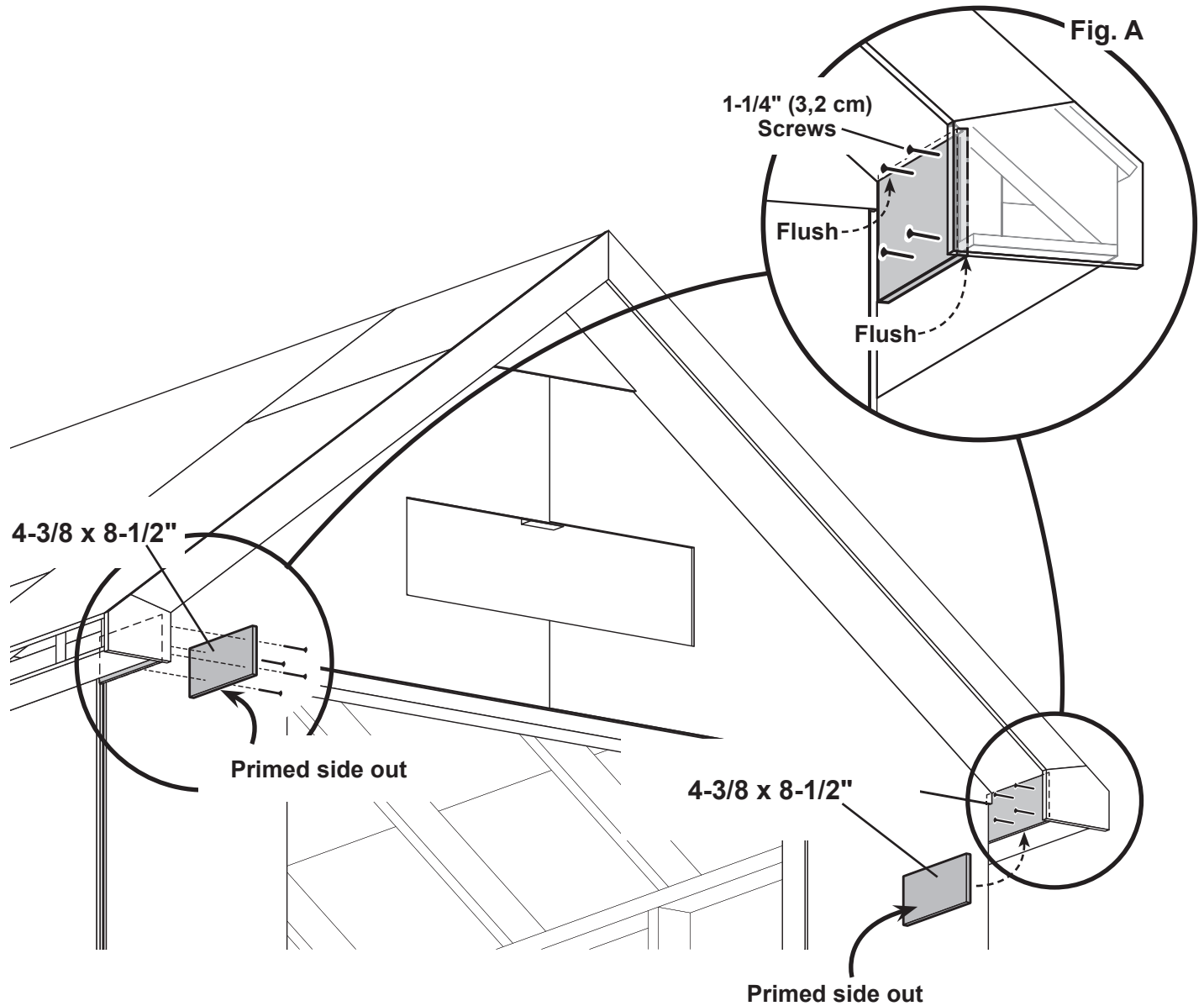

Your corner soffit trim is now installed.

EAVE FASCIA

PARTS REQUIRED:

x2 
3/8 x 3-1/4 x 71-1/4" (1 x 8,3 x 181 cm)

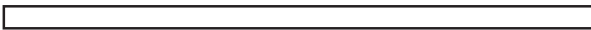
x2 
3/8 x 3-1/4 x 79-3/4" (1 x 8,3 x 202,6 cm)

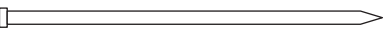
x36  2" (5,1 cm)



✓ **BEGIN**

1 Install eave fascia boards flush to rafters and flush to roof panels (**Fig. A**).

Secure with (2) 2" finish nails at each rafter and (4) 2" finish nails at seam.

Repeat STEP 1 to install fascia on opposite side.

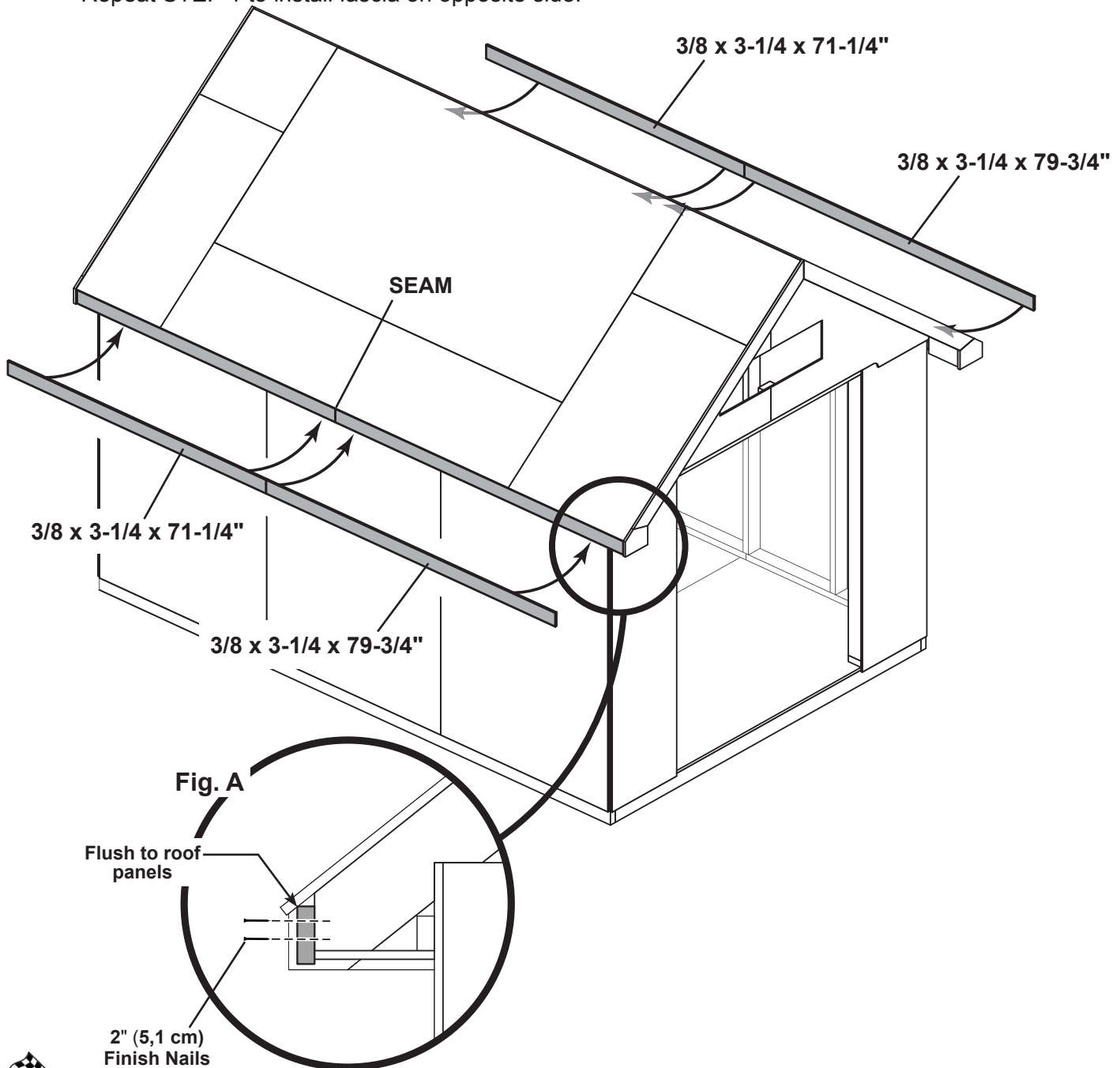

You have installed your eave fascia.

GABLE FASCIA - REAR

PARTS REQUIRED:

x4 **TEMPORARY GI**
 19/32 x 3 x 23" (1,5 x 7,6 x 58,4 cm)

x2 **PDB**
 19/32 x 3-1/2 x 66-1/4" (2,5 x 8,9 x 168,3 cm)

x1 19/32 x 5-1/2 x 6-13/16"
 (1,5 x 14 x 17,3 cm) LEFT

x1 19/32 x 5-1/2 x 6-13/16"
 (1,5 x 14 x 17,3 cm) RIGHT

x22 2" (5,1 cm)



BEGIN

Use GI as temporary ledger-boards to help install trim boards.

- 1 Install (4) **GI** projecting out past edge of OSB roof panels, two on each side of roof, as shown. Fasten each with 2" finish nails. **Do not sink nails completely.**

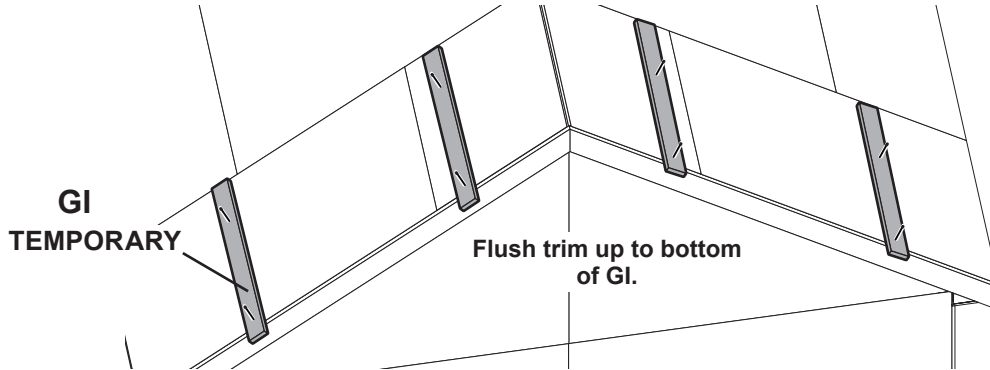

- 2 Install (2) **PDB** primed side facing out, flush at rafter peak and flush to top of OSB roof panels. Fasten trim with 2" finish nails in pattern shown.

- 3 Install soffit caps (5-1/2" x 6-13/16") with primed side facing out and flush to gable trim. Fasten soffit caps with (3) 2" finish nails.

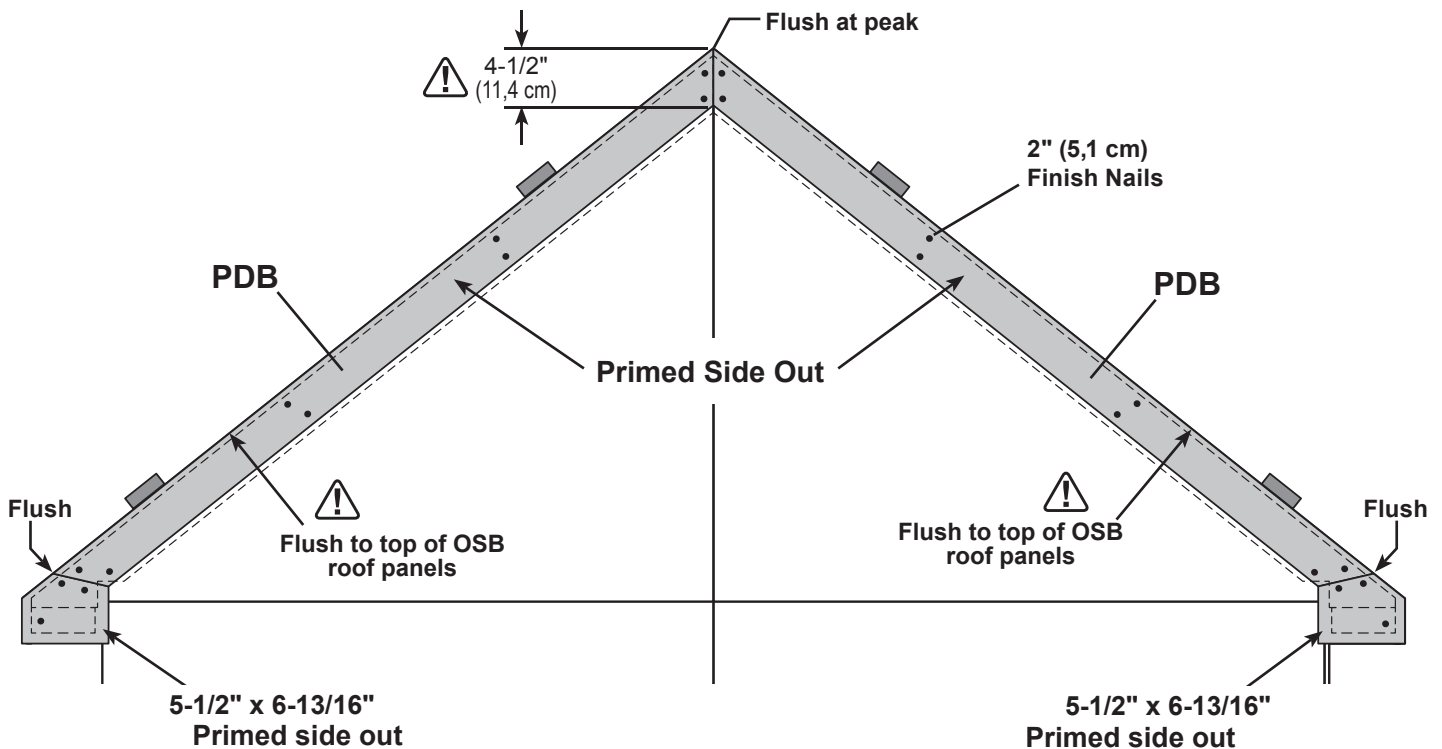

Remove temporary roof ledger boards.

FINISH

Your rear gable trim is installed.

COLLAR TIES

PARTS REQUIRED:

x2 **OP**
2 x 4 x 46-1/2" (5,1 x 10,2 x 118,1 cm)



x12

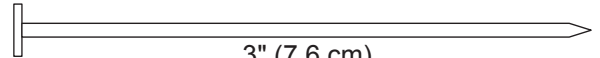

3" (7,6 cm)



✓ BEGIN

1 Position and level **OP** on 3rd and 5th rafters from back wall. Flush **OP** to roof panels.



HINT: For best appearance install **OP** on rafter facing away from door.

2 Secure with 3" nails as shown.

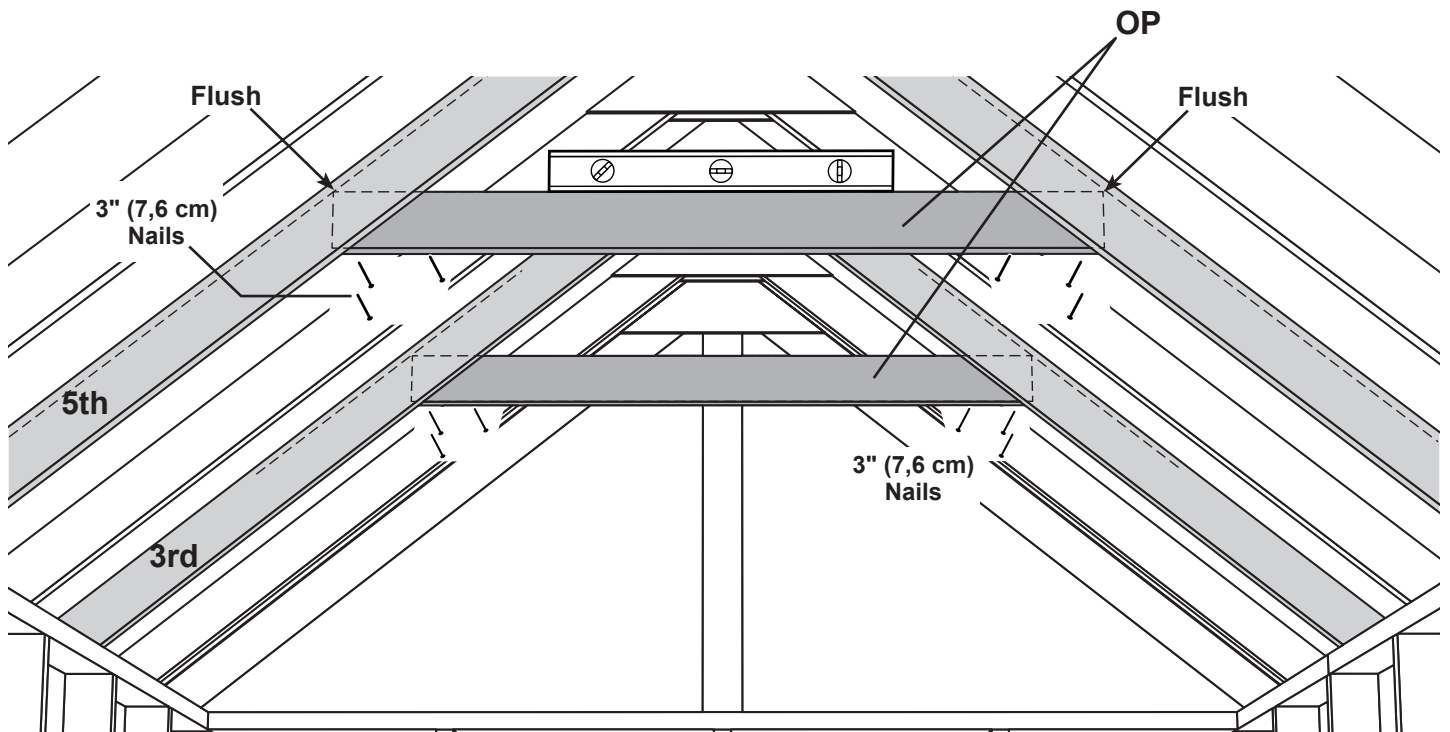

FINISH

Your collar ties are now installed.

DOORS

PARTS REQUIRED:

x1 **OO**
1-1/4 x 2-1/2 x 69" (3,2 x 6,3 x 175,3 cm)

x1 **GAA**
1 x 3 x 5" (2,5 x 7,6 x 12,7 cm)

x4  3" (7,6 cm)

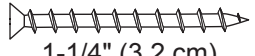
x2  1-1/4" (3,2 cm)

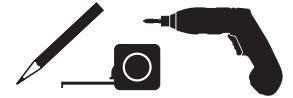
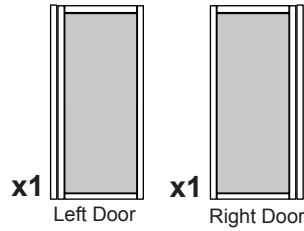

✓ **BEGIN**

1 Orient parts as shown on flat surface. **3/8" offset is to top.**

Look for **red (right)** and **green (left)** on hinge board.

Attach temporary supports **OO** and **GAA** as shown. Tighten securely.

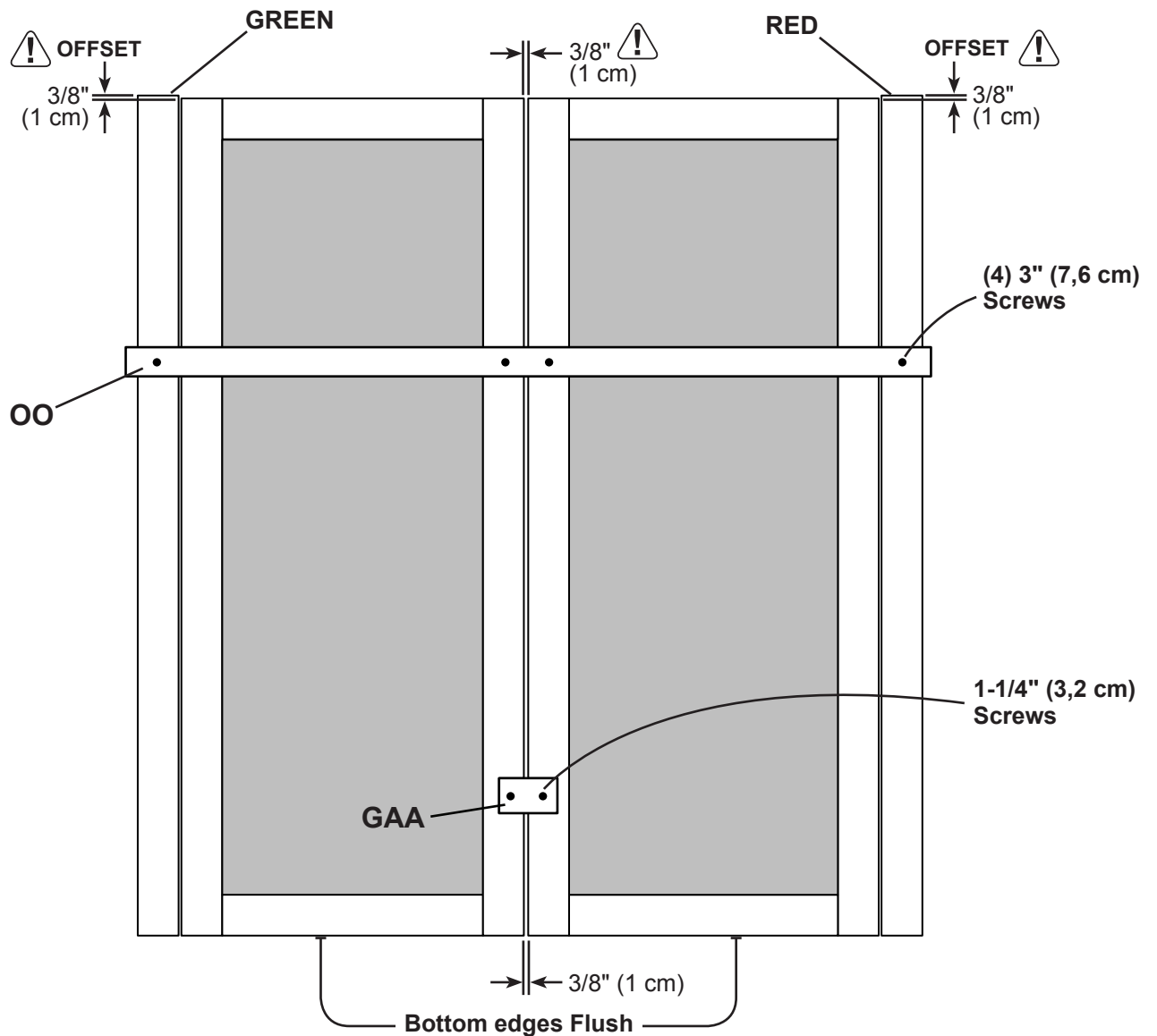

DOORS

PARTS REQUIRED:

x1 
 1-1/4 x 2-1/2 x 69" (3,2 x 6,3 x 175,3 cm)

x12 
 3" (7,6 cm)



- 2 Install **OO** flush under panels.
 Secure to floor frame with (2) 3" screws (**Fig. A**).

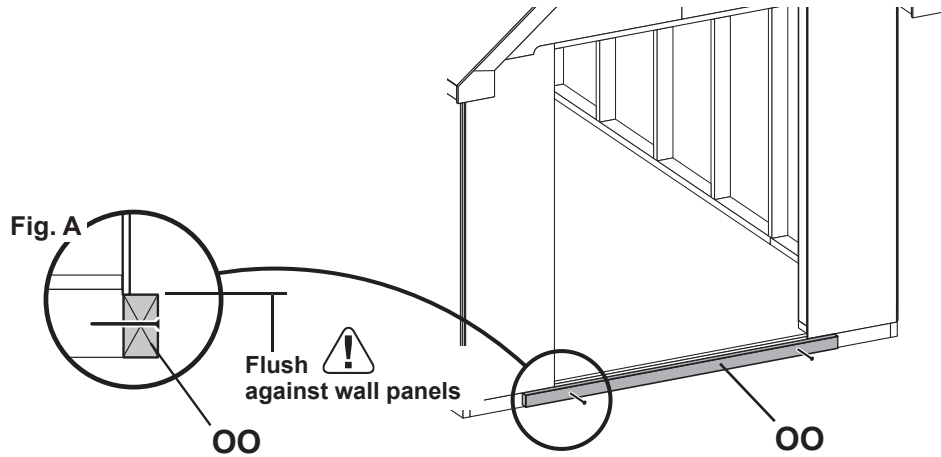

- 3 Center doors on panel seam as shown (**Fig. B**). 

- 4 Screw hinge boards into wall supports and floor with (10) 3" screws as shown.
  **Make sure screws go into framing and floor (Fig. C).**

Remove temporary supports and ensure that the doors open properly.

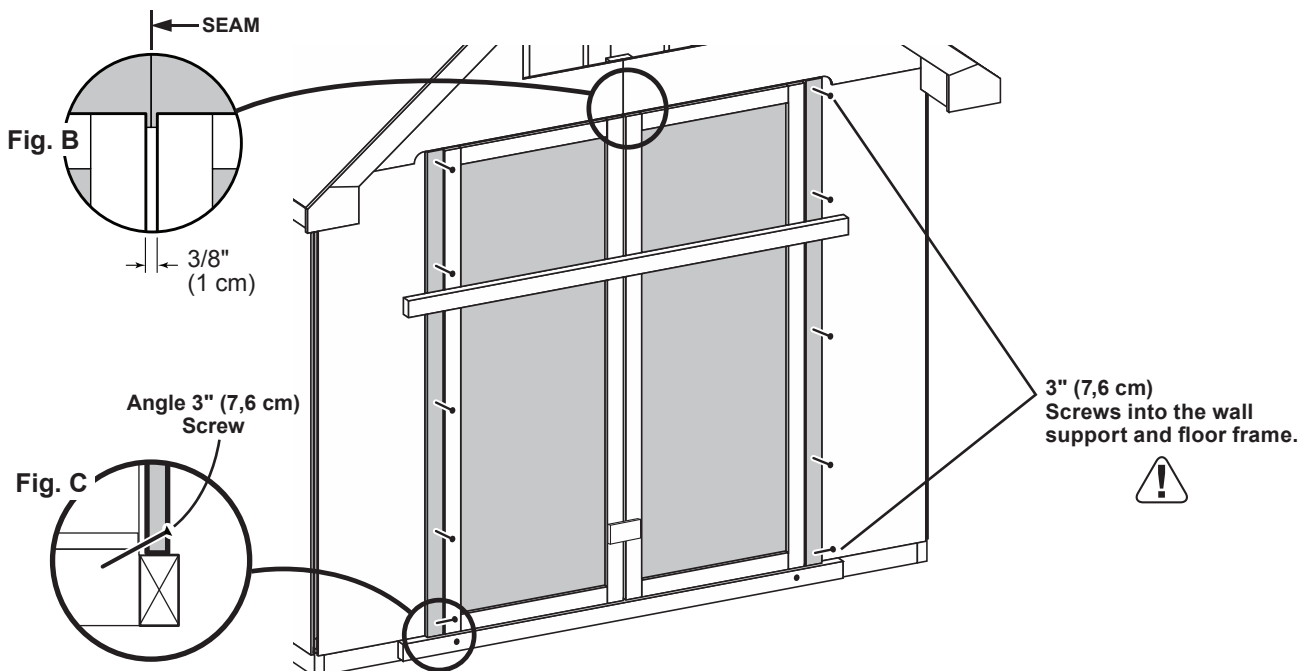

You have finished installing your doors.

DOOR TRIM

PARTS REQUIRED:

x1 **WR**
19/32 x 2-1/2" x 63" (1,5 x 6,4 x 160 cm)

x4 **FA**
19/32 x 2-1/2" x 22-5/8" (1,5 x 6,4 x 57,5 cm)

x1 **56" Metal Threshold**

3/4" (1,9 cm) x11
Bagged separately / special coating

x5 **2" (5,1 cm)** Finish Nails

x56 **3/4" (1,9 cm)** Screws



BEGIN

1 Reinforce the door and install horizontal door rails **FA**.
Secure trim with 3/4" screws from behind door panel into trim (**Fig. A, B**).

2 Center trim **WR** over doors and secure with (5) 2" finish nails.

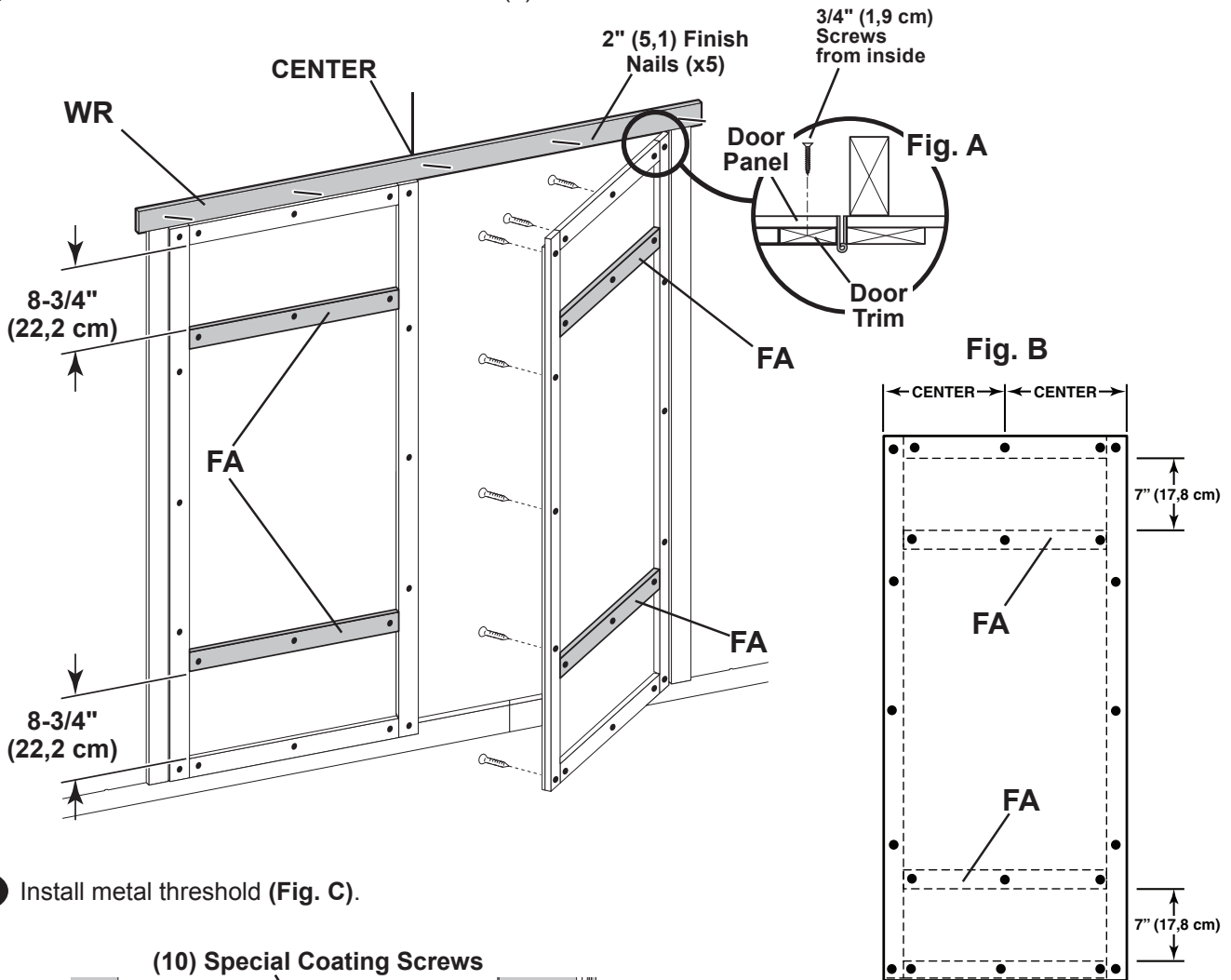

3 Install metal threshold (**Fig. C**).

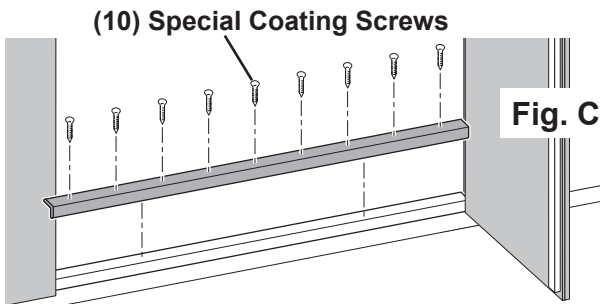

Your door trim and threshold are now installed.

DOOR STIFFENERS

PARTS REQUIRED:

x2 **OO**
1-1/4 x 2-1/2 x 69" (3,2 x 6,3 x 175,3 cm)

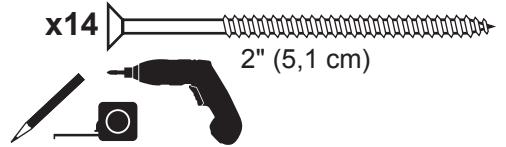

✓ BEGIN

- 1 Center **OO**'s vertically on the left and right doors as shown (Fig. A, Fig. B).
Secure using (7) 2" screws through outside trim into **OO** (Fig. B).

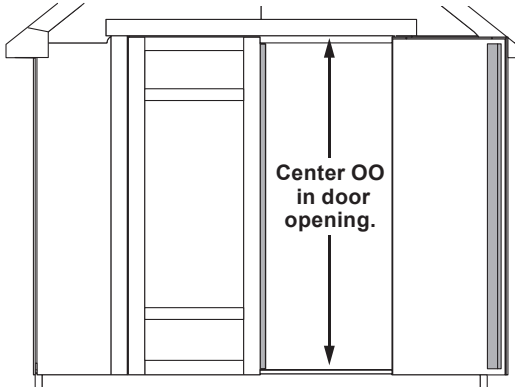
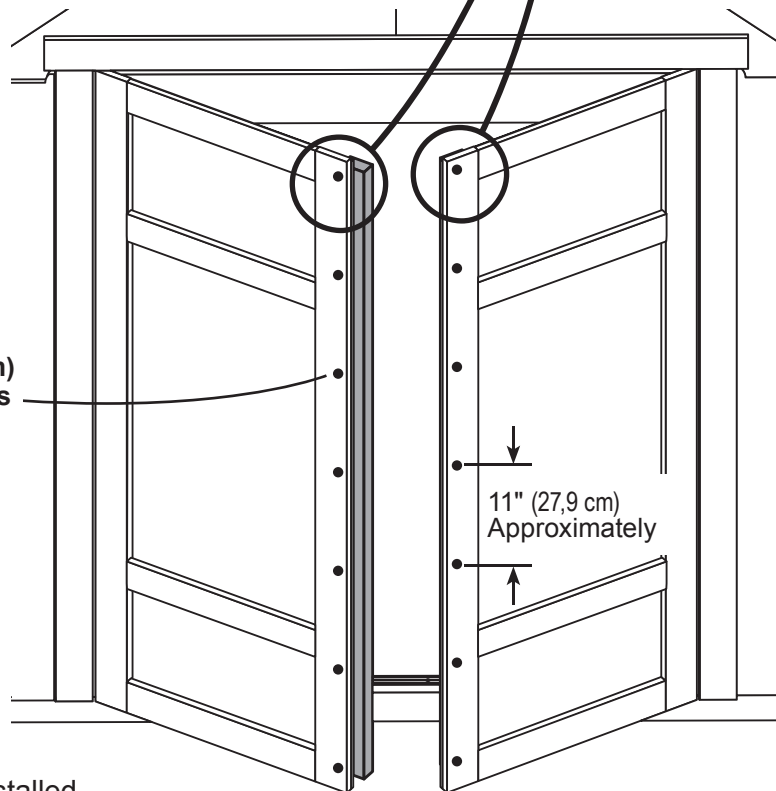
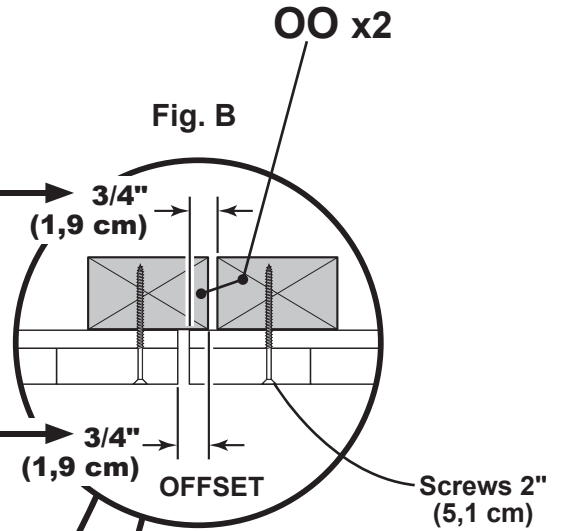
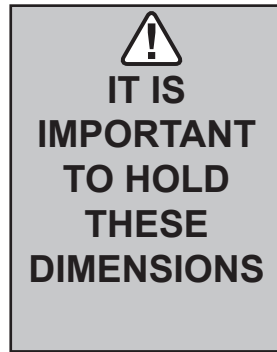

Fig. A



Your door stiffeners are now installed.

DOOR HARDWARE

PARTS REQUIRED:

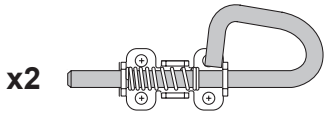

x8 
1" (2,5 cm)



✓ BEGIN

- 1 Place spring bolt onto **OO** in open position with bolt end 3/8" down from frame. Bolt is open when loop is contacting base (**Fig A**).
Mark and pre-drill holes for screws.
- 2 Install bolt with screws supplied and drill 5/16" hole for bolt to extend into.
- 3 Place bolt onto **OO** in open position with bolt end 1/2" up from floor. Bolt is open when loop is contacting base (**Fig B**).
Mark and pre-drill holes for screws.
- 4 Install bolt with screws supplied and drill 5/16" hole for bolt to extend into.

Fig. A

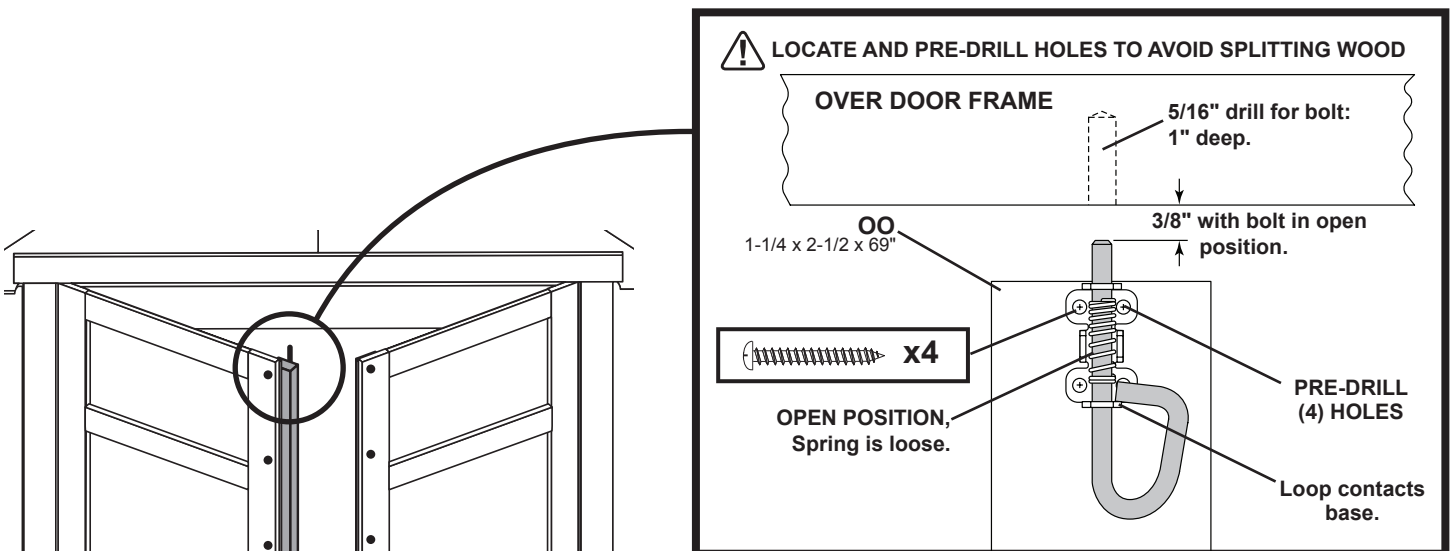
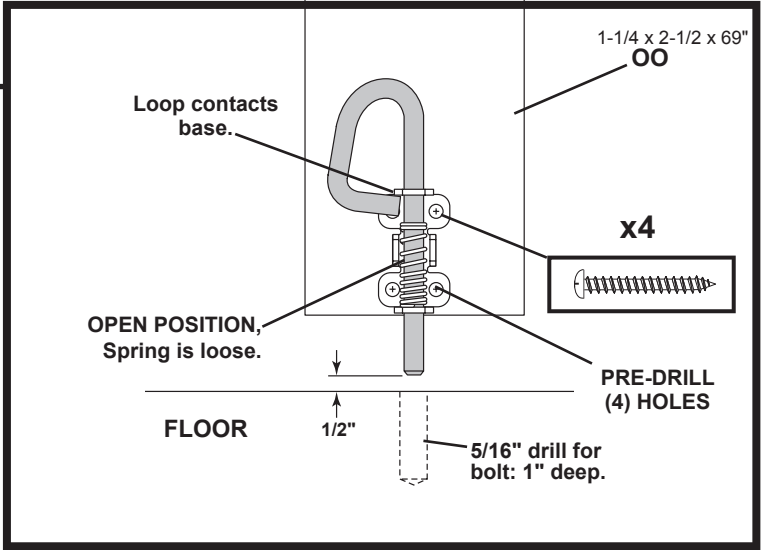

Fig. B



Your spring bolts are now installed.

DOOR HARDWARE / DECORATIVE HINGES

PARTS REQUIRED:

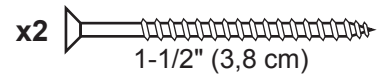
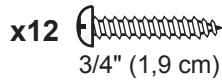
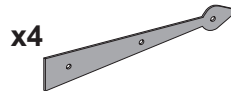
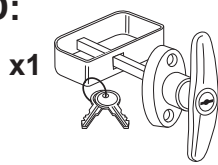

3/8" (10,9 cm) Drill Bit

1/4" (0,6 cm) Drill Bit



✓ BEGIN

- 1 Measure and mark location of hole on outside of right door as shown (Fig. A).
Pre-drill hole with 1/4" drill.

Re-drill hole with 3/8" drill.

- Keep drilled hole square to trim to avoid breaking edge of door stiffener.

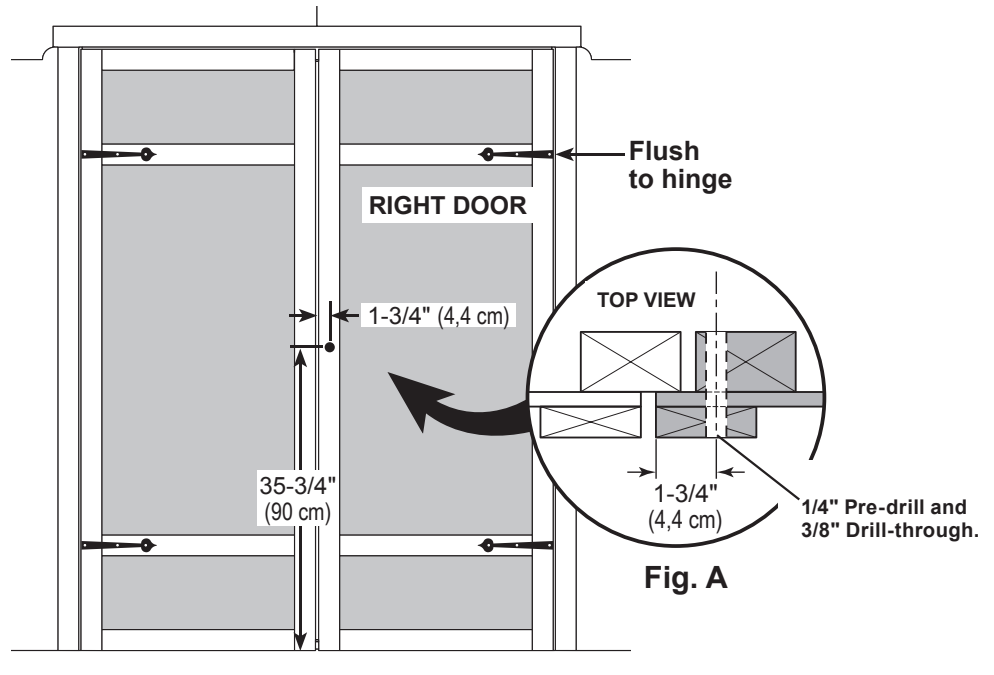

- 2 Insert handle in hole and secure with 1-1/4" screws.
- 3 Attach inside handle and secure with set screw as shown.
- 4 Install decorative hinges on horizontal trim and flush against hinge as shown.

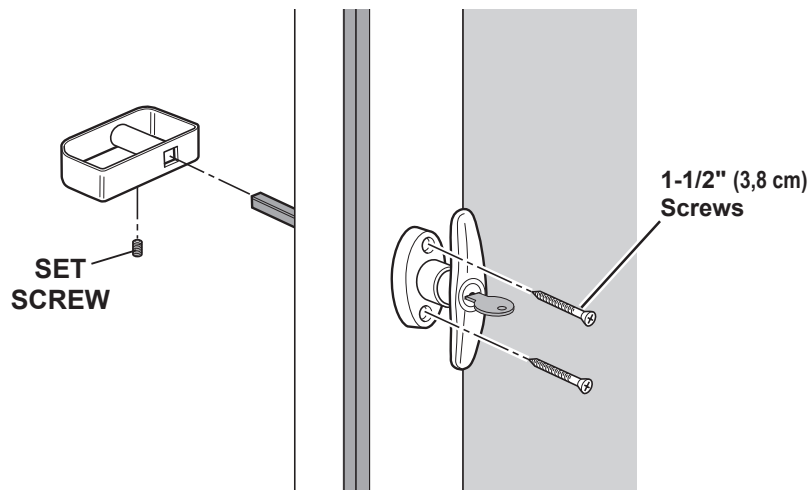

Your T-handle and decorative hinges are now installed.

GABLE PEAK

PARTS REQUIRED:

x1  7-1/4 x 18-1/4" (18,4 x 46,4 cm)
WITH WOOD GRAIN ON FACE

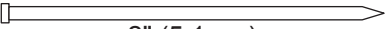
x4  2" (5,1 cm)

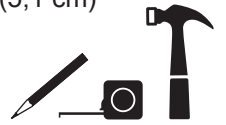

✓ **BEGIN**

- 1 Position gable peak flush to peak of overhang as shown.
Secure using (4) 2" finish nails.

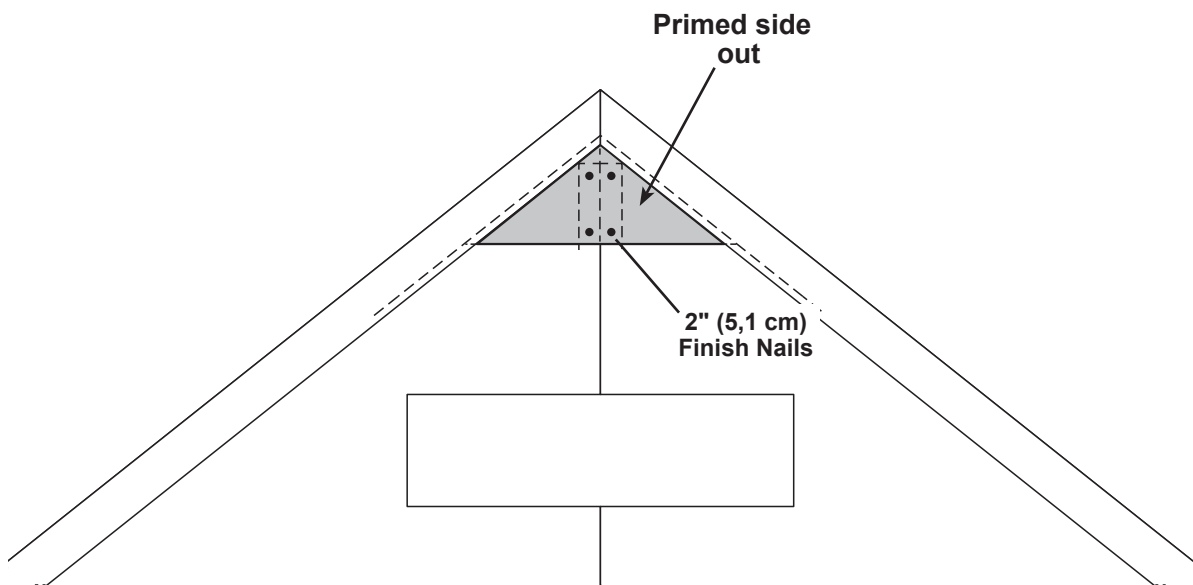

Your front gable peak trim is installed.

GABLE WINDOW

PARTS REQUIRED:

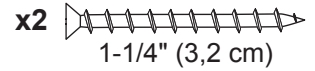
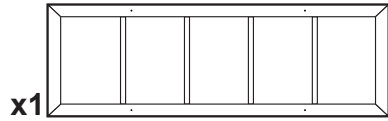



✓ BEGIN

1 Apply high quality exterior-grade caulk behind frame near edge before installing to seal window.

2 From outside of shed, position window in opening and level.
Use (2) screws at top of windows.

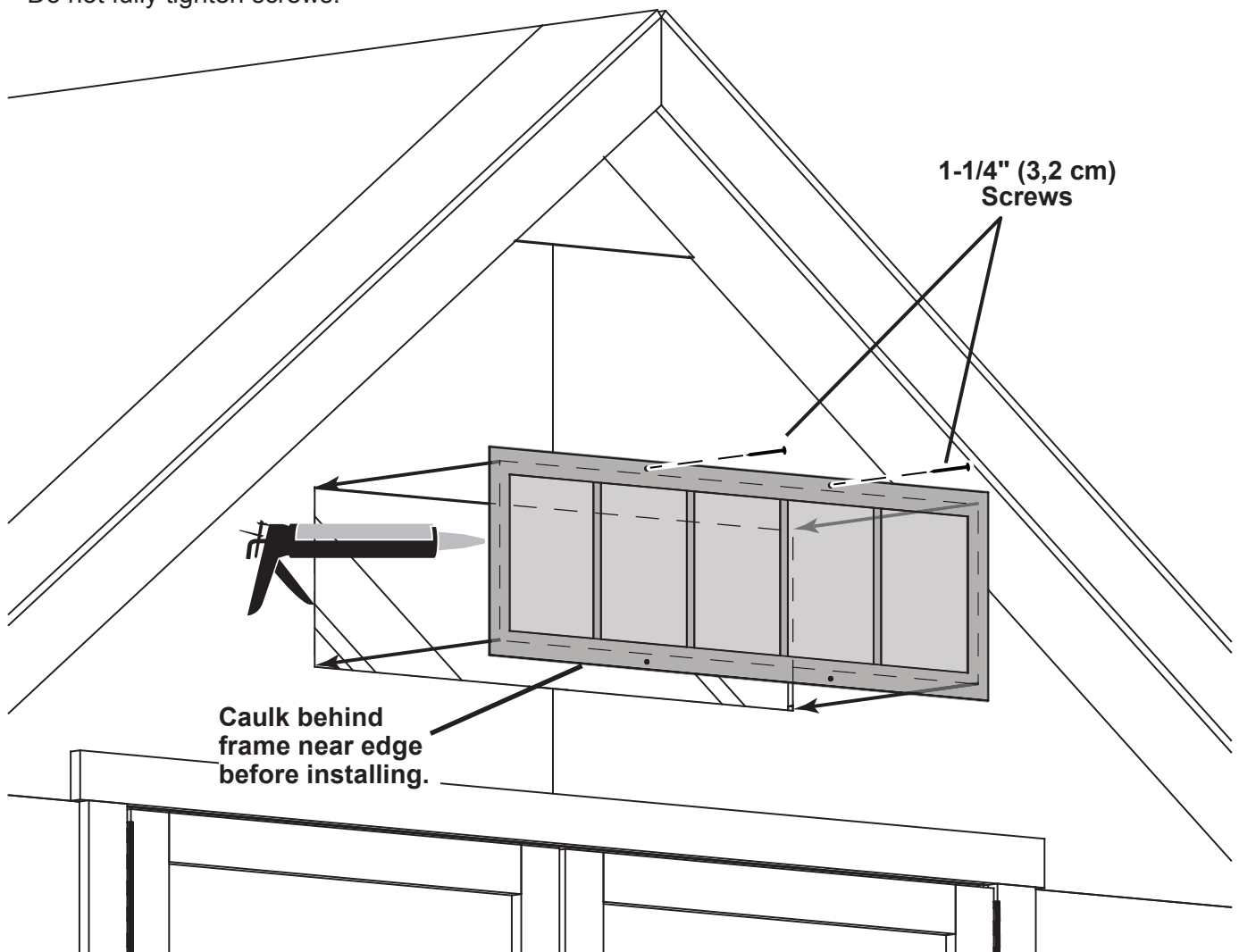
Do not fully tighten screws.



 **You must use a caulk sealant behind window flange in order to validate your warranty.**

WINDOWS

PARTS REQUIRED:

x2 **WA**

19/32 x 2-1/2 x 36-3/4" (1,5 x 6,4 x 93,3 cm)

x2 **EY**

19/32 x 2-1/2 x 9" (1,5 x 6,4 x 22,9 cm)

x8

2" (5,1 cm)



3 Center **WA** 3/4" onto window frame. Secure using (2) 2" finish nails as shown.

 Do not nail into window flange.

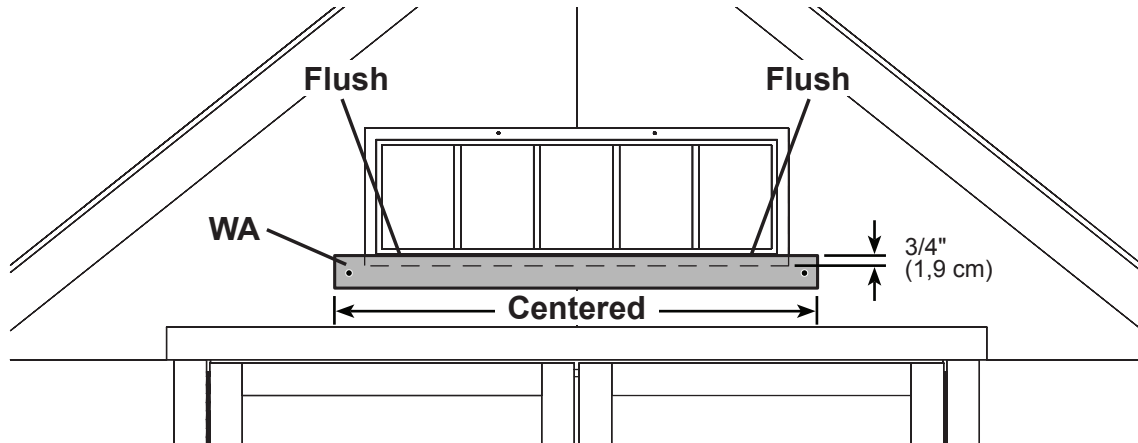

4 Position **EY** on onto window frame as shown. Secure using (2) 2" finish nails.

Remove 1-1/4" screws.

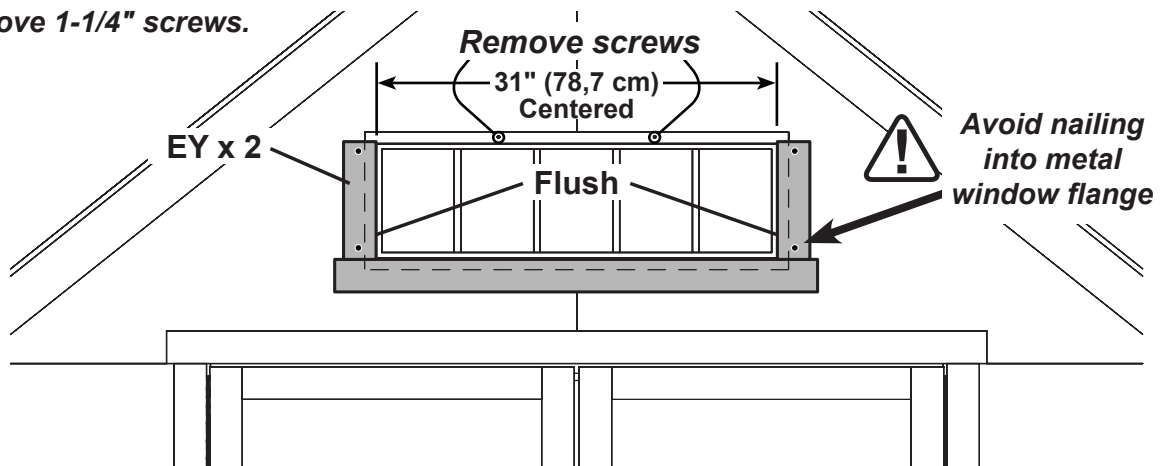

5 Position **WA** centered onto window frame as shown. Secure using (2) 2" finish nails.

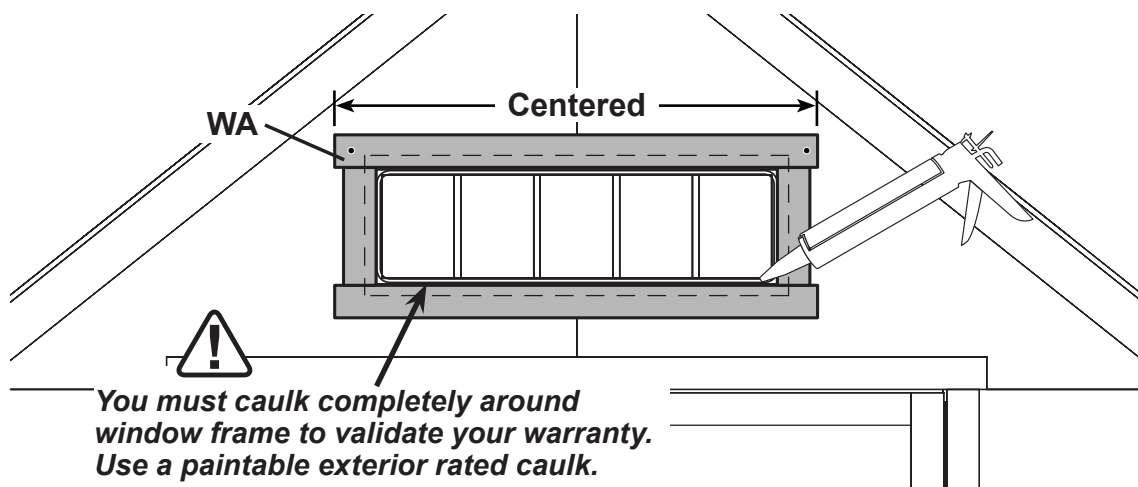

GABLE WINDOW

PARTS REQUIRED:



x12 
3/4" (1,9 cm)

- 6 From inside, secure trim with (12) 3/4" screws.

Snip protruding finish nails.

 Do not screw into window flange.

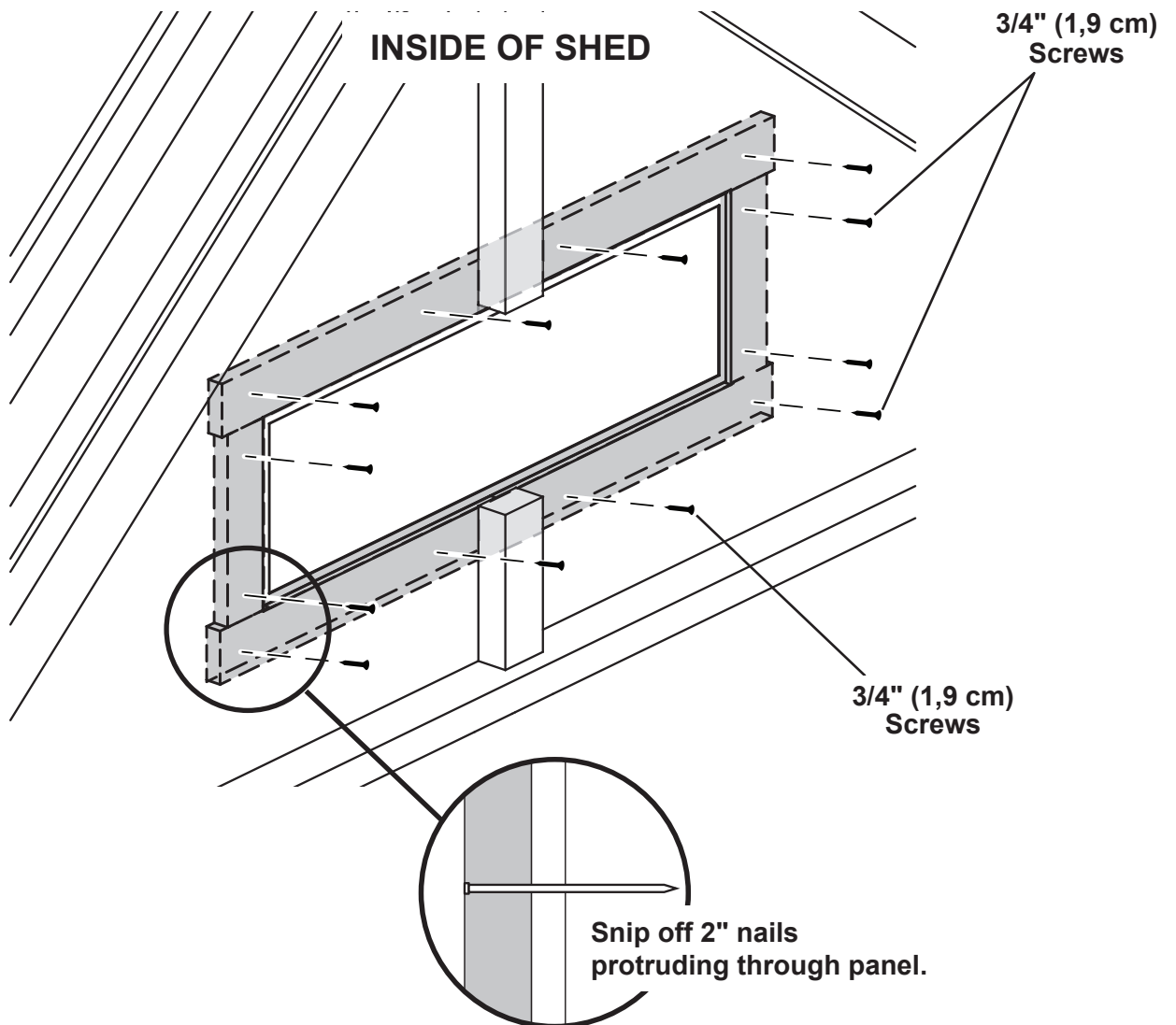

Your window is now installed.

CORNER TRIM

PARTS REQUIRED:

x4 
 3/8 x 1-3/4 x 70-1/2" (1 x 4,4 x 179,1 cm)

x4 
 3/8 x 1-3/4 x 67-9/16" (1 x 4,4 x 171,6 cm)

x48  2" (5,1 cm)



✓ BEGIN

- 1** Front and back 70-1/2" corner trim is flush under gable panel and flush along the face of side wall panel. Fasten with 2" finish nails spaced evenly.
- 2** Install 67-9/16" side corner trim flush along edge of front corner trim and flush up against eave soffit. Fasten with 2" finish nails spaced evenly.

Repeat STEPS 1 - 2 to install trim to all four corners.

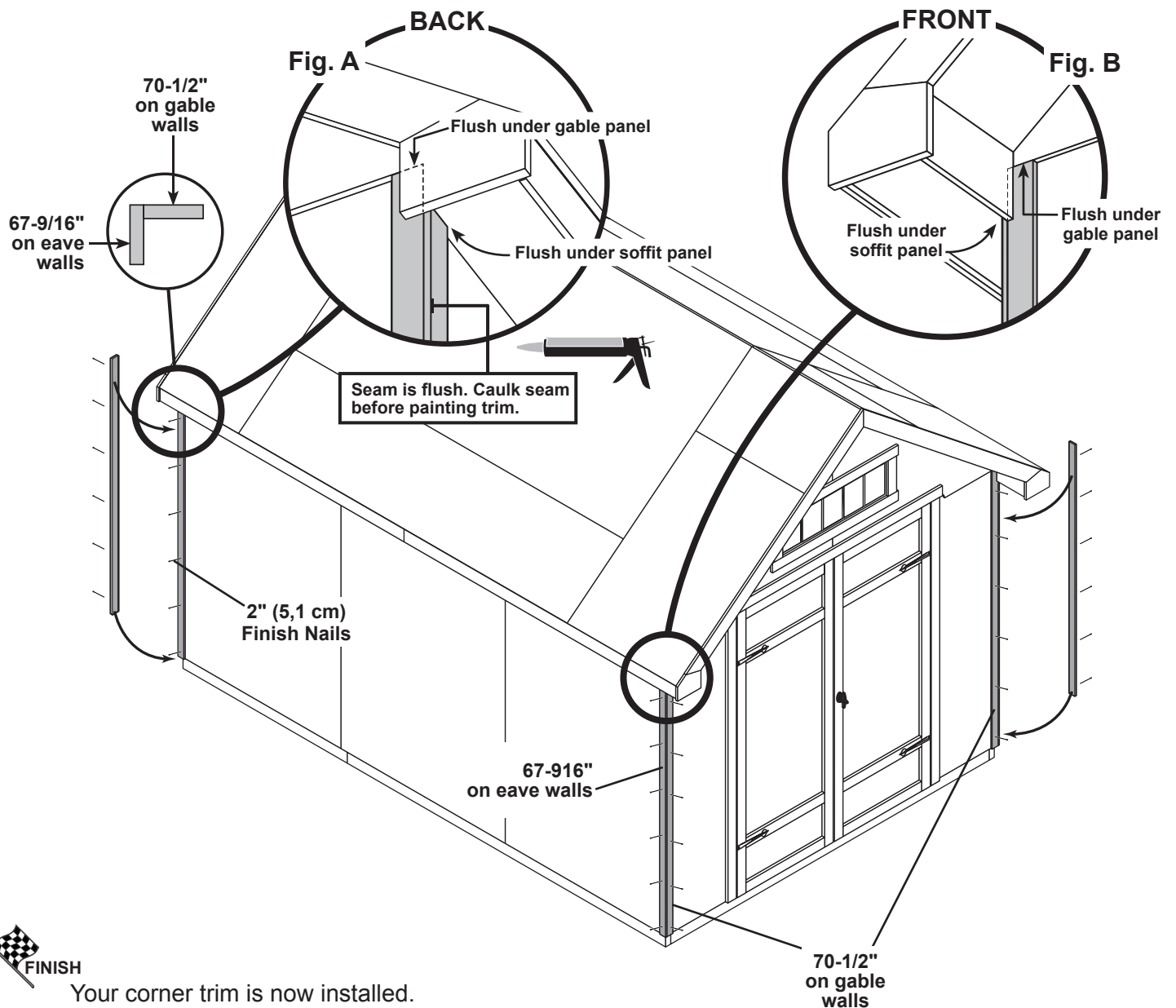

HOOK & EYE

PARTS REQUIRED:

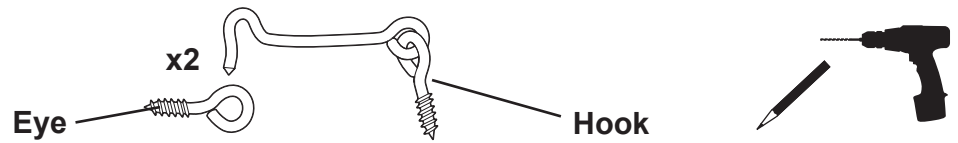

✓ BEGIN

- 1 Install hooks into endcap and into L-block behind (Fig. A).
- 2 Swing door open to locate eye.

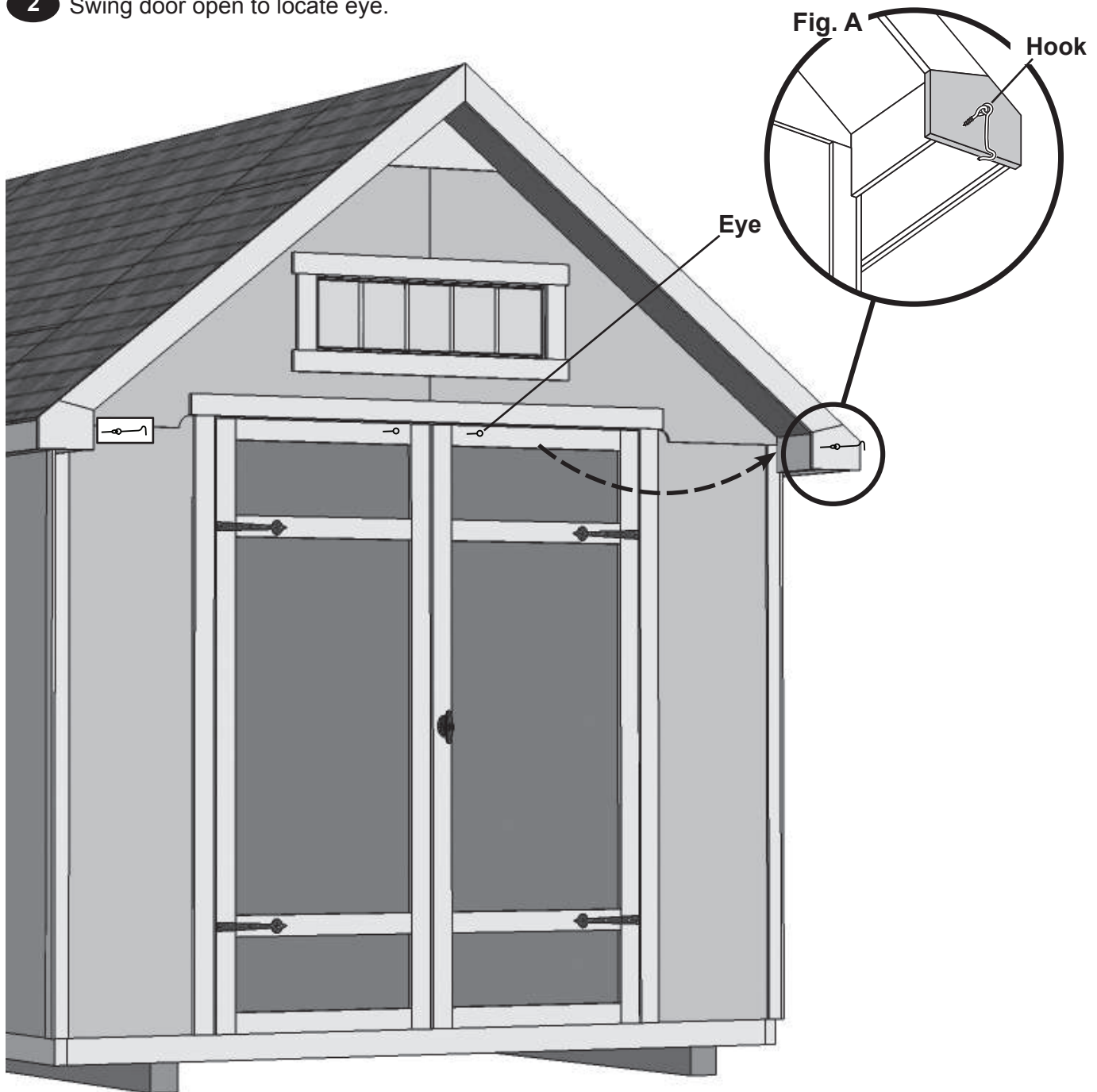

Your hook and eyes are installed.

VENTS

PARTS REQUIRED:

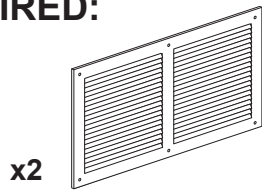

8 x 16"
(20,3 x 35,6 cm)

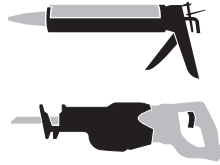

x12
1/2" (1,3 cm)



You can place your side wall vent on either side of shed

✓ **BEGIN**

1 Locate and mark for vents in side walls. Install (1) vent near the floor and (1) vent near the eave.

Caulk behind vent flanges.

Secure with 1/2" screws.

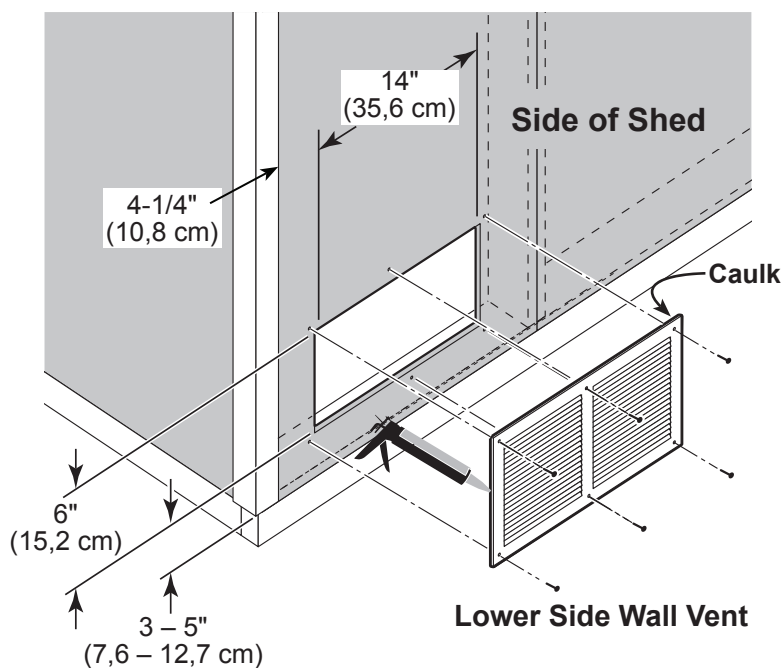
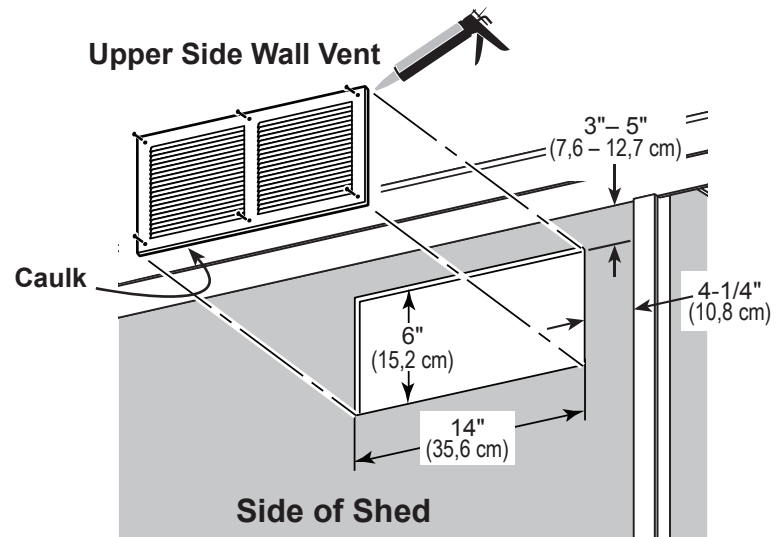

FINISH

Your vents are now installed.

PAINT & CAULK

- NOT INCLUDED -

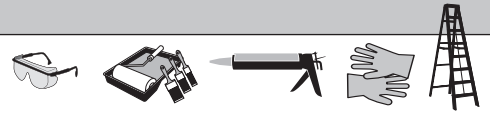

- Use acrylic latex caulk that is paintable. Caulk at all horizontal and vertical seams, between the trim and walls, and all around the door trim.
- Use a high quality exterior acrylic latex paint. When painting your building, there are a few key areas that can be easily overlooked that must be painted:
 - Bottom edge of all siding and trim
 - Inside of doors and all 4 edges

Note:

Prime all un-primed exterior wood before painting.
(Follow directions provided by manufacturer.)

ROOF FELT

- NOT INCLUDED -

- Install felt flush to all roof edges overlapping 3". Use minimal amount of roofing nails to hold in place.

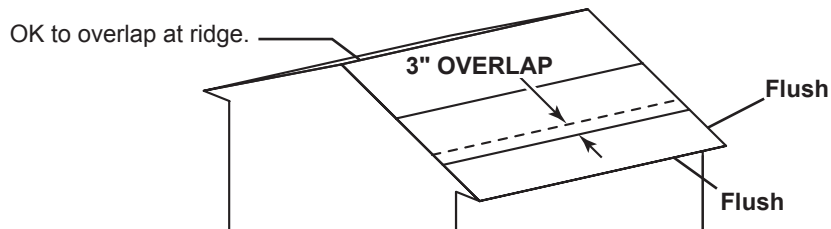

DRIP EDGE

- NOT INCLUDED -



- Install drip edge over roof felt on gable side and under roof felt on eave side (**Fig. A**).
- Do not use nails on side of drip edge that hangs over side of building.
- Only nail top of drip edge as shown.

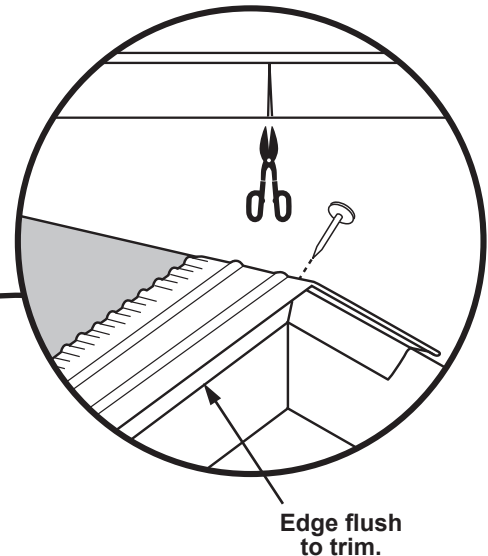
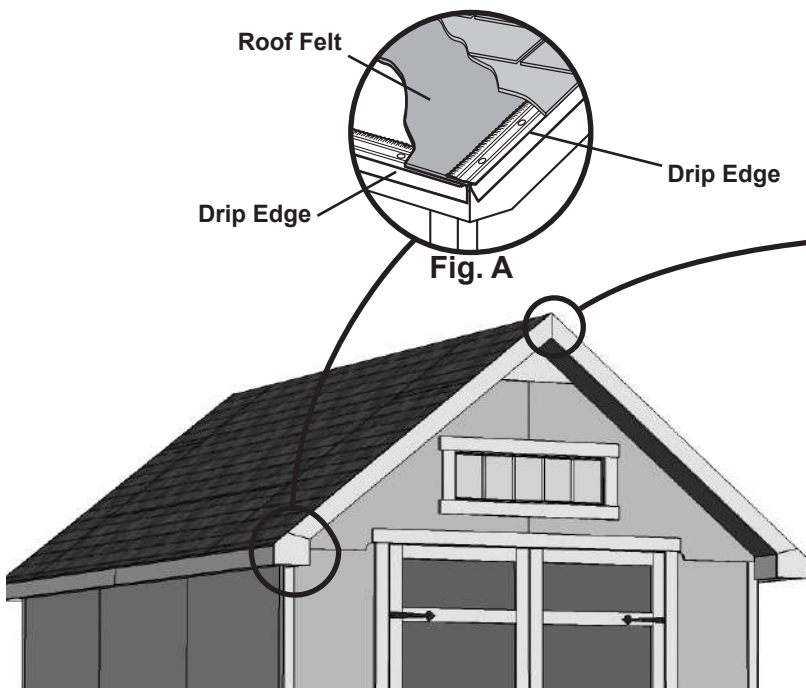

Snip bottom side of drip edge and bend over to other side of roof.

(Follow directions provided by manufacturer.)

SHINGLES

- NOT INCLUDED -

• Follow directions provided by manufacturer and these instructions.

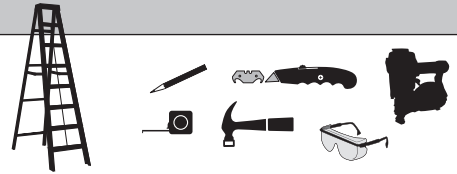

! Familiarize yourself with a 3-Tab Shingle.

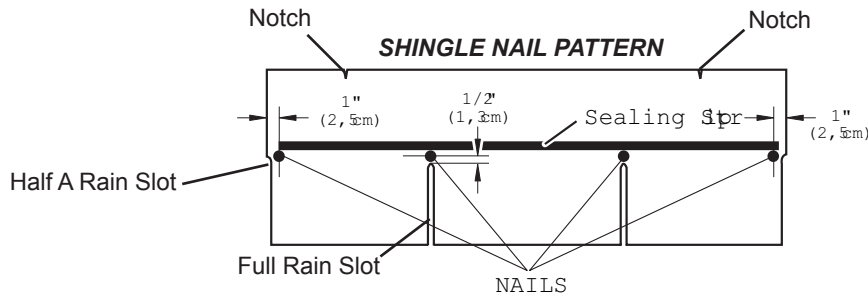

! NEVER DRIVE FASTENERS INTO OR ABOVE SEALING STRIPS.

✓ BEGIN

- 1** Install first starter row upside down and color up with a 1" overhang at back and bottom of roof panel. Use (4) nails per shingle. **Starter row must be straight and level all the way across with lower edge of roof deck.**
NOTE: If you have installed drip edge install shingles flush to drip edge.

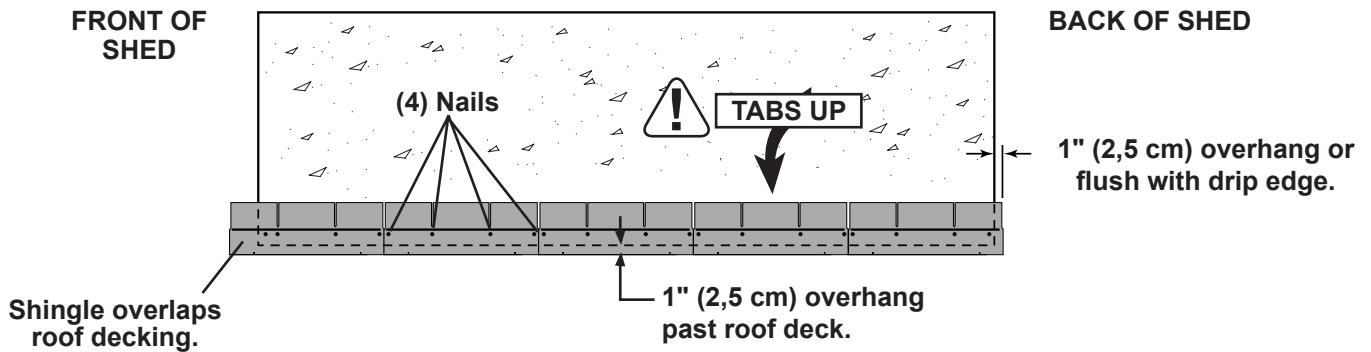

SHINGLES

continued...

- 2 Beginning at front of shed, install first row of shingles with notch at 1" past roof edge or flush with drip edge.

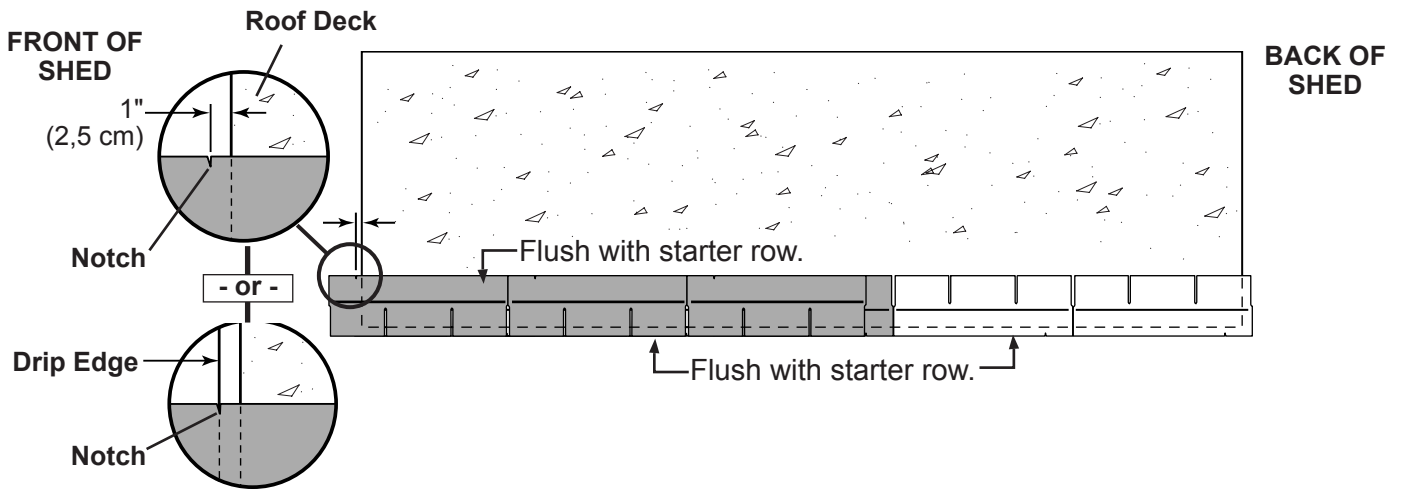

- 3 Install second row of shingles flush at top of first row's rain slots. Ensure 1" overhang or flush to drip edge at front, stagger each row.

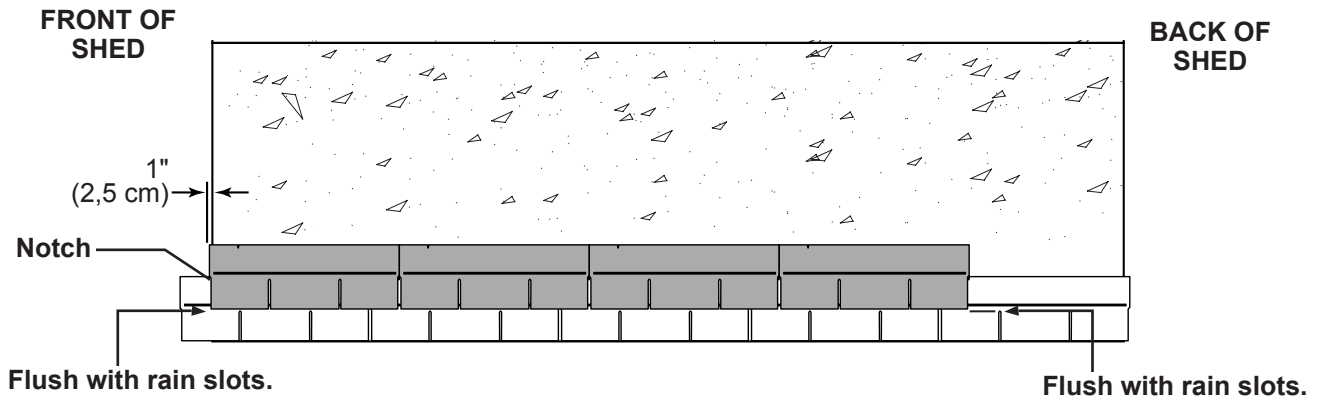

- 4 Continue installing rows of shingles by staggering at front.

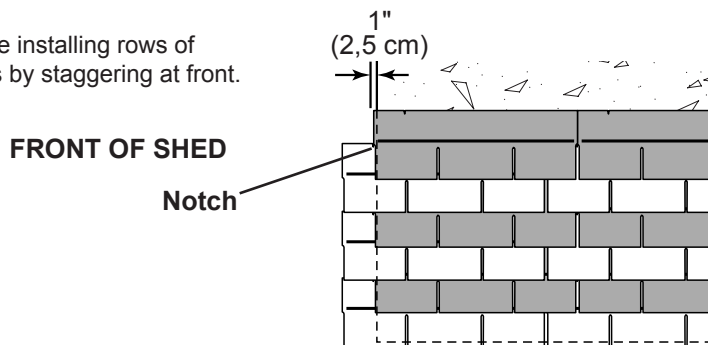

SHINGLES

continued...

- 5 Continue installing rows of shingles to the peak. At the peak make sure there is a maximum of 5" or less to the rain slot, as shown below. If shingles overlap at ridge cut to peak with a utility knife.

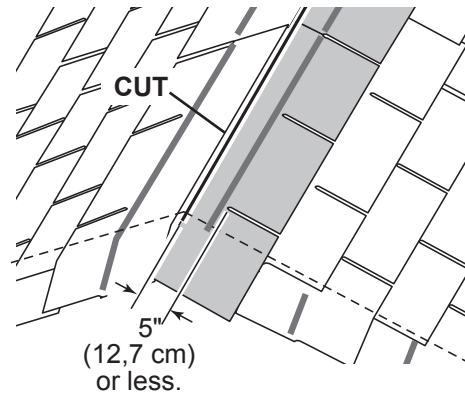
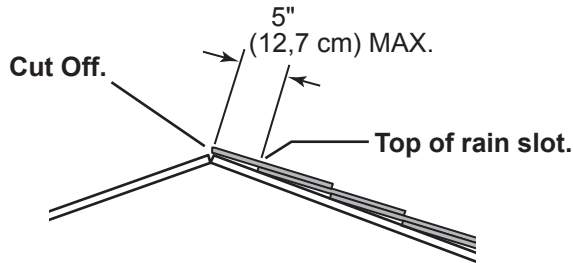

- ! • If more than 5" to rain slot you must install another row of shingles.

- 6 Repeat steps 1 - 5 to shingle the opposite side of your roof. Trim shingles at ridge.

- 7 Once both sides are shingled you need to trim ends. Strike a chalk line 1" from edge.

- 8 Using your shingle hooked blade carefully cut shingles along chalk line.

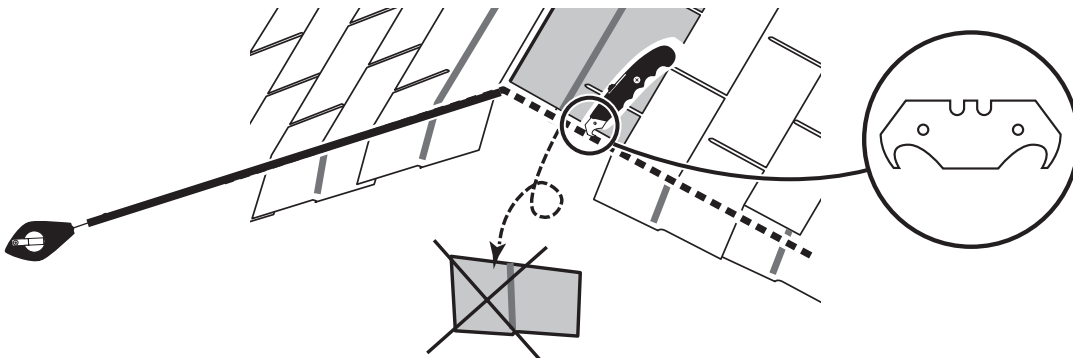

You have finished shingling your roof. Proceed to capping the ridge.

SHINGLES - RIDGE CAP

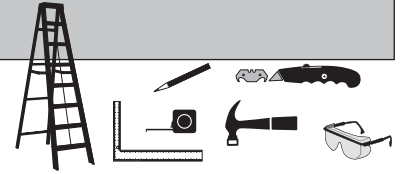

• You will finish off the top of the roof with a ridge cap made from shingles.

BEGIN

1 Cut shingles into THREE pieces. **Hint:** Use cut-off pieces first.

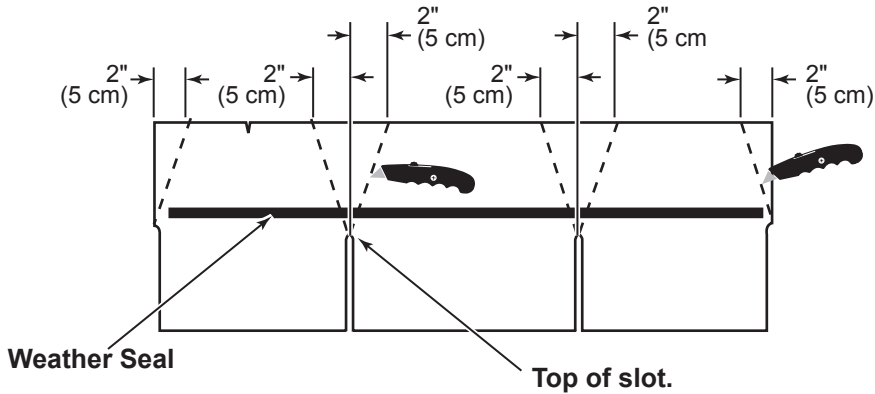

 Score shingle, then snap-off angled cut.

Note: • You will need about 30 - 32 cut pieces.

30 to 32 Pieces

2 Install first ridge cap flush to shingles at front, as shown.

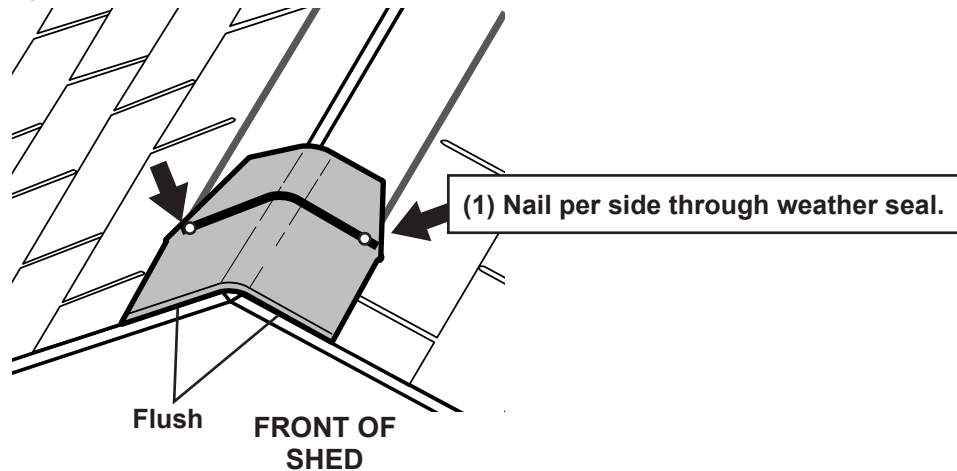

3 Install second ridge cap 5" back, as shown.

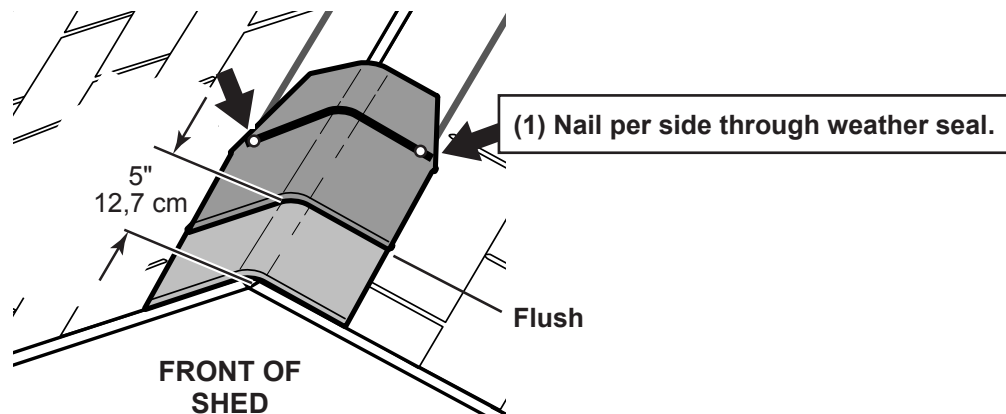

SHINGLES - RIDGE CAP

continued...

4 Continue installing ridge cap to back of roof.

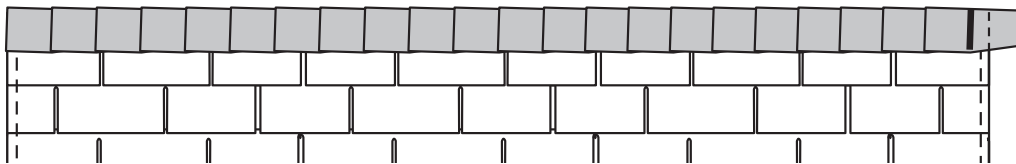

5 Make sure there is 4" between the shingle-color and edge of shingles.

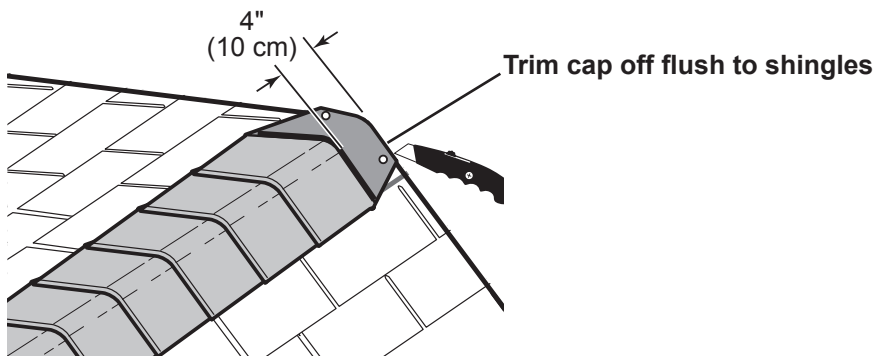

6 When you have 4" minimum of shingle color cut one piece to cap your roof.

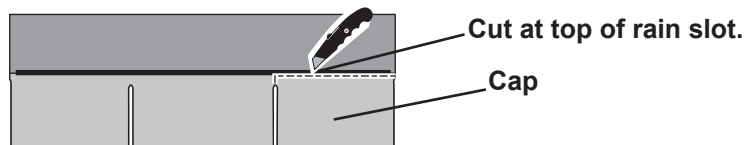

7 Install flush to shingles.

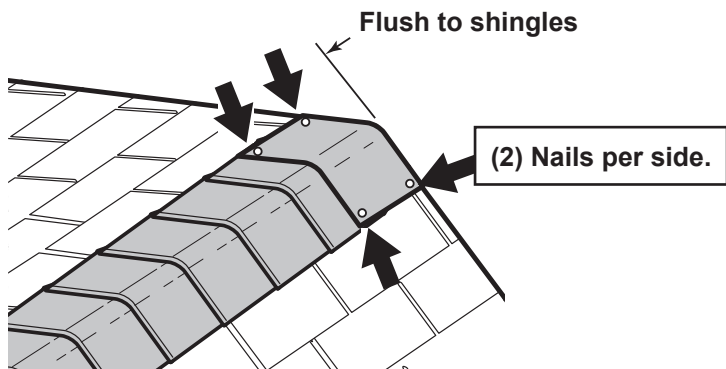

You have finished your ridge cap.

LIMITED CONDITIONAL WARRANTY*

Backyard Storage Solutions, LLC warrants the following:

1. Every product is warranted from defects in workmanship and manufacturing for 1 year.
2. All accessories, hardware and metal components are warranted for 2 years.
3. All Oriented Strand Board (OSB) is warranted for 2 years
4. Siding and Trim is warranted for 15 years.
5. LP Prostruct® Flooring is warranted for 10 years
6. Cedar lumber is warranted for 15 years.
7. Preserved Pine is warranted for 10 years.
8. Redwood is warranted for 10 years.
9. Metal Roof is warranted for 25 years.

Backyard Storage Solutions, LLC will repair, replace or pay for the affected part. In no event shall Backyard Storage Solutions, LLC pay the cost of labor or installation or any other costs related thereto. All warranties are from date of purchase. If a cash refund is paid on an affected part, it will be prorated from the date of purchase.

CONDITIONS

The warranty is effective only when:

1. The unit has been erected in accordance with the assembly instructions.
2. The unit has been properly shingled and painted or stained and reasonably and regularly maintained thereafter.
3. The failure occurs when the unit is owned by the original purchaser.
4. Backyard Storage Solutions, LLC has received the warranty registration card within thirty (30) days of purchase and notification of the failure in writing within the warranty period specified above.
5. Backyard Storage Solutions, LLC has had reasonable opportunity during the sixty (60) days following receipt of notification to inspect and verify the failure prior to commencement of any repair work.

REQUIREMENTS

Storage Buildings

To validate your warranty, it is necessary to properly maintain your Backyard Storage Solutions, LLC unit; shingle the roof and paint or solid-colored stain the siding using quality, 100% acrylic latex exterior product with a minimum of two (2) coats within thirty (30) days of assembly; caulk above all doors and all horizontal and vertical trim boards; paint and seal all exposed edges, sides and faces of siding/trim and OSB siding to include all exterior walls and all sides and all edges of doors.

Gazebos & Pergolas

To validate your warranty, it is necessary to properly maintain your Backyard Storage Solutions, LLC unit. This includes treating all of the exposed cedar and pine surfaces on your gazebo or pergola structure with an exterior grade wood preservative, an exterior oil-based semi-transparent stain, an acrylic latex exterior paint or an acrylic latex solid color exterior stain within 30 days of assembly and as needed thereafter to maintain your warranty.

Keep vegetation trimmed away from building and make sure siding panels and trim do not come in contact with masonry or cement. The minimum ground clearance for siding must be one half inch (½ inch) from concrete slab or two and one half inches (2 ½") from the ground when building is erected or constructed on a treated wood floor kit. Water from sprinklers must be kept off unit. In no event will Backyard Storage Solutions, LLC be responsible for any indirect, incidental, consequential or special damages nor for failure(s) that are caused by events, acts or omissions beyond our control including, but not limited to, misuse or improper assembly, improper maintenance (which eventually leads to rot or decay) and acts of God. Backyard Storage Solutions, LLC will not be held responsible for any labor costs incurred to construct your unit.

This warranty gives you certain specific rights that vary from state to state.

CLAIM PROCEDURE

To make a claim under this warranty, you can either call 1-888-827-9056 or email: customerservice@backyardproducts.com.

Please have ready the information below when you call or include the information in your email:

1. The model and size of the product.
2. A list of the part(s) for which the claim is made.
3. Proof of purchase of the Backyard Storage Solutions, LLC item, as shown on the original invoice or receipt.
4. Run code: found on exterior product label or assembly instructions enclosed in the product package.

All other inquiries can be mailed to:

Backyard Storage Solutions, LLC
Attn: Customer Service
1000 Ternes
Monroe, MI 48162

***WARRANTY TERMS MAY VARY OUTSIDE THE U.S.A.**

IMPORTANT: This is your warranty certificate.

15Y PSS BB GEN LDR: 3/20/2019