

POULANPRO

OPERATOR'S MANUAL

MODEL: PPW4400
4400 PSI Pressure Washer

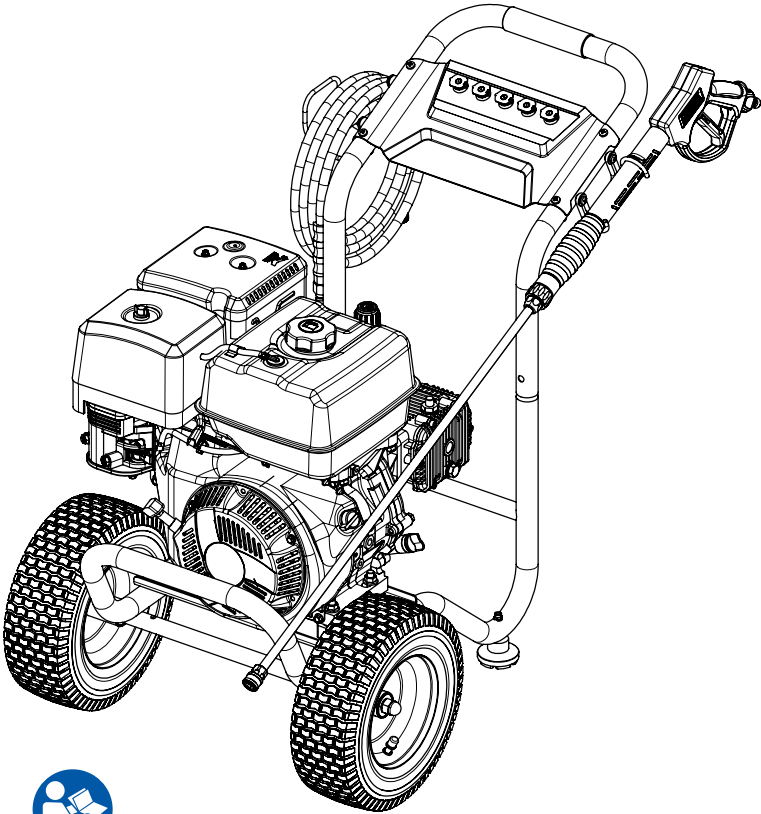

? Have product questions or need technical support?
Contact Us:

- Website: www.poulanpro.com
- Toll free: 1-888-676-7909 Mon-Fri 8-4 CST
- Email: support@poulanpro-power.us

Manufactured under license from Husqvarna AB
Poulan Pro is a registered Trademark of Husqvarna AB
Imported by Novus Performance Products.
W225N16708 Cedar Parl Ct. Jackson, WI

EN

Vol. 2025-04

CONTENTS

Specifications	3
Introduction / Safety Definitions	4
Important Safety Instructions	5
Know Your Product	10
Assembly	12
Operation	16
Maintenance	21
Transportation and Storage	26
Troubleshooting	27
Basic Service Parts List	28
Warranty Statement	29

SPECIFICATIONS

Model	PPW4400
Max Pressure	4400 PSI
Max Flow	6.34 GPM (24 L/min)
Pump Type	Triplex Plunger Pump
Pump Oil Type	SAE 15W-40
Pump Oil Capacity	12 fl oz. (350 ml)
Min Water Supply Flow Rate	6.3 GPM (24 L/min)
Min Water Supply Pressure	30 PSI (2.07 bar)
Max Inlet Water Temperature	104° F (40° C)
Spray Nozzles	0°, 15°, 25°, 40°, Soap - Quick Connect
Weight	139 lbs (63 kg)
Dimensions	Length: 50.39 in. (128 cm)
	Width: 24.40 in. (62 cm)
	Height: 32.1 in.(81.5 cm)

Engine

Engine Model	WM190F/P
Engine Displacement	420 cc
Engine Type	4-Stroke, Air Cooled, Overhead Valve (OHV)
Fuel Type	Fresh, clean regular unleaded gasoline with a minimum octane rating of 87 and ethanol content of no more than 10% by volume.
Fuel Capacity	1.2 gal.(4.6 L)
Spark Plug	F7RTC Torch / BPR7ES NGK
Spark Plug Gap	0.030 in. (0.7-0.8 mm)
Oil Type	SAE 10W-30
Oil Capacity	37 fl oz. (1.1 L)

INTRODUCTION

Congratulations on your purchase of a PoulanPro® branded product. This model is the result of our vast experience in the production of high- quality, cost-effective equipment.

It represents the high degree of reliability and innovation that PoulanPro® has dedicated itself to.

This manual will give you an understanding of the assembly, operation and basic maintenance of this unit. If you have any questions concerning the operation or maintenance, please contact us at support@poulanpro-power.us or 888-676-7909.

We want you to continue to use and be satisfied with your product for years to come, therefore please fully familiarize yourself, and others who plan on operating the product, with the proper safety and operation procedures before each use.

We continually seeks advancements in product design and quality. Therefore, while this manual contains the most current product information available at the time of printing, there may be minor discrepancies between your product and this manual.

When contacting us about parts and/or service, you will need to supply the complete product and serial numbers of your unit.

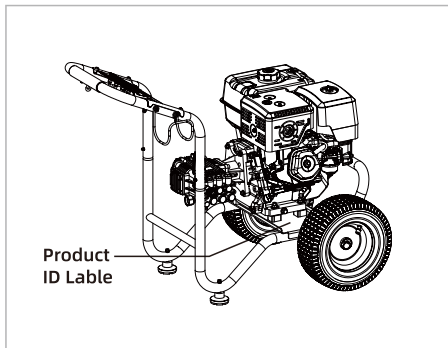

Record the following information to obtain service or warranty assistance

PRODUCT NUMBER
SERIAL NUMBER
DATE OF PURCHASE

SAFETY DEFINITIONS

The purpose of safety symbols is to attract your attention to possible dangers. The safety symbols, and their explanations, deserve your careful attention and understanding. The safety warnings do not by themselves eliminate any danger. The instructions or warnings they give are not substitutes for proper accident prevention measures.

⚠ DANGER

DANGER indicates a hazardous situation which, if not avoided, will result in death or serious injury.

⚠ WARNING

WARNING indicates a hazardous situation which, if not avoided, could result in death or serious injury.

⚠ CAUTION

CAUTION indicates a hazardous situation which, if not avoided, may result in minor or moderate injury.

🗨 NOTICE

NOTICE indicates information considered important, but not hazard-related (e.g., messages relating to property damage).

IMPORTANT SAFETY INSTRUCTIONS

⚠ DANGER

Engine exhaust contains carbon monoxide, a colorless, odorless, poisonous gas. Breathing carbon monoxide can cause headaches, nausea, dizziness, drowsiness, confusion, fainting or death. If you start to feel dizzy or weak, leave the area immediately, get fresh air and Seek Medical Treatment.

ALWAYS OPERATE EQUIPMENT OUTDOORS ONLY, IN A WELL-VENTILATED AREA.

Using an engine indoors CAN KILL YOU IN MINUTES. Engine exhaust contains carbon monoxide. This is a poison you cannot see or smell. Never start or operate gasoline powered equipment inside any building, including garages, basements, crawlspaces, sheds or other partially enclosed or confined areas.



Always use equipment **Outside Only**.

DO NOT allow exhaust fumes to enter a confined area through windows, doors, vents or other openings while operating the product.

⚠ WARNING

Before operating your machine, carefully read and understand all safety, controls and operating instructions in this Operator's Manual. Save these instructions. Refer to them frequently and use them to instruct others who may use this product.

DO NOT allow untrained individuals or children to operate this equipment.

Failure to follow these instructions could result in property damage, serious personal injury or death.

⚠ DANGER

Risk of injection or injury. High pressure jets can be dangerous if subject to misuse.

DO NOT direct discharge stream at persons, animals, electrical devices, or the machine itself.

ALWAYS point spray gun in safe direction. Every time you stop the engine, squeeze trigger of spray gun to relieve any trapped pressure.

⚠ DANGER

Keep Clear of spray nozzle.

DO NOT point the spray wand at a person, animal or yourself.

Always wear safety glasses or goggles and protective equipment (hearing protection, gloves, rubber boots, protective clothing) when operating or performing maintenance.

NEVER put hand or fingers over the spray tip while operating the unit.

NEVER try to stop or deflect leaks with any body part.

ALWAYS engage the trigger gun lockout when spraying is stopped even if only for a few moments.

⚠ WARNING

Risk of eye injury. Spray could splash back or propel objects, resulting in serious injury.

Always wear vented safety goggles when using or near this product. Safety glasses do not provide full protection.

Always wear protective clothing such as long-sleeved shirts, long pants and closed toe shoes when operating the pressure washer.

⚠ WARNING

Risk of electrocution. Contact with electrical power source can cause electric shock or burn.

Never spray near a power source or electrical outlet.

⚠ WARNING

Use of a pressure washer can create wet slippery surfaces causing loose footing and falls.

Operate the pressure washer on a level surface.

Always grasp the spray gun with two hands to reduce kickback and potential loss of footing.

Ensure there is proper drainage to disperse the water.

⚠ WARNING

The pressure washer should have a minimum of 5 feet clearance on all sides of buildings or other equipment during operation.

Always operate the unit on level ground.

DO NOT attempt to start or run a damaged unit

Do not operate this unit when you are tired, ill, or under the influence of alcohol, drugs, or medication.

Always inspect the unit before each use for loose fasteners, fuel leaks, etc. Replace damaged parts.

Maintain the equipment per maintenance instructions located in this Operator's Manual.

When transporting the unit, always check that the fuel valve is in the OFF position and fuel cap is securely in place.

⚠ WARNING

Always Operate equipment with guards in place.

Rotating parts can entangle hands, feet, hair, clothing and/or accessories. Amputation or severe laceration can result.

Keep hands and feet away from rotating parts.

Tie up long hair and remove jewelry.

DO NOT wear loose-fitting clothing, dangling drawstrings or items that could become caught.

⚠ WARNING

Before performing any service to the unit: The engine switch must be in the OFF position and the engine completely stopped. Allow the engine to cool down, remove and ground the spark plug wire.

⚠ WARNING

Running engines produce heat. Severe burns can occur on contact. Combustible material can catch fire on contact.

DO NOT touch hot surfaces.

Avoid contact with hot exhaust gases. Allow equipment to cool before touching.

When operating maintain at least 3 ft. (91.4 cm) of clearance on all sides to ensure adequate cooling.

Maintain at least 5 ft. (1.5 m) of clearance from combustible materials.

⚠ WARNING

Rapid retraction of the recoil cord will pull hand and arm towards the engine faster than you can let go. Broken bones, fractures, bruises or sprains could result. Unintentional startups can result in entanglement, traumatic amputation or laceration.

When starting the engine, pull the recoil cord slowly until resistance is felt and then pull rapidly to avoid kickback.

⚠ WARNING

Never spray flammable liquids

Never use flammable or corrosive detergents in the pressure washers soap tank.

Never use pressure washer in areas containing combustible dust, liquids or vapor.

🗨 NOTICE

Water under high pressure can damage surfaces.

Always: test first on a small inconspicuous area to understand if damage may occur.

Painted surfaces are very suspect to damage.

Never: Point the spray nozzle at persons, animals, glass surfaces or electrical components.

🗨 NOTICE

Only use Cold water.

Never Let the pump run dry. Be sure the water supply is turned on before operating the unit.

Never let water in the pump freeze. Freezing will cause internal pump damage and can void your warranty.

Operate only on level surfaces.

⚠ WARNING

Misuse of pressure washers is dangerous. The gun should not be aimed at people, live equipment, or the machine itself.

The resulting high-pressure water stream can cut through the skin and underlying tissues, never pull the trigger or aim the gun at other people, animals, plants, or fragile objects such as glass, even if the engine has stopped.

Do not leave the gun unattended while the equipment is running.

Make sure the gun, nozzles, and accessories are properly connected.

Never attempt to repair high-pressure water hose, be sure to replace them.

Never attempt to repair a leak with sealant and always replace an O-ring or seal.

Never attempt to connect or disconnect hoses from the pump or gun while the system is pressurized.

Be sure to release the water pressure in the appliance every time you stop the engine.

Fuel Safety

⚠ DANGER

GASOLINE AND GASOLINE VAPORS ARE HIGHLY FLAMMABLE AND EXPLOSIVE.

Fire or explosion can cause property damage, severe burns or death.

Gasoline and gasoline vapors:

Gasoline is highly flammable and explosive.

Gasoline can cause a fire or explosion if ignited.

Gasoline is a liquid fuel, but its vapors can ignite.

Gasoline is a skin irritant and needs to be cleaned up immediately if spilled on skin or clothes.

Gasoline has a distinctive odor; prolonged exposure to gasoline fumes could cause serious long-term consequences. Seek fresh air if exposed more than a few minutes.

Gasoline expands or contracts with ambient temperatures. Never fill the gasoline tank to full capacity, as gasoline needs room to expand when temperatures rise.

When adding or removing gasoline:

DO NOT light or smoke cigarettes while handling gasoline.

Always stop the engine and allow it to cool for a minimum of five minutes before refueling.

Never pump gasoline directly into the products fuel tank at the gas station.

Always fill or drain gasoline outdoors in a well-ventilated area.

Always loosen fuel cap slowly to release any vapor pressure and to keep fuel from escaping around the fuel cap.

Always replace and tighten the fuel cap securely after fueling.

Never remove the fuel cap or add fuel while the engine is running or when the engine is hot.

DO NOT overfill the gasoline tank.

DO NOT tip the product allowing fuel or oil to spill.

In the event of spilled fuel, allow the fuel to evaporate fully, then move the product 10 ft. (3m) away from the refueling site before starting the engine to avoid potential ignition of fuel vapors.

Safety Symbols

Some of the following symbols may be used on this product. Please study them and learn their meaning. Proper interpretation of these symbols will allow you to safely operate the product.

SYMBOL	MEANING
	Safety Alert Symbol. Indicates a potential personal injury hazard.
	Read Operator's Manual. To reduce the risk of injury, user must read and understand operator's manual before using this product.
	Toxic Fumes. Engine exhaust contains carbon monoxide, a poisonous gas that could kill you in minutes. You cannot smell it or see it.
	Risk of Fire. Fuel and its vapors are extremely flammable and explosive. Fire can cause severe burns or death. Do not add fuel while the product is operating or still hot.
	Risk of Injections. To reduce the risk of injection or injury, never direct a water stream towards people or pets or place any body part in the stream. Leaking hoses and fittings are also capable of causing injection injury. Do not hold hoses or fittings.
	Spray, Flying Objects. Risk of eye injury. Spray could splash back or propel objects resulting in serious injury.
	Hot Surface. To reduce the risk of injury or damage, avoid contact with any hot surface.
	Electric Shock. Contact with power source could cause electrical shock resulting in death or serious injury.
	Kickback. To reduce the risk of injury from kickback, hold the trigger gun securely with both hands when the machine is on.
	Chemical Burn. Chemicals could cause burns resulting in death or serious injury.
	Slippery Surface/Fall. Slippery wet surfaces could cause you to fall resulting in death or serious injury.

KNOW YOUR PRODUCT

Please read this manual thoroughly before operating your product. Familiarize yourself with the location and function of all controls and features. Failure to follow instructions could result in property damage, serious injury or death. Save this manual for future reference.

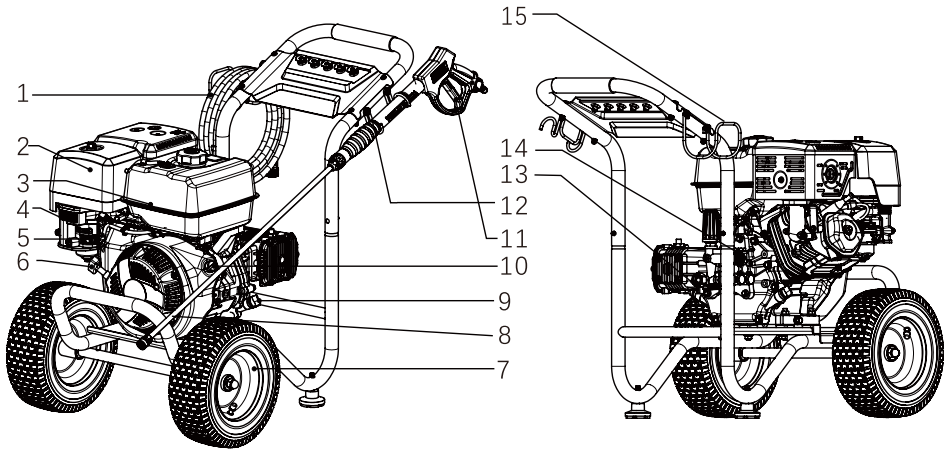

1	High Pressure Hose
2	Air Filter
3	Fuel Tank
4	Choke Lever
5	Fuel Valve Lever
6	Recoil Start Handle
7	Wheel
8	Spray Wand

9	Oil Dipstick / Fill Cap
10	Ignition ON / OFF Switch
11	Spray Gun
12	Spray Gun Holder
13	Garden Hose Inlet
14	High Pressure Hose Outlet
15	High Pressure Hose Holder

UNPACKING

Carefully remove the Pressure Washer out from the carton/box and place the unit on the ground or other solid surface. Do not discard the packaging until you have confirmed the following items are present.

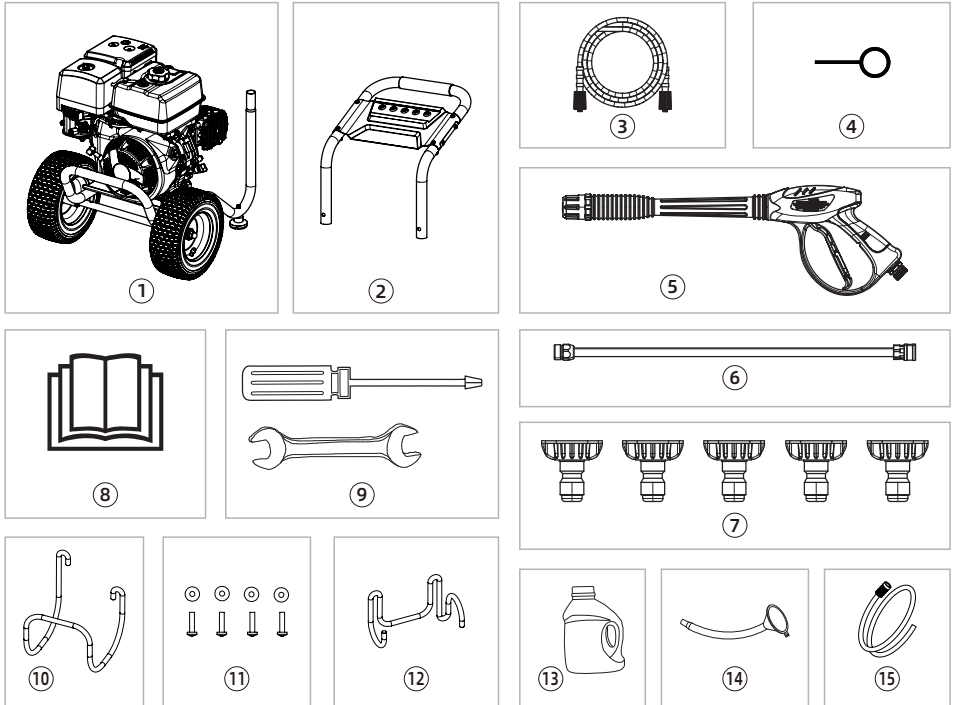

1	Main Unit	8	Operators Manual & Quick Start Guide
2	Upper Handle	9	Tools - Wrench 10/8mm, Screwdriver
3	High Pressure Hose	10	Wire Hanger - High Pressure Hose
4	Nozzle Cleaning Tool	11	4 x M6 Bolts, Washers
5	Spray Gun	12	Holder - Spray Gun
6	Spray Wand	13	Oil Bottle
7	Spray Nozzles (5 pcs) 0°, 15°, 25°, 40°, Soap	14	Oil Funnel with tube
		15	Chemical Injection Tube And Filter

Please contact our customer support team at 1-888-676-7909 if any of the above loose parts are missing from the carton.

ASSEMBLY

Your Pressure Washer requires limited assembly prior to use. If you have any questions regarding the assembly of this product, call our Technical Support Team at 1-888-676-7909 M-F 8am-4pm CST or by email at support@poulanpro-power.us Please have your model and serial number available at the time of the call.

1. Install the Upper Handle

Align the two ends of the upper handle (A) with the two upright tubes of the engine base (B), and then press down firmly until positioning pins pop into place on both sides.

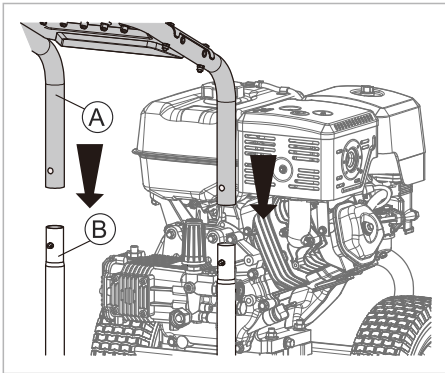

2. Install the high-pressure hose hook and spray gun hook

a. As shown in figure, install the high-pressure pipe hook (C) on the left side of the upper handle frame with 2 M6x25 bolts (A) 2 washers 6 (B).

b. As shown in figure, install the spray gun hook (D) on the right side of the upper handle frame with 2 M6x25 bolts (A) 2 washers 6 (B).

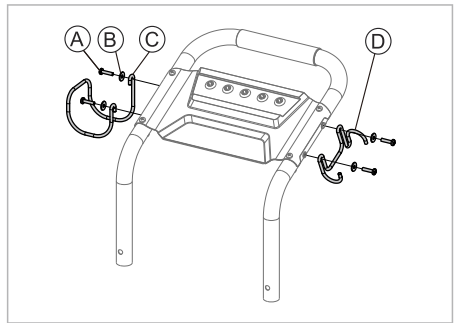

3. Spray Nozzles

Press the spray nozzles into their corresponding color matched openings on the pressure washer's top panel.

(A) Red = 0°, (B) Orange = 15°, (C) Green = 25°, (D) White = 40°, (E) Black = Soap

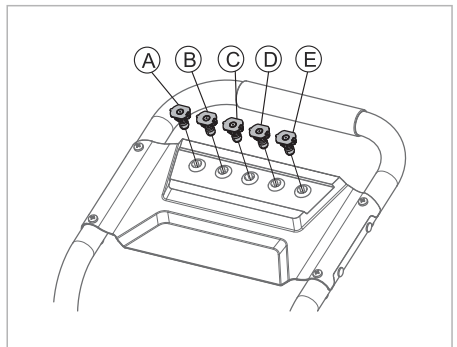

4. Pump Assembly

- a. Remove the red shipping plug from the Pump and replace with the included Pump Oil Dipstick.

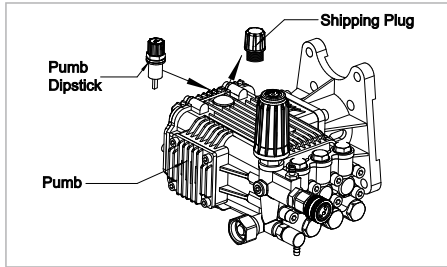

1. Place the unit on a flat, level surface.
2. Remove the oil dipstick by turning counterclockwise.
3. Using a funnel, add up to 37oz.(1.1L) of oil to the engine. The oil should be near the top thread of the filler neck.
4. Check the oil level using the dipstick. DO NOT screw in when checking.
5. When finished screw in the dipstick securely and replace the oil / dipstick access cover.

Recommended Engine Oil Type

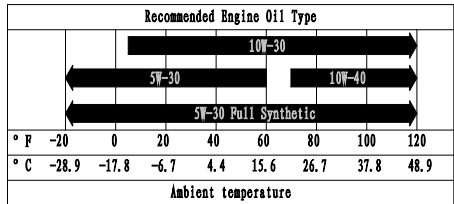

5.Add Engine Oil

CAUTION

This unit ships from our factory without oil. DO NOT attempt to crank or start the engine before it has been properly filled with the recommended type and amount of oil.

Running an engine with a low oil level can quickly cause engine damage. Damage to the engine resulting from failing to follow these instructions will void your warranty.

NOTE

SAE 10W-30 with a API service category of SJ or higher is recommended for general use. Other viscosities may be used when the average temperature is within the recommended range.

Engine / Dipstick Oil Level

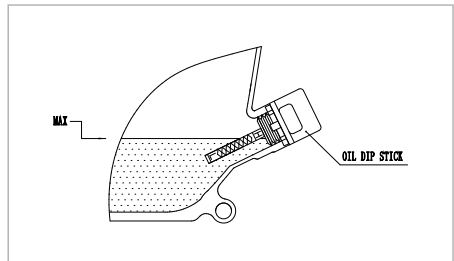

NOTE

Synthetic Oil may be used after the initial 20hr oil change. The use of synthetic oil does not change the recommended oil change intervals.

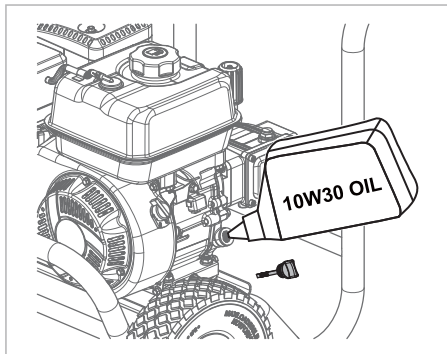

6.Add Fuel

The engine was designed to operate on unleaded gasoline with an octane rating of 87 or higher and a maximum ethanol content of 10% by volume.

The use of fuels with a content of ethanol greater than 10% can cause starting and/or performance problems, damage to metal, rubber and plastic parts of the fuel system. Engine performance problems or damage caused by using fuel with a higher ethanol content will not be considered for warranty.

⚠ DANGER

Gasoline and gasoline vapors are highly flammable and extremely explosive.

Always keep fuel away from sparks, open flames, pilot lights, heat and other sources of ignition.

Always Stop the engine and allow it to cool before refueling.

Only fill or drain fuel outdoors in a well-ventilated area.

DO NOT pump gasoline directly into the engine. Use an approved container to transfer the fuel to the engine.

Never use a gasoline container, gasoline tank, or any other fuel item that is broken, cut, torn or damaged.

DO NOT overfill the gasoline tank Wipe up spills immediately.

⚠ IMPORTANT

Use fresh, clean unleaded fuel with a minimum octane rating of 87 and a ethanol content of 10% or less by volume.

⚠ WARNING

Pouring gasoline too fast through the fuel screen may result in blow back of gasoline at the operator while filling.

Filling the Fuel Tank

1. Remove the fuel tank cap.
2. Slowly add gasoline to the tank until it reaches the Red fuel level indicator of the fuel screen. **DO NOT** overfill. A minimum of ¼ in. (6.4 mm) of space left in the tank is required for gasoline expansion.
3. Replace and tighten the fuel tank cap.
4. Immediately wipe up any spills.

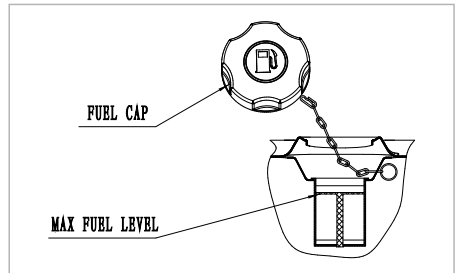

Notice: The engine works well with 10% or less ethanol blended gasoline. When using ethanol-gasoline blends there are some issues worth noting:

Ethanol-gasoline blends can absorb more water than gasoline alone.

These ethanol blends can eventually separate, leaving water or a watery goo in the tank, fuel valve and carburetor. The compromised gasoline can be drawn into the carburetor and cause a hard / no-start condition as well as damage to the carburetor and the entire fuel system. Creating potential hazards.

If a fuel stabilizer is used, confirm that it is formulated to work with ethanol-gasoline blends.

Any damages or hazards caused by using ethanol blended gasoline higher than 10% by volume, improperly stored gasoline, and/or improperly formulated stabilizers, are not covered by manufacturer's warranty.

It is advisable to always shut off the gasoline supply and run the engine to starvation after each use. See Storage instructions for extended non-use.

7. Assemble spray gun and high-pressure hose

- a. Attach the spray wand onto the gun by rotating the coupler nut clockwise until hand tight. Do not overtighten.

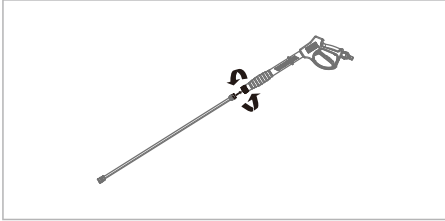

- b. Attach the high-pressure hose to the spray gun by pulling back on the quick connect collar of the high-pressure hose, slide the fitting on the spray gun into the quick connect and release the collar. Pull firmly on the hose to ensure it is secure.

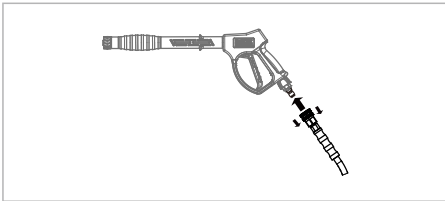

NOTICE

Never run the pressure washer without a water supply connected to the pump and turned on. Damage to the internal pump components will result.

Internal pump damage from running a dry pump is not covered under warranty.

- c. Uncoil and straighten the high-pressure hose to prevent kinks.
- d. Connect the open end of the high-pressure hose to the high-pressure outlet by pulling the quick connect collar back, inserting the high-pressure hose and releasing the collar. Pull firmly on the hose to ensure it is secure.

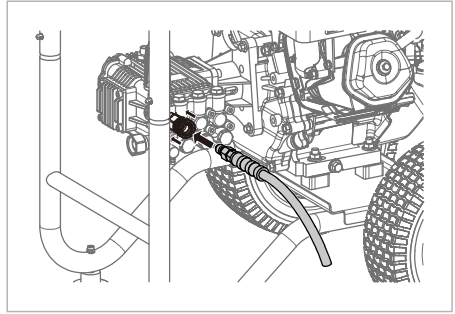

8. Connect Water Supply - Garden Hose

- e. Run water through the garden hose for a few seconds to flush out debris from the hose.
- f. Inspect the pump's inlet strainer and remove any debris. Check for damage and if found replace component.

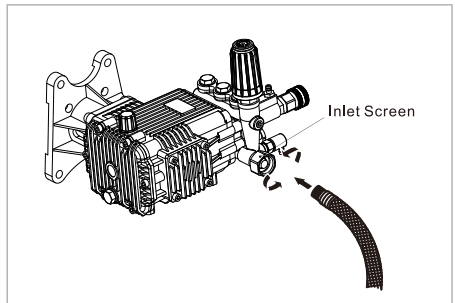

NOTICE

The water supply must come from a pressurized water source. (Between 40-80 psi)

Do not use a gravity fed tank. Never use hot water.

Garden hose is not to exceed 50ft.

There must be a minimum of 10 ft. (3 m) of unrestricted hose between the pressure washer and a pressurized source.

OPERATION

⚠ WARNING

Before operating your machine, carefully read and understand all safety, controls and operating instructions in this Operator’s Manual. Failure to follow these instructions can result in serious personal injury. Take the time to familiarize yourself with the controls and operation of the entire unit before use.

Connect Spray Nozzle

1. Engage the trigger safety lock on the spray gun.
2. Select a spray nozzle according to your cleaning needs.

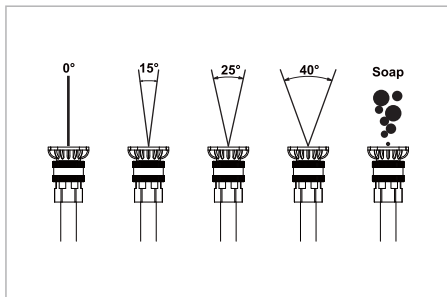

3. Pull back on the spray wand quick connect collar and insert the desired spray tip and release the collar. Tug on the spray tip to ensure it is firmly secure.

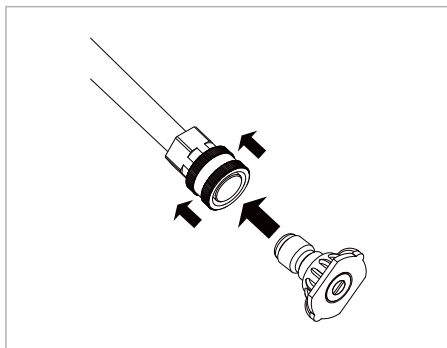

Nozzle Tip Color	Usage
Black	Low Pressure Use to apply Detergent
White 40°	General Cleaning - Deck, Patio, Fencing, Outdoor Equipment
Green 25°	Deep Cleaning - Siding, Gutters, Deck, Patio, Outdoor Furniture
Orange 15°	Concrete, Brick, Masonry, Blacktop, Paint & Rust Removal
Red 0°	Use with extreme Caution. Paint & Rust Removal, Concrete, Brick

Pressure Washer Location

Choosing a location is critical to your AND others’ safety. Please read, understand and consider all warnings when choosing the location.

A pressure washer must have at least 5 ft. (1.5 m) of clearance from combustible material and allow for adequate cooling,

Place the pressure washer on a flat level surface in a well-ventilated area.

DO NOT place the pressure washer near vents or intakes where exhaust fumes could be drawn into occupied or confined spaces.

Carefully consider wind and air currents when positioning pressure washer.

NOTE

Do Not start the engine without a water supply connected and turned on.

Important: Before Starting the Engine.

1. Uncoil and straighten out both the High-Pressure Hose and Water line.
2. Turn on the water supply to the pressure washer.
3. Squeeze and hold the trigger on the spray gun until a steady stream of water is flowing from the spray nozzle tip. (10 - 15 seconds)

Starting the Engine

1. Check oil level and add oil if necessary.
2. Make certain the unit is on a flat, level surface.
3. Slide the Choke Lever (A) to the full CHOKE position (Fully Left).
4. Move the Fuel Valve lever (B) to the ON position (Fully Right).
5. Turn the Engine ignition switch (C) to the ON position.

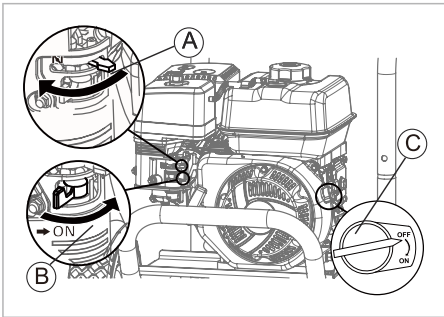

6. Pull the starter handle slowly until resistance is felt, then pull rapidly. Note: Return the starter handle slowly back to the engine to prevent damage to the starter.
7. Once the engine starts, slowly slide the CHOKE lever to the OFF position. (Fully Right).

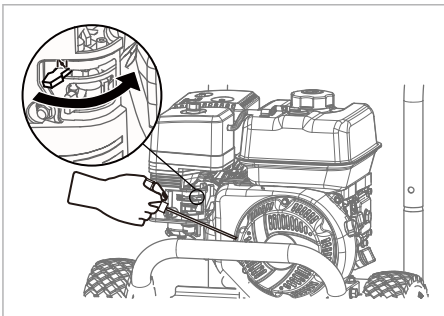

NOTE

If the engine does not start after 2 pulls, relieve the pump pressure by pulling the trigger on the spray gun.

WARNING

Rapid retraction of the recoil cord will pull hand and arm towards the engine faster than you can let go. Broken bones, fractures, bruises or sprains could result. Unintentional startups can result in entanglement, traumatic amputation or laceration.

When starting the engine, pull the recoil cord slowly until resistance is felt and then pull rapidly to avoid kickback.

If after several attempts the engine still does not start, contact our Technical Support Team at 1-888-676-7909 Mon-Fri 8-4 CST or Email: support@poulanpro-power.us

Stopping the Engine

In an Emergency:

Turn the engine switch to the "OFF" position.

Under Normal Operation:

1. Move the Fuel Valve Lever fully to the left. (OFF position).

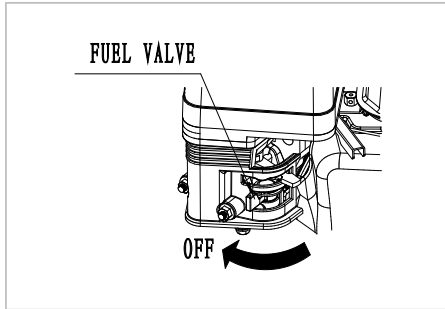

2. Turn the engine ignition switch to the OFF position.

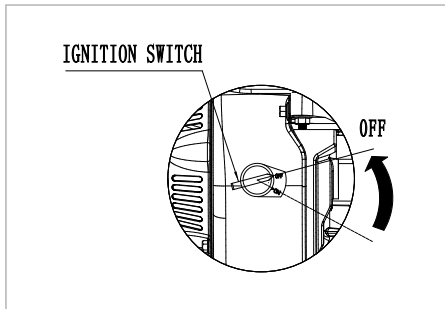

Pressure Washer Operation

⚠ DANGER

Risk of injection or injury. High pressure jets can be dangerous if subject to misuse.

DO NOT direct discharge stream at persons, animals, electrical devices, or the machine itself.

ALWAYS point spray gun in safe direction. Every time you stop the engine, squeeze trigger of spray gun to relieve any trapped pressure.

⚠ WARNING

Use of a pressure washer can create wet slippery surfaces causing loose footing and falls.

Operate the pressure washer on a level surface.

Always grasp the spray gun with two hands to reduce kickback and potential loss of footing.

Ensure there is proper drainage to disperse the water.

⚠ WARNING

Risk of eye injury. Spray could splash back or propel objects, resulting in serious injury.

Always wear vented safety goggles when using or near this product. Safety glasses do not provide full protection.

Always wear protective clothing such as long-sleeved shirts, long pants and closed toe shoes when operating the pressure washer.

Pressure Washing

Once the engine is started firmly grasp the spray gun with both hands. Point the spray gun in a safe direction, disengage the spray gun trigger lock by pressing down until it clicks into the back of the trigger.

- a. Depress the spray gun trigger to begin spraying.
- b. Release the trigger to stop spraying.

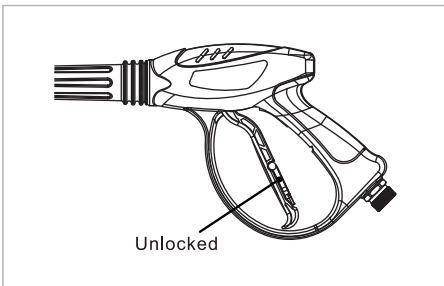
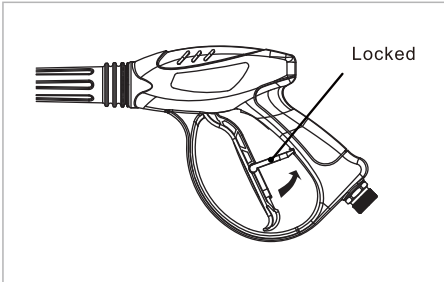

Spraying Tips

For most cleaning, keep nozzle 8 - 24 in. (20 - 61 cm) away from cleaning surface.

- 1. Test a small area first to understand if damage may occur.
- 2. Continuously move the spray to evenly rinse the surface to be cleaned.
- 3. When beginning to spray, start farther away and move closer to avoid damage to the surface.
- 4. Damage may occur to the cleaning surface if you spray too close, especially with high-pressure nozzles.



Shut Down

To reduce the risk of bodily injury or property damage, **Always** follow the procedure below once work is completed.

CAUTION

In the event the pump gets too hot a thermal relief valve on the pump will open and release hot water.

Running the unit for more than 1 minute without spraying water will cause heat to build up in the pump and cause damage to the pump's internal components which is not covered under warranty.

NOTE

Never operate your pressure washer without water.

Never connect your pressure washer to a hot water source.

WARNING

NEVER disconnect the high-pressure hose from the machine while the system is pressurized.

- 1. Engage the spray gun safety lock.
- 2. Shut down the engine as per the recommended procedure.
- 3. Turn off the water supply to the pressure washer.
- 4. Disengage the spray gun safety lock and squeeze the trigger for at least 15 seconds to depressurize the system.
- 5. Re-engage the trigger lock on the spray gun.

Use of Detergents

NOTICE

Use only detergents designed for pressure washers.

Do not use household detergents, acids, alkaline, bleaches, solvents, flammable material, or industrial grade solutions, which can damage the pump or cause property damage. Many detergents may require mixing prior to use. Prepare cleaning solution as instructed on the solution bottle. Always test in an inconspicuous area first.

NOTICE

Detergent Dilution Ratio

Follow the pressure washer detergent manufactures instructions for proper mix ratios.

Detergent will only be drawn through the spray gun with the black soap nozzle attached to the end of the spray wand.

1. Prepare the detergent solution as per the detergents manufacturer's instructions.
2. With the pressure washer shut off, connect the chemical injection hose onto the barbed fitting on the pump outlet.
3. Insert the filter screen end of the detergent suction hose into the detergent bottle or container.
4. With the trigger safety lock on the spray gun in the locked position, install the quick connect (Black) soap nozzle into the spray wand.
5. Turn on the water supply to the pressure washer.
6. Start the engine and pull the trigger on the spray gun to begin spraying the detergent.
 - a. For best results spray the surface evenly with overlaps.
7. Once the detergent is fully applied to the surface being cleaned, remove the detergent suction hose and filter screen from the detergent container and begin rinsing.

Flushing the system

To prevent leftover detergent from clogging or gumming up the injection system it is important to flush it with clear water after use.

1. If necessary, re-install the soap nozzle (BLACK).
2. Submerge the filter screen end of the detergent hose into a container of clear water.
3. Operate the pressure washer for 1 - 2 minutes.
4. Once clean, stop the engine.
5. Turn off water supply.
6. Point spray gun in a safe direction. Squeeze the trigger to release pressure within the system.

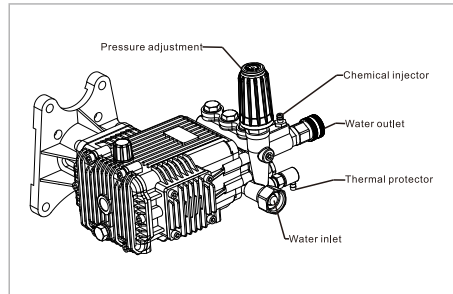

MAINTENANCE

Proper maintenance of your unit is important for maximum performance and a long service life.

To help you properly care for your unit, the following section includes a maintenance schedule and simple maintenance procedures. We suggest working with an Authorized Dealer, professional or qualified mechanic for any service which you are unfamiliar with, not mechanically proficient with or possessing the proper tools.

The maintenance schedule provided applies to normal operating conditions. If your unit is operated under more severe conditions such as high-temperatures, sustained high-load or operation in dusty or unusually wet conditions, please inspect and service your unit more frequently.

DANGER

DO NOT use gasoline or low flash point solvents to clean the engine or any of its components. The possibility exists of fire or explosion which can damage the equipment and cause severe bodily harm or even DEATH.

WARNING

Some maintenance operations may require a running engine. ALWAYS make sure the maintenance area is well ventilated. Gasoline engine exhaust contains poisonous carbon monoxide gas that can result in unconsciousness and/or DEATH when inhaled.

CAUTION

ALWAYS allow the engine to cool before servicing. NEVER attempt to service a hot engine.

CAUTION

ALWAYS disconnect the spark plug wire from the spark plug and secure it away from the engine before performing maintenance or adjustments.

Failure to follow these instructions can result in serious personal injury or property damage.

NOTICE

Maintenance, replacement, or repair of emission control devices and systems may be performed by any non-road engine repair establishment or individual.

Maintenance Schedule

Recommended Maintenance Schedule		Each Use	First 20 Hours or 1 Month	Every 50 Hours or 3 Months	Every 100 Hours or Every Season	Every 300 Hours	Before Storage
Engine Oil	Check	X					
	Replace		X		X (1)		
Air Filter	Check		X	X	X		
	Clean			X(1)	X (1)		
Spark Plug	Check		X		X		
	Replace				X	X	
Fuel	Check Level	X					
	Drain						X
Fuel Lines	Check				X		X
	Replace					X	
Hardware-Bolts/Nuts	Check		X		X		
Carburetor	Drain						X
Air Cooling System	Clean				X		
Valve Clearance	Check-Adjust					X (2)	
Pump - Damage / Leaks	Check	X					
Pump Oil	Check	X					
	Change			X (3)		X (3)	
Spray Gun	Check	X					X
High Pressure Hose	Check	X					
	Drain	X					
Spray Gun O-rings	Check / Lube	X		X			
Water Inlet Screen	Check / Clean	X					X

1. Service more frequently when used in dusty conditions - Replace if worn or damaged.
2. These items should be maintained and repaired by an authorized dealer, unless the owner has appropriate tools and is proficient with mechanical maintenance.
3. Pump Oil change - After first 50 hours of use. Then every 500 hours thereafter.

Oil Change

NOTICE

Used oil is a hazardous waste product and must be disposed of properly. Check your local regulations for proper disposal/recycling facilities.

Change the engine oil after the first 20 hours of use. Thereafter, change the oil every 100 hours of use or every season. Change the oil more often if used in dusty conditions.

If possible, drain the oil while the engine is warm. Warm oil drains more quickly and completely.

Refer to the adding engine oil section for the recommended oil for your operating environment.

1. Place the pressure washer on a flat level surface.
2. Place a suitable container below the oil drain plug to catch the used oil.
3. Remove the oil filler cap/dipstick and the drain plug bolt and sealing washer from the engine.
4. Allow the oil to drain completely from the engine.
5. Reinstall and tighten the drain plug bolt with sealing washer.
6. Using a funnel, add up to 20.3 fl. oz. (0.6 L) of oil to the engine.
7. Check the oil level using the dipstick. DO NOT screw in when checking.
8. When finished screw in the dipstick / oil fill cap securely.

NOTICE

Dispose of the used oil in accordance with local laws and regulations.

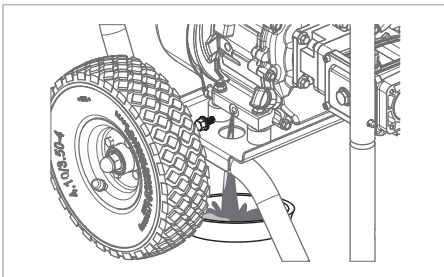

Air Filter

Check the air filter after the first 20 hours of use and clean the filter every 50 hours of use. Clean the filter more often when operating in a dusty environment. Replacement of the air filter is highly recommended at the first sign of excessive dirt build-up, element breakdown, wear or damage.

Inspection & Cleaning

1. Remove the outer wing nut and air filter cover.
2. Unscrew the inner wing nut and remove the air filter element.
3. Remove the outer foam pre-filter from the paper filter. Check both elements for tears or holes. Replace the filter if damaged.
4. Paper Element - To remove the dirt, tap it several times on a hard surface. Replace the element if excessively dirty. Do Not use pressurized air or solvents to clean the air filter as damage can occur.
5. Foam Pre-Cleaner - Clean the pre-cleaner in warm soapy water and rinse. Squeeze out excess water from the filter and allow to dry completely before installation.
6. Being careful to prevent dirt from entering the air duct leading to the carburetor, wipe any dirt from the air filter housing and cover.
7. Install the foam pre-filter over the air filter element, install onto the housing. Secure the air filter with the inner wing nut making sure it is sitting flat and sealing on the housing base. Install the air cleaner cover and tighten the outer wing nut.

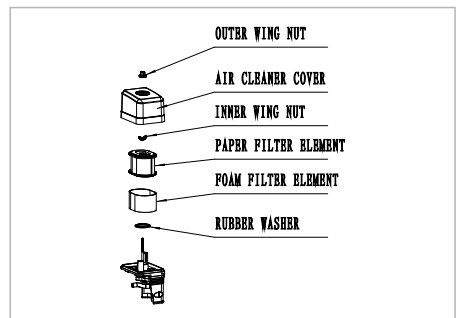

Spark Plug

The spark plug is an important part of the engine and its operation and should be checked regularly.

Check the spark plug after the first 20 hours and every 100 hours of operation thereafter. Replace the spark plug after 300 hours of operation.

Recommended Spark Plug: Torch F7RTC or Equivalent

Spark Plug Gap: .028 - .031 in. (0.7-0.8mm)

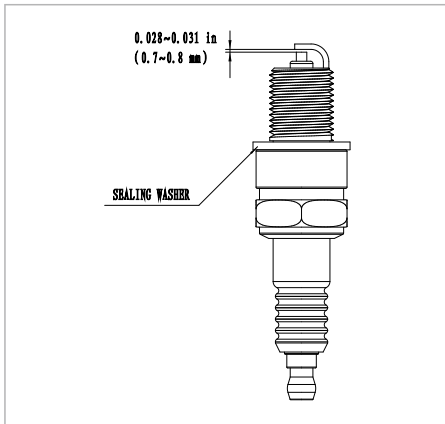

Spark Plug Cleaning / Adjusting / Replacement

1. Remove the spark plug cap and clear away any dirt around the spark plug base.
2. Using a spark plug wrench, remove the spark plug.
3. Visually check the spark plug. Clean with a steel brush. If the insulator is damaged, replace the spark plug.
4. Measure the spark plug gap with a suitable gauge. Adjust the spark plug gap as necessary by carefully bending the ground electrode.
5. To prevent cross threading, thread the spark plug in by hand until it seats, then tighten with a spark plug wrench as follows.

New Spark Plug - Tighten ½ turn after the plug seats to the cylinder head.

Used Spark Plug - Tighten ½ to ¼ turn after the plug seats to the cylinder head.

6. Reconnect the spark plug cap.

⚠ CAUTION

Always allow the engine to cool before performing maintenance, adjustments or service.

🗨 NOTICE

A loose spark plug can overheat and damage the engine

Pressure Washer

1. High Pressure Hose

- a. Inspect high-pressure hose for cuts, bulges, or leaks due to kinks or abrasion. If damage is found, replaced immediately.
- b. Inspect the connection fittings for dents, cracks, abrasions or other damage. Replace if found.

2. Spray Gun

- a. Lubricate the o-ring at the wand / gun unio. Inspect for cracks or damage. Replace if needed.
- b. Check the operation of the spray gun trigger to ensure it springs back when released. Inspect the trigger lock for proper function.

3. Water Inlet

Check & clean the water inlet screen (water supply line side). If screen or gasket are damaged replace.

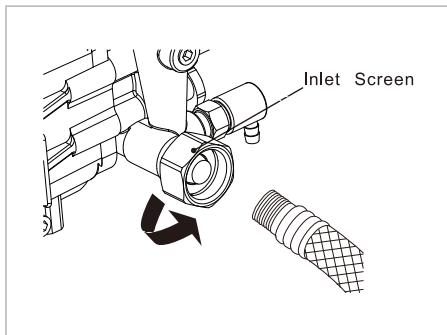

4. Spray Nozzles

Using a nozzle cleaning tool or small wire to loosen up any particles or debris in the nozzle and flush with water.

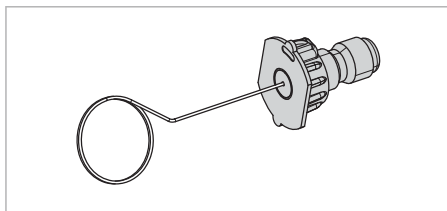

5. Detergent Siphoning Check Ball

The check ball in the detergent siphoning system can become stuck from mineral deposits or dried detergent. To free up the check ball perform the following.

- a. Remove the detergent hose from the barbed fitting of the check valve. (located on pump).
- b. Insert the nozzle cleaning tool or small wire into the barbed fitting and push down until the check ball moves.
- c. Reinstall the detergent hose onto the check valve fitting.

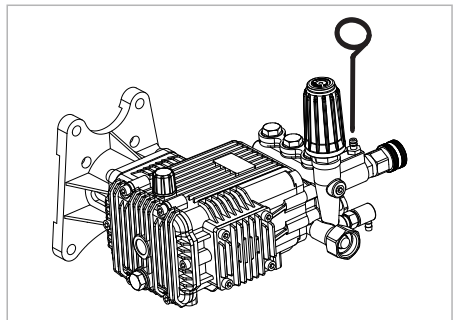

6. Change Pump Oil

The recommended oil change is after the first 50 hours of use. Then every 500 hours.

- a. Turn off engine.
- b. Clean the area around the oil pump dipstick and drain bolt.
- c. Place a pan under the drain bolt to collect the oil.
- d. Remove the oil drain bolt and dipstick from the pump and allow to drain.

Once drained completely, reinstall the oil drain plug and refill the pump. SAE 15W-40 12 oz. (0.35mL)

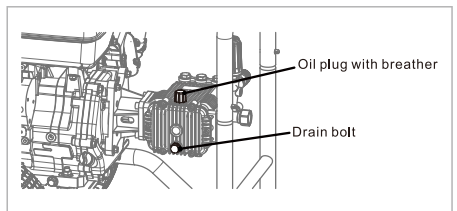

TRANSPORTATION AND STORAGE

Transporting

If the unit has been running, allow it to cool before transporting. A hot muffler can cause burns and/or ignite nearby materials. To prevent fuel spills, always transport the pump in an upright position.

1. Turn the Engine switch to the OFF position.
2. Move the Fuel Valve Lever to the OFF position.
3. Strap or tie the unit down to prevent any sliding or tipping.

Off-Season Storage

Storage preparation is important for keeping your unit running trouble free, easier to start after storage and the overall service life of your unit.

When the unit will not be used for more than 30 days, prepare it for storage as follows:

▲ DANGER

GASOLINE AND GASOLINE VAPORS ARE HIGHLY FLAMMABLE AND EXPLOSIVE.

Fire or explosion can cause property damage, severe burns or death.

Only fill or drain fuel outdoors in a well-ventilated area.

▲ CAUTION

Always allow the engine to cool before performing maintenance, adjustments or service.

Engine

It is important to prevent gum deposits from forming in essential fuel system parts such as carburetor, fuel hose, or tank during storage.

Fuel Stabilizer

Fuel stabilizers are an acceptable alternative in minimizing the formation of fuel gum deposits during storage. Add stabilizer to gasoline in fuel tank or storage container. Always follow the mix ratio found on stabilizer container. Run the engine at least 10 minutes after adding stabilizer to allow the stabilizer to reach the carburetor. Do not empty the gas tank and carburetor if using fuel stabilizer.

Drain the fuel tank and carburetor

1. Move the fuel valve lever to the OFF position.
2. Remove the carburetor drain screw and drain fuel into an approved gasoline container.
3. Slide the fuel valve lever to the ON position, allowing the fuel from the fuel tank to completely drain through the carburetor bowl.
4. Once draining is complete, reinstall the carburetor drain screw.
5. Move the Fuel valve lever to the OFF position.
6. Properly handle and dispose of drained fuel.

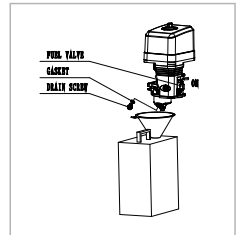

Oil

1. Change the engine oil. (See "Oil Change" in the Maintenance section)
2. Remove the Spark Plug.
3. Pour approximately one teaspoon of clean engine oil (5 cc) into the spark plug hole.
4. Slowly pull the starter rope several times to lubricate the cylinder walls of the engine.
5. Replace the spark plug and tighten 1/8 to 1/4 turn after the spark plug seats to the cylinder head.

Pump

1. Disconnect and drain all hoses, spray gun and spray wand.
2. Remove all liquids from the pump by slowly pulling the recoil handle 6-8 times.
3. The use of a pump protector product is recommended. If not available, connect a 3 ft. (1 m) of garden hose to the water inlet. Pour approx.. 6 oz (177.4 mL) of RV-antifreeze into the hose, then pull the recoil handle several times until the antifreeze exits the pump high pressure outlet.

Storage Location

Store your unit in a dry, well-ventilated place out of direct sunlight. Place a fabric cover over the unit. Do not use a plastic or vinyl cover as condensation could be trapped underneath which could increase the chances of rusting.

TROUBLESHOOTING

Problem	Cause	Solution
Engine does not start	Dirty or Faulty Spark Plug.	Clean and adjust or replace spark plug.
	Spark plug wire loose.	Reconnect wire.
	Fuel tank is empty.	Refuel.
	Choke control in incorrect position.	Move switch to CHOKE position.
	Old fuel or water in fuel.	Drain the fuel tank and carburetor. Refuel with fresh gasoline.
	Dirty air filter.	Clean or replace filter.
	Switch is in "OFF" position.	Turn switch to "ON" position.
	Low Oil Level.	Fill to proper level, place on flat, level surface.
Engine runs poorly	No spark.	Check engine switch is in ON position, Check oil level, Check / replace spark plug.
	Defective or incorrectly gapped spark plug.	Inspect spark plug gap or replace spark plug.
	Plugged spark arrestor screen.	Clean spark arrestor.
	Dirty air filter.	Clean or replace the air filter.
The engine starts, then shuts down after a short period	Stale gasoline.	Drain the fuel tank and carburetor. Refuel with fresh gasoline.
	Low fuel level.	Refuel.
	Low oil level.	Add engine oil.
	Float in carburetor is damaged or sticking.	Have the carburetor cleaned or rebuilt.
	Fuel is contaminated or deteriorated.	Drain & replace the fuel in the fuel tank and carburetor bowl.
The pump does not produce pressure, loss of pressure, low water volume	Carbon deposit and buildup on spark plug electrode.	Clean and re-gap or replace spark plug.
	Water supply is restricted.	Check hose for leaks, links, blockage.
	Garden hose is too small.	Replace with min 5/8" hose.
	Inlet filter screen is clogged.	Clean out and rinse filter screen.
	Low water pressure at inlet.	Turn garden hose on to full force.
	Spray tip is obstructed.	Clean spray tip.
Soap wash is not functioning	Connections, high pressure hose or spray gun leak.	Tighten connections, replace O-rings or replace failed piece.
	High pressure spray nozzle is installed.	Replace with (Black) low pressure soap nozzle.
	Detergent siphoning hose is clogged, cracked or not connected.	Check siphoning hose connection, blockage or cracks. Clean or replace as needed.
Recoil start handle won't or is hard to pull	Check ball is stuck in detergent siphoning system.	Free the check ball. See Maintenance.
	Pump has built up pressure from attempted starts or failure to relieve pump pressure.	Pull spray gun trigger before each starting attempt and after 2 pulls of the recoil.

BASIC SERVICE PARTS LIST

For additional service or parts assistance, Contact Us at 1-888-676-7909 or visit the support page of our website at www.poulanpro.com.

Basic Common Service Parts

Service Part	Part Number
Spark Plug - F7RTC	2204700002-0001
Air Filter Assy w/pre-cleaner	1901100165-0001
Dipstick Assy	1101500004-0001
Fuel Cap	1800900009-0001
Oil Drain Bolt	360290006
Sealing Washer - Oil Drain	3412100002-0001
Engine On / Off Switch	2205000001-0001
Recoil Starter Assy	2000100359-0001
High Pressure Hose	3901100004-0001
Spray Wand	3901000002-0001
Spray Gun	3900900002-0001
Spray Nozzle - Black Soap	3901200005-0001
Spray Nozzle - White 40°	3901200009-0001
Spray Nozzle - Green 25°	3901200008-0001
Spray Nozzle - Orange 15°	3901200007-0001
Spray Nozzle - Red 0°	3901200006-0001

WARRANTY STATEMENT

2-Year Limited Warranty Terms and Conditions

PoulanPro® is a registered trademark of Husqvarna AB and is used under license to Novus Performance Products LLC. Novus products are warranted for two (2) years against defects in materials or workmanship when put to ordinary and normal consumer use; ninety (90) days for any other use.

For the purposes of all the above warranties, "ordinary and normal consumer use" refers to non-commercial residential use and does not include misuse, accidents or damage due to inadequate maintenance. Novus Performance Products LLC certifies that Novus Products are fit for ordinary purposes for which a product of this type is used. Novus Performance Products LLC, however, limits the implied warranties of merchantability and fitness in duration to a period of two (2) years in consumer use, ninety (90) days for any other use.

The 2-Year Limited Warranty on Novus Products starts on the purchase date. The 2-Year Limited Warranty is applicable only to the original owner.

The warranty holder is responsible for the performance of the required maintenance as defined by the manufacturer's owner's manuals. The warranty holder is responsible for replacement of normally wearing parts such as the Belt, Shear Pins, Spark Plug and Air Filter. Accessories to the machine are not covered by this warranty.

During the warranty period, the warranty holder is responsible for the machine transportation charges, if required.

During the warranty period, warranty parts will be shipped by standard method at no charge to the warranty holder. Expedited shipping of warranty parts is the responsibility of the warranty holder.

SOME STATES DO NOT ALLOW LIMITATIONS ON THE LENGTH OF IMPLIED WARRANTIES, SO THE ABOVE LIMITATIONS MAY NOT APPLY TO YOU.

Novus Performance Products LLC shall not be liable under any circumstances for any incidental or consequential damages or expenses of any kind, including, but not limited to, cost of equipment rentals, loss of profit, or cost of hiring services to perform tasks normally performed by Novus Products.

SOME STATES DO NOT ALLOW THE EXCLUSION OR LIMITATION OF INCIDENTAL OR CONSEQUENTIAL DAMAGES, SO THE ABOVE LIMITATIONS MAY NOT APPLY TO YOU.

THIS WARRANTY GIVES YOU SPECIFIC LEGAL RIGHTS, AND YOU ALSO HAVE OTHER RIGHTS, WHICH VARY FROM STATE TO STATE.

Technical Support:

Toll free: 1-888-676-7909 Mon-Fri 8-4 CST

Email: support@poulanpro-power.us

U.S. FEDERAL EMISSION CONTROL WARRANTY STATEMENT YOUR WARRANTY RIGHTS AND OBLIGATIONS

The United States Environmental Protection Agency and Novus Performance Products LLC (Novus) are pleased to explain the emissions control system warranty on your 2024-2025 small off-road engine/equipment (SORE). In the United States, new equipment that use small off-road engines must be designed, built, and equipped to meet the State's stringent anti-smog standards. Novus must warrant the emissions control system on your small off-road engine/equipment for the periods of time listed below there has been no abuse, neglect or improper maintenance of your small off-road engine or equipment leading to the failure of the emissions control system.

Your emissions control system may include parts such as the carburetor or fuel-injection system, the ignition system, catalytic converter, fuel tanks, fuel lines (for liquid fuel and fuel vapors), fuel caps, valves, canisters, filters, clamps and other associated components. Also included may be hoses, belts, connectors, and other emission-related assemblies.

Where a warrantable condition exists, Novus will repair your small off-road engine/equipment at no cost to you including diagnosis, parts and labor.

MANUFACTURER'S WARRANTY COVERAGE:

This emissions control system on your small off-road engine/equipment is warranted for two years. If any emission-related part on your small off-road engine/equipment is defective, the part will be repaired or replaced by Novus.

OWNER'S WARRANTY RESPONSIBILITIES:

As the small off-road engine/equipment owner, you are responsible for the performance of the required maintenance listed in your owner's manual. Novus recommends that you retain all receipts covering maintenance on your small off-road engine/equipment, but Novus cannot deny warranty coverage solely for the lack of receipts or for your failure to ensure the performance of all scheduled maintenance.

As the small off-road engine/equipment owner, you should however be aware that Novus may deny you warranty coverage if your small off-road engine/equipment or a part has failed due to abuse, neglect, or improper maintenance or unapproved modifications.

You are responsible for presenting your small off-road engine/equipment to a Novus distribution center or service center as soon as the problem exists. The warranty repairs shall be completed in a reasonable amount of time, not to exceed 30 days. If you have any questions regarding your warranty rights and responsibilities, you should contact:

Novus Performance Products LLC
customer service representative
1-800-409-7802
Email: Support@novuspowerequipment.com

DEFECTS WARRANTY REQUIREMENTS

(a) Applicability. This section applies to emissions control systems on small off-road engines or equipment that use small off- road engines subject to the emission standards in this Article. The warranty period begins on the date the engine or equipment is delivered to an ultimate purchaser and extends for a period of two years.

(b) General Emissions Warranty Coverage. The engine or equipment must be warranted to the ultimate purchaser and any subsequent owner that the emissions control system when installed was:

- (1) Designed, built, and equipped so as to conform with all applicable regulations; and
- (2) Free from defects in materials and workmanship that causes the failure of a warranted part for a period of two years.

(c) The warranty on emissions-related parts will be interpreted as follows:

- (1) Any warranted part that is not scheduled for replacement as required maintenance in the written instructions required by subsection (e) must be warranted for the warranty period defined in subsection (b)(2). If any such part fail during the period of warranty coverage, it must be repaired or replaced by Novus or it's contracted warranty provider according to subsection (4) below. Any such part repaired or replaced under the warranty must be warranted for a time not less than the remaining warranty period.
- (2) Any warranted part that is scheduled only for regular inspection in the written instructions required by subsection (e) must be warranted for the warranty period defined in subsection (b)(2). A statement in such written instructions to the effect of "repair or replace as necessary" shall advise owners of the warranty coverage for emissions related parts. Replacement within the warranty period is covered by the warranty and will not reduce the period of warranty coverage. Any such part repaired or replaced under warranty must be warranted for a time not less than the remaining warranty period.
- (3) Any warranted part that is scheduled for replacement as required maintenance in the written instructions required by subsection (e) must be warranted for the period of time prior to the first scheduled replacement point for that part. If the part fails prior to the first scheduled replacement, the part must be repaired or replaced by Novus according to Subsection (4) below. Any such part repaired or replaced under warranty must be warranted for a

time not less than the remainder of the period prior to the first scheduled replacement point for the part.

- (4) Repair or replacement of any warranted part under the warranty provisions of this article must be performed at no charge to the owner at a warranty station.
- (5) Notwithstanding the provisions of subsection (4) above, warranty services or repairs must be provided at distribution centers that are franchised to service the subject small off-road engine/equipment.
- (6) The small off-road engine/equipment owner must not be charged for diagnostic labor that leads to the determination that a warranted part is in fact defective, provided that such diagnostic work is performed at a warranty station.
- (7) Throughout the emissions control system's warranty period set out in subsection (b)(2), Novus or it's contracted warranty provider must maintain a supply of warranted parts sufficient to meet the expected demand for such parts and must obtain additional parts if that supply is exhausted.
- (8) Manufacturer-approved replacement parts that do not increase the exhaust or emissions of the engine or emissions control system must be used in the performance of any warranty maintenance or repairs and must be provided without charge to the owner. Such use will not reduce the warranty obligations of Novus or it's contracted warranty provider.
- (9) The use of add-on or modified parts may be grounds for disallowing a warranty claim made in accordance with this Article. Novus or it's contracted warranty provider will not be liable under this Article to warrant failures of warranted parts caused by the use of an add-on or modified part.
- (10) Novus shall provide any documents that describe that it's warranty procedures or policies within five working days of request by the Executive Officer.
- (d) A list of all emissions warranty parts must be included with each new engine or equipment subject to this Article. The emissions warranty parts list shall include all parts whose failure would increase exhaust and evaporative emissions, and contains the following parts:

EMISSIONS PARTS LIST

Exhaust Emission

- (1) Fuel Metering System
- (A) Carburetor and internal parts (and/or pressure regulator or fuel injection system).

- (B) Air/fuel ratio feedback and control system.
- (C) Cold start enrichment system.
- (2) Air Induction System
- (A) Controlled hot air intake system.
- (B) Intake manifold.
- (C) Air filter.
- (3) Ignition System
- (A) Spark Plugs.
- (B) Magneto or electronic ignition system.
- (C) Spark advance/retard system.
- (4) Exhaust Gas Recirculation (EGR) System
- (A) EGR valve body, and carburetor spacer if applicable.
- (B) EGR rate feedback and control system.
- (5) Air injection System
- (A) Air pump or pulse valve.
- (B) Valves affecting distribution of flow.
- (C) Distribution manifold.
- (6) Catalyst or Thermal Reactor System
- (A) Catalytic converter.
- (B) Thermal reactor.
- (C) Exhaust manifold.
- (7) Particulate Controls
- (A) Traps, filters, precipitators, and any other device used to capture particulate emissions.
- (B) Miscellaneous items Used in Above Systems
- (A) Vacuum, temperature, and time sensitive valves and switches.
- (B) Electronic controls.
- (C) Hoses, belts, connectors, and assemblies.

Evaporative Emission

- (1) Fuel Tank
- (2) Fuel Cap
- (3) Fuel lines(for liquid fuel and fuel vapors)
- (4) Fuel Line Fittings
- (5) Clamps
- (6) Pressure Relief Valves
- (7) Control Valves
- (8) Control Solenoids
- (9) Electronic Controls

- (10) Vacuum Control Diaphragms
- (11) Control Cables
- (12) Control Linkages
- (13) Purge Valves
- (14) Gaskets
- (15) Liquid/Vapor Separator
- (16) Carbon Canister
- (17) Canister Mounting Brackets
- (18) Carburetor Purge Port Connector

Note: As they relate to the emissions control system.

(e)Written instructions for the maintenance and use of the emissions control system by the owner shall be furnished with each new engine or equipment subject to this Article. The instructions must be consistent with this Article and applicable regulations contained herein.

(f)The documents required by subsections (d) and (e) must be submitted with the application for emissions control system certification for approval by the Executive Officer. Approval by the Executive Officer of the documents required by subsections (d) and (e) is a condition of certification. The Executive Officer will approve or disapprove the documents required by subsections (d) and (e) within 90 days of the date such documents are received.

(g)The application for emissions control system certification must also include a statement regarding the maintenance of the emissions control system. The statement must include, but not be limited to, information on emissions control system maintenance, and a maintenance schedule.

(h)Any other warranty statements applicable to engines or equipment units must not imply a limitation on the emissions warranty period or its applicability to subsequent owners after the ultimate purchaser. If the warranty period for any warranty other than the emissions warranty is less than two years, the statement of such warranty must specifically state that it does not limit the emissions warranty period of two years from purchase. If any warranty other than the emissions warranty does not extend to subsequent owners after the ultimate purchaser, the statement of such warranty must specifically state that it does not affect the applicability of the emissions warranty to subsequent owners after the ultimate purchaser.