



**MANUAL DE MONTAGEM
ASSEMBLY INSTRUCTIONS
INSTRUCCIONES DE MONTAJE**

**COD BR: BR 383 - 166
COD US: 159AMC6**

Sumário Summary Resumen

Introdução Introduction Introducción	3
Antes de começar Before starting Antes de comenzar	4
Evite acidentes Avoid accidents Evitar accidentes	4
Dimensões e ferramentas Dimensions and tools Dimensiones y herramientas	5
Identificação das peças Identifying parts Identificación de las piezas	6
Acessórios incluídos na caixa Hardware included in box Accesorios incluidos en la caja	7
Montagem do móvel Furniture assembly Montaje del mueble	8

Introdução Introduction Introducción

Leia atentamente este manual e siga os passos indicados para que o produto não perca a garantia e também para uma perfeita montagem.

Read this manual and follow the steps in order to keep the guarantee and also for the perfect fit.

Lea este manual y siga los pasos para que el producto no pierda la garantía y también para el ajuste perfecto.

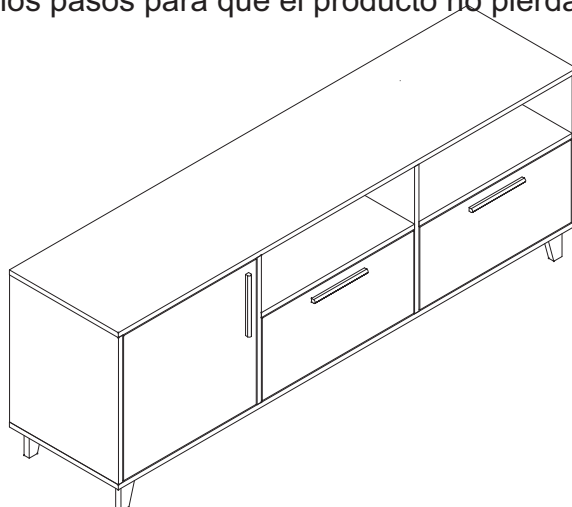

Antes de começar Before starting Antes de comenzar

Antes de começar a montagem prepare o ambiente, deixando-o completamente limpo e com bom espaço para iniciar o trabalho.

Prepare the room before starting the assembly, leaving it completely clean and the area in good condition to start the work.

Antes de comenzar el montaje preparar el ambiente, dejándolo completamente limpio y con bueno espacio para comenzar el trabajo.

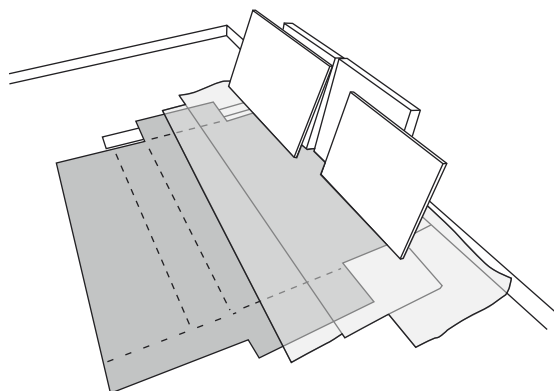

Utilize o papelão da própria embalagem para separar e apoiar as peças retiradas das caixas.

Use the cardboard of the packaging to separate and support the parts removed from the boxes.

Utilice el cartón de la embalaje para separar y apoyar las piezas desmontadas de las cajas.

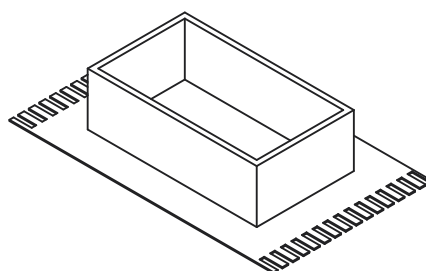

Forre a área de montagem com um cobertor ou tapete. Assim, você evita avarias nas peças durante o processo de montagem.

Cover the assembly area with a blanket or carpet to avoid damaging the parts during the assembly process.

Cubrir la zona de ensamble con una manta o alfombra. De este modo, se evitan daños en las piezas durante el proceso de montaje.



Evite acidentes Avoid accidents Prevenir accidentes

Solicitamos observar atentamente as orientações de montagem como: fixação do produto na parede, colocação de cola em locais específicos necessários, o peso suportado pelo produto, etc...

We request you to carefully observe the assembly instructions as: fixing the product on the wall, adding glue in needed and specific places, product weight limit, etc.

Pedimos que lea atentamente las instrucciones, principalmente las informaciones de fijación del producto en la pared, colocación de pegamento en local específico y necesario, el peso soportado por el producto etc...

Não escale ou se apoie no móvel.

Do not climb or lean on the furniture.

No se suba ni se apoye en el mueble.

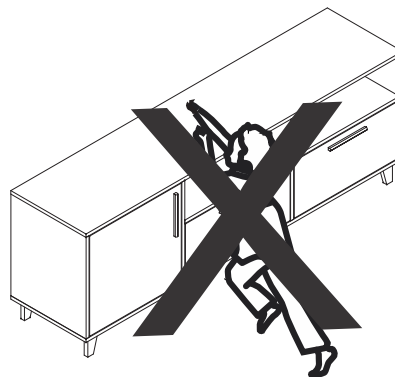

Dimensões e ferramentas
Dimensions and tools
Dimensiones y herramientas

Dimensões:

L: 1600 A: 565 P: 380 mm

Dimensions:

W: 62.99 H: 22.24 D: 14.96 inches

Dimensiones:

L: 1600 A: 565 P: 380 mm

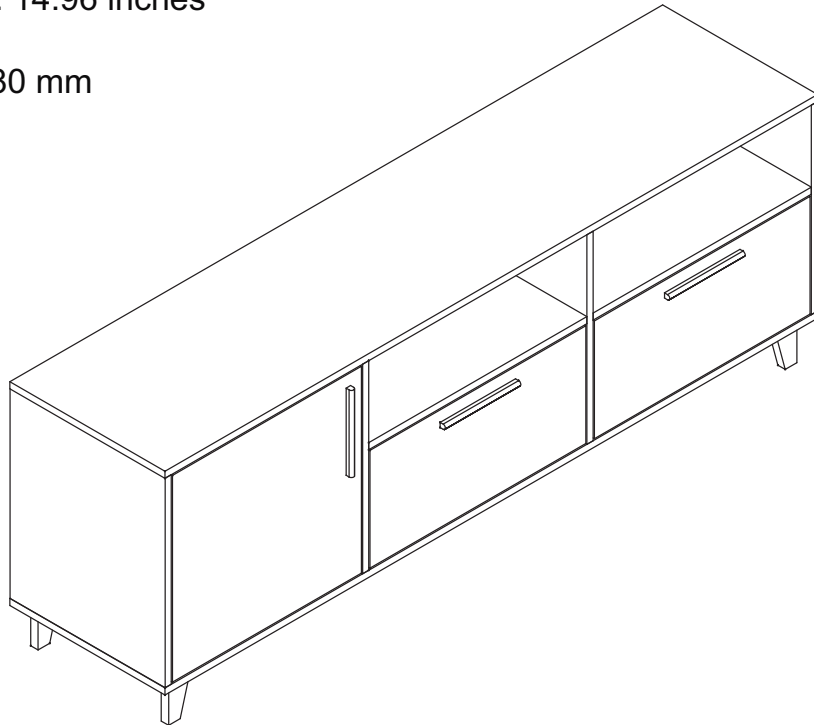

Limpeza
Cleanig
Limpieza

Pano levemente umedecido com água, seguido de pano seco, não utilizar produtos químico ou abrasivos.
Slightly dampened cloth and after a dry cloth, do not use chemicals or abrasives.
Solamente utilizar un paño húmedo y después un paño seco, no utilice productos químicos o abrasivos.

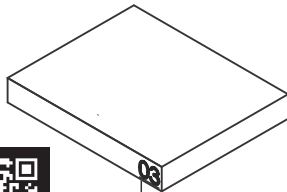

UTILIZE ALCOOL APENAS PARA REMOVER O NUMERO DAS PEÇAS
USE ALCOHOL ONLY TO REMOVE PART NUMBERS
UTILICE ALCOHOL SOLAMENTE PARA ELIMINAR EL NUMERO DE LAS PIEZAS

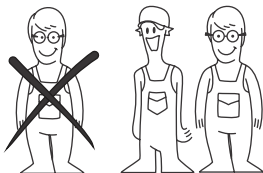

Para facilitar a montagem, utilize uma parafusadeira elétrica.
To improve assembly, use an eletronic screwdriver.
Para facilitar el armado, utilice un destornillador eléctrico.

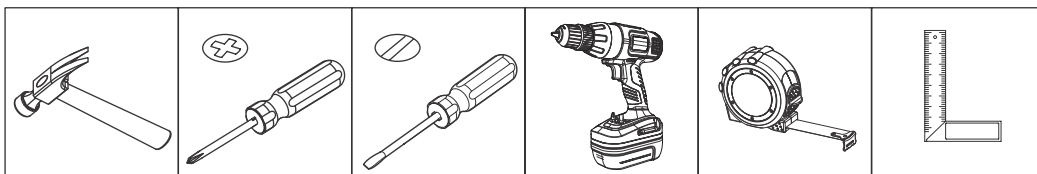

COD BR: BR 383 - 166
 COD US: 159AMC6

PEÇA	DESCRIÇÃO	QUANT.
001	BASE	1
002	TAMPO	1
003	LATERAL ESQUERDA	1
004	DIVISÓRIA ESQUERDA	1
005	DIVISÓRIA DIREITA	1
006	LATERAL DIREITA	1
007	PRATELEIRA	2
008	PORTA MAIOR	1
009	PORTA MENOR	2
010	COSTA MENOR	2
011	COSTA MAIOR	1
012	PÉS	4

PART	DESCRIPTION	QTY
001	BASE	1
002	TOP	1
003	LEFT SIDE	1
004	LEFT PARTITION	1
005	RIGHT PARTITION	1
006	RIGHT SIDE	1
007	SHELF	2
008	LONGER DOOR	1
009	LOWER DOOR	2
010	LOWER BACK	2
011	LONGER BACK	1
012	FEET	4

PIEZA	DESCRIPCIÓN	CANTIDAD
001	BASE	1
002	TAPA	1
003	LATERAL IZQUIERDA	1
004	PARTICIÓN IZQUIERDA	1
005	PARTICIÓN DERECHA	1
006	LATERAL DERECHA	1
007	REPISA	2
008	PUERTA MAYOR	1
009	PUERTA MENOR	2
010	REVÉS MENOR	2
011	REVÉS MAYOR	1
012	PIES	4

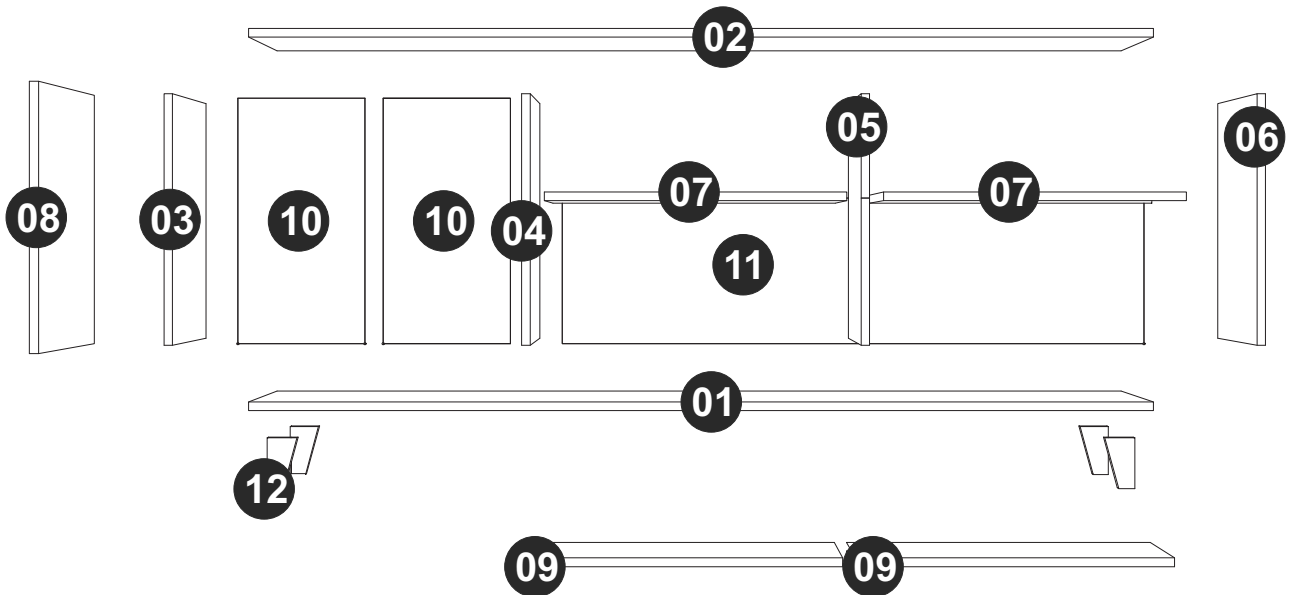



EF 000094 X 12



GIZ x 1
CHALK x 1
TIZA x 1



EF 000216 X 16



EF 000033 x 20

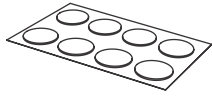

TAPA FUROS x 16
STICKER x 16
TAPAS PLÁSTICAS x 16

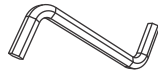

EF 000741 x 1

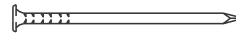

EF 000168 X 52

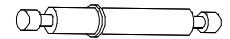

EF 000067 X 2

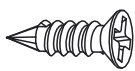

EF 000106 X 32



EF 000112 X 6



EF 000132 X 8



EF 000241 x 4



EF 000731 x 2

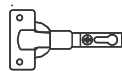

EF 000043 X 6



EF 000025 X 6



EF 000745 x 4



ARTICULADOR x 2
ARTICULATOR x 2
ARTICULADOR x 2

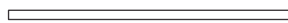

PERFIL PLÁSTICO x 1
PLASTIC PROFILE x 1
PERFIL PLASTICO x 1



= 18KG - 39.68LB



= 7KG - 15.43LB



= 6KG - 13.22LB

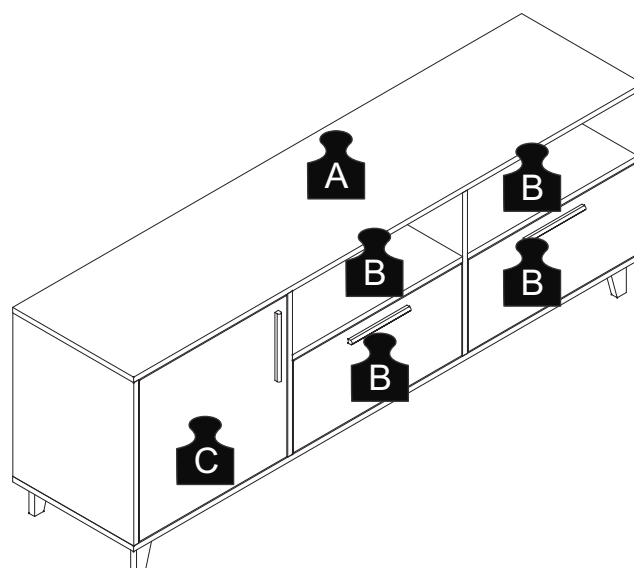

PASSO 1 / STEP 1 / PASO 1

Fixe a ferragem EF 000094 nas peças 02, 04 e 06.
Attach hardware EF 000094 into piece 02, 04 and 06.
Fije el herraje EF 000094 en la pieza 02, 04 y 06.

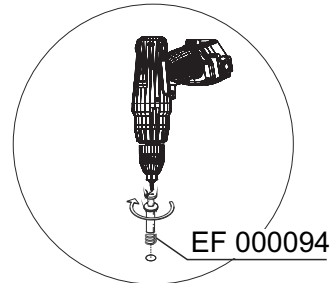
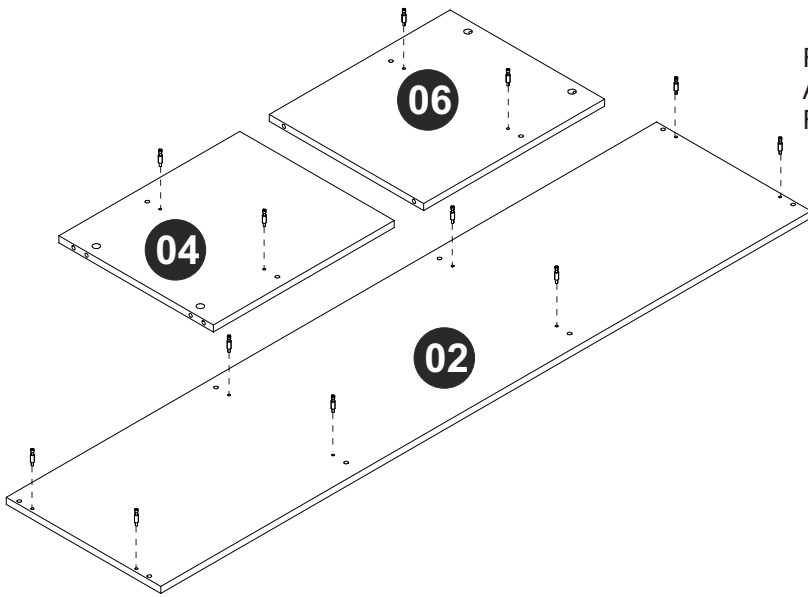

PASSO 2 / STEP 2 / PASO 2

Insira a ferragem EF 000033 nas peças 03, 04, 05, 06 e 07.
Insert hardware EF 000033 into pieces 03, 04, 05, 06 and 07.
Añade el herraje EF 000033 en las piezas 03, 04, 05, 06 y 07.

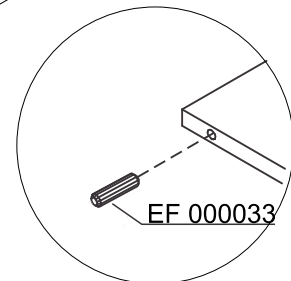
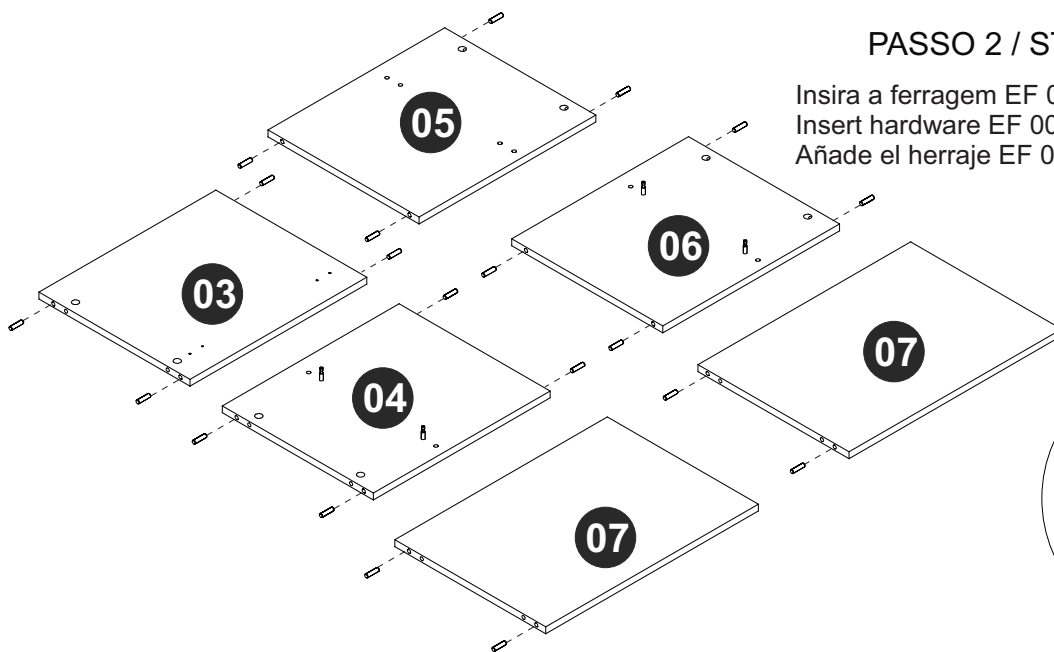

PASSO 3 / STEP 3 / PASO 3

Fixe a ferragem EF 000025 nas peças 02 e 03 utilizando a ferragem EF 000106.
Attach hardware EF 000025 on pieces 02 and 03 using hardware EF 000106.
Fije el herraje EF 000025 en las piezas 02 y 03 utilizando el herraje EF 000106.

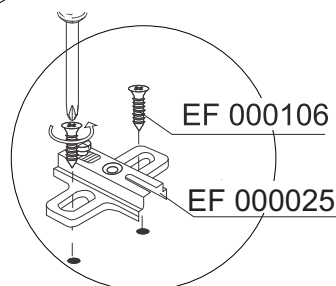
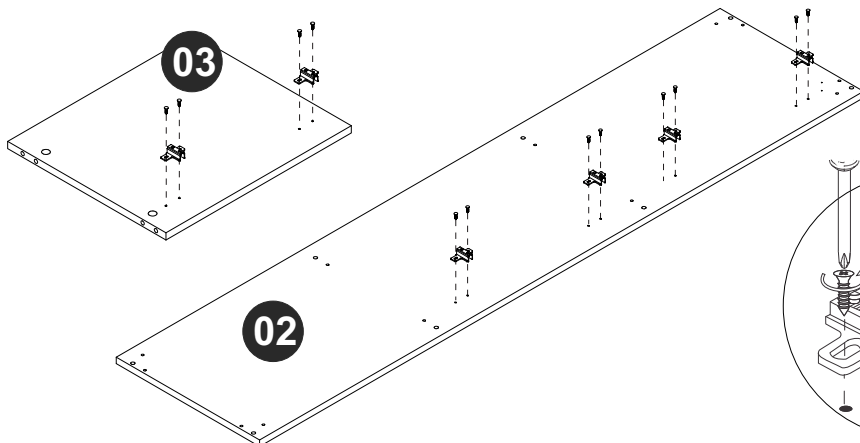

PASSO 4 / STEP 4 / PASO 4

Fixe a ferragem EF 000043 nas peças 08 e 09 utilizando a ferragem EF 000106.
Fixe o puxador utilizando a ferragem EF 000112.
Attach hardware EF 000043 on pieces 08 and 09 using hardware EF 000106.
Attach the handle using hardware EF 000112.
Fije el herraje EF 000043 a las piezas 08 y 09 utilizando el herraje EF 000106.
Fije la manija utilizando el herraje EF 000112.

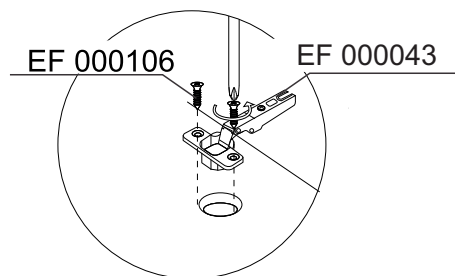
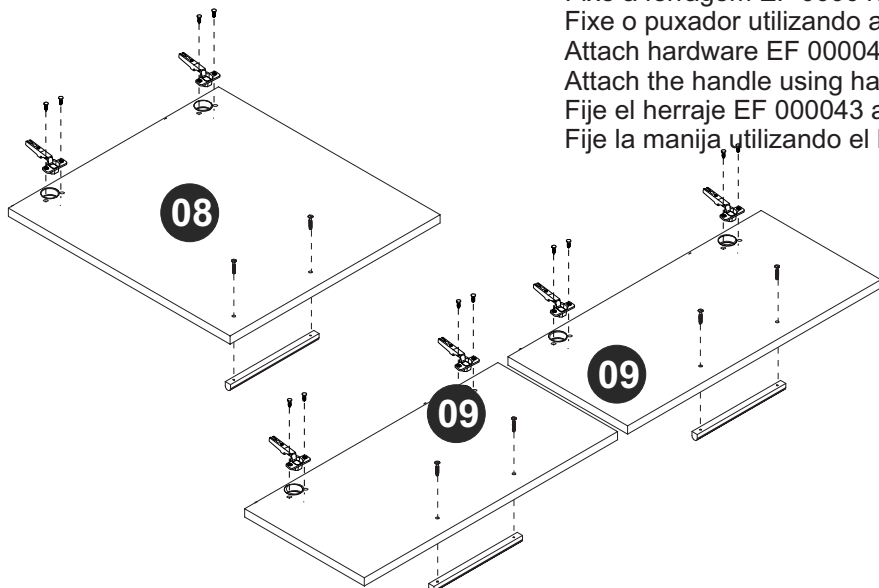

PASSO 5 / STEP 5 / PASO 5

De acordo com as medidas indicadas, fixe o articulador às peças 04 e 05 utilizando a ferragem EF 000106. Insira o suporte plástico.
According indicated measures, attach the articulator at pieces 04 and 05 using hardware EF 000106. Insert the plastic support.
De acuerdo con las medidas indicadas, fije los articuladores a las piezas 04 y 05 utilizando el herraje EF 000106. Añade el soporte plástico.

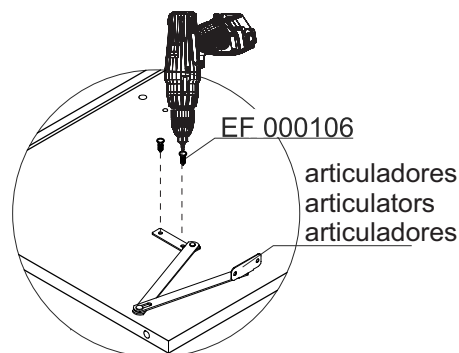
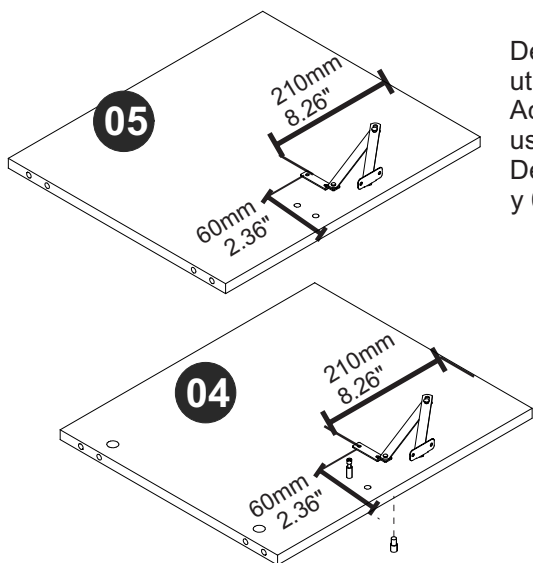

PASSO 6 / STEP 6 / PASO 6

Insira a ferragem EF 000241 nas peças 12.
Insert hardware EF 000241 in pieces 12.
Añade el herraje EF 000241 en las piezas 12.

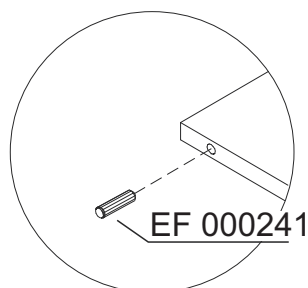
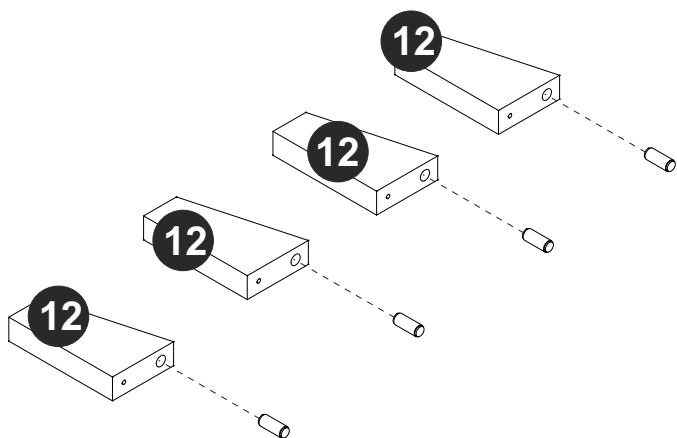

PASSO 7 / STEP 7 / PASO 7

Insira as ferragens EF 00067 e EF 000731 na peça 05, conecte as peças 07, insira a ferragem EF 000216 e gire para apertar.
Insert hardware EF 00067 and EF 000731 into piece 05, connect pieces 07, insert hardware EF 000216 and turn to tighten.
Añade los herrajes EF 00067 y EF 000731 en la pieza 05, junte las piezas 07, añada el herraje EF 000216 y gire para apretar.

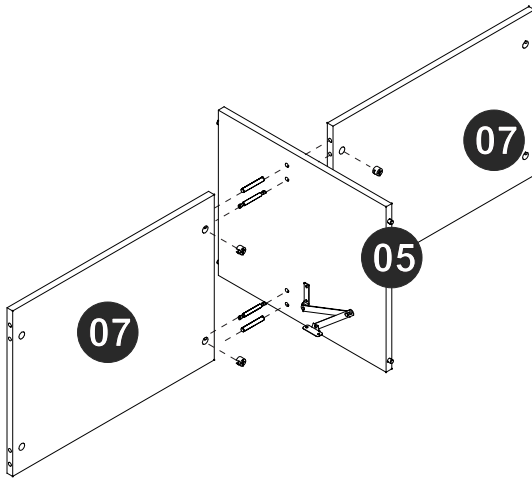

EF 000731
EF 00067
EF 000216

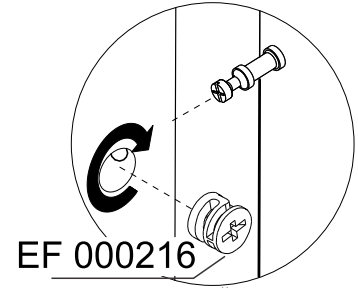
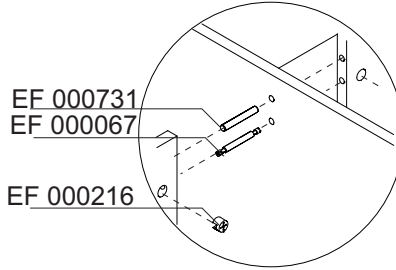

PASSO 8 / STEP 8 / PASO 8

Conecte as peças 04 e 06 à parte montada no passo anterior, insira a ferragem EF 000216 e gire para apertar.
Connect pieces 04 and 06 to the part assembled in the previous step, insert hardware EF 000216 and turn to tighten.
Junte las piezas 04 y 06 a la parte armada en el paso anterior, añada el herraje EF 000216 y gire para apretar.

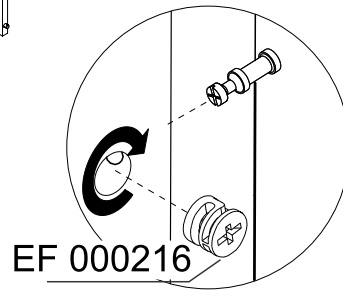
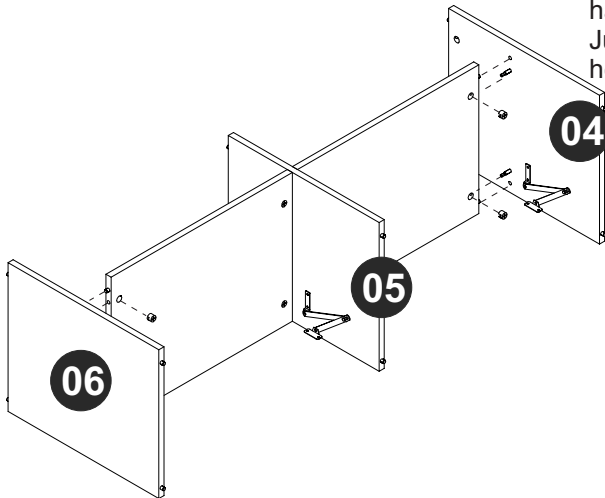

PASSO 9 / STEP 9 / PASO 9

Conecte a peça 02 e 03 à parte montada no passo anterior, insira a ferragem EF 000216 e gire para apertar.
Connect piece 02 and 03 to the part assembled in the previous step, insert hardware EF 000216 and turn to tighten.
Junte la pieza 02 y 03 a la parte armada en el paso anterior, añada el herraje EF 000216 y gire para apretar.

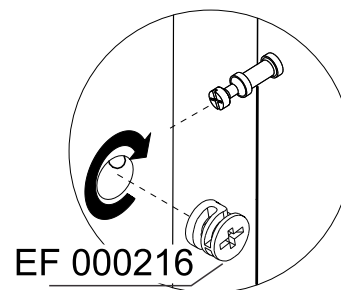
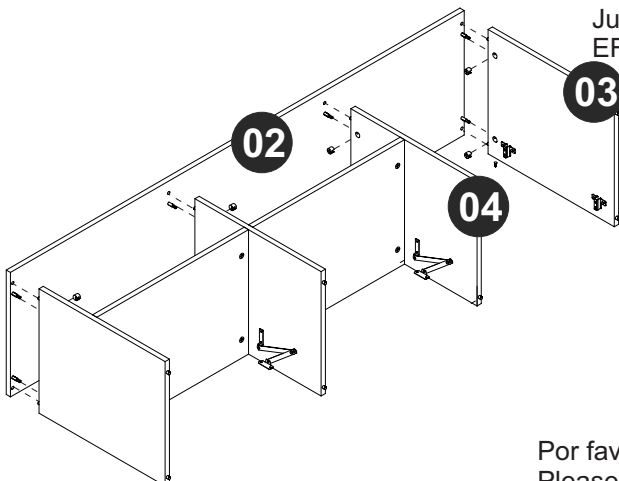

EF 000025

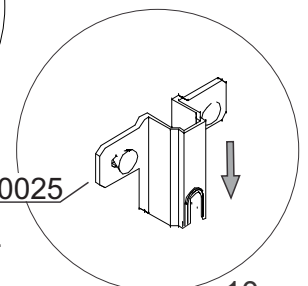

Por favor, observe a posição da ferragem EF 000025.
Please, note hardware EF 000025 position.
Por favor, observe la posición del herraje EF 000025.

PASSO 10 / STEP 10 / PASO 10

Fixe as peças 12 à peça 01 utilizando a ferragem EF 000745 e EF 000741.
Fix pieces 12 to piece 01 using hardware EF 000745 and EF 000741.
Junte las piezas 12 a la pieza 01 utilizando los herrajes EF 000745 y EF 000741.

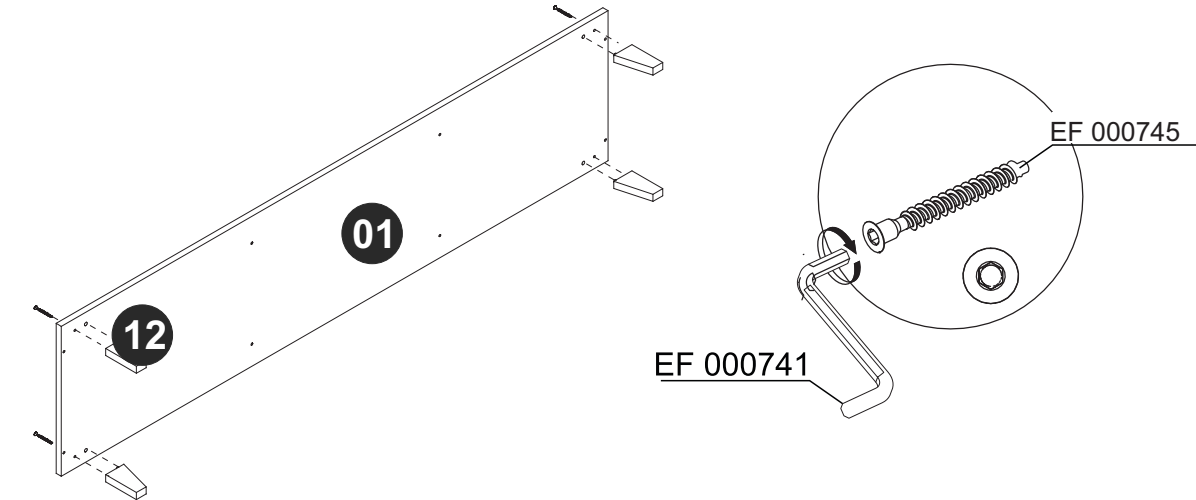

PASSO 11 / STEP 11/ PASO 11

Conecte a peça 01 à parte montada no passo anterior utilizando a ferragem EF 000132.
Connect piece 01 to the part assembled in the previous step using hardware EF 000132.
Junte la pieza 01 a la parte armada en el paso anterior utilizando el herraje EF 000132.

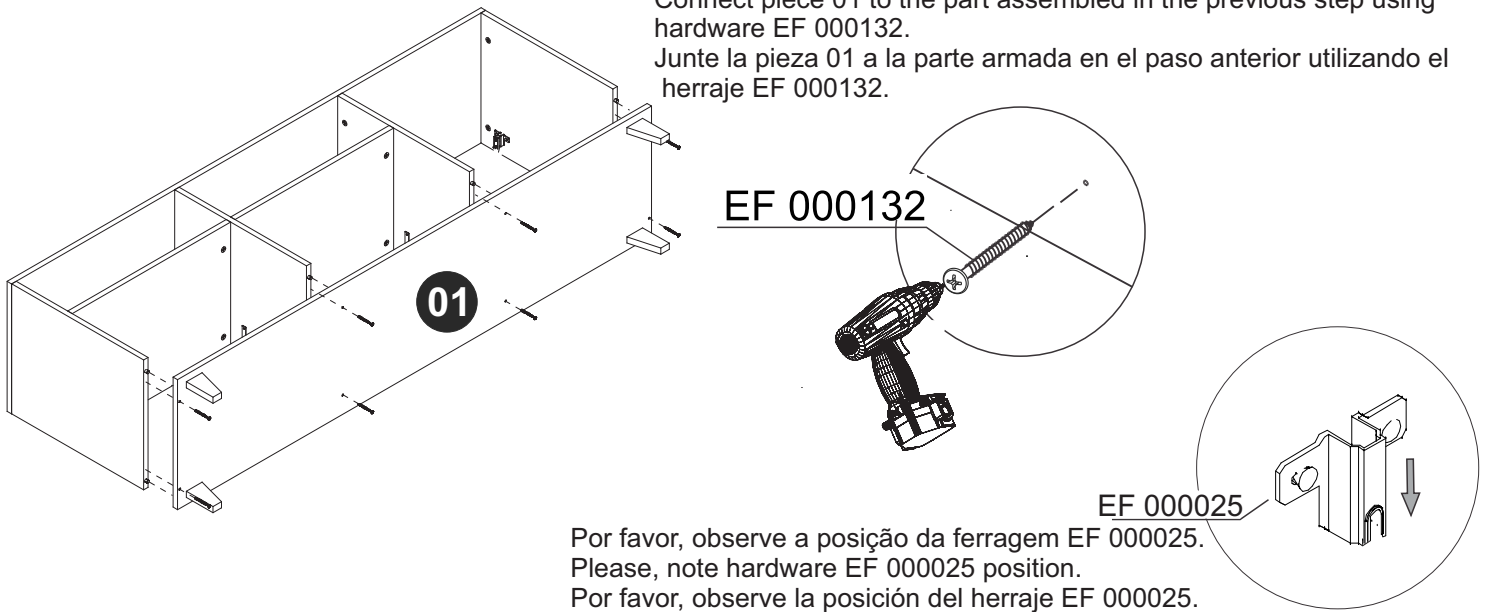

PASSO 12 / STEP 12 / PASO 12

Use o perfil plástico para unir as peças 10, fixe as peças 10 e 11 utilizando a ferragem EF 000168.
Use the plastic profile to fit pieces 10, attach pieces 10 and 11 using hardware EF 000168.
Utilice el perfil plastico para juntar las piezas 10, fije las piezas 10 y 11 utilizando el herraje EF 000168.

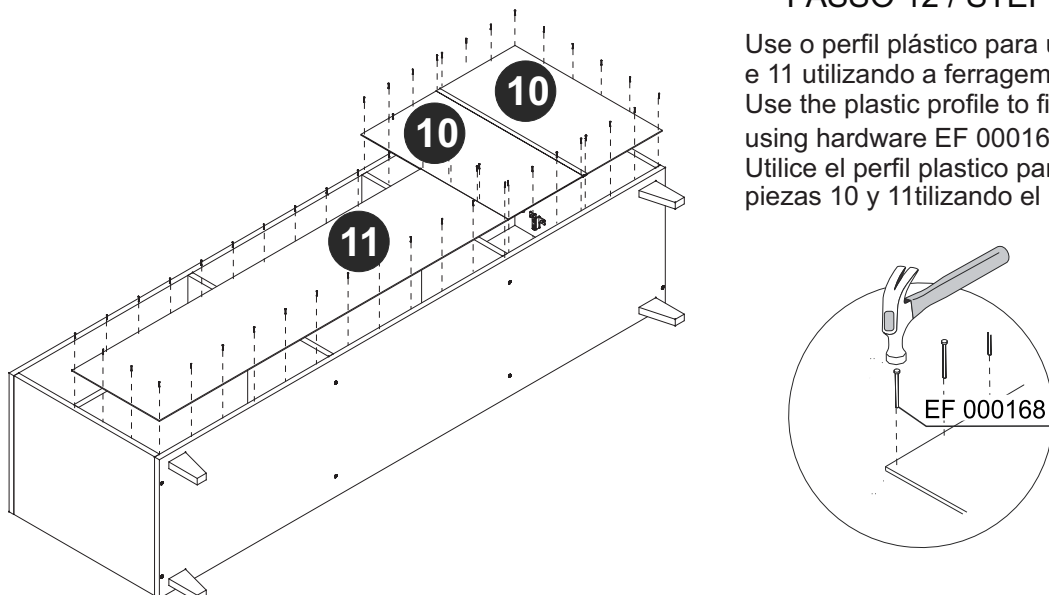

PASSO 13 / STEP 13/ PASO 13

Fixe as peças 08 e 09 ao móvel montado, fixe os articuladores à peça 09 utilizando a ferragem EF 000106.
Attach pieces 08 and 09 to assembled furniture, fix the articulators at piece 09 using hardware EF 000106.
Fije las piezas 08 y 09 al mueble armado, fije los articuladores en la pieza 09 utilizando el herraje EF 000106.

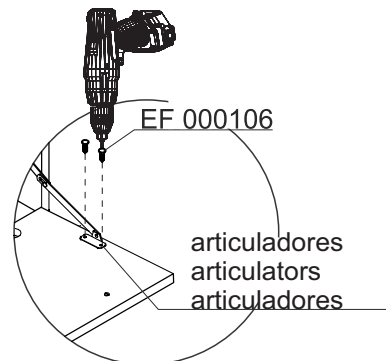
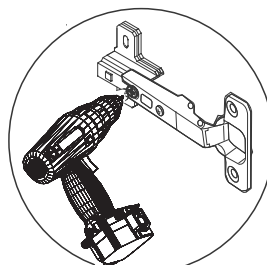
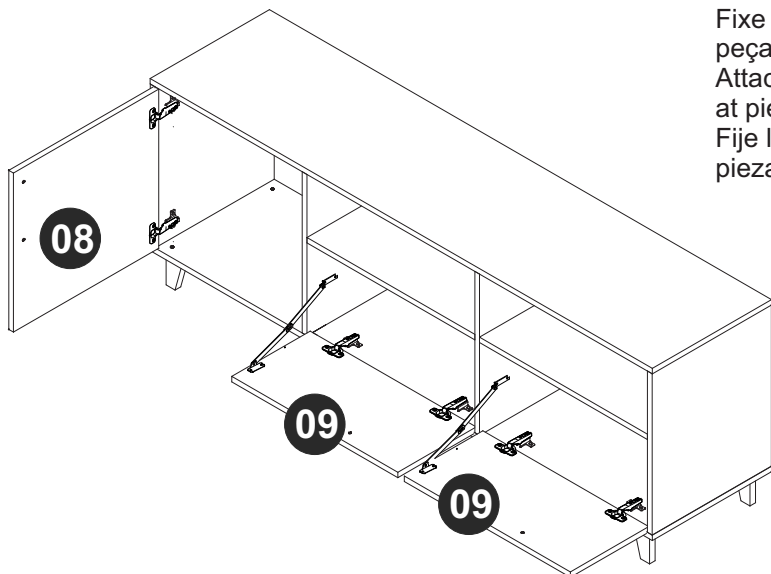

PASSO 14 / STEP 14 / PASO 14

Use os tapa furos para cobrir os parafusos aparentes.
Use o giz para dar o acabamento final ao produto.
Use stickers to cover apparent screws.
Use the chalk to give the final finish on the product.
Utilice los tapa huecos para cubrir los tornillos aparentes.
Utilice la tiza para dar el acabado final al producto.

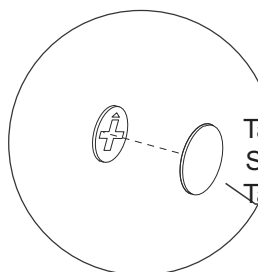
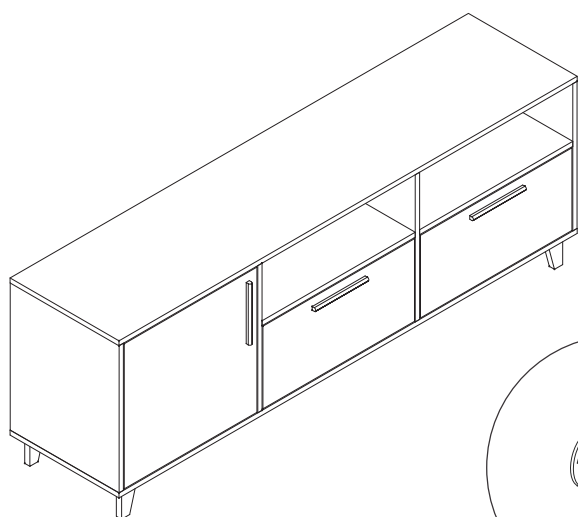

Tapa furos
Sticker
Tapas Plasticas

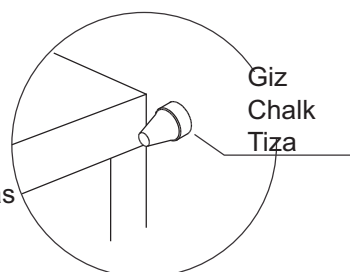

Giz
Chalk
Tiza

