

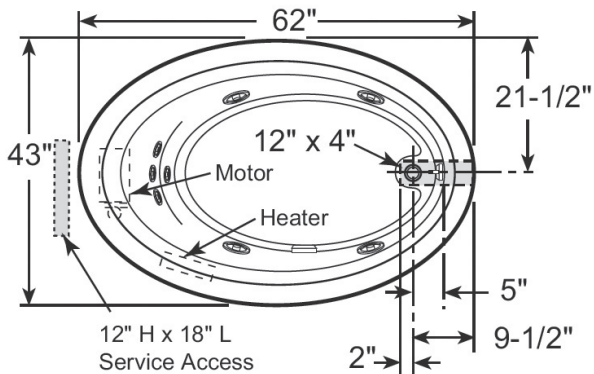

# Riva® 5 Whirlpool Plus Bath

- ES30** Riva 5 Whirlpool Bath, Left Hand
- ES40** Riva 5 Whirlpool Bath, Right Hand

- Left and Right Hand Drain Location
- Accessories / Hardware:
  - Rotary Drain Kit, 26" Cable #8730
  - Trip-Lever Drain Kit: #X559
  - Trim Kit: AccuPro Jet Rings #GU45
  - Trim Kit: TheraPro Jet Rings #GU44
- Trim Kit Finishes Available:
  - (827) - Chrome
  - (826) - Brushed Nickel
  - (849) - Oil Rubbed Bronze



**Product Shown: Riva® 5 Plus Whirlpool Bath Right Hand Shown Model: ES40**

\* Measurements inside unit represent cutout in floor to allow for drain/overflow. Minimum Service Access dimensions given.

## INSTALLATION NOTES

Refer to installation instructions included with fixture before beginning installation. Please confirm product availability and specifications before commencing with any installation work.

PRODUCT SPECIFICATIONS AND AVAILABILITY ARE SUBJECT TO CHANGE WITHOUT NOTICE.

## Technical Specifications

### DIMENSIONS

62" L x 43" W x 19" H  
(1575 mm) L x (1092 mm) W x (483 mm) H

### DRAIN/OVERFLOW

A: 14-3/4" (375 mm) B: 9-1/2" (241 mm)

### CUTOUT

Template Provided Part Number: GM28000

### TOTAL WEIGHT

779 lb (354 kg) / 44.2 lb/sq. ft. (215 kg/m<sup>2</sup>)

### OPERATING GALLONAGE

Min. 42 U.S. Gal. (151 Liters)  
Max. 54 U.S. Gal. (220 Liters)

### PRODUCT WEIGHT

96 lb (44 kg)

### SKIRT MOUNTING

Not Available

### ELECTRICAL SPECIFICATIONS

**Requires a dedicated GFCI protected separate circuit.**

Motor/Pump: 120 VAC, 15 AMP, 60 Hz.

RapidHeat™: 120 VAC, 15 AMP, 60 Hz.

### HEATER (OPTIONAL)

**Requires a dedicated GFCI protected separate circuit.**

RapidHeat™: P/N S750000



SIDE VIEW

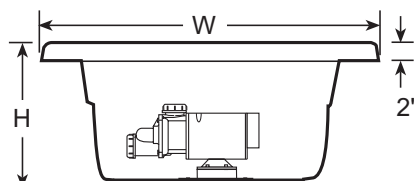

END VIEW

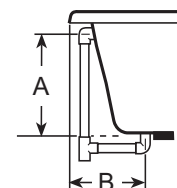

DRAIN/OVERFLOW